

MA3J700

Silicon epitaxial planar type

For high-frequency rectification

■ Features

- S-mini type 3-pin package
- Allowing to rectify under ($I_{F(AV)} = 500 \text{ mA}$) condition
- Optimum for high-frequency rectification because of its short reverse recovery time (t_{rr})

■ Absolute Maximum Ratings $T_a = 25^\circ\text{C}$

Parameter	Symbol	Rating	Unit
Reverse voltage (DC)	V_R	40	V
Repetitive peak reverse voltage	V_{RRM}	40	V
Average forward current	$I_{F(AV)}$	500	mA
Non-repetitive peak forward surge current*	I_{FSM}	2	A
Junction temperature	T_j	125	$^\circ\text{C}$
Storage temperature	T_{stg}	-55 to +150	$^\circ\text{C}$

Note) * : The peak-to-peak value in one cycle of 50 Hz sine-wave (non-repetitive)

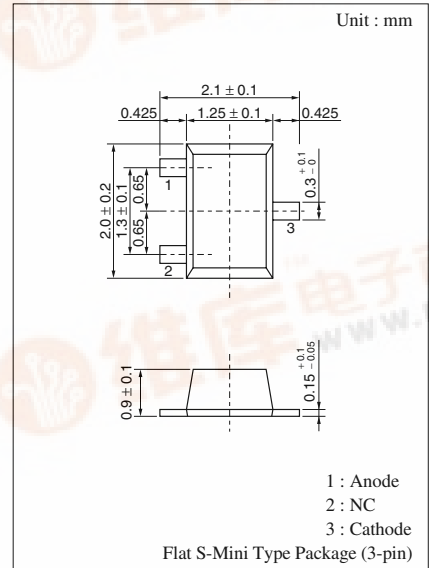

Marking Symbol: M2W

Internal Connection

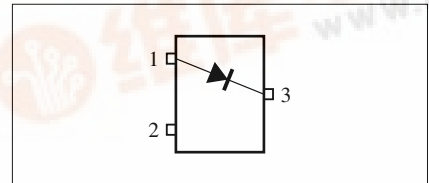

■ Electrical Characteristics $T_a = 25^\circ\text{C}$

Parameter	Symbol	Conditions	Min	Typ	Max	Unit
Reverse current (DC)	I_R	$V_R = 35 \text{ V}$			100	μA
Forward voltage (DC)	V_F	$I_F = 500 \text{ mA}$			0.55	V
Terminal capacitance	C_t	$V_R = 0 \text{ V}, f = 1 \text{ MHz}$		60		pF
Reverse recovery time*	t_{rr}	$I_F = I_R = 100 \text{ mA}$ $I_{TR} = 0.1 \cdot I_R, R_L = 100 \Omega$		5		ns

- Note) 1. Schottky barrier diode is sensitive to electric shock (static electricity, etc.). Due attention must be paid on the charge of a human body and the leakage of current from the operating equipment.
 2. Rated input/output frequency: 400 MHz
 3. * : t_{rr} measuring circuit

