

# MA3Z080D, MA3Z080E

Silicon epitaxial planar type

For band switching

## ■ Features

- Low forward dynamic resistance  $r_f$
- Less voltage dependence of diode capacitance  $C_D$
- S-mini type package containing two elements, allowing downsizing of equipment and automatic insertion through the taping package

## ■ Absolute Maximum Ratings $T_a = 25^\circ\text{C}$

Parameter	Symbol	Rating	Unit
Reverse voltage (DC)	$V_R$	35	V
Forward current (DC)	$I_F$	100	mA
Operating ambient temperature*	$T_{opr}$	-25 to +85	$^\circ\text{C}$
Storage temperature	$T_{stg}$	-55 to +150	$^\circ\text{C}$

Note) \* : Maximum ambient temperature during operation

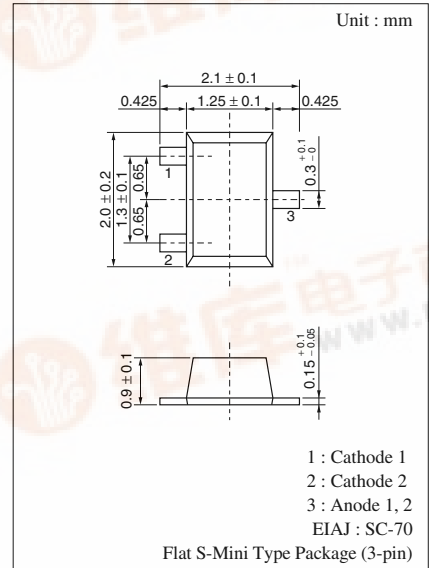

## Marking Symbol

- MA3Z080D : M1X
- MA3Z080E : M1Y

## Internal Connection

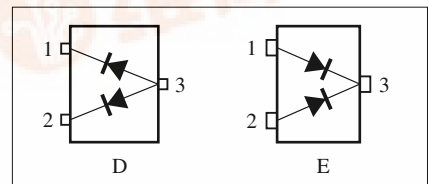

## ■ Electrical Characteristics $T_a = 25^\circ\text{C}$

Parameter	Symbol	Conditions	Min	Typ	Max	Unit
Reverse current (DC)	$I_R$	$V_R = 33\text{ V}$		0.01	100	nA
Forward voltage (DC)	$V_F$	$I_F = 100\text{ mA}$		0.92	1.0	V
Diode capacitance	$C_D$	$V_R = 6\text{ V}, f = 1\text{ MHz}$		0.9	1.2	pF
Forward dynamic resistance*	$r_f$	$I_F = 2\text{ mA}, f = 100\text{ MHz}$		0.65	0.85	$\Omega$

Note) 1. Each characteristic is a standard for individual diodes

2. Rated input/output frequency: 100 MHz

3. \*:  $r_f$  measuring instrument: YHP MODEL 4191A RF IMPEDANCE ANALYZER

