



# Quad, Low-Power, Current-Feedback OPERATIONAL AMPLIFIER

## FEATURES

- MINIMAL BANDWIDTH CHANGE VERSUS GAIN
- 170MHz BANDWIDTH AT  $G = +2$
- > 120MHz BANDWIDTH TO GAIN > +10
- LOW DISTORTION: < -78dBc at 5MHz
- HIGH OUTPUT CURRENT: 120mA
- SINGLE +5V TO +12V SUPPLY OPERATION
- DUAL  $\pm 2.5$  TO  $\pm 6.0$ V SUPPLY OPERATION
- LOW SUPPLY CURRENT: 6.8mA Total

## DESCRIPTION

The OPA4684 provides a new level of performance in low-power, wideband, current-feedback (CFB) amplifiers. This CFB<sub>PLUS</sub> amplifier is among the first to use an internally closed-loop input buffer stage that enhances performance significantly over earlier low-power CFB amplifiers. While retaining the benefits of very low power operation, this new architecture provides many of the benefits of a more ideal CFB amplifier. The closed-loop input stage buffer gives a very low and linearized impedance path at the inverting input to sense the feedback error current. This improved inverting input impedance retains exceptional bandwidth to much higher gains and improves harmonic distortion over earlier solutions limited by inverting input linearity. Beyond simple high-gain applications, the OPA4684 CFB<sub>PLUS</sub> amplifier permits the gain setting element to be set with considerable

## APPLICATIONS

- LOW-POWER BROADCAST VIDEO DRIVERS
- EQUALIZING FILTERS
- SAW FILTER HIGH-GAIN POST AMPLIFIERS
- MULTICHANNEL SUMMING AMPLIFIERS
- WIDEBAND DIFFERENTIAL CHANNELS
- ANALOG-TO-DIGITAL CONVERTERS (ADC) INPUT DRIVERS
- MULTIPLE POLE ACTIVE FILTERS
- OPA4658 LOW-POWER UPGRADE

freedom from amplifier bandwidth interaction. This allows frequency response peaking elements to be added, multiple input inverting summing circuits to have greater bandwidth, and low-power line drivers to meet the demanding requirements of studio cameras and broadcast video.

The output capability of the OPA4684 also sets a new mark in performance for low-power current-feedback amplifiers. Delivering a full  $\pm 4$ Vp-p swing on  $\pm 5$ V supplies, the OPA4684 also has the output current to support  $> \pm 3$ V swing into  $50\Omega$ . This minimal output headroom requirement is complemented by a similar 1.2V input stage headroom giving exceptional capability for single +5V operation.

The OPA4684's low 6.8mA supply current is precisely trimmed at 25°C. This trim, along with low shift over temperature and supply voltage, gives a very robust design over a wide range of operating conditions.

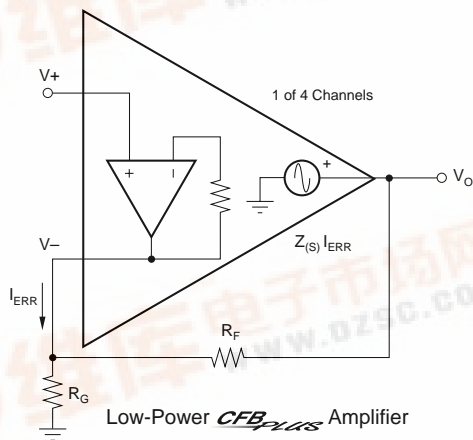

Patent Pending

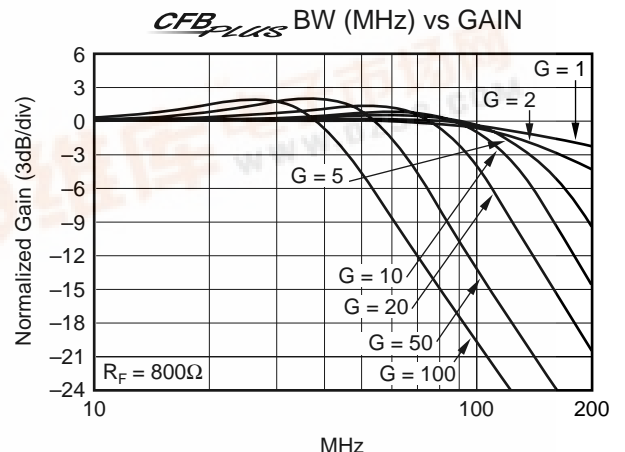

Please be aware that an important notice concerning availability, standard warranty, and use in critical applications of Texas Instruments semiconductor products and disclaimers thereto appears at the end of this data sheet.

## ABSOLUTE MAXIMUM RATINGS<sup>(1)</sup>

Power Supply .....	$\pm 6.5V_{DC}$
Internal Power Dissipation .....	See Thermal Information
Differential Input Voltage .....	$\pm 1.2V$
Input Voltage Range .....	$\pm V_S$
Storage Temperature Range: ID, IDBV .....	$-40^{\circ}C$ to $+125^{\circ}C$
Lead Temperature (soldering, 10s) .....	$+300^{\circ}C$
Junction Temperature ( $T_J$ ) .....	$+175^{\circ}C$
ESD Rating: HBM .....	2000V
CDM .....	1500V

NOTE: (1) Stresses above these ratings may cause permanent damage. Exposure to absolute maximum conditions for extended periods may degrade device reliability.



## ELECTROSTATIC DISCHARGE SENSITIVITY

This integrated circuit can be damaged by ESD. Texas Instruments recommends that all integrated circuits be handled with appropriate precautions. Failure to observe proper handling and installation procedures can cause damage.

ESD damage can range from subtle performance degradation to complete device failure. Precision integrated circuits may be more susceptible to damage because very small parametric changes could cause the device not to meet its published specifications.

## OPA4684 RELATED PRODUCTS

SINGLES	DUALS	TRIPLES	FEATURES
OPA683	OPA2683	—	Very Low-Power CFB <sub>PLUS</sub>
OPA684	OPA2684	OPA3684	Low-Power CFB <sub>PLUS</sub>
OPA691	OPA2691	OPA3691	High Slew Rate CFB
OPA685	—	—	> 500MHz CFB

## PACKAGE/ORDERING INFORMATION

PRODUCT	PACKAGE-LEAD	PACKAGE DESIGNATOR <sup>(1)</sup>	SPECIFIED TEMPERATURE RANGE	PACKAGE MARKING	ORDERING NUMBER	TRANSPORT MEDIA, QUANTITY
OPA4684	SO-14	D	$-40^{\circ}C$ to $+85^{\circ}C$	OPA4684	OPA4684ID	Rails, 58
"	"	"	"	"	OPA4684IDR	Tape and Reel, 2500
OPA4684	TSSOP-14	PW	$-40^{\circ}C$ to $+85^{\circ}C$	OPA4684	OPA4684IPWT	Tape and Reel, 250
"	"	"	"	"	OPA4684IPWR	Tape and Reel, 2500

NOTE: (1) For the most current specifications, and package information, refer to our web site at [www.ti.com](http://www.ti.com).

## PIN CONFIGURATION

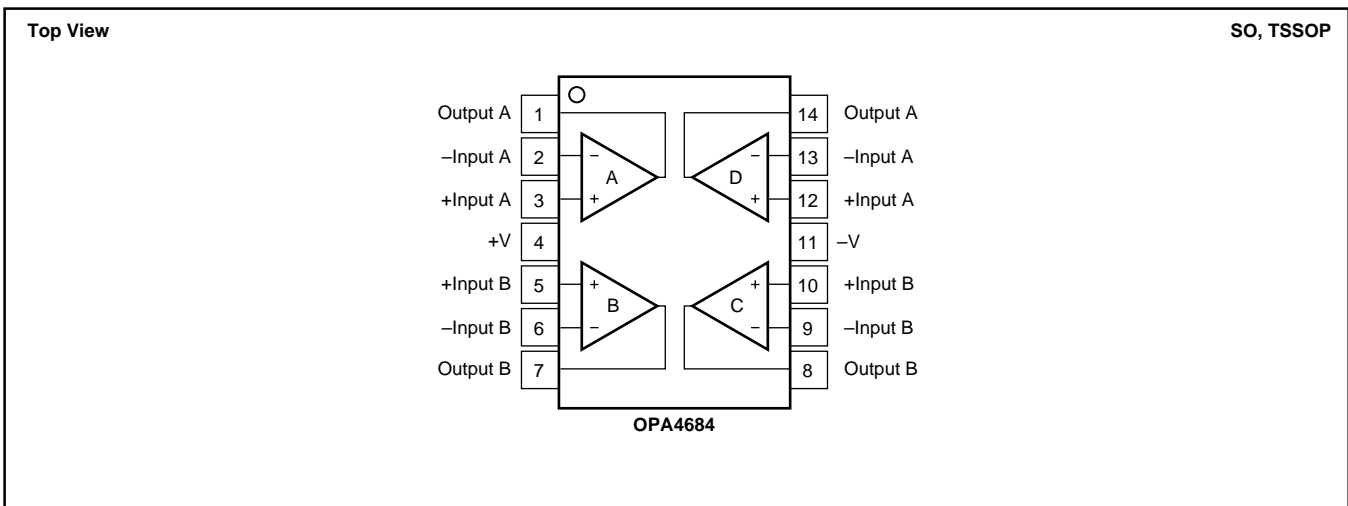

# ELECTRICAL CHARACTERISTICS: $V_S = \pm 5V$

**Boldface** limits are tested at **+25°C**.

$R_F = 800\Omega$ ,  $R_L = 100\Omega$ , and  $G = +2$ , (see Figure 1 for AC performance only), unless otherwise noted.

PARAMETER	CONDITIONS	OPA4684ID, IPW						TEST LEVEL <sup>(3)</sup>
		TYP	MIN/MAX OVER TEMPERATURE				MIN/MAX	
		+25°C	+25°C <sup>(1)</sup>	0°C to 70°C <sup>(2)</sup>	-40°C to +85°C <sup>(2)</sup>	UNITS		
<b>AC PERFORMANCE (See Figure 1)</b>								
Small-Signal Bandwidth ( $V_O = 0.5V_{p-p}$ )	$G = +1, R_F = 800\Omega$	250				MHz	typ	C
	$G = +2, R_F = 800\Omega$	170	120	118	117	MHz	min	B
	$G = +5, R_F = 800\Omega$	138				MHz	typ	C
	$G = +10, R_F = 800\Omega$	120				MHz	typ	C
	$G = +20, R_F = 800\Omega$	95				MHz	typ	C
Bandwidth for 0.1dB Gain Flatness	$G = +2, V_O = 0.5V_{p-p}, R_F = 800\Omega$	19	16	14	14	MHz	min	B
Peaking at a Gain of +1	$R_F = 800\Omega, V_O = 0.5V_{p-p}$	1.4	4.8	5.9	6.3	dB	max	B
Large-Signal Bandwidth	$G = +2, V_O = 4V_{p-p}$	90				MHz	typ	C
Slew Rate	$G = -1, V_O = 4V$ Step	780	675	650	575	V/ $\mu$ s	min	B
	$G = +2, V_O = 4V$ Step	750	680	660	650	V/ $\mu$ s	min	B
Rise-and-Fall Time	$G = +2, V_O = 0.5V$ Step	3				ns	typ	C
	$G = +2, V_O = 4V$ Step	6.8				ns	typ	C
Harmonic Distortion								
2nd-Harmonic	$R_L = 100\Omega$	-67	-59	-59	-58	dBc	max	B
	$R_L \geq 1k\Omega$	-82	-66	-65	-65	dBc	max	B
3rd-Harmonic	$R_L = 100\Omega$	-70	-66	-65	-65	dBc	max	B
	$R_L \geq 1k\Omega$	-84	-82	-81	-81	dBc	max	B
Input Voltage Noise	$f > 1MHz$	3.7	4.1	4.2	4.4	nV/ $\sqrt{Hz}$	max	B
Noninverting Input Current Noise	$f > 1MHz$	9.4	11	12	12.5	pA/ $\sqrt{Hz}$	max	B
Inverting Input Current Noise	$f > 1MHz$	17	18	18.5	19	pA/ $\sqrt{Hz}$	max	B
Differential Gain	$G = +2, NTSC, V_O = 1.4V_{p-p}, R_L = 150\Omega$	0.04				%	typ	C
Differential Phase	$G = +2, NTSC, V_O = 1.4V_{p-p}, R_L = 150\Omega$	0.02				deg	typ	C
All Hostile Crosstalk, Input Referred	3 Channels Driven at 5MHz, 1Vp-p 4th Channel Measured	-52				dB	typ	C
<b>DC PERFORMANCE<sup>(4)</sup></b>								
Open-Loop Transimpedance Gain ( $Z_{OL}$ )	$V_O = 0V, R_L = 1k\Omega$	355	<b>160</b>	155	153	k $\Omega$	min	A
Input Offset Voltage	$V_{CM} = 0V$	$\pm 1.5$	<b><math>\pm 4.0</math></b>	$\pm 4.6$	$\pm 4.8$	mV	max	A
Average Offset Voltage Drift	$V_{CM} = 0V$			$\pm 12$	$\pm 12$	$\mu V/^\circ C$	max	B
Noninverting Input Bias Current	$V_{CM} = 0V$	$\pm 5.0$	<b><math>\pm 13</math></b>	$\pm 14.5$	$\pm 15$	$\mu A$	max	A
Average Noninverting Input Bias Current Drift	$V_{CM} = 0V$			$\pm 25$	$\pm 30$	nA/ $^\circ C$	max	B
Inverting Input Bias Current	$V_{CM} = 0V$	$\pm 5.0$	<b><math>\pm 17</math></b>	$\pm 18.5$	$\pm 19.5$	$\mu A$	max	A
Average Inverting Input Bias Current Drift	$V_{CM} = 0V$			$\pm 35$	$\pm 40$	nA/ $^\circ C$	max	B
<b>INPUT</b>								
Common-Mode Input Range <sup>(5)</sup> (CMIR)		$\pm 3.75$	<b><math>\pm 3.65</math></b>	$\pm 3.65$	$\pm 3.6$	V	min	A
Common-Mode Rejection Ratio (CMRR)	$V_{CM} = 0V$	60	<b>53</b>	52	52	dB	min	A
Noninverting Input Impedance		50    2				k $\Omega$    pF	typ	C
Inverting Input Resistance ( $R_I$ )	Open-Loop, DC	4.0				$\Omega$	typ	C
<b>OUTPUT</b>								
Voltage Output Swing	1k $\Omega$ Load	$\pm 4.1$	<b><math>\pm 3.9</math></b>	$\pm 3.9$	$\pm 3.8$	V	min	A
Current Output, Sourcing	$V_O = 0$	160	<b>120</b>	115	110	mA	min	A
Current Output, Sinking	$V_O = 0$	-120	<b>-100</b>	-95	-90	mA	min	A
Closed-Loop Output Impedance	$G = +2, f = 100kHz$	0.006				$\Omega$	typ	C
<b>POWER SUPPLY</b>								
Specified Operating Voltage		$\pm 5$				V	typ	C
Maximum Operating Voltage Range			<b><math>\pm 6</math></b>	$\pm 6$	$\pm 6$	V	max	A
Max Quiescent Current	$V_S = \pm 5V$	6.8	<b>7.2</b>	7.6	7.8	mA	max	A
Min Quiescent Current	$V_S = \pm 5V$	6.8	<b>6.4</b>	6.2	5.8	mA	min	A
Power-Supply Rejection Ratio (-PSRR)	Input Referred	60	<b>54</b>	53	53	dB	typ	A
<b>TEMPERATURE RANGE</b>								
Specification: ID, IPW		-40 to +85				$^\circ C$	typ	C
Thermal Resistance, $\theta_{JA}$	Junction-to-Ambient					$^\circ C/W$	typ	C
D SO-14		100				$^\circ C/W$	typ	C
PW TSSOP-14		110				$^\circ C/W$	typ	C

NOTES: (1) Junction temperature = ambient for 25°C tested specifications. (2) Junction temperature = ambient at low temperature limit, junction temperature = ambient +7°C at high temperature limit for over temperature tested specifications. (3) Test levels: (A) 100% tested at 25°C. Over temperature limits by characterization and simulation. (B) Limits set by characterization and simulation. (C) Typical value only for information. (4) Current is considered positive out-of-node.  $V_{CM}$  is the input common-mode voltage. (5) Tested < 3dB below minimum specified CMR at  $\pm$ CMIR limits.

# ELECTRICAL CHARACTERISTICS: $V_S = +5V$

**Boldface** limits are tested at **+25°C**.

$R_F = 1k\Omega$ ,  $R_L = 100\Omega$ , and  $G = +2$ , (see Figure 3 for AC performance only), unless otherwise noted.

PARAMETER	CONDITIONS	OPA4684ID, IPW					UNITS	MIN/ MAX	TEST LEVEL <sup>(3)</sup>
		TYP	MIN/MAX OVER TEMPERATURE						
		+25°C	+25°C <sup>(1)</sup>	0°C to 70°C <sup>(2)</sup>	-40°C to +85°C <sup>(2)</sup>				
<b>AC PERFORMANCE (See Figure 3)</b>									
Small-Signal Bandwidth ( $V_O = 0.5V_{p-p}$ )	$G = +1$ , $R_F = 1.3k\Omega$	140				MHz	typ	C	
	$G = +2$ , $R_F = 1.3k\Omega$	110	86	85	82	MHz	min	B	
	$G = +5$ , $R_F = 1.3k\Omega$	100				MHz	min	C	
	$G = +10$ , $R_F = 1.3k\Omega$	90				MHz	typ	C	
	$G = +20$ , $R_F = 1.3k\Omega$	75				MHz	typ	C	
Bandwidth for 0.1dB Gain Flatness	$G = +2$ , $V_O < 0.5V_{p-p}$ , $R_F = 1.3k\Omega$	21	12	11	10	MHz	min	B	
Peaking at a Gain of +1	$R_F = 1.3k\Omega$ , $V_O < 0.5V_{p-p}$	0.5	2.6	3.4	3.7	dB	max	B	
Large-Signal Bandwidth	$G = 2$ , $V_O = 2V_{p-p}$	86				MHz	typ	C	
Slew Rate	$G = 2$ , $V_O = 2V$ Step	300	300	290	280	V/ $\mu$ s	min	B	
	$G = 2$ , $V_O = 0.5V$ Step	4.3				ns	typ	C	
	$G = 2$ , $V_O = 2V$ Step	5.3				ns	typ	C	
Rise-and-Fall Time	$G = 2$ , $f = 5MHz$ , $V_O = 2V_{p-p}$								
Harmonic Distortion	$R_L = 100\Omega$ to $V_S/2$	-65	-60	-59	-59	dBc	max	B	
2nd-Harmonic	$R_L \geq 1k\Omega$ to $V_S/2$	-84	-62	-61	-61	dBc	max	B	
3rd-Harmonic	$R_L = 100\Omega$ to $V_S/2$	-65	-64	-63	-63	dBc	max	B	
	$R_L \geq 1k\Omega$ to $V_S/2$	-74	-70	-70	-69	dBc	max	B	
Input Voltage Noise	$f > 1MHz$	3.7	4.1	4.2	4.4	nV/ $\sqrt{Hz}$	max	B	
Noninverting Input Current Noise	$f > 1MHz$	9.4	11	12	12.5	pA/ $\sqrt{Hz}$	max	B	
Inverting Input Current Noise	$f > 1MHz$	17	18	18.5	19	pA/ $\sqrt{Hz}$	max	B	
Differential Gain	$G = +2$ , NTSC, $V_O = 1.4V_{p-p}$ , $R_L = 150\Omega$	0.04				%	typ	C	
Differential Phase	$G = +2$ , NTSC, $V_O = 1.4V_{p-p}$ , $R_L = 150\Omega$	0.07				deg	typ	C	
All Hostile X-Talk, Input Referred	3-Channels Driven at 5MHz, 1Vp-p 4th Channel Measured	-52				dB	typ	C	
<b>DC PERFORMANCE<sup>(4)</sup></b>									
Open-Loop Transimpedance Gain ( $Z_{OL}$ )	$V_O = V_S/2$ , $R_L = 1k\Omega$ to $V_S/2$	355	<b>160</b>	155	153	k $\Omega$	min	A	
Input Offset Voltage	$V_{CM} = V_S/2$	$\pm 1.0$	<b><math>\pm 3.5</math></b>	$\pm 4.1$	$\pm 4.3$	mV	max	A	
Average Offset Voltage Drift	$V_{CM} = V_S/2$			$\pm 12$	$\pm 12$	$\mu V/^\circ C$	max	B	
Noninverting Input Bias Current	$V_{CM} = V_S/2$	$\pm 5$	<b><math>\pm 13</math></b>	$\pm 14.5$	$\pm 15$	$\mu A$	max	A	
Average Noninverting Input Bias Current Drift	$V_{CM} = V_S/2$			$\pm 25$	$\pm 30$	nA/ $^\circ C$	max	B	
Inverting Input Bias Current	$V_{CM} = V_S/2$	$\pm 5$	<b><math>\pm 13</math></b>	$\pm 14.5$	$\pm 16$	$\mu A$	max	A	
Average Inverting Input Bias Current Drift	$V_{CM} = V_S/2$			$\pm 25$	$\pm 30$	nA/ $^\circ C$	max	B	
<b>INPUT</b>									
Least Positive Input Voltage <sup>(5)</sup>		1.25	<b>1.32</b>	1.35	1.38	V	max	A	
Most Positive Input Voltage <sup>(5)</sup>		3.75	<b>3.68</b>	3.65	3.62	V	min	A	
Common-Mode Rejection Ratio (CMRR)	$V_{CM} = V_S/2$	58	<b>51</b>	50	50	dB	min	A	
Noninverting Input Impedance		50    1				k $\Omega$    pF	typ	C	
Inverting Input Resistance ( $R_i$ )	Open-Loop	5				$\Omega$	typ	C	
<b>OUTPUT</b>									
Most Positive Output Voltage	$R_L = 1k\Omega$ to $V_S/2$	4.10	<b>3.9</b>	3.9	3.8	V	min	A	
Least Positive Output Voltage	$R_L = 1k\Omega$ to $V_S/2$	0.9	<b>1.1</b>	1.1	1.2	V	max	A	
Current Output, Sourcing	$V_O = V_S/2$	80	<b>65</b>	60	55	mA	min	A	
Current Output, Sinking	$V_O = V_S/2$	70	<b>55</b>	50	45	mA	min	A	
Closed-Loop Output Impedance	$G = +2$ , $f = 100kHz$	0.006				$\Omega$	typ	C	
<b>POWER SUPPLY</b>									
Specified Single-Supply Operating Voltage		5				V	typ	C	
Max Single-Supply Operating Voltage Range			<b>12</b>	12	12	V	max	A	
Max Quiescent Current	$V_S = +5V$	5.8	<b>6.2</b>	6.2	6.2	mA	max	A	
Min Quiescent Current	$V_S = +5V$	5.8	<b>5.2</b>	4.8	4.6	mA	min	A	
Power-Supply Rejection Ratio (+PSRR)	Input Referred	58				dB	typ	C	
<b>TEMPERATURE RANGE</b>									
Specification: ID, IPW		-40 to +85				$^\circ C$	typ	C	
Thermal Resistance, $\theta_{JA}$ Junction-to-Ambient									
D SO-14		100				$^\circ C/W$	typ	C	
PW TSSOP-14		110				$^\circ C/W$	typ	C	

NOTES: (1) Junction temperature = ambient for 25°C tested specifications. (2) Junction temperature = ambient at low temperature limit, junction temperature = ambient +3°C at high temperature limit for over temperature tested specifications. (3) Test levels: (A) 100% tested at 25°C. Over temperature limits by characterization and simulation. (B) Limits set by characterization and simulation. (C) Typical value only for information. (4) Current is considered positive out-of-node.  $V_{CM}$  is the input common-mode voltage. (5) Tested < 3dB below minimum specified CMR at  $\pm$  CMIR limits.

# ELECTRICAL CHARACTERISTICS: $V_S = \pm 5V$

At  $T_A = +25^\circ C$ ,  $G = +2$ ,  $R_F = 800\Omega$ , and  $R_L = 100\Omega$ , unless otherwise noted.

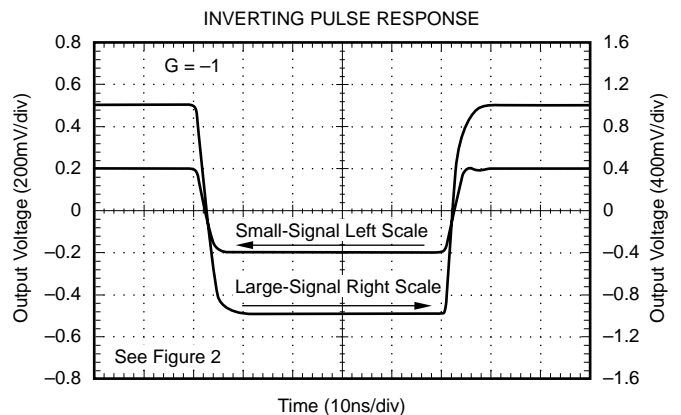
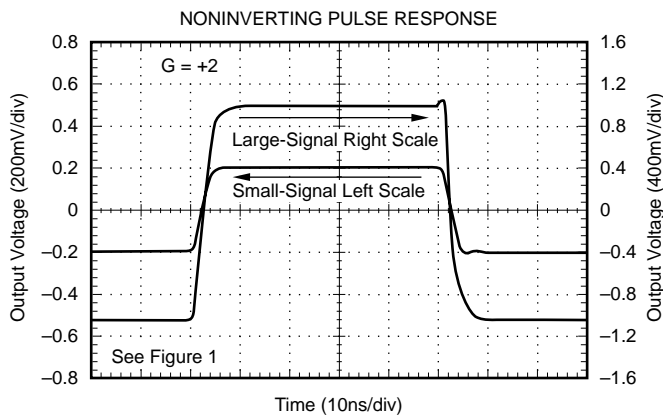
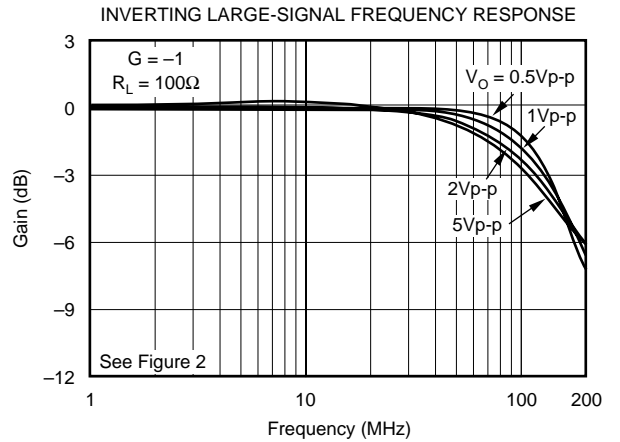
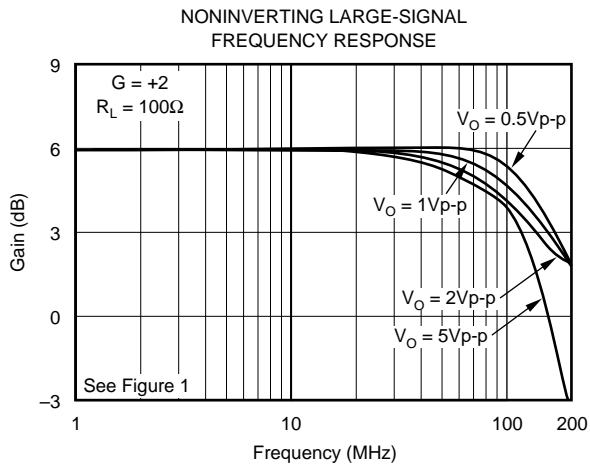
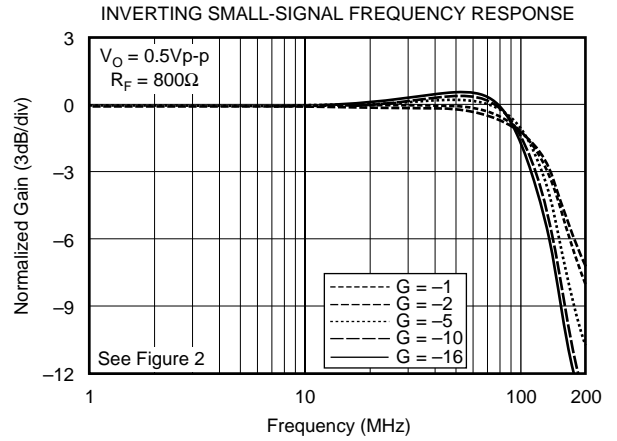
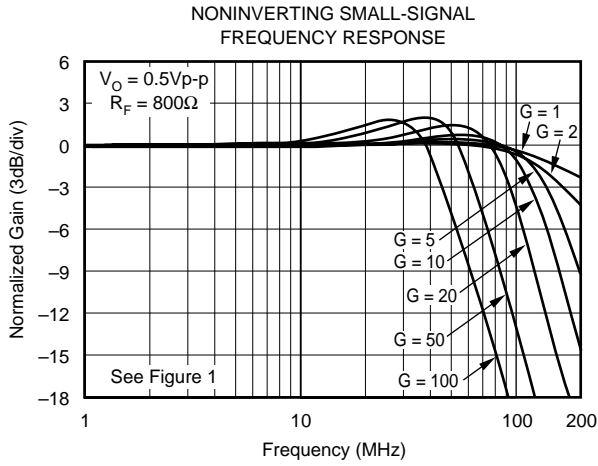

# ELECTRICAL CHARACTERISTICS: $V_S = \pm 5V$ (Cont.)

At  $T_A = +25^\circ C$ ,  $G = +2$ ,  $R_F = 800\Omega$ , and  $R_L = 100\Omega$ , unless otherwise noted.

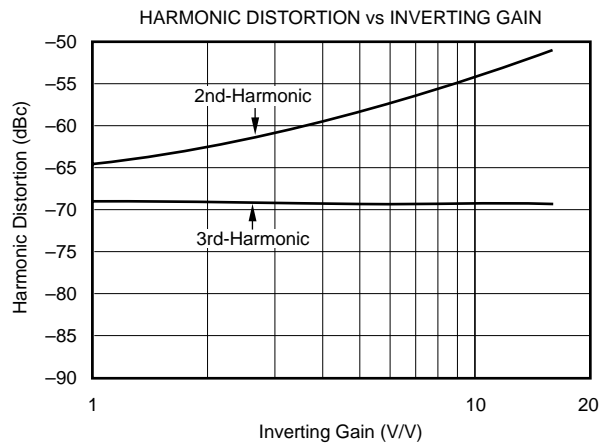
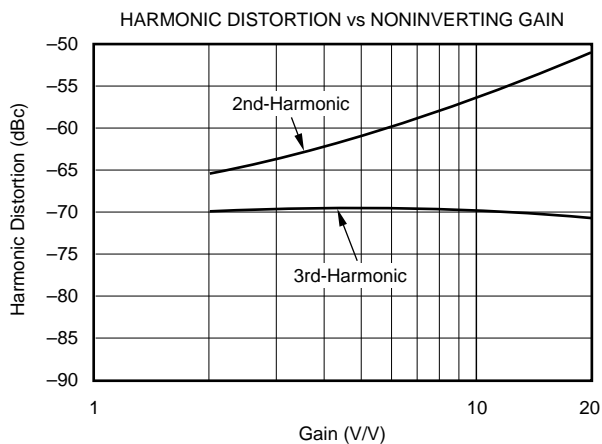
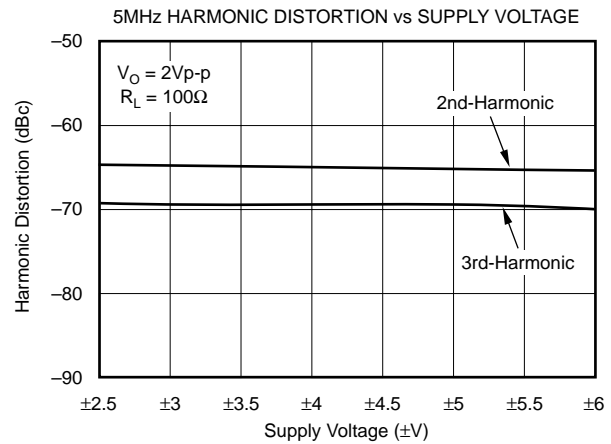
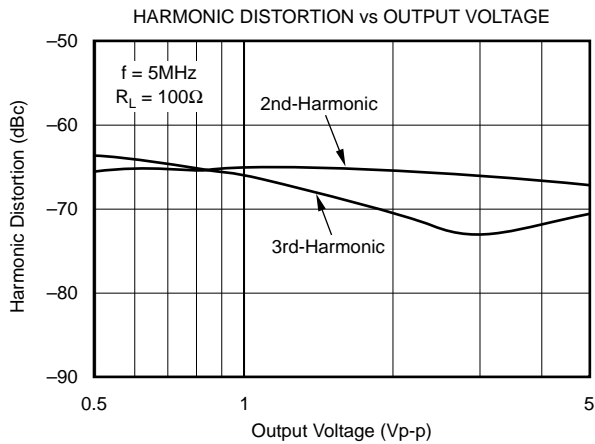
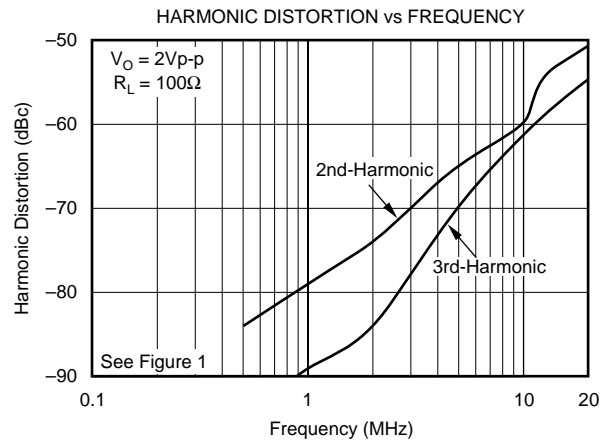
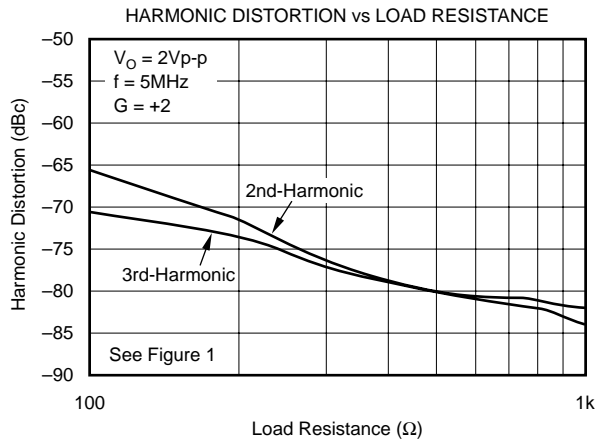

# ELECTRICAL CHARACTERISTICS: $V_S = \pm 5V$ (Cont.)

At  $T_A = +25^\circ C$ ,  $G = +2$ ,  $R_F = 800\Omega$ , and  $R_L = 100\Omega$ , unless otherwise noted.

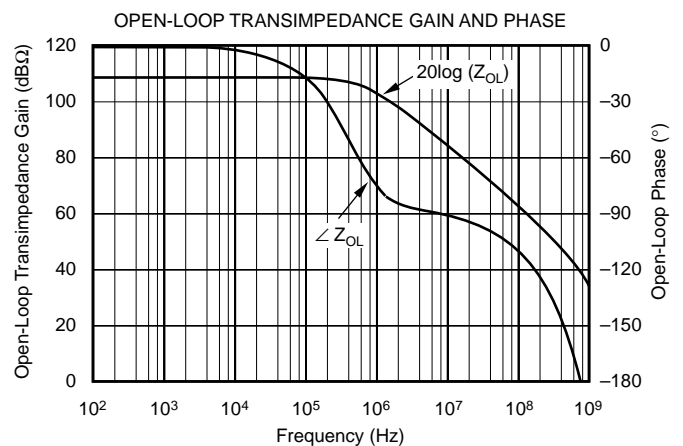
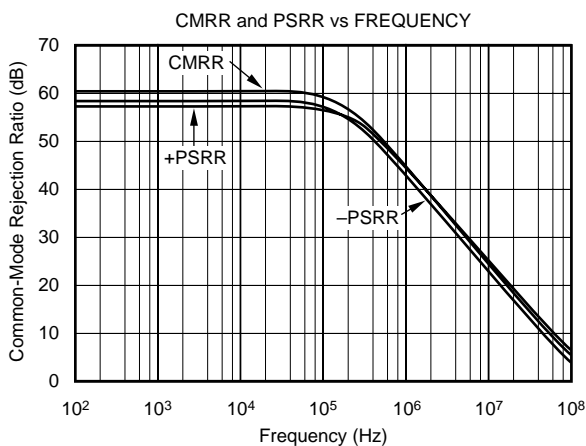
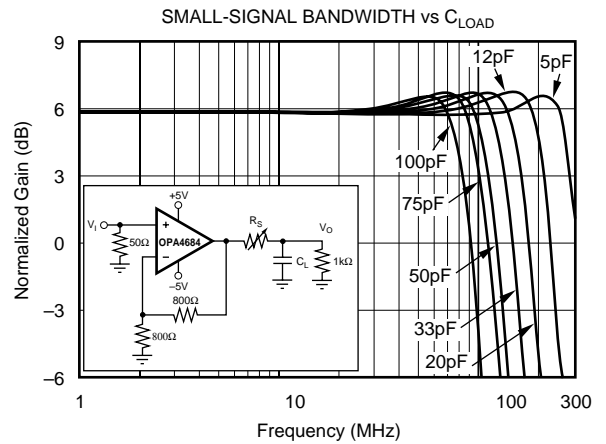
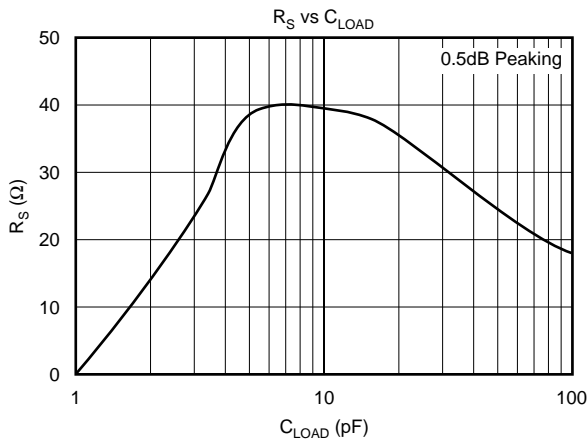
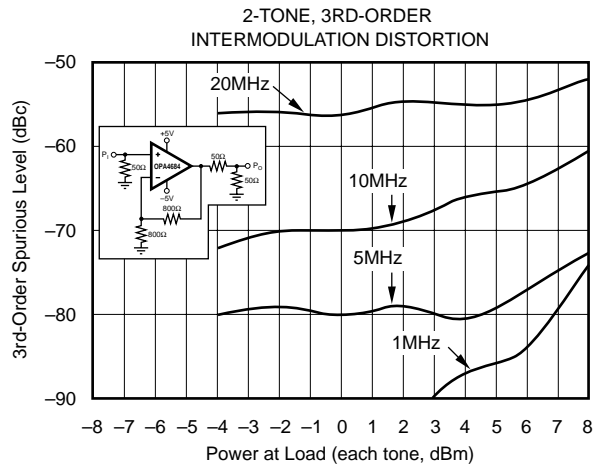
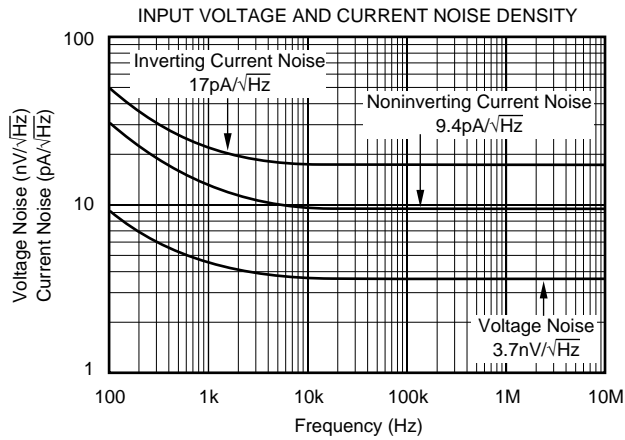

# ELECTRICAL CHARACTERISTICS: $V_S = \pm 5V$ (Cont.)

At  $T_A = +25^\circ C$ ,  $G = +2$ ,  $R_F = 800\Omega$ , and  $R_L = 100\Omega$ , unless otherwise noted.

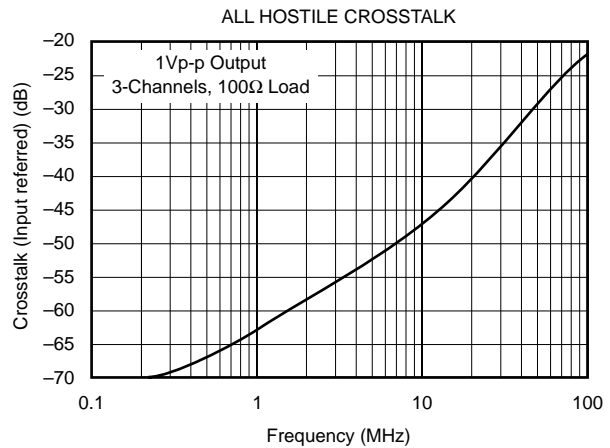
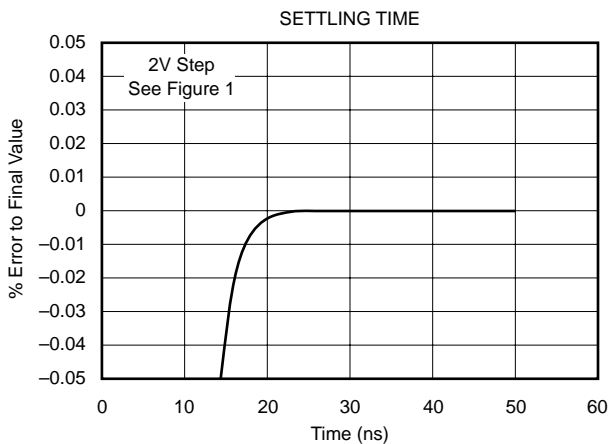
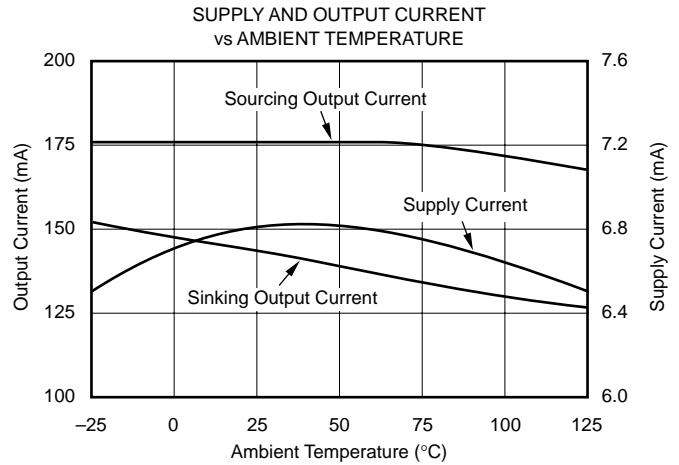
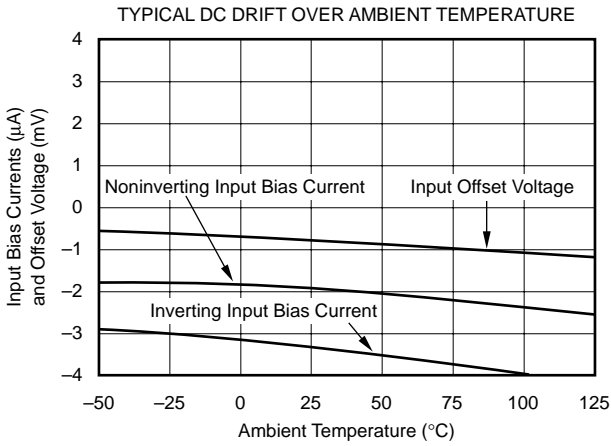
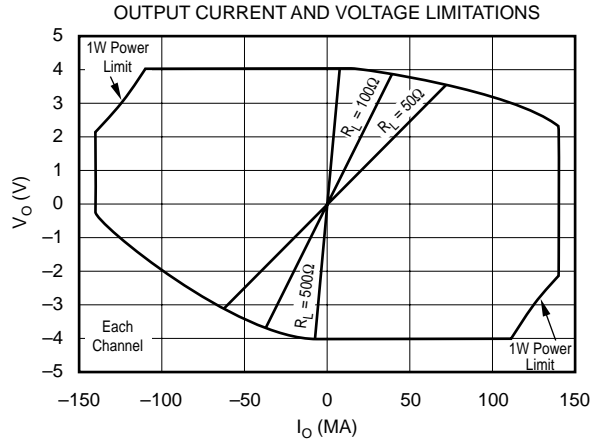
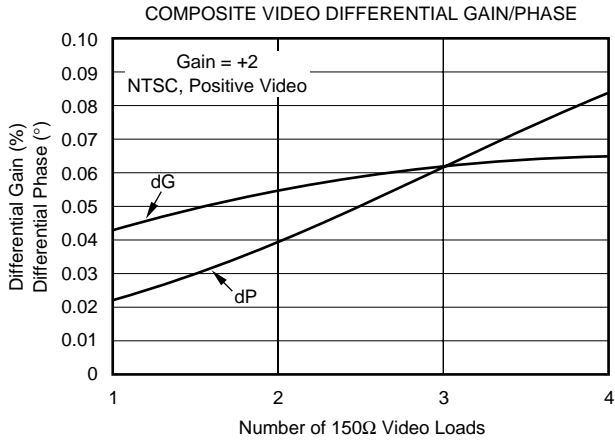



# ELECTRICAL CHARACTERISTICS: $V_S = \pm 5V$ (Cont.)

At  $T_A = +25^\circ C$ ,  $G = +2$ ,  $R_F = 800\Omega$ , and  $R_L = 100\Omega$ , unless otherwise noted.

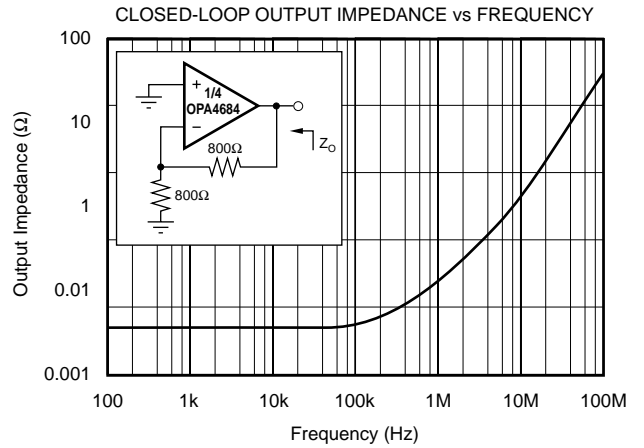
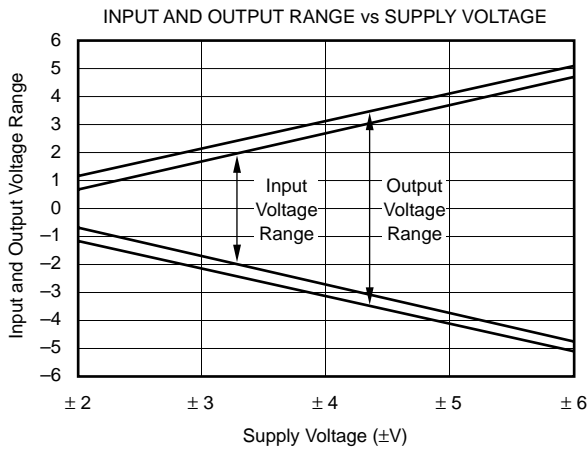
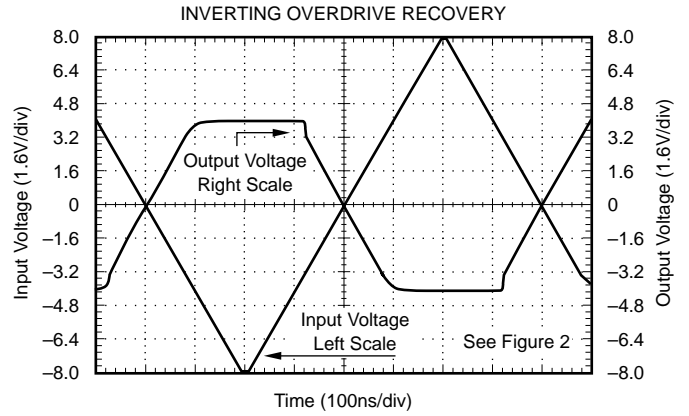
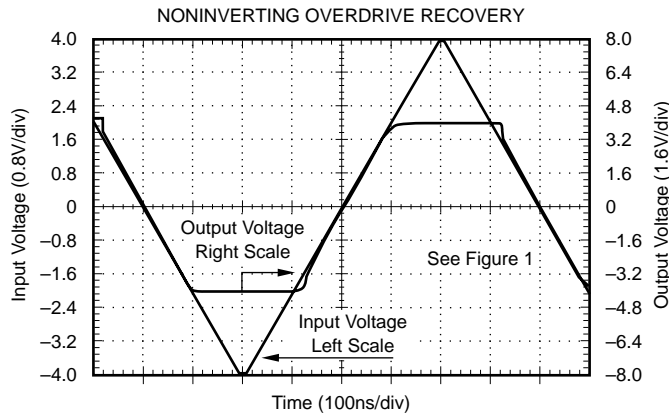

# ELECTRICAL CHARACTERISTICS: $V_S = +5V$

At  $T_A = +25^\circ C$ ,  $G = +2$ ,  $R_F = 1k\Omega$ , and  $R_L = 100\Omega$ , unless otherwise noted.

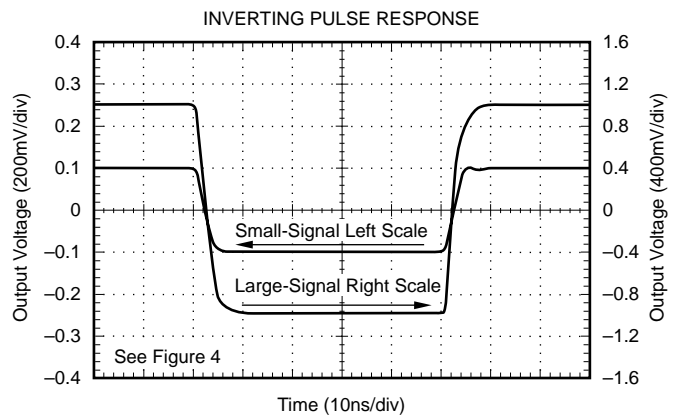
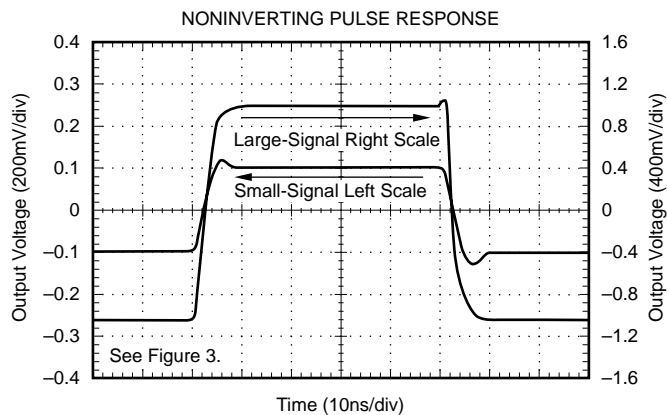
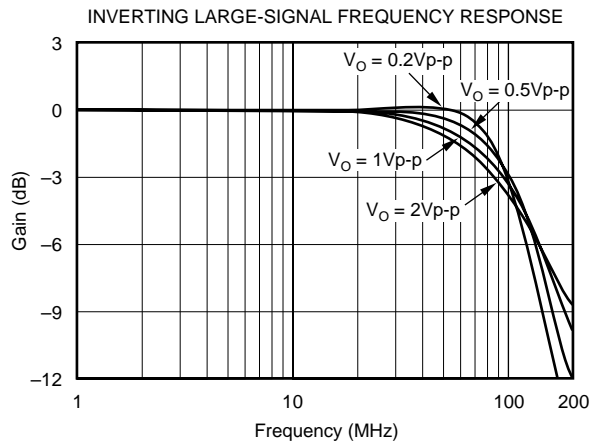
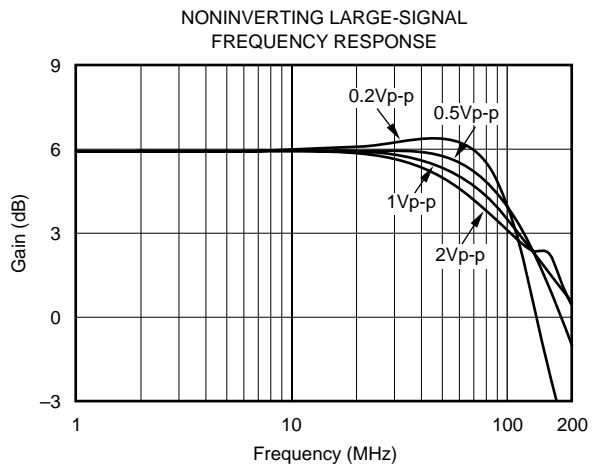
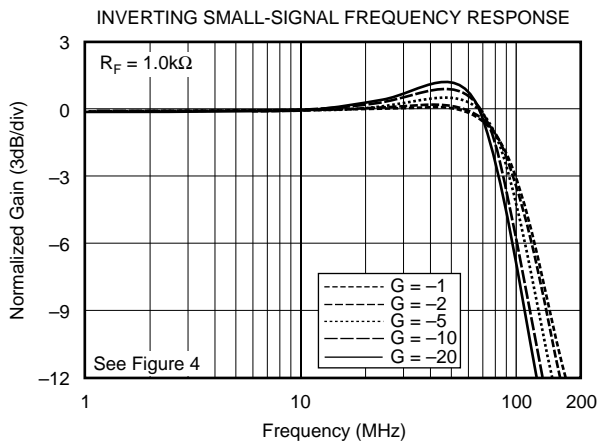
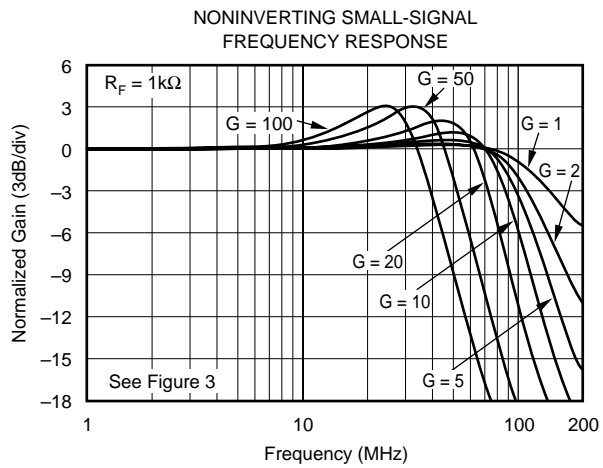

# ELECTRICAL CHARACTERISTICS: $V_S = +5V$ (Cont.)

At  $T_A = +25^\circ C$ ,  $G = +2$ ,  $R_F = 1k\Omega$ , and  $R_L = 100\Omega$ , unless otherwise noted.

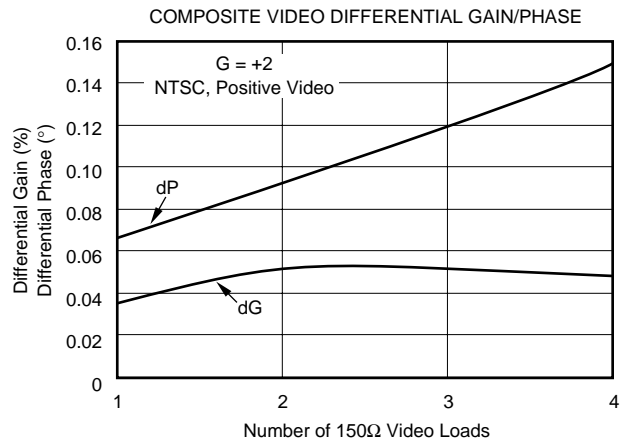
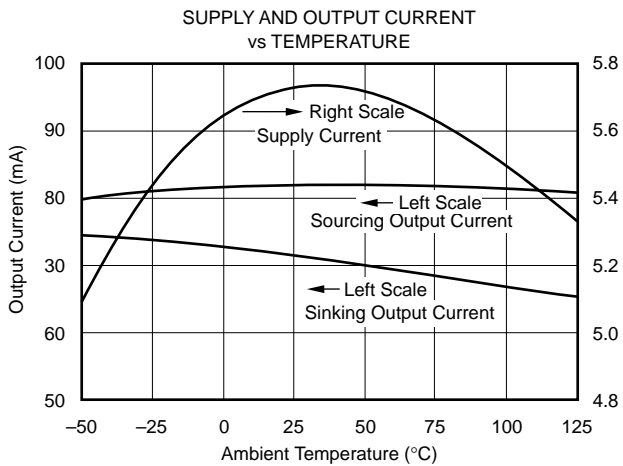
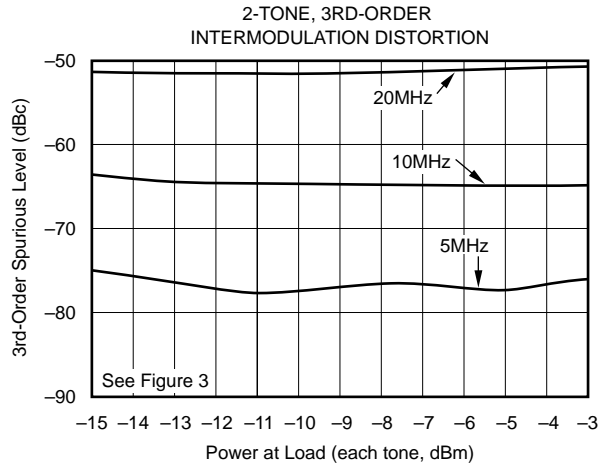
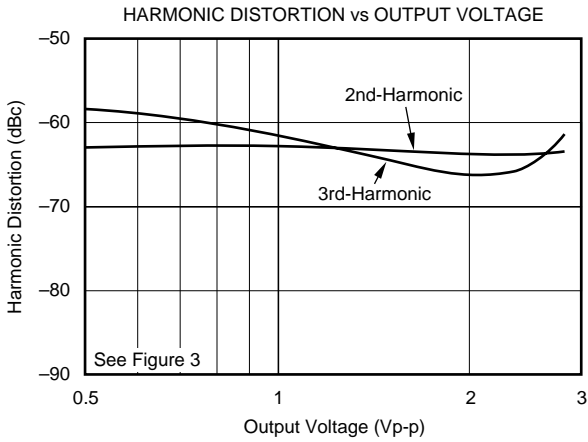
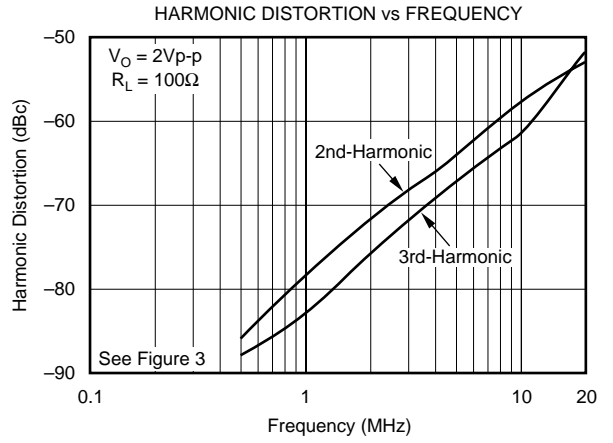
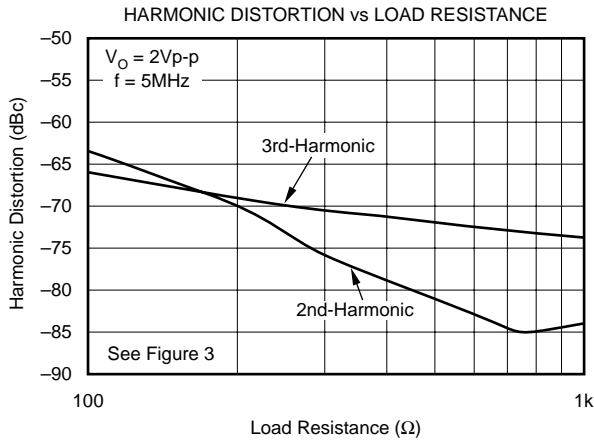

# APPLICATIONS INFORMATION

## LOW-POWER CURRENT-FEEDBACK OPERATION

The quad-channel OPA4684 gives a new level of performance in low-power current-feedback op amps. Using a new input stage buffer architecture, the OPA4684 CFB<sub>PLUS</sub> amplifier holds nearly constant AC performance over a wide gain range. This closed-loop internal buffer gives a very low and linearized impedance at the inverting node, isolating the amplifier's AC performance from gain element variations. This allows both the bandwidth and distortion to remain nearly constant over gain, moving closer to the ideal current feedback performance of gain bandwidth independence. This low-power amplifier also delivers exceptional output power—it's  $\pm 4V$  swing on  $\pm 5V$  supplies with  $> 100mA$  output drive gives excellent performance into standard video loads or doubly-terminated  $50\Omega$  cables. Single  $+5V$  supply operation is also supported with similar bandwidths but with reduced output power capability. For lower quiescent power in a CFB<sub>PLUS</sub> amplifier, consider the OPA683 family; while for higher output power, consider the OPA691 family.

Figure 1 shows the DC-coupled, gain of  $+2$ , dual power-supply circuit used as the basis of the  $\pm 5V$  Electrical and Typical Characteristics for each channel. For test purposes, the input impedance is set to  $50\Omega$  with a resistor to ground and the output impedance is set to  $50\Omega$  with a series output resistor. Voltage swings reported in the Electrical Characteristics are taken directly at the input and output pins while load powers (dBm) are defined at a matched  $50\Omega$  load. For the circuit of Figure 1, the total effective load will be  $100\Omega \parallel 1600\Omega = 94\Omega$ . Gain changes are most easily accomplished by simply resetting the  $R_G$  value, holding  $R_F$  constant at its recommended value of  $800\Omega$ .

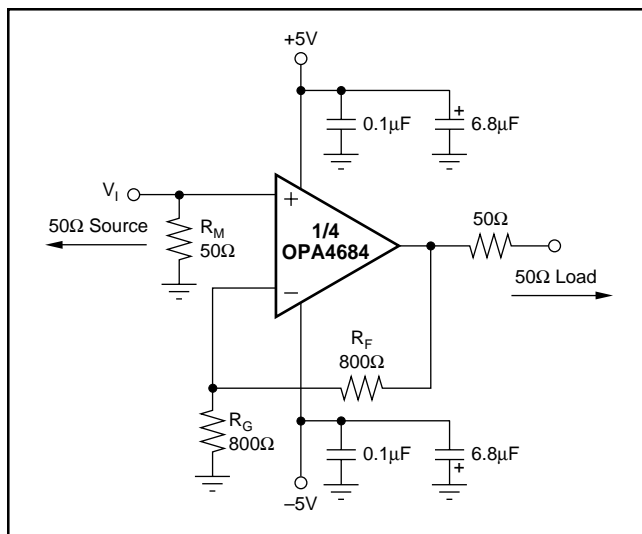

FIGURE 1. DC-Coupled,  $G = +2V/V$ , Bipolar Supply Specifications and Test Circuit.

Figure 2 shows the DC-coupled, gain of  $-1V/V$ , dual power-supply circuit used as the basis of the Inverting Typical Characteristics for each channel. Inverting operation offers several performance benefits. Since there is no common-

mode signal across the input stage, the slew rate for inverting operation is typically higher and the distortion performance is slightly improved. An additional input resistor,  $R_M$ , is included in Figure 2 to set the input impedance equal to  $50\Omega$ . The parallel combination of  $R_M$  and  $R_G$  set the input impedance. As the desired gain increases for the inverting configuration,  $R_G$  is adjusted to achieved the desired gain, while  $R_M$  is also adjusted to hold a  $50\Omega$  input match. A point will be reached where  $R_G$  will equal  $50\Omega$ ,  $R_M$  is removed, and the input match is set by  $R_G$  only. With  $R_G$  fixed to achieve an input match to  $50\Omega$ , increasing  $R_F$  will increase the gain. This will, however, quickly reduce the achievable bandwidth as the feedback resistor increases from its recommended value of  $800\Omega$ . If the source does not require an input match to  $50\Omega$ , either adjust  $R_M$  to get the desired load, or remove it and let the  $R_G$  resistor alone provide the input load.

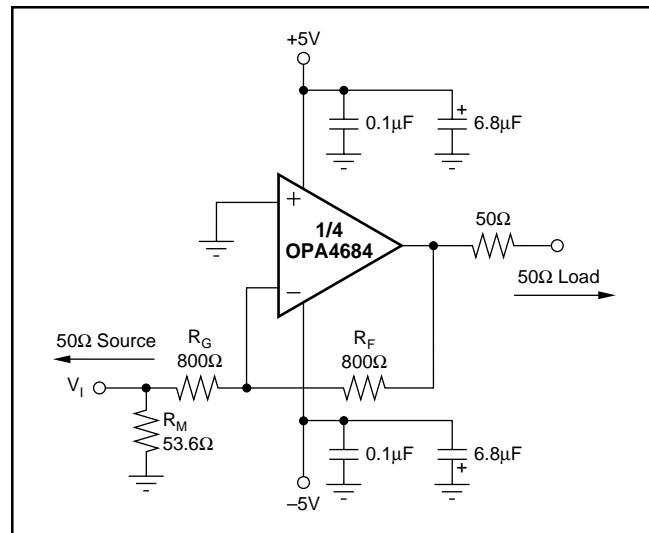

FIGURE 2. DC-Coupled,  $G = -1V/V$ , Bipolar Supply Specifications and Test Circuit.

These circuits show  $\pm 5V$  operation. The same circuits can be applied with bipolar supplies from  $\pm 2.5V$  to  $\pm 6V$ . Internal supply independent biasing gives nearly the same performance for the OPA4684 over this wide range of supplies. Generally, the optimum feedback resistor value (for nominally flat frequency response at  $G = +2$ ) will increase in value as the total supply voltage across the OPA4684 is reduced. See Figure 3 for the AC-coupled, single  $+5V$  supply, gain of  $+2V/V$  circuit configuration used as a basis for the  $+5V$  only Electrical and Typical Characteristics for each channel. The key requirement of broadband single-supply operation is to maintain input and output signal swings within the usable voltage ranges at both the input and the output. The circuit of Figure 3 establishes an input midpoint bias using a simple resistive divider from the  $+5V$  supply (two  $10k\Omega$  resistors) to the noninverting input. The input signal is then AC-coupled into this midpoint voltage bias. The input voltage can swing to within  $1.25V$  of either supply pin, giving a  $2.5Vp-p$  input signal range centered between the supply pins. The input impedance of Figure 3 is set to give a  $50\Omega$  input match. If the source does not require a  $50\Omega$  match, remove this and drive

directly into the blocking capacitor. The source will then see the  $5k\Omega$  load of the biasing network as a load. The gain resistor ( $R_G$ ) is AC-coupled, giving the circuit a DC gain of +1, which puts the noninverting input DC bias voltage (2.5V) on the output as well. The feedback resistor value has been adjusted from the bipolar  $\pm 5V$  supply condition to re-optimize for a flat frequency response in +5V only, gain of +2, operation. On a single +5V supply, the output voltage can swing to within 1.0V of either supply pin while delivering more than 70mA output current—easily giving a 3Vp-p output swing into  $100\Omega$  (8dBm maximum at the matched  $50\Omega$  load). The circuit of Figure 3 shows a blocking capacitor driving into a  $50\Omega$  output resistor, then into a  $50\Omega$  load. Alternatively, the blocking capacitor could be removed if the load is tied to a supply midpoint or to ground if the DC current required by the load is acceptable.

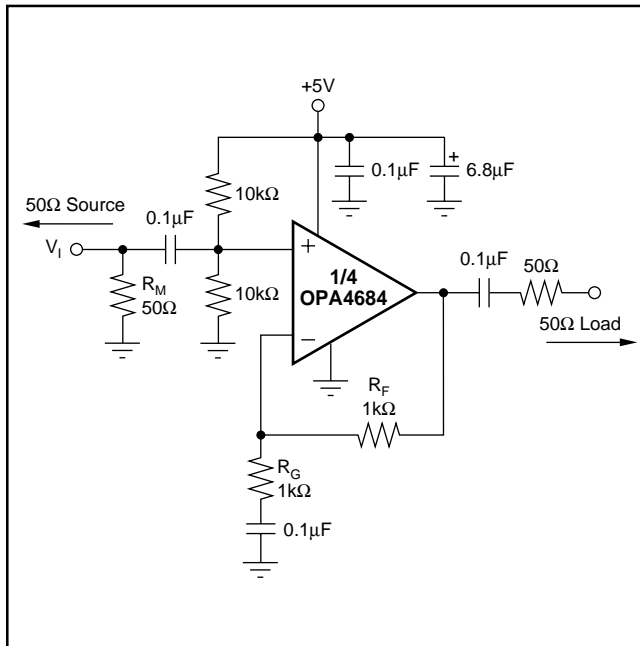

FIGURE 3. AC-Coupled,  $G = +2V/V$ , Single-Supply Specifications and Test Circuit.

Figure 4 shows the AC-coupled, single +5V supply, gain of  $-1V/V$  circuit configuration used as a basis for the inverting +5V only Typical Characteristics for each channel. In this case, the midpoint DC bias on the noninverting input is also decoupled with an additional  $0.1\mu F$  capacitor. This reduces the source impedance at higher frequencies for the noninverting input bias current noise. This 2.5V bias on the noninverting input pin appears on the inverting input pin and, since  $R_G$  is DC-blocked by the input capacitor, will also appear at the output pin. One advantage to inverting operation is that since there is no signal swing across the input stage, higher slew rates and operation to even lower supply voltages is possible. To retain a 1Vp-p output capability, operation down to a 3V supply is allowed. At a +3V supply, the input stage is saturated, but for the inverting configuration of a current-feedback amplifier, wideband operation is retained even under this condition.

The circuits of Figure 3 and 4 show single-supply operation at +5V. These same circuits may be used up to single supplies of +12V with minimal change in the performance of the OPA4684.

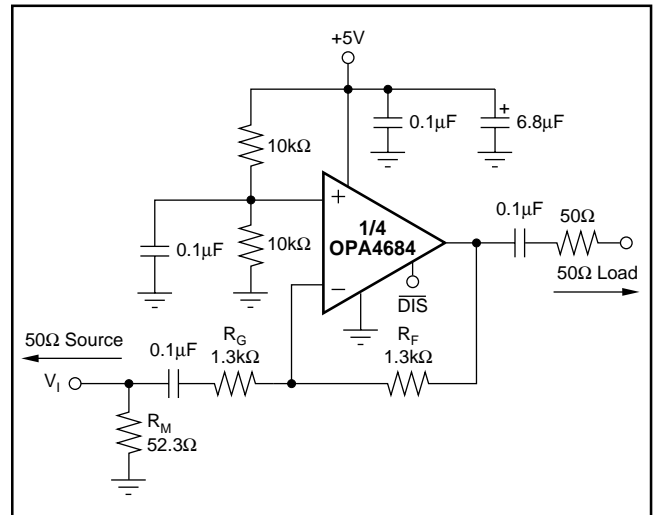

FIGURE 4. AC-Coupled,  $G = -1V/V$ , Single-Supply Specifications and Test Circuit.

## DIFFERENTIAL INTERFACE APPLICATIONS

Dual and quad op amps are particularly suitable to differential input to differential output applications. Typically, these fall into either ADC input interface or line driver applications. Two basic approaches to differential I/O are noninverting or inverting configurations. Since the output is differential, the signal polarity is somewhat meaningless—the noninverting and inverting terminology applies here to where the input is brought into the OPA4684. Each has its advantages and disadvantages. Figure 5 shows a basic starting point for noninverting differential I/O applications.

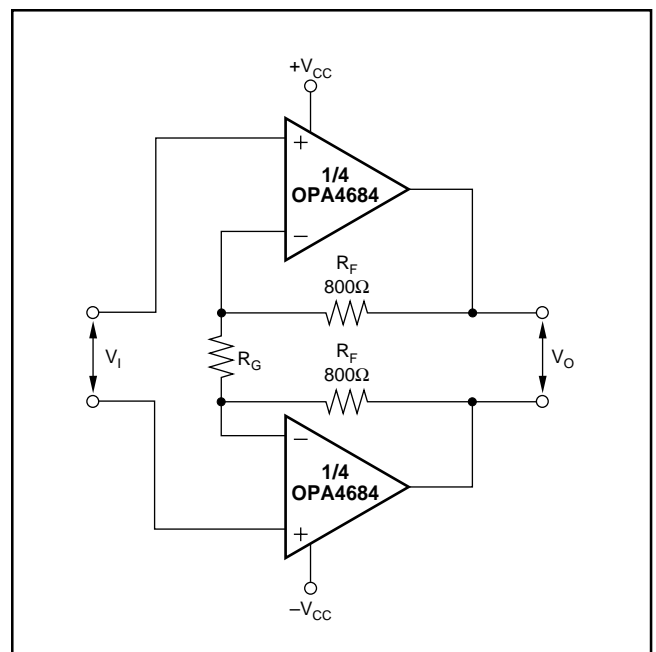

FIGURE 5. Noninverting Differential I/O Amplifier.

This approach provides for a source termination impedance that is independent of the signal gain. For instance, simple differential filters may be included in the signal path right up to the noninverting inputs without interacting with the amplifier gain. The differential signal gain for the circuit of Figure 5 is:

$$V_O/V_I = A_D = 1 + 2 \cdot R_F/R_G$$

Since the OPA4684 is a CFB<sub>PLUS</sub> amplifier, its bandwidth is principally controlled with the feedback resistor value; Figure 5 shows the recommended value of 800Ω. However, the gain may be adjusted with considerable freedom using just the R<sub>G</sub> resistor. In fact, R<sub>G</sub> may be a reactive network providing a very isolated shaping to the differential frequency response. Since the inverting inputs of the OPA4684 are very low impedance closed-loop buffer outputs, the R<sub>G</sub> element does not interact with the amplifier's bandwidth—wide ranges of resistor values and/or filter elements may be inserted here with minimal amplifier bandwidth interaction.

Various combinations of single-supply or AC-coupled gains can also be delivered using the basic circuit of Figure 5. Common-mode bias voltages on the two noninverting inputs pass on to the output with a gain of 1 since an equal DC voltage at each inverting node creates no current through R<sub>G</sub>, giving that voltage a common-mode gain of 1 to the output.

Figure 6 shows a differential I/O stage configured as an inverting amplifier. In this case, the gain resistors (R<sub>G</sub>) become the input resistance for the source. This provides a better noise performance than the noninverting configuration but does limit the flexibility in setting the input impedance separately from the gain.

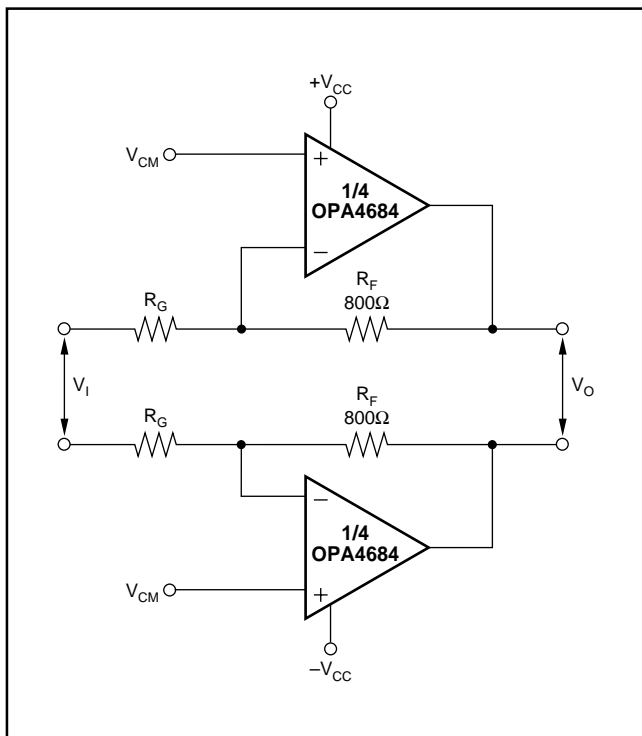

FIGURE 6. Inverting Differential I/O Amplifier.

The two noninverting inputs provide an easy common-mode control input. This is particularly useful if the source is AC-coupled through either blocking caps or a transformer. In either case, the common-mode input voltages on the two noninverting inputs again have a gain of 1 to the output pins, giving an easy common-mode control for single-supply operation. The OPA4684 used in this configuration does constrain the feedback to the 800Ω region for best frequency response. With R<sub>F</sub> fixed, the input resistors may be adjusted to the desired gain but will also be changing the input impedance as well. The differential gain for this circuit is:

$$V_O/V_I = -R_F/R_G$$

## LOW-POWER VIDEO LINE DRIVER APPLICATIONS

For low-power, video line driving, the OPA4684 provides the output current and linearity to support 4 channels of either single video lines, or up to 4 video lines in parallel on each output. Figure 7 shows a typical ±5V supply video line driver application where only one channel is shown and only a single line is being driven. The improved 2nd-harmonic distortion of the CFB<sub>PLUS</sub> architecture, along with the OPA684's high output current and voltage, gives exceptional differential gain and phase performance for a low-power solution. As the Typical Characteristics show, a single video load shows a dG/dP of 0.04%/0.02°. Multiple loads may be driven on each output, with minimal x-talk, while the dG/dP is still < 0.1%/0.1° for up to 4 parallel video loads.

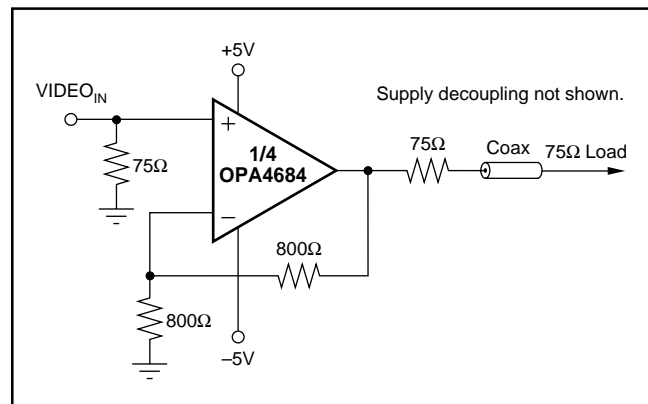

FIGURE 7. Gain of +2 Video Cable Driver.

## DC-COUPLED SINGLE-TO-DIFFERENTIAL CONVERSION

The previous differential output circuits were set up to receive a differential input as well as provide a differential output. Figure 8 shows one way to provide a single to differential conversion, with DC coupling, and independent output common-mode control using a quad op amp.

The circuit of Figure 8 provides several useful features for isolating the input signal from the final outputs. Using the first amplifier as a simple noninverting stage gives an independent adjustment on R<sub>I</sub> (to set the source loading) while the gain can be easily adjusting in this stage using the R<sub>G</sub> resistor. Bandwidth is relatively independent of gain setting in the OPA4684. The next stage allows a separate output

common-mode level to be set up. The desired output common-mode voltage,  $V_{CM}$ , is cut in half and applied to the noninverting input of the 2nd stage. The signal path in this stage sees a gain of  $-1$  while this  $(1/2 \cdot V_{CM})$  voltage sees a gain of  $+2$ . The output of this 2nd stage is then the original common-mode voltage plus the inverted signal from the output of the first stage. The output of this 2nd stage then appears directly at the output of the noninverting final stage. The inverting node of the inverting output stage is also biased to the common-mode voltage, equal to the common-mode voltage appearing at the output of the 2nd stage, creating no current flow and placing the desired  $V_{CM}$  at the output of this stage as well.

### LOW-POWER, DIFFERENTIAL I/O, 4th-ORDER ACTIVE FILTER

The OPA4684 can give a very capable gain block for low-power active filters. The quad design lends itself very well to

differential active filters. Where the filter topology is looking for a simple gain function to implement the filter, the noninverting configuration is preferred to isolate the filter elements from the gain elements in the design. Figure 9 shows an example of a very low-power, 10MHz, 4th-order Butterworth, low-pass Sallen-Key filter. Often, these filters are designed at an amplifier gain of 1 to minimize amplifier bandwidth interaction with the desired filter shape. Since the OPA4684 shows minimal bandwidth change with gain, this would not be a constraint in this design. The example of Figure 9 designs the filter for a differential gain of 4 in each differential stage. This DC-coupled design gives a signal gain of  $16V/V$  in the passband with  $f_{-3dB}$  at 10MHz. The design places the higher Q stage first to allow the lower Q 2nd stage to roll off the peaked noise of the first stage. The resistor values have been adjusted slightly to account for the amplifier group delay.

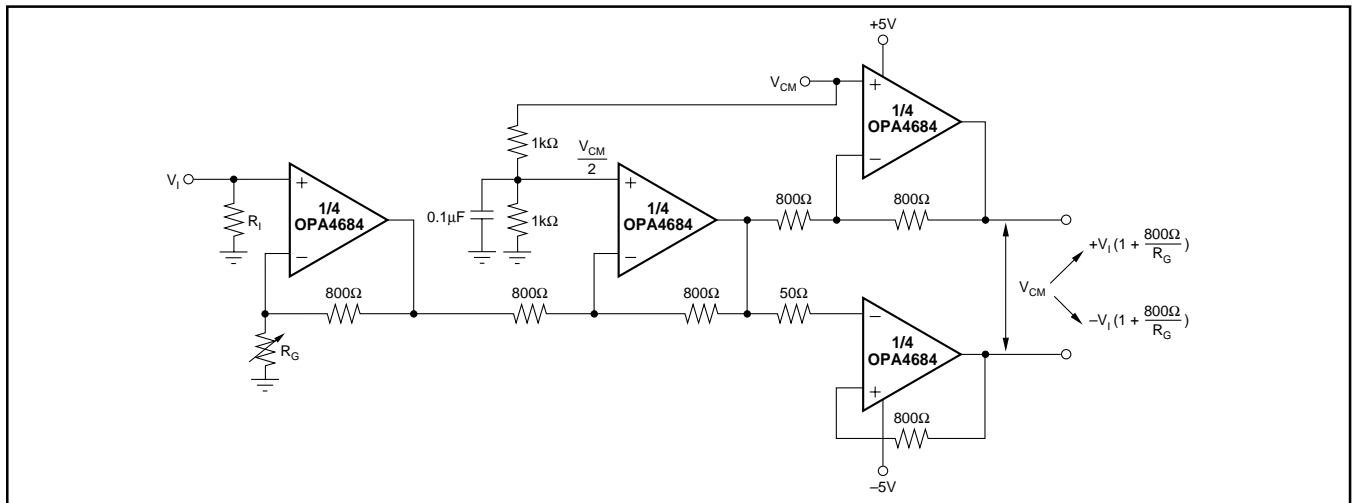

FIGURE 8. High Gain, DC-Coupled, Single to Differential Conversion.

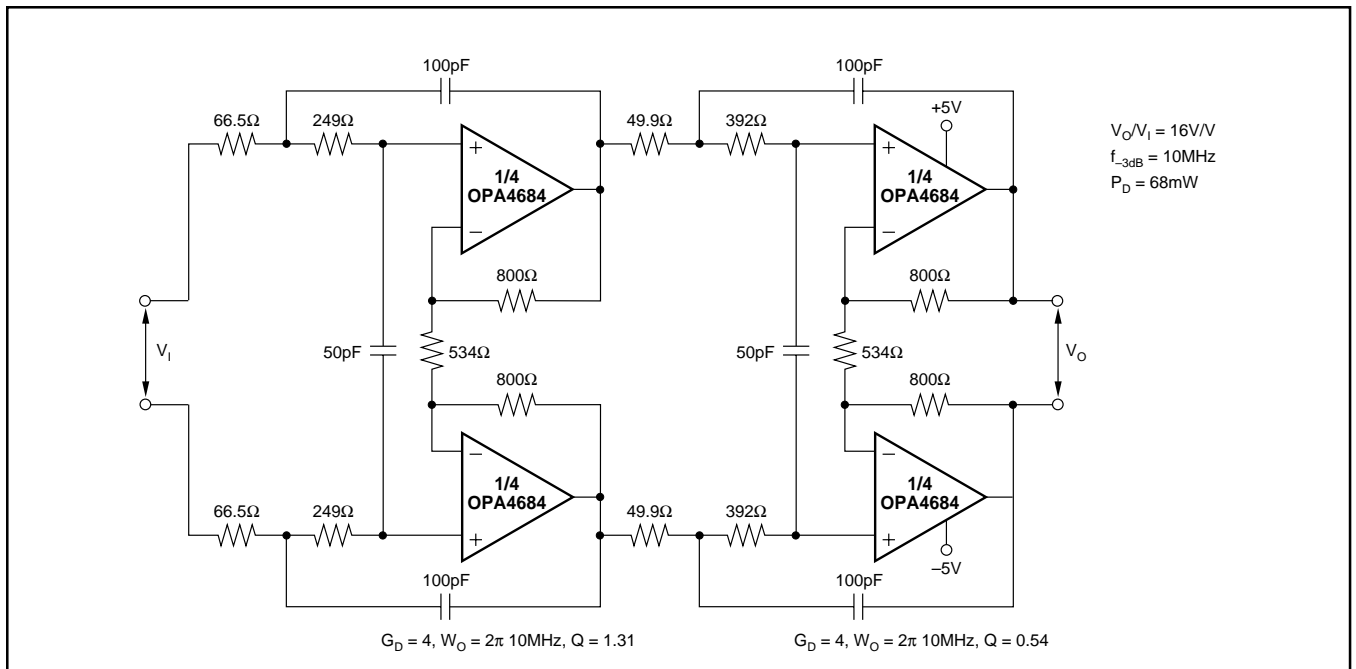

FIGURE 9. Low-Power, Differential I/O, 4th-Order Butterworth Active Filter.

While this circuit is bipolar, using  $\pm 5V$  supplies, it can easily be adapted to single-supply operation. This is typically done by providing a supply midpoint reference at the noninverting inputs then adding DC-blocking caps at each input and in series with the amplifier gain resistor,  $R_G$ . This will add two real zeroes in the response, transforming this circuit into a bandpass. Figure 10 shows the frequency response for the filter of Figure 9.

### LOW-POWER DSL TRANSCEIVER INTERFACE

With four amplifiers available, the quad OPA4684 can meet the needs for both differential driver and receiver in a low-power xDSL line interface design. Figure 11 shows a simplified design example. Two amplifiers are used as a noninverting differential driver while the other two implement the driver echo cancellation and receiver amplifier function. This example shows a single +12V design where the drive side is taking a 2Vp-p maximum input from the transmit filter and providing a differential gain of 7, giving a maximum 14Vp-p differential output swing. This is coupled through 50Ω matching resistors and a 1:1 transformer to give a maximum 7Vp-p on a 100Ω line. This 7Vp-p corresponds to a 10dBm line power with a 3.5 crest factor.

The differential receiver is configured as an inverting summing stage where the outputs of the driver are cancelled prior to appearing at the output of the receive amplifiers. This is done by summing the output voltages for the drive amplifiers

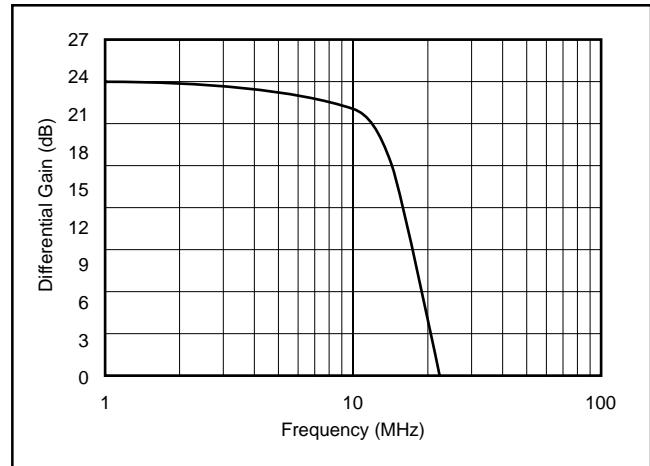

FIGURE 10. Low-Power, Differential 4th-Order, 100MHz Butterworth.

and their attenuated and inverted levels (at the transformer input) into the inverting inputs of each receiver amplifier. The resistor values are set in Figure 11 to give perfect drive signal cancellation if the drive signal is attenuated by 1/2 going from the drive amplifier outputs to the transformer input. The signal received through the transformer has a gain of 1 through the receive amplifiers. Higher gain could easily be provided by scaling the resistors summing into the inverting inputs of the receiver amplifiers down while keeping the same ratio between them.

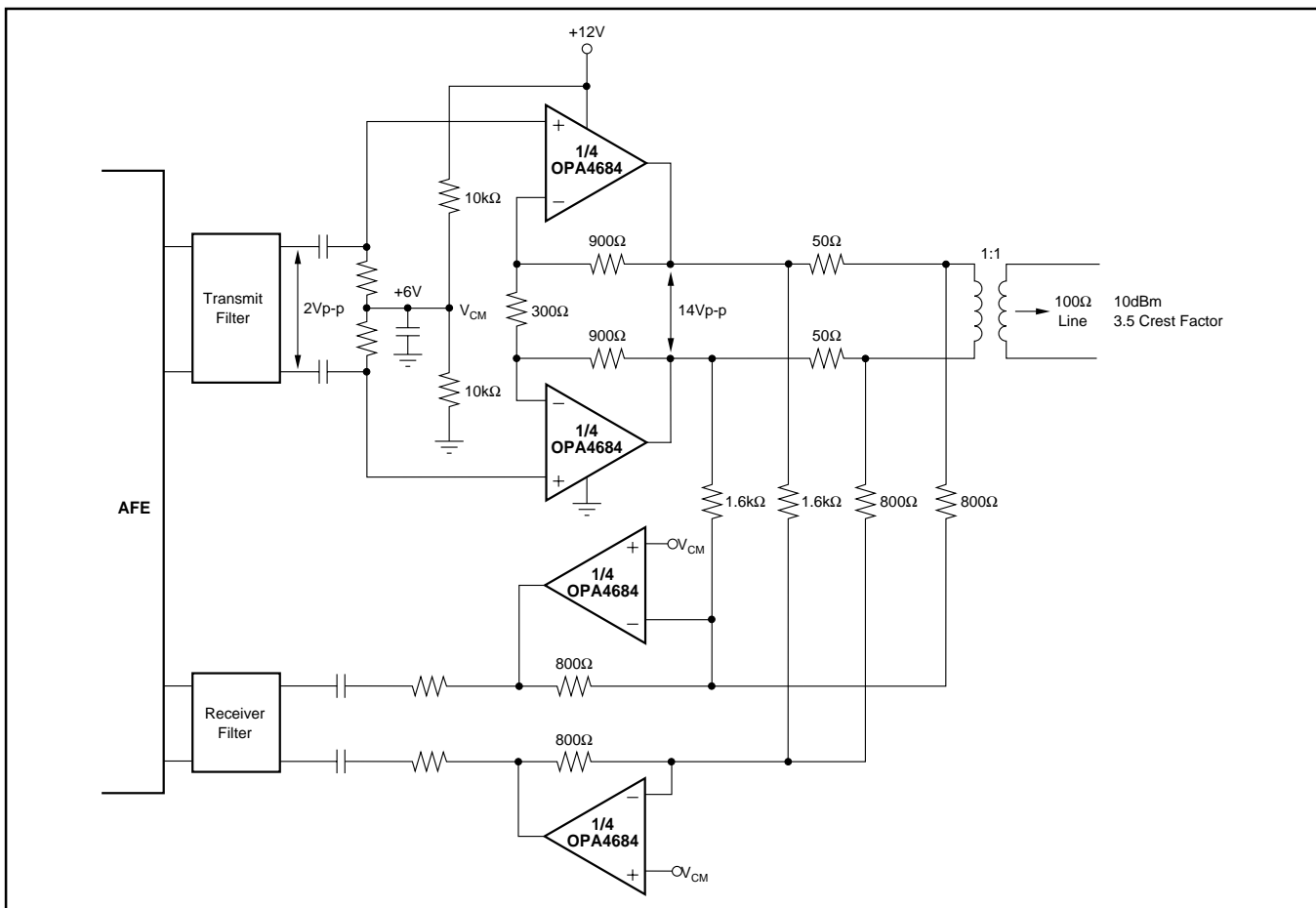

FIGURE 11. Low-Power, XDSL Transceiver Design.



## DUAL-CHANNEL, DIFFERENTIAL ADC DRIVER

Where a low-power, single-supply, interface to a differential input +5V ADC is required, the circuit of Figure 12 can provide a high dynamic range, medium gain interface for dual high-performance ADCs. The circuit of Figure 12 uses two amplifiers in the differential inverting configuration. The common-mode voltage is set on the noninverting inputs to the supply midscale. In this example, the input signal is coupled in through a 1:2 transformer. This provides both signal gain, single to differential conversion, and a reduction in noise figure. To show a 50Ω input impedance at the input to the transformer, two 200Ω resistors are required on the transformer secondary. These two resistors are also the amplifier gain elements. Since the same DC voltage appears on both inverting nodes in the circuit of Figure 12, no DC current will flow through the transformer, giving a DC gain of 1 to the output for this common-mode voltage,  $V_{CM}$ .

The circuit of Figure 12 is particularly suitable for a moderate resolution dual ADC used as I/Q samplers. The optional 500Ω resistors to ground on each amplifier output can be added to improve the 2nd- and 3rd-harmonic distortion by > 15dB if higher dynamic range is required. Figure 13 shows the harmonic distortion for the circuit of Figure 12 with and without these pull-down resistors. The 5mA added output stage current significantly improves linearity if that is required. The measured 2nd-harmonic distortion is consistently lower than the 3rd-harmonics for this balanced differential design. It is particularly helpful for this low-power design if there are no grounds in the signal path after the low-level signal at the transformer input. The two pull-down resistors do show a signal path ground and should be connected at the same physical point to ground to eliminate imbalanced ground return currents from degrading 2nd-harmonic distortion.

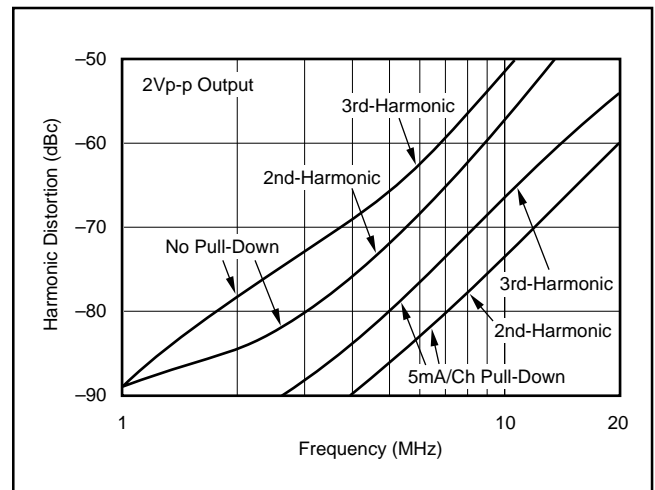

FIGURE 13. Harmonic Distortion vs Frequency.

## DESIGN-IN TOOLS

### DEMONSTRATION BOARDS

Two PC boards are available to assist in the initial evaluation of circuit performance using the OPA4684 in its two package styles. Both of these are available, free, as an unpopulated PC board delivered with descriptive documentation. The summary information for these boards is shown in Table I below.

PRODUCT	PACKAGE	BOARD PART NUMBER	LITERATURE REQUEST NUMBER
OPA4684ID	SO-14	DEM-OPA468xD	SB0U016
OPA4684IDBW	TSSOP-14	DEM-OPA46xxDPW	—

TABLE I. Evaluation Module Ordering Information.

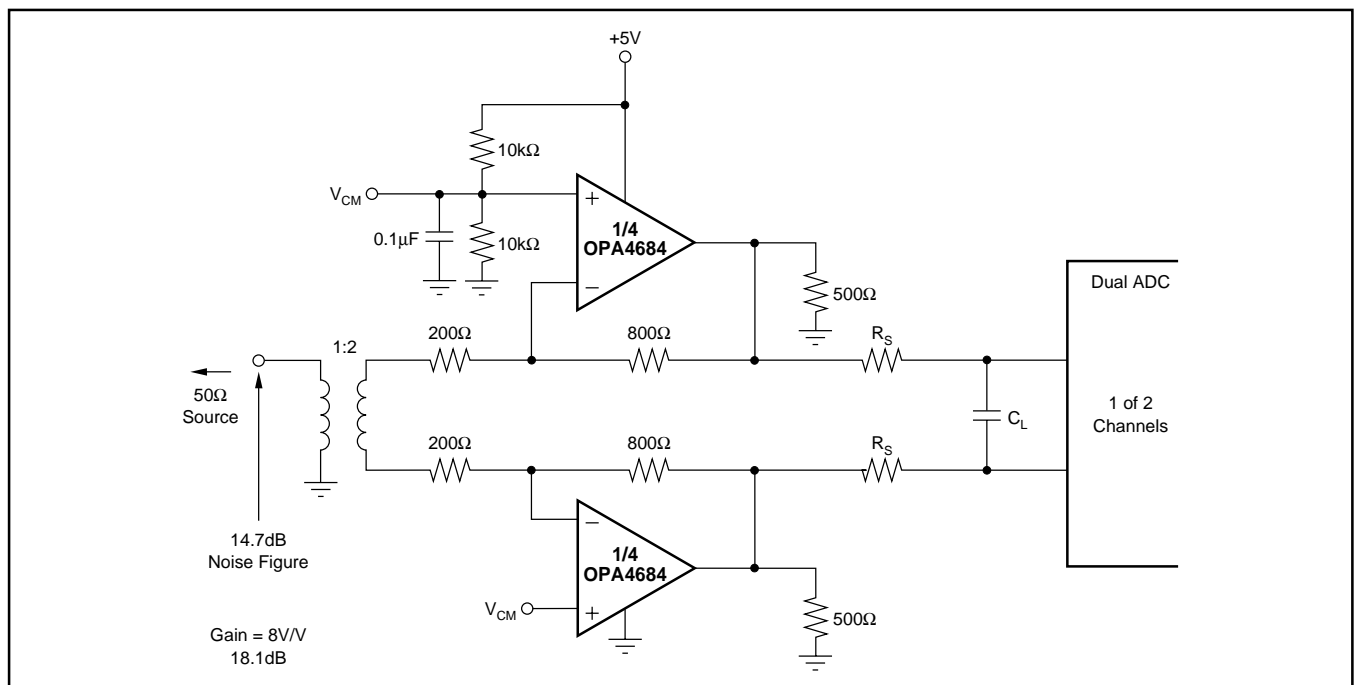

FIGURE 12. Single-Supply Differential ADC Driver (1 of 2 Channels).

## MACROMODELS

Computer simulation of circuit performance using SPICE is often useful in predicting the performance of analog circuits and systems. This is particularly true for Video and RF amplifier circuits where parasitic capacitance and inductance can have a major effect on circuit performance. Check the TI web site ([www.ti.com](http://www.ti.com)) for SPICE macromodels within the OPA4684 product folder. These models do a good job of predicting small-signal AC and transient performance under a wide variety of operating conditions. They do not do as well in predicting distortion or dG/dP characteristics. These models do not attempt to distinguish between the package types in their small-signal AC performance.

## OPERATING SUGGESTIONS

### SETTING RESISTOR VALUES TO OPTIMIZE BANDWIDTH

Any current-feedback op amp like the OPA4684 can hold high bandwidth over signal-gain settings with the proper adjustment of the external resistor values. A low-power part like the OPA4684 typically shows a larger change in bandwidth due to the significant contribution of the inverting input impedance to loop-gain changes as the signal gain is changed. Figure 14 shows a simplified analysis circuit for any current-feedback amplifier.

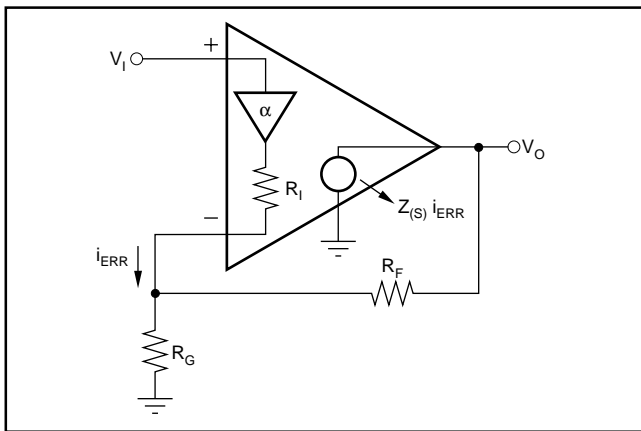

FIGURE 14. Current-Feedback Transfer Function Analysis Circuit.

The key elements of this current-feedback op amp model are:

$\alpha \Rightarrow$  Buffer gain from the noninverting input to the inverting input

$R_I \Rightarrow$  Buffer output impedance

$i_{ERR} \Rightarrow$  Feedback error current signal

$Z(s) \Rightarrow$  Frequency-dependent open-loop transimpedance gain from  $i_{ERR}$  to  $V_O$

The buffer gain is typically very close to 1.00 and is normally neglected from signal gain considerations. It will, however, set the CMRR for a single op amp differential amplifier configuration. For the buffer gain  $\alpha < 1.0$ , the  $CMRR = -20 \cdot \log(1 - \alpha)$ . The closed-loop input stage buffer used in the OPA4684 gives a buffer gain more closely

approaching 1.00 and this shows up in a slightly higher CMRR than previous current-feedback op amps.

$R_I$ , the buffer output impedance, is a critical portion of the bandwidth control equation. The OPA4684 reduces this element to approximately  $4.0\Omega$  using the local loop gain of the input buffer stage. This significant reduction in output impedance, on very low power, contributes significantly to extending the bandwidth at higher gains.

A current-feedback op amp senses an error current in the inverting node (as opposed to a differential input error voltage for a voltage-feedback op amp) and passes this on to the output through an internal frequency-dependent transimpedance gain. The Typical Characteristics show this open-loop transimpedance response. This is analogous to the open-loop voltage gain curve for a voltage-feedback op amp. Developing the transfer function for the circuit of Figure 13 gives Equation 1:

$$\frac{V_O}{V_I} = \frac{\alpha \left( 1 + \frac{R_F}{R_G} \right)}{R_F + R_I \left( 1 + \frac{R_F}{R_G} \right) + \frac{Z(s)}{1 + \frac{R_F}{R_G}}} = \frac{\alpha NG}{1 + \frac{R_F + R_I NG}{Z(s)}} \quad (1)$$

$$\left[ NG = \left( 1 + \frac{R_F}{R_G} \right) \right]$$

This is written in a loop-gain analysis format where the errors arising from a non-infinite open-loop gain are shown in the denominator. If  $Z(s)$  were infinite over all frequencies, the denominator of Equation 1 would reduce to 1 and the ideal desired signal gain shown in the numerator would be achieved. The fraction in the denominator of Equation 1 determines the frequency response. Equation 2 shows this as the loop-gain equation.

$$\frac{Z(s)}{R_F + R_I NG} = \text{Loop Gain} \quad (2)$$

If  $20 \cdot \log(R_F + NG \cdot R_I)$  were drawn on top of the open-loop transimpedance plot, the difference between the two would be the loop gain at a given frequency. Eventually,  $Z(s)$  rolls off to equal the denominator of Equation 2 at which point the loop gain has reduced to 1 (and the curves have intersected). This point of equality is where the amplifier's closed-loop frequency response given by Equation 1 will start to roll off, and is exactly analogous to the frequency at which the noise gain equals the open-loop voltage gain for a voltage feedback op amp. The difference here is that the total impedance in the denominator of Equation 2 may be controlled somewhat separately from the desired signal gain (or NG).

The OPA4684 is internally compensated to give a maximally flat frequency response for  $R_F = 800\Omega$  at  $NG = 2$  on  $\pm 5V$  supplies. That optimum value goes to  $1.0k\Omega$  on a single  $+5V$  supply. Normally, with a current-feedback amplifier, it is

possible to adjust the feedback resistor to hold this bandwidth up as the gain is increased. The CFB<sub>PLUS</sub> architecture has reduced the contribution of the inverting input impedance to provide exceptional bandwidth to higher gains without adjusting the feedback resistor value. The Typical Characteristics show the small-signal bandwidth over gain with a fixed feedback resistor.

Putting a closed-loop buffer between the noninverting and inverting inputs does bring some added considerations. Since the voltage at the inverting output node is now the output of a locally closed-loop buffer, parasitic external capacitance on this node can cause frequency response peaking for the transfer function from the noninverting input voltage to the inverting node voltage. While it is always important to keep the inverting node capacitance low for any current-feedback op amp, it is critically important for the OPA4684. External layout capacitance in excess of 2pF will start to peak the frequency response. This peaking can be easily reduced by then increasing the feedback resistor value—but it is preferable, from a noise and dynamic range standpoint, to keep that capacitance low, allowing a close to nominal 800Ω feedback resistor for flat frequency response. Very high parasitic capacitance values on the inverting node (> 5pF) can possibly cause input stage oscillation that cannot be filtered by a feedback element adjustment.

At very high gains, 2nd-order effects in the inverting output impedance cause the overall response to peak up. If desired, it is possible to retain a flat frequency response at higher gains by adjusting the feedback resistor to higher values as the gain is increased. Since the exact value of feedback that will give a flat frequency response depends strongly in inverting and output node parasitic capacitance values, it is best to experiment in the specific board with increasing values until the desired flatness (or pulse response shape) is obtained. In general, increasing  $R_F$  (and adjusting  $R_G$  then to the desired gain) will move towards flattening the response, while decreasing it will extend the bandwidth at the cost of some peaking.

## OUTPUT CURRENT AND VOLTAGE

The OPA4684 provides output voltage and current capabilities that can support the needs of driving doubly-terminated 50Ω lines. For a 100Ω load at the gain of +2, (see Figure 1), the total load is the parallel combination of the 100Ω load and the 1.6kΩ total feedback network impedance. This 94Ω load will require no more than 40mA output current to support the ±3.8V minimum output voltage swing specified for 100Ω loads. This is well under the specified minimum +110mA/–90mA output current specifications over the full temperature range.

The specifications described above, though familiar in the industry, consider voltage and current limits separately. In many applications, it is the voltage • current, or V-I product, which is more relevant to circuit operation. Refer to the “Output Voltage and Current Limitations” curve in the Typical Characteristics. The X- and Y-axes of this graph show the zero-voltage output current limit and the zero-current output voltage limit, respectively. The four quadrants give a more

detailed view of the OPA4684’s output drive capabilities. Superimposing resistor load lines onto the plot shows the available output voltage and current for specific loads.

The minimum specified output voltage and current over temperature are set by worst-case simulations at the cold temperature extreme. Only at cold startup will the output current and voltage decrease to the numbers shown in the Electrical Characteristic tables. As the output transistors deliver power, their junction temperatures will increase, decreasing their  $V_{BE}$ ’s (increasing the available output voltage swing) and increasing their current gains (increasing the available output current). In steady-state operation, the available output voltage and current will always be greater than that shown in the over temperature specifications since the output stage junction temperatures will be higher than the minimum specified operating ambient.

To maintain maximum output stage linearity, no output short-circuit protection is provided. This will not normally be a problem since most applications include a series-matching resistor at the output that will limit the internal power dissipation if the output side of this resistor is shorted to ground. However, shorting the output pin directly to a power-supply pin will, in most cases, destroy the amplifier. If additional short-circuit protection is required, consider a small-series resistor in the power-supply leads. This will, under heavy output loads, reduce the available output voltage swing. A 5Ω series resistor in each power-supply lead will limit the internal power dissipation to less than 1W for an output short-circuit while decreasing the available output voltage swing only 0.25V for up to 50mA desired load currents. This slight drop in available swing is more if multiple channels are driving heavy loads simultaneously. Always place the 0.1μF power-supply decoupling capacitors after these supply current limiting resistors directly on the supply pins.

## DRIVING CAPACITIVE LOADS

One of the most demanding, and yet very common load conditions, for an op amp is capacitive loading. Often, the capacitive load is the input of an ADC—including additional external capacitance which may be recommended to improve ADC linearity. A high-speed, high open-loop gain amplifier like the OPA4684 can be very susceptible to decreased stability and closed-loop response peaking when a capacitive load is placed directly on the output pin. When the amplifier’s open-loop output resistance is considered, this capacitive load introduces an additional pole in the signal path that can decrease the phase margin. Several external solutions to this problem have been suggested. When the primary considerations are frequency response flatness, pulse response fidelity, and/or distortion, the simplest and most effective solution is to isolate the capacitive load from the feedback loop by inserting a series isolation resistor between the amplifier output and the capacitive load. This does not eliminate the pole from the loop response, but rather shifts it and adds a zero at a higher frequency. The additional zero acts to cancel the phase lag from the capacitive load pole, thus increasing the phase margin and improving stability.

The Typical Characteristics show the recommended “ $R_S$  vs  $C_{LOAD}$ ” and the resulting frequency response at the load. The  $1k\Omega$  resistor shown in parallel with the load capacitor is a measurement path and may be omitted. Parasitic capacitive loads greater than  $5pF$  can begin to degrade the performance of the OPA4684. Long PC board traces, unmatched cables, and connections to multiple devices can easily cause this value to be exceeded. Always consider this effect carefully, and add the recommended series resistor as close as possible to the OPA4684 output pin (see Board Layout Guidelines).

## DISTORTION PERFORMANCE

The OPA4684 provides very low distortion in a low-power part. The  $CFB_{PLUS}$  architecture also gives two significant areas of distortion improvement. First, in operating regions where the 2nd-harmonic distortion due to output stage nonlinearities is very low (frequencies  $< 1MHz$ , low output swings into light loads) the linearization at the inverting node provided by the  $CFB_{PLUS}$  design gives 2nd-harmonic distortions that extend into the  $-90dBc$  region. Previous current-feedback amplifiers have been limited to approximately  $-85dBc$  due to the nonlinearities at the inverting input. The second area of distortion improvement comes in a distortion performance that is largely gain independent. To the extent that the distortion at a particular output power is output stage dependent, 3rd-harmonics particularly, and to a lesser extent 2nd-harmonic distortion, is constant as the gain is increased. This is due to the constant loop gain versus signal gain provided by the  $CFB_{PLUS}$  design. As shown in the Typical Characteristic curves, while the 3rd-harmonic is constant with gain, the 2nd-harmonic degrades at higher gains. This is largely due to board parasitic issues. Slightly imbalanced load return currents will couple into the gain resistor to cause a portion of the 2nd-harmonic distortion. At high gains, this imbalance has more gain to the output giving reduced 2nd-harmonic distortion. Differential stages using two of the channels together can reduce this 2nd-harmonic issue enormously getting back to an essentially gain independent distortion.

Relative to alternative amplifiers with  $< 2mA/ch$  supply current, the OPA4684 holds much lower distortion at higher frequencies ( $> 5MHz$ ) and to higher gains. Generally, until the fundamental signal reaches very high frequency or power levels, the 2nd-harmonic will dominate the distortion with a lower 3rd-harmonic component. Focusing then on the 2nd-harmonic, increasing the load impedance improves distortion directly. Remember that the total load includes the feedback network—in the noninverting configuration (see Figure 1) this is the sum of  $R_F + R_G$ , while in the inverting configuration it is just  $R_F$ . Also, providing an additional supply decoupling capacitor ( $0.1\mu F$ ) between the supply pins (for bipolar operation) improves the 2nd-order distortion slightly (3dB to 6dB).

In most op amps, increasing the output voltage swing increases harmonic distortion directly. A low-power part like the OPA4684 includes quiescent boost circuits to provide the large-signal bandwidth in the Electrical Characteristics. These act to increase the bias in a very linear fashion only when

high slew rate or output power are required. This also acts to actually reduce the distortion slightly at higher output power levels. The Typical Characteristic curves show the 2nd-harmonic holding constant from  $500mVp-p$  to  $5Vp-p$  outputs while the 3rd-harmonics actually decrease with increasing output power.

The OPA4684 has an extremely low 3rd-order harmonic distortion, particularly for light loads and at lower frequencies. This also gives low 2-tone, 3rd-order intermodulation distortion as shown in the Typical Characteristic curves. Since the OPA4684 includes internal power boost circuits to retain good full-power performance at high frequencies and outputs, it does not show a classical 2-tone, 3rd-order intermodulation intercept characteristic. Instead, it holds relatively low and constant 3rd-order intermodulation spurious levels over power. The Typical Characteristic curves show this spurious level as a dBc below the carrier at fixed center frequencies swept over single-tone power at a matched  $50\Omega$  load. These spurious levels drop significantly ( $> 12dB$ ) for lighter loads than the  $100\Omega$  used in the “2-Tone, 3rd-Order Intermodulation Distortion” curve. Converter inputs for instance will see  $< -82dBc$  3rd-order spurious to  $10MHz$  for full-scale inputs. For even lower 3rd-order intermodulation distortion to much higher frequencies, consider the OPA2691 dual or OPA691 and OPA685 single-channel current-feedback amplifiers.

## NOISE PERFORMANCE

Wideband current-feedback op amps generally have a higher output noise than comparable voltage-feedback op amps. The OPA4684 offers an excellent balance between voltage and current noise terms to achieve low output noise in a low-power amplifier. The inverting current noise ( $17pA/\sqrt{Hz}$ ) is comparable to most other current-feedback op amps while the input voltage noise ( $3.7nV/\sqrt{Hz}$ ) is lower than any unity-gain stable, comparable slew rate, voltage-feedback op amp. This low input voltage noise was achieved at the price of higher noninverting input current noise ( $9.4pA/\sqrt{Hz}$ ). As long as the AC source impedance looking out of the noninverting node is less than  $200\Omega$ , this current noise will not contribute significantly to the total output noise. The op amp input voltage noise and the two input current noise terms combine to give low output noise under a wide variety of operating conditions. Figure 15 shows the op amp noise analysis model with all the noise terms included. In this model, all noise terms are taken to be noise voltage or current density

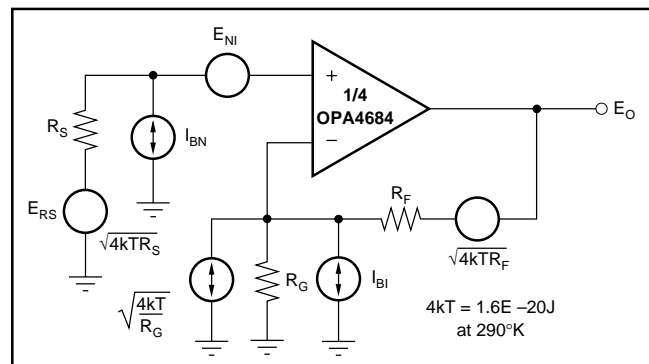

FIGURE 15. Op Amp Noise Analysis Model.

terms in either  $nV/\sqrt{Hz}$  or  $pA/\sqrt{Hz}$ .

The total output spot noise voltage can be computed as the square root of the sum of all squared output noise voltage contributors. Equation 3 shows the general form for the output noise voltage using the terms presented in Figure 12.

$$E_O = \sqrt{\left(E_{NI}^2 + (I_{BN}R_S)^2 + 4kTR_S\right)G_N^2 + (I_{BI}R_F)^2 + 4kTR_F G_N} \quad (3)$$

Dividing this expression by the noise gain ( $G_N = (1+R_F/R_G)$ ) will give the equivalent input referred spot noise voltage at the noninverting input, as shown in Equation 4.

$$E_N = \sqrt{E_{NI}^2 + (I_{BN}R_S)^2 + 4kTR_S + \left(\frac{I_{BI}R_F}{G_N}\right)^2 + \frac{4kTR_F}{G_N}} \quad (4)$$

Evaluating these two equations for the OPA4684 circuit and component values presented in Figure 1 will give a total output spot noise voltage of  $16.3nV/\sqrt{Hz}$  and a total equivalent input spot noise voltage of  $8.1nV/\sqrt{Hz}$ . This total input referred spot noise voltage is higher than the  $3.7nV/\sqrt{Hz}$  specification for the op amp voltage noise alone. This reflects the noise added to the output by the inverting current noise times the feedback resistor. As the gain is increased, this fixed output noise power term contributes less to the total output noise and the total input referred voltage noise given by Equation 3 will approach just the  $3.7nV/\sqrt{Hz}$  of the op amp itself. For example, going to a gain of +20 in the circuit of Figure 1, adjusting only the gain resistor to  $42.1\Omega$ , will give a total input referred noise of  $3.9nV/\sqrt{Hz}$ . A more complete description of op amp noise analysis can be found in the Texas Instruments application note, AB-103, "Noise Analysis for High Speed Op Amps" (SBOA066), located at [www.ti.com](http://www.ti.com).

## DC ACCURACY AND OFFSET CONTROL

A current-feedback op amp like the OPA4684 provides exceptional bandwidth in high gains, giving fast pulse settling but only moderate DC accuracy. The Electrical Characteristics show an input offset voltage comparable to high slew rate voltage-feedback amplifiers. However, the two input bias currents are somewhat higher and are unmatched. Whereas bias current cancellation techniques are very effective with most voltage-feedback op amps, they do not generally reduce the output DC offset for wideband current-feedback op amps. Since the two input bias currents are unrelated in both magnitude and polarity, matching the source impedance looking out of each input to reduce their

error contribution to the output is ineffective. Evaluating the configuration of Figure 1, using worst-case +25°C input offset voltage and the two input bias currents, gives a worst-case output offset range equal to:

$$\begin{aligned} & \pm(NG \cdot V_{OS(MAX)} + (I_{BN} \cdot R_S/2 \cdot NG) \pm (I_{BI} \cdot R_F)) \\ & \text{where } NG = \text{noninverting signal gain} \\ & = \pm(2 \cdot 4.0mV) \pm (13\mu A \cdot 25\Omega \cdot 2) \pm (800\Omega \cdot 17\mu A) \\ & = \pm 8mV + 0.65mV \pm 13.6mV \\ & = \pm 22.3mV \end{aligned}$$

While the last term, the inverting bias current error, is dominant in this low-gain circuit, the input offset voltage will become the dominant DC error term as the gain exceeds  $5V/V$ . Where improved DC precision is required in a high-speed amplifier, consider the OPA656 single and OPA2822 dual voltage-feedback amplifiers.

## THERMAL ANALYSIS

The OPA4684 will not require external heatsinking or airflow most applications. Maximum desired junction temperature will set the maximum allowed internal power dissipation as described below. In no case should the maximum junction temperature be allowed to exceed  $175^\circ C$ .

Operating junction temperature ( $T_J$ ) is given by  $T_A + P_D \cdot \theta_{JA}$ . The total internal power dissipation ( $P_D$ ) is the sum of quiescent power ( $P_{DQ}$ ) and additional power dissipated in the output stage ( $P_{DL}$ ) to deliver load power. Quiescent power is simply the specified no-load supply current times the total supply voltage across the part.  $P_{DL}$  will depend on the required output signal and load but would, for a grounded resistive load, be at a maximum when the output is fixed at a voltage equal to  $1/2$  either supply voltage (for equal bipolar supplies). Under this condition  $P_{DL} = V_S^2/(4 \cdot R_L)$  where  $R_L$  includes feedback network loading.

Note that it is the power in the output stage and not into the load that determines internal power dissipation.

As an absolute worst-case example, compute the maximum  $T_J$  using an OPA4684IPW (TSSOP-14 package) in the circuit of Figure 1 operating at the maximum specified ambient temperature of  $+85^\circ C$  with all channels driving a grounded  $100\Omega$  load to  $2.5V_{DC}$ .

$$P_D = 10V \cdot 7.8mA + 4 \cdot (5^2 / (4 \cdot (100\Omega \parallel 1.6k\Omega))) = 144mW$$

Maximum  $T_J = +85^\circ C + (0.144W \cdot 110^\circ C/W) = 101^\circ C$ .

This maximum operating junction temperature is well below most system level targets. Most applications will be lower than this since an absolute worst-case output stage power was assumed in this calculation with all 4 channels running maximum output power simultaneously.

## BOARD LAYOUT GUIDELINES

Achieving optimum performance with a high-frequency amplifier like the OPA4684 requires careful attention to board layout parasitics and external component types. Recommendations that will optimize performance include:

- a) **Minimize parasitic capacitance** to any AC ground for all of the signal I/O pins. Parasitic capacitance on the output and inverting input pins can cause instability; on the noninverting input, it can react with the source impedance to cause unintentional bandlimiting. To reduce unwanted capacitance, a window around the signal I/O pins should be opened in all of the ground and power planes around those pins. Otherwise, ground and power planes should be unbroken elsewhere on the board.
- b) **Minimize the distance** ( $< 0.25"$ ) from the power-supply pins to high-frequency  $0.1\mu\text{F}$  decoupling capacitors. At the device pins, the ground and power-plane layout should not be in close proximity to the signal I/O pins. Avoid narrow power and ground traces to minimize inductance between the pins and the decoupling capacitors. The power-supply connections should always be decoupled with these capacitors. An optional supply decoupling capacitor ( $0.01\mu\text{F}$ ) across the two power supplies (for bipolar operation) will improve 2nd-harmonic distortion performance. Larger ( $2.2\mu\text{F}$  to  $6.8\mu\text{F}$ ) decoupling capacitors, effective at lower frequencies, should also be used on the main supply pins. These may be placed somewhat farther from the device and may be shared among several devices in the same area of the PC board.
- c) **Careful selection and placement of external components will preserve the high-frequency performance of the OPA4684.** Resistors should be a very low reactance type. Surface-mount resistors work best and allow a tighter overall layout. Metal film and carbon composition axially-leaded resistors can also provide good high-frequency performance. Again, keep their leads and PC-board trace length as short as possible. Never use wirewound type resistors in a high-frequency application. Since the output pin and inverting input pin are the most sensitive to parasitic capacitance, always position the feedback and series output resistor, if any, as close as possible to the output pin. The quad amplifier pinout allows each output and inverting input to be connected by the feedback element with virtually no trace length. Other network components, such as noninverting input termination resistors, should also be placed close to the package. The frequency response is primarily determined by the feedback resistor value as described previously. Increasing its value will reduce the peaking at higher gains, while decreasing it will give a more peaked frequency response at lower gains. The  $800\Omega$  feedback resistor used in the Typical Characteristics at a gain of +2 on  $\pm 5\text{V}$  supplies is a good starting point for

design. Note that a  $800\Omega$  feedback resistor, rather than a direct short, is required for the unity-gain follower application. A current-feedback op amp requires a feedback resistor even in the unity-gain follower configuration to control stability.

- d) **Connections to other wideband devices** on the board may be made with short direct traces or through onboard transmission lines. For short connections, consider the trace and the input to the next device as a lumped capacitive load. Relatively wide traces (50mils to 100mils) should be used, preferably with ground and power planes opened up around them. Estimate the total capacitive load and set  $R_S$  from the plot of recommended " $R_S$  vs  $C_{\text{LOAD}}$ ". Low parasitic capacitive loads ( $< 5\text{pF}$ ) may not need an  $R_S$  since the OPA4684 is nominally compensated to operate with a  $2\text{pF}$  parasitic load. If a long trace is required, and the 6dB signal loss intrinsic to a doubly-terminated transmission line is acceptable, implement a matched impedance transmission line using microstrip or stripline techniques (consult an ECL design handbook for microstrip and stripline layout techniques). A  $50\Omega$  environment is normally not necessary on board, and in fact a higher impedance environment will improve distortion, see the distortion versus load plots. With a characteristic board trace impedance defined based on board material and trace dimensions, a matching series resistor into the trace from the output of the OPA4684 is used, as well as a terminating shunt resistor at the input of the destination device. Remember also that the terminating impedance will be the parallel combination of the shunt resistor and the input impedance of the destination device; this total effective impedance should be set to match the trace impedance. The high output voltage and current capability of the OPA4684 allows multiple destination devices to be handled as separate transmission lines, each with their own series and shunt terminations. If the 6dB attenuation of a doubly-terminated transmission line is unacceptable, a long trace can be series-terminated at the source end only. Treat the trace as a capacitive load in this case and set the series resistor value as shown in the plot of " $R_S$  vs  $C_{\text{LOAD}}$ ". This will not preserve signal integrity as well as a doubly-terminated line. If the input impedance of the destination device is LOW, there will be some signal attenuation due to the voltage divider formed by the series output into the terminating impedance.
- e) **Socketing a high-speed part like the OPA4684 is not recommended.** The additional lead length and pin-to-pin capacitance introduced by the socket can create an extremely troublesome parasitic network which can make it almost impossible to achieve a smooth, stable frequency response. Best results are obtained by soldering the OPA4684 onto the board.

## INPUT AND ESD PROTECTION

The OPA4684 is built using a very high-speed complementary bipolar process. The internal junction breakdown voltages are relatively low for these very small geometry devices. These breakdowns are reflected in the Absolute Maximum Ratings table where an absolute maximum 13V across the supply pins is reported. All device pins have limited ESD protection using internal diodes to the power supplies, as shown in Figure 16.

These diodes provide moderate protection to input overdrive voltages above the supplies as well. The protection diodes can typically support 30mA continuous current. Where higher currents are possible (e.g. in systems with  $\pm 15V$  supply parts driving into the OPA4684), current limiting series resistors should be added into the two inputs. Keep these resistor values as low as possible since high values degrade both noise performance and frequency response.

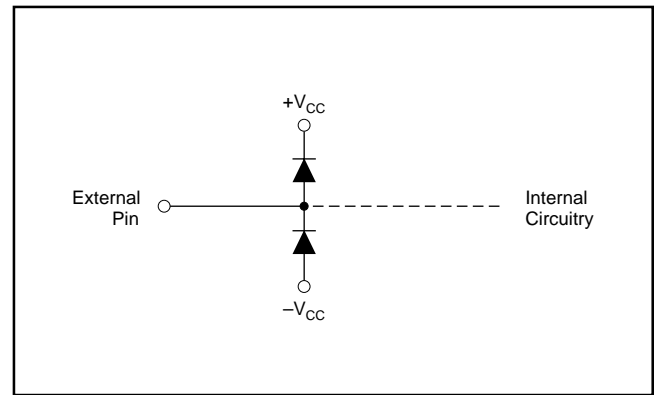

FIGURE 16. Internal ESD Protection.

PACKAGE DRAWINGS

MSOI002B – JANUARY 1995 – REVISED SEPTEMBER 2001

D (R-PDSO-G\*\*)

PLASTIC SMALL-OUTLINE PACKAGE

8 PINS SHOWN

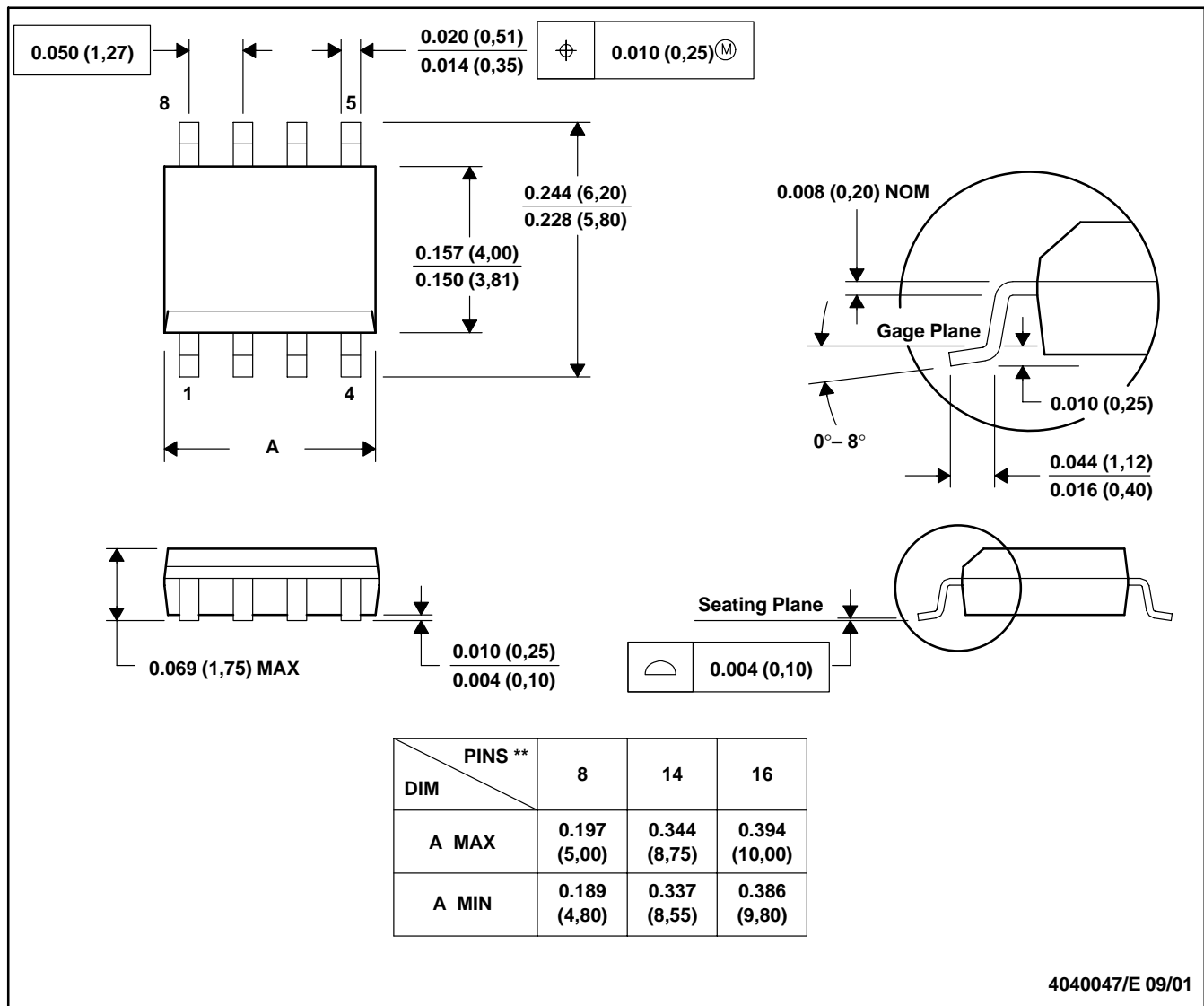

- NOTES: A. All linear dimensions are in inches (millimeters).  
 B. This drawing is subject to change without notice.  
 C. Body dimensions do not include mold flash or protrusion, not to exceed 0.006 (0,15).  
 D. Falls within JEDEC MS-012



PACKAGE DRAWINGS (Cont.)

MTSS001C – JANUARY 1995 – REVISED FEBRUARY 1999

PW (R-PDSO-G\*\*)

PLASTIC SMALL-OUTLINE PACKAGE

14 PINS SHOWN

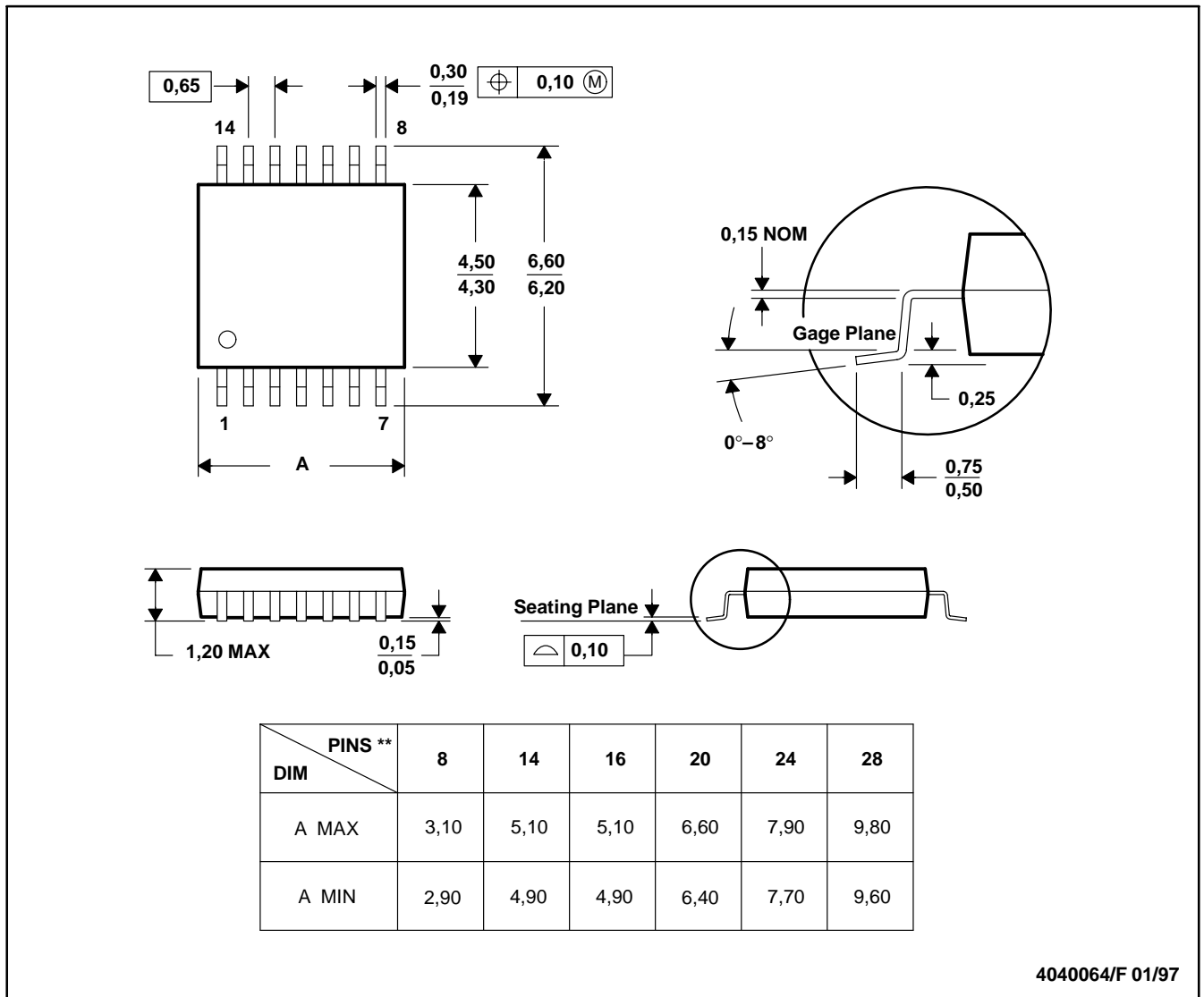

4040064/F 01/97

- NOTES: A. All linear dimensions are in millimeters.  
 B. This drawing is subject to change without notice.  
 C. Body dimensions do not include mold flash or protrusion not to exceed 0,15.  
 D. Falls within JEDEC MO-153

## **IMPORTANT NOTICE**

Texas Instruments Incorporated and its subsidiaries (TI) reserve the right to make corrections, modifications, enhancements, improvements, and other changes to its products and services at any time and to discontinue any product or service without notice. Customers should obtain the latest relevant information before placing orders and should verify that such information is current and complete. All products are sold subject to TI's terms and conditions of sale supplied at the time of order acknowledgment.

TI warrants performance of its hardware products to the specifications applicable at the time of sale in accordance with TI's standard warranty. Testing and other quality control techniques are used to the extent TI deems necessary to support this warranty. Except where mandated by government requirements, testing of all parameters of each product is not necessarily performed.

TI assumes no liability for applications assistance or customer product design. Customers are responsible for their products and applications using TI components. To minimize the risks associated with customer products and applications, customers should provide adequate design and operating safeguards.

TI does not warrant or represent that any license, either express or implied, is granted under any TI patent right, copyright, mask work right, or other TI intellectual property right relating to any combination, machine, or process in which TI products or services are used. Information published by TI regarding third-party products or services does not constitute a license from TI to use such products or services or a warranty or endorsement thereof. Use of such information may require a license from a third party under the patents or other intellectual property of the third party, or a license from TI under the patents or other intellectual property of TI.

Reproduction of information in TI data books or data sheets is permissible only if reproduction is without alteration and is accompanied by all associated warranties, conditions, limitations, and notices. Reproduction of this information with alteration is an unfair and deceptive business practice. TI is not responsible or liable for such altered documentation.

Resale of TI products or services with statements different from or beyond the parameters stated by TI for that product or service voids all express and any implied warranties for the associated TI product or service and is an unfair and deceptive business practice. TI is not responsible or liable for any such statements.

### **Mailing Address:**

Texas Instruments  
Post Office Box 655303  
Dallas, Texas 75265