

INTEGRATED CIRCUITS

DATA SHEET

TDA5634T

9 V UHF mixer/oscillator for TV and VCR tuners

Product specification

1996 Nov 7

Supersedes data of 1995 Mar 21

File under Integrated Circuits, IC02

9 V UHF mixer/oscillator for TV and VCR tuners

TDA5634T

FEATURES

- Balanced mixer with a common base input
- 4-pin oscillator
- Local oscillator buffer output for external prescaler
- SAW filter preamplifier with a low output impedance to drive the SAW filter directly
- Band gap voltage stabilizer for oscillator stability
- External IF filter between the mixer output and the IF amplifier input.

APPLICATION

- UHF tuners for TV and VCR
- One band tuners.

GENERAL DESCRIPTION

The TDA5634T is an integrated circuit that performs the UHF mixer/oscillator functions in TV and VCR tuners. This low-power mixer/oscillator requires a power supply of 9 V and is available in a very small package.

The device gives the designer the capability to design an economical and physically small tuner.

The tuner development time can be drastically reduced by using this device.

The frequency band is determined by the external tank circuit. It can be adapted to various standards.

QUICK REFERENCE DATA

SYMBOL	PARAMETER	CONDITIONS	MIN.	TYP.	MAX.	UNIT
V_P	supply voltage		–	9.0	–	V
I_P	supply current		–	35	–	mA
f_{RF}	RF frequency	RF input; note 1	430	–	860	MHz
G_V	voltage gain		–	36	–	dB
NF	noise figure	not corrected for image	–	9	–	dB
V_o	output voltage causing 1% cross modulation in channel		–	121	–	dB μ V

Note

1. The limits are related to the tank circuits used in Fig.7 and the intermediate frequency. Frequency bands may be adjusted by the choice of external components.

ORDERING INFORMATION

TYPE NUMBER	PACKAGE		
	NAME	DESCRIPTION	VERSION
TDA5634T	SO16	plastic small outline package; 16 leads; body width 3.9 mm	SOT109-1

9 V UHF mixer/oscillator for TV and VCR tuners

TDA5634T

BLOCK DIAGRAM

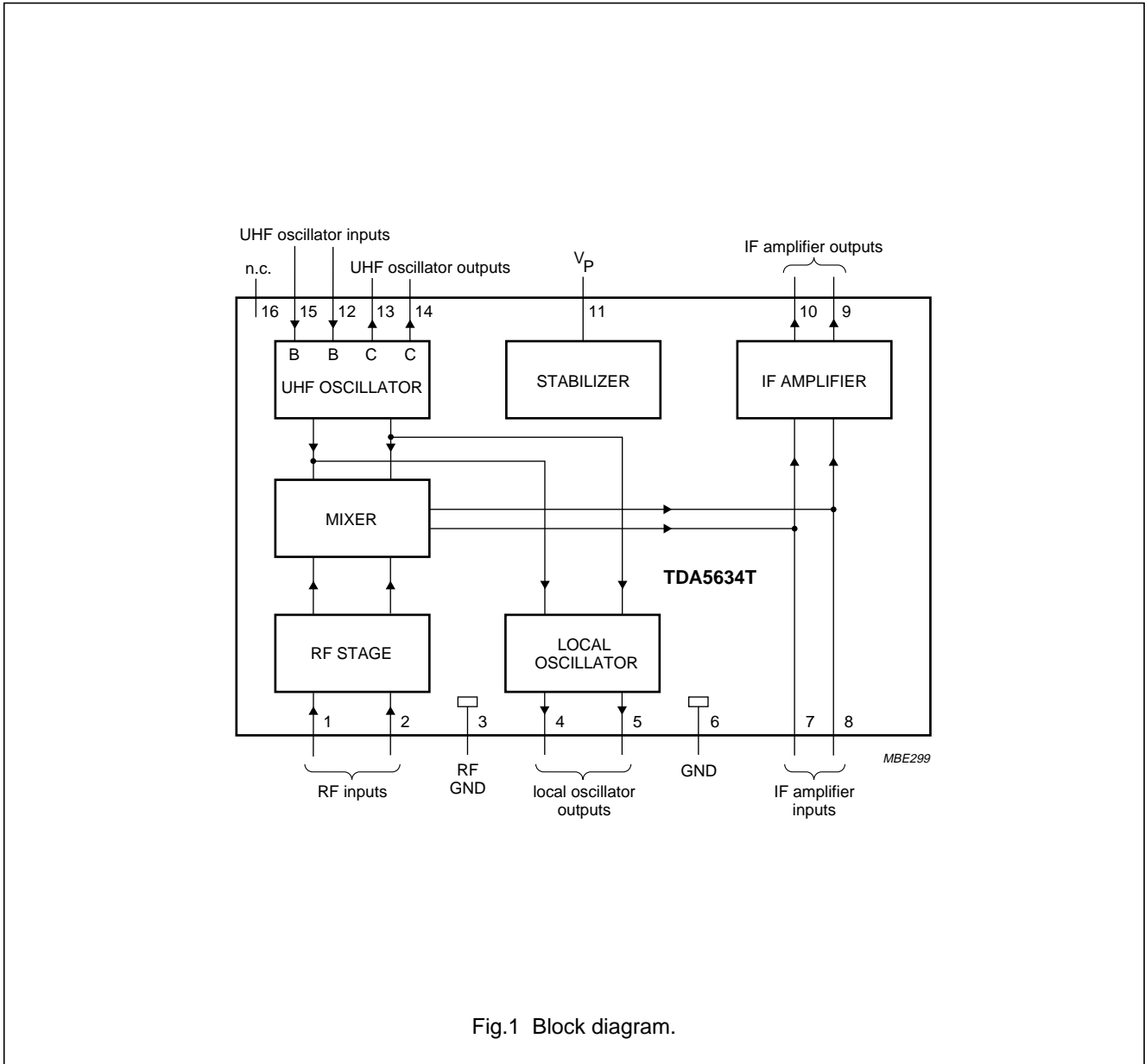

Fig.1 Block diagram.

9 V UHF mixer/oscillator for TV and VCR tuners

TDA5634T

PINNING

SYMBOL	PIN	DESCRIPTION
CIN1	1	band C input 1
CIN2	2	band C input 2
RFGND	3	ground for RF inputs
LOOUT1	4	local oscillator amplifier output 1
LOOUT2	5	local oscillator amplifier output 2
GND	6	ground (0 V)
IFIN1	7	IF amplifier input 1
IFIN2	8	IF amplifier input 2
IFOUT1	9	IF amplifier output 1
IFOUT2	10	IF amplifier output 2
V _P	11	supply voltage
COSCIB1	12	UHF oscillator input base 1
COSCOC1	13	UHF oscillator output collector 1
COSCOC2	14	UHF oscillator output collector 2
COSCIB2	15	UHF oscillator input base 2
n.c.	16	not connected

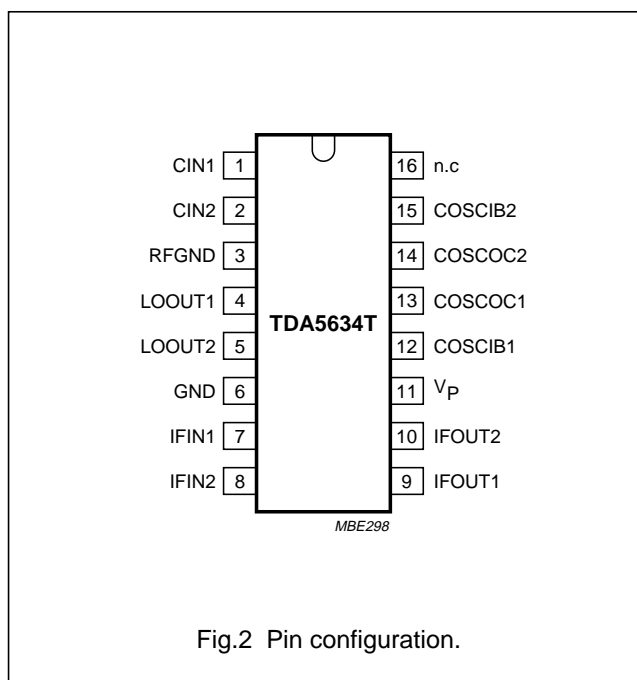

LIMITING VALUES

In accordance with the Absolute Maximum Rating System (IEC 134).

SYMBOL	PARAMETER	MIN.	MAX.	UNIT
V _P	supply voltage	-0.3	+10.5	V
I _O	output current of each pin referenced to ground	-	-10	mA
t _{sc}	maximum short-circuit time (all pins)	-	10	s
T _{stg}	IC storage temperature	-55	+150	°C
T _{amb}	operating ambient temperature	-10	+80	°C
T _j	junction temperature	-	+150	°C

HANDLING

Human body model: the IC withstands 2000 V in accordance with the "UZW-BO/FQ-A302", specification equivalent to the "MIL-STD-883C category B" (2000 V);

R = 1500 Ω, C = 100 pF.

Machine model: the IC withstands 200 V except pin 11 (175 V) in accordance with the "UZW-BO/FQ-B302", specification (date of issue: Nov 6th, 1990);

R = 0 Ω, C = 200 pF.

THERMAL CHARACTERISTICS

SYMBOL	PARAMETER	VALUE	UNIT
R _{th j-a}	thermal resistance from junction to ambient in free air	120	K/W

9 V UHF mixer/oscillator for TV and VCR tuners

TDA5634T

CHARACTERISTICS

$V_P = 9\text{ V}$; $T_{\text{amb}} = 25\text{ °C}$; measured in circuit of Fig.7; unless otherwise specified.

SYMBOL	PARAMETER	CONDITIONS	MIN.	TYP.	MAX.	UNIT
Supply						
V_P	supply voltage		8.1	9.0	9.9	V
I_P	supply current	$V_P = 8.1\text{ to }9.9\text{ V}$; $T_{\text{amb}} = -10\text{ to }+80\text{ °C}$	–	35	45	mA
Mixer (including IF amplifier)						
f_{RF}	RF frequency	note 1	430	–	860	MHz
G_v	voltage gain	$f_{\text{RF}} = 430\text{ MHz}$; see Fig.3; note 2	33	36	39	dB
		$f_{\text{RF}} = 860\text{ MHz}$; see Fig.3; note 2	33	36	39	dB
NF	noise figure (not corrected for image)	$f_{\text{RF}} = 430\text{ MHz}$; see Fig.4	–	9	11	dB
		$f_{\text{RF}} = 860\text{ MHz}$; see Fig.4	–	9	11	dB
V_o	output voltage causing 1% cross modulation in channel	$f_{\text{RF}} = 430\text{ MHz}$; see Fig.5	115	118	–	dB μ V
		$f_{\text{RF}} = 860\text{ MHz}$; see Fig.5	118	121	–	dB μ V
V_i	input voltage causing 10 kHz pulling in channel	$f_{\text{RF}} = 860\text{ MHz}$; note 3	–	87	–	dB μ V
	input voltage causing $N + 5 - 1\text{ MHz}$ pulling	$f_{\text{RF}} = 820\text{ MHz}$; see Fig.6	65	72	–	dB μ V
Z_i	input impedance ($R_S + jL_S\omega$)	R_S at $f_{\text{RF}} = 430\text{ MHz}$; see Fig.8; note 4	–	28	–	Ω
		R_S at $f_{\text{RF}} = 860\text{ MHz}$; see Fig.8; note 4	–	33	–	Ω
		L_S at $f_{\text{RF}} = 430\text{ to }860\text{ MHz}$; see Fig.8; note 4	–	8	–	nH
IF amplifier						
S_{11}	input reflection coefficient	magnitude; see Fig.10; note 4	–	–0.6	–	dB
		phase; see Fig.10; note 4	–	–2.5	–	deg
S_{12}	reverse transmission coefficient	magnitude; see Fig.11; note 4	–	–56	–	dB
		phase; see Fig.11; note 4	–	30	–	deg
S_{21}	forward transmission coefficient	magnitude; note 4	–	–9.5	–	dB
		phase; note 4	–	165	–	deg
S_{22}	output reflection coefficient	magnitude; see Fig.11; note 4	–	–7	–	dB
		phase; see Fig.11; note 4	–	6	–	deg
Z_o	output impedance ($R_S + jL_S\omega$)	R_S ; see Fig.11; note 4	–	100	–	Ω
		L_S ; see Fig.11; note 4	–	32	–	nH
Y_i	input admittance ($G_P + jC_P\omega$)	G_P ; see Fig.10; note 4	–	0.8	–	mS
		C_P ; see Fig.10; note 4	–	2.5	–	pF

9 V UHF mixer/oscillator for TV and VCR tuners

TDA5634T

SYMBOL	PARAMETER	CONDITIONS	MIN.	TYP.	MAX.	UNIT
LO output; $R_L = 100 \Omega$						
Y_o	output admittance ($G_P + jC_{P\omega}$)	$f_{OSC} = 470 \text{ MHz}$; see Fig.9; note 4	–	3	–	mS
			–	0.5	–	pF
		$f_{OSC} = 900 \text{ MHz}$; see Fig.9; note 4	–	3.5	–	mS
			–	0.5	–	pF
V_o	output voltage	$R_L = 50 \Omega$; $V_P = 8.1 \text{ to } 9.9 \text{ V}$; $T_{amb} = -10 \text{ to } +80 \text{ }^\circ\text{C}$	83	91	100	$\text{dB}\mu\text{V}$
SRF	spurious signal on LO output with respect to LO output signal	$R_L = 50 \Omega$; note 5	–	–	–10	dBc
SHD	LO signal harmonics with respect to LO signal	$R_L = 50 \Omega$	–	–	–10	dBc
Band C oscillator						
f_{osc}	oscillator frequency	$V_t = 0.45 \text{ to } 28 \text{ V}$; $V_P = 8.1 \text{ to } 9.9 \text{ V}$; $T_{amb} = -10 \text{ to } +80 \text{ }^\circ\text{C}$; note 6	470	–	900	MHz
f_{shift}	frequency shift	$\Delta V_P = 10\%$; note 7	–	–	400	kHz
f_{drift}	frequency drift	$\Delta T = 25 \text{ }^\circ\text{C}$ without compensation; NP0 capacitors; note 8	–	–	2.5	MHz
		$\Delta T = 25 \text{ }^\circ\text{C}$ with compensation; note 9	–	–	800	kHz
		5 s to 15 minutes after switch on; without compensation; note 10	–	–	600	kHz

Notes

- The RF frequency range is defined by the oscillator frequency range and the intermediate frequency.
- The gain is defined as the transducer gain (measured in Fig.7) plus the voltage transformation ratio of L3 to L2 (10 : 2, 15.4 dB including transformer loss).
- The input level causing 10 kHz frequency detuning at the LO output; $f_{OSC} = f_{RF} + 33.4 \text{ MHz}$.
- All S-parameters are referred to a 50Ω system.
- Measured with RF input voltage of $97 \text{ dB}\mu\text{V}$ at $430 \text{ MHz} < f_{RF} < 860 \text{ MHz}$.
- Limits are related to the tank circuits used in Fig.7. Frequency bands may be adjusted by the choice of external components.
- The frequency shift is defined as the change in oscillator frequency when the supply voltage varies from $V_P = 9 \text{ to } 8.1 \text{ V}$ or from $V_P = 9 \text{ to } 9.9 \text{ V}$.
- The frequency drift is defined as the change in oscillator frequency when the ambient temperature varies from $T_{amb} = 25 \text{ }^\circ\text{C}$ to $0 \text{ }^\circ\text{C}$ or from $T_{amb} = 25 \text{ }^\circ\text{C}$ to $50 \text{ }^\circ\text{C}$. Without compensation, the capacitors C11 to C15 are NP0.
- The frequency drift is defined as the change in oscillator frequency when the ambient temperature varies from $T_{amb} = 25 \text{ }^\circ\text{C}$ to $0 \text{ }^\circ\text{C}$ or from $T_{amb} = 25 \text{ }^\circ\text{C}$ to $50 \text{ }^\circ\text{C}$. With compensation, the capacitors C11 to C14 are N750 and C15 is N470.
- Switch on drift is defined as the change in oscillator frequency between 5 s and 15 min after switch on.

9 V UHF mixer/oscillator for TV and VCR tuners

TDA5634T

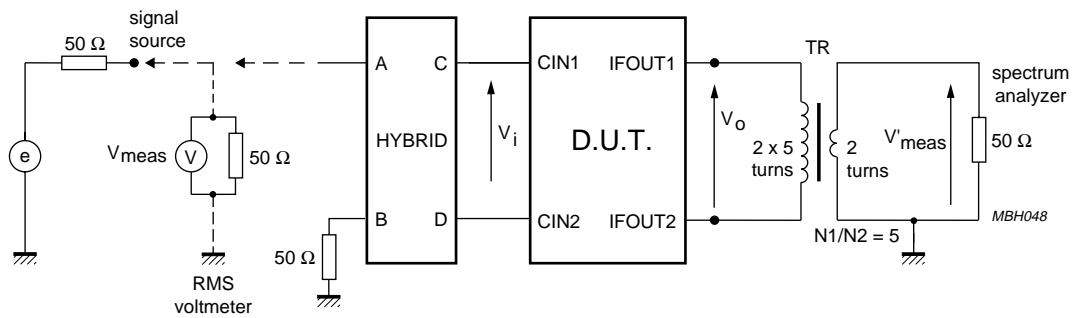

Loss of the hybrid: 1 dB.

$V_i = V_{meas} - \text{loss of the hybrid.}$

$V_o = V'_{meas} + 15.4 \text{ dB (transformer ratio } N1/N2 = 5 \text{ and transformer loss).}$

$G_v = 20 \log \frac{V_o}{V_i} = 20 \log \frac{V'_{meas}}{V_{meas}} + 15.4 \text{ dB} + \text{loss of the hybrid.}$

Fig.3 Gain measurement in band C.

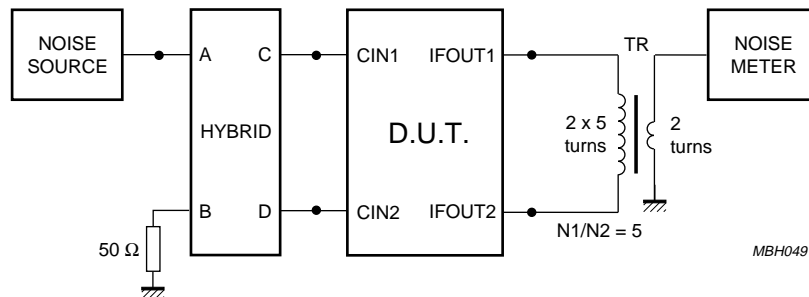

Loss of the hybrid: 1 dB.

$NF = NF_{meas} - \text{loss of the hybrid.}$

Fig.4 Noise figure measurement in band C.

9 V UHF mixer/oscillator for TV and VCR tuners

TDA5634T

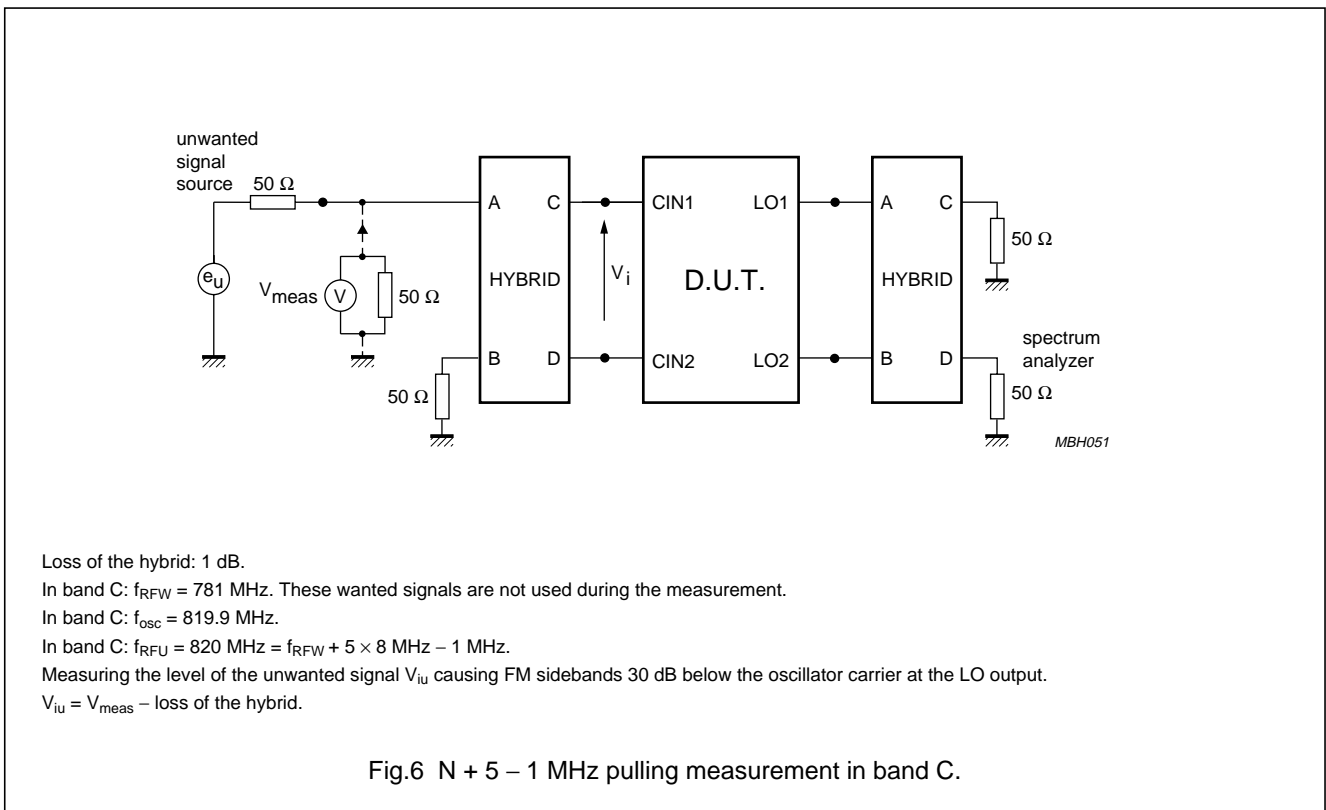
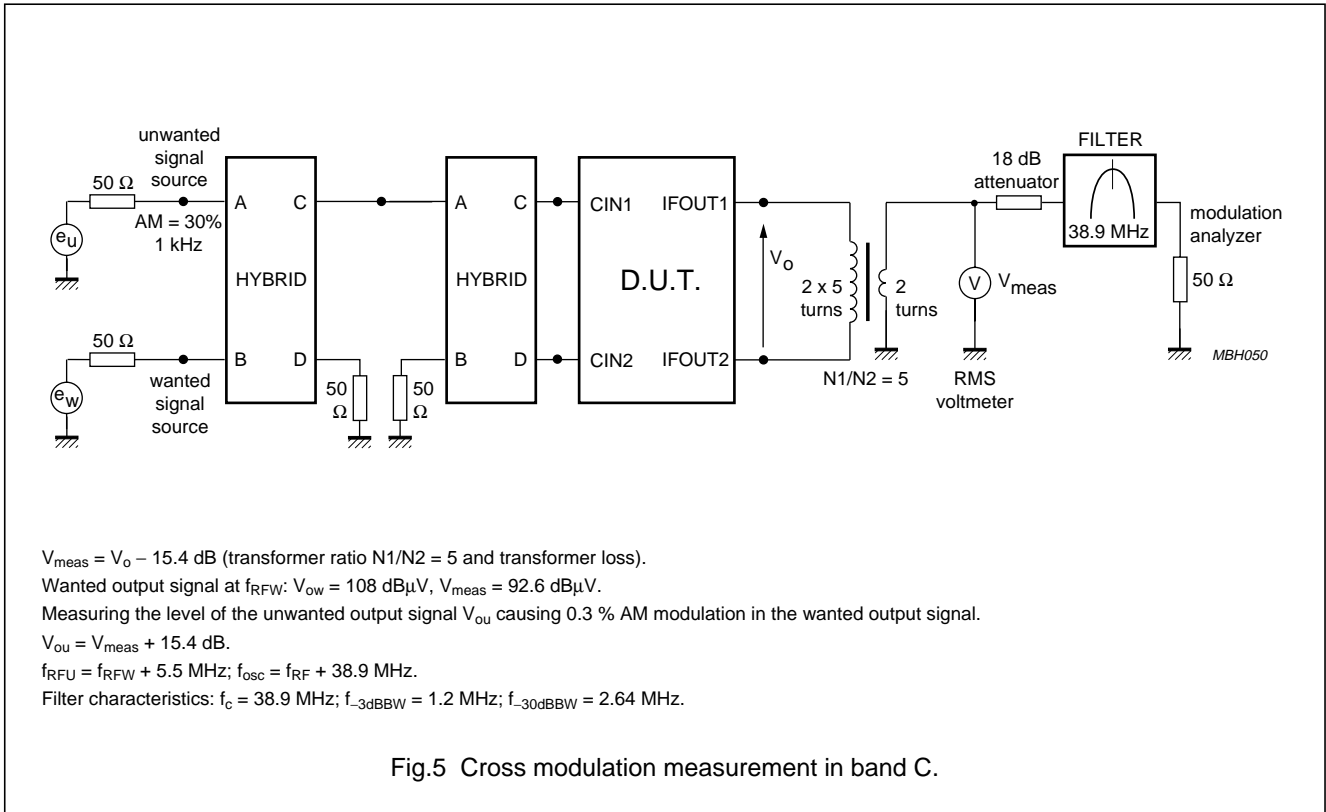

9 V UHF mixer/oscillator for TV and VCR tuners

TDA5634T

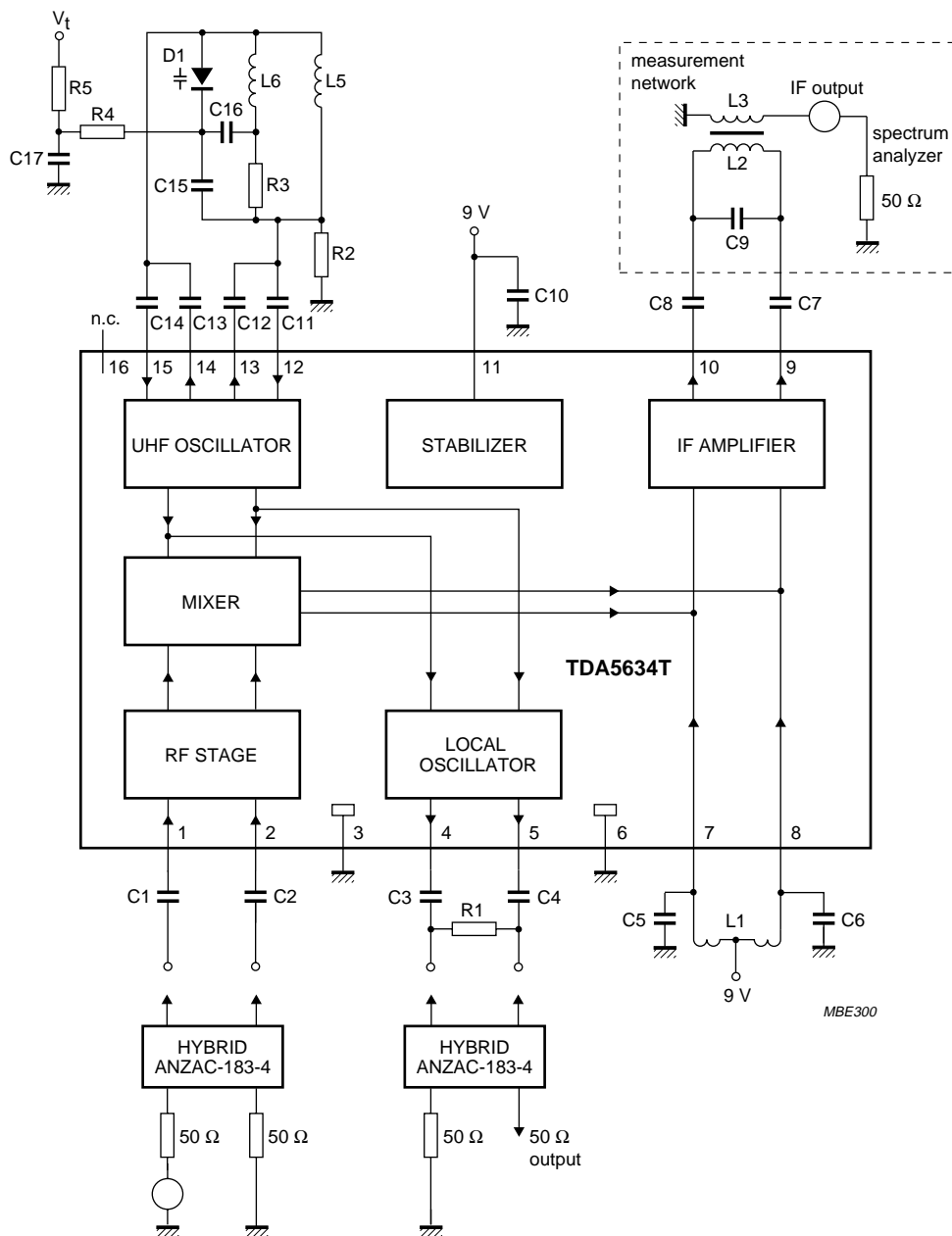

L2, L3 and C9 are only required for measurement purposes; they are not used in a tuner.

Fig.7 Measurement circuit.

9 V UHF mixer/oscillator for TV and VCR tuners

TDA5634T

Component values for measurement circuit

Table 1 Capacitors
(all SMD and NP0 except C11 to C15)

COMPONENT	VALUE
C1	1 nF
C2	1 nF
C3	1 nF
C4	1 nF
C5	18 pF
C6	18 pF
C7	1 nF
C8	1 nF
C9	18 pF
C10	22 nF
C11	1 pF (N750)
C12	1 pF (N750)
C13	1 pF (N750)
C14	1 pF (N750)
C15	6 pF (N470)
C16	100 pF
C17	1 μ F (40 V electrolytic capacitor)

Table 2 Resistors (all SMD)

COMPONENT	VALUE
R1	100 Ω
R2	22 k Ω
R3	2.2 k Ω
R4	22 k Ω
R5	47 k Ω

Table 3 Diodes and IC

COMPONENT	VALUE
D1	BB215
IC	TDA5634T

Table 4 Coils (wire size 0.4 mm)

COMPONENT	VALUE
L5	2.5 turns; diameter 3 mm
L6	2.5 turns; diameter 2.5 mm

Table 5 Transformers; note 1

COMPONENT	VALUE
L1	2 \times 6 turns
L2	2 \times 5 turns
L3	2 turns

Note

- Coil type: TOKO 7kN; material: 113kN; screw core 03-0093; pot core 04-0026.

9 V UHF mixer/oscillator for TV and VCR
tuners

TDA5634T

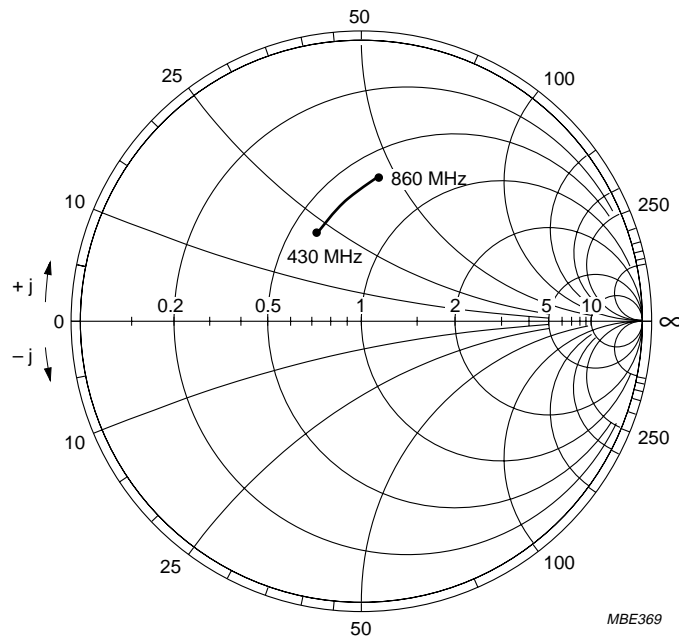

Fig.8 Input impedance (S_{11}) of the mixer input (430 to 860 MHz) (Z chart).

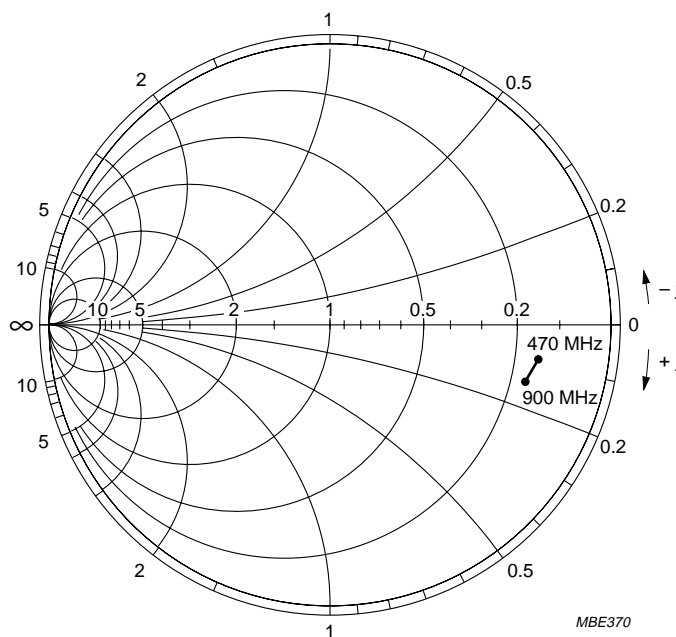

Fig.9 Output admittance (S_{22}) of the LO output (470 to 900 MHz) (Y chart).

9 V UHF mixer/oscillator for TV and VCR
tuners

TDA5634T

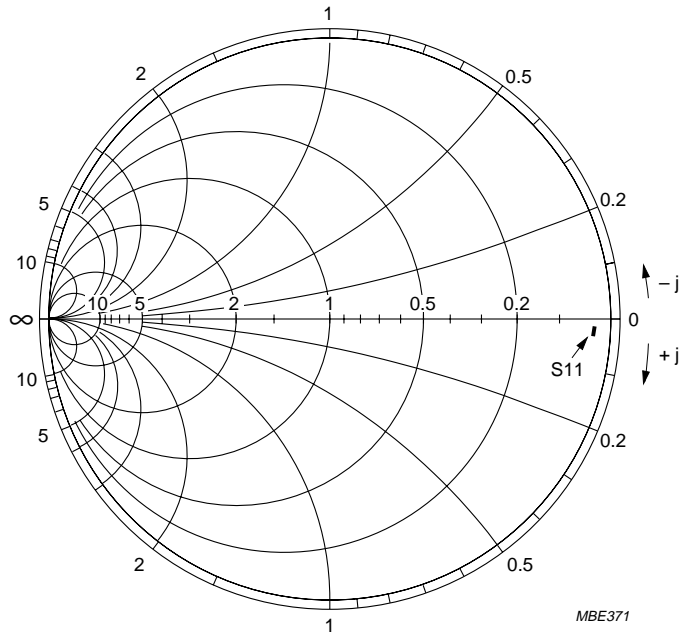

Fig.10 Input admittance (S_{11}) of the IF amplifier (25 to 45 MHz) (Y chart).

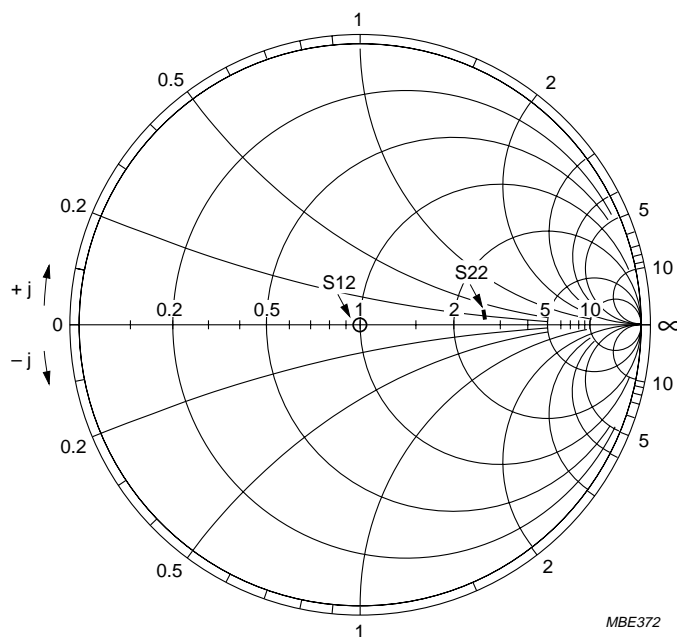

Fig.11 Reverse transmission and output reflection coefficient (S_{12} and S_{22}) of the IF amplifier (25 to 45 MHz) (Z chart).

9 V UHF mixer/oscillator for TV and VCR tuners

TDA5634T

INTERNAL PIN CONFIGURATION

SYMBOL	PIN	DESCRIPTION	AVERAGE DC VOLTAGE ⁽¹⁾ IN (V)
	TDA5634T		BAND C
CIN1	1		2.2
CIN2	2		2.2
RFGND	3		0.0
LOOUT1	4		7.3
LOOUT2	5		7.3
GND	6		0
IFIN1	7		9.0
IFIN2	8		9.0
IFOUT1	9		3.8
IFOUT2	10		3.8

9 V UHF mixer/oscillator for TV and VCR tuners

TDA5634T

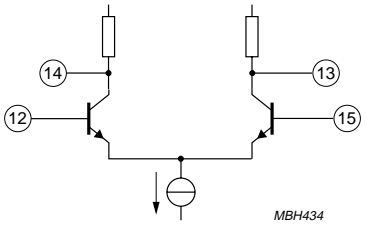
SYMBOL	PIN	DESCRIPTION	AVERAGE DC VOLTAGE ⁽¹⁾ IN (V)
	TDA5634T		BAND C
V _P	11	supply voltage	9.0
COSCIB1	12		2.3
COSCOC1	13		4.4
COSCOC2	14		4.4
COSCIB2	15		2.3
n. c.	16		not connected

Notes

1. Average DC voltage measured in circuit of Fig.7.
2. N.R. = Not Relevant.

9 V UHF mixer/oscillator for TV and VCR tuners

TDA5634T

PACKAGE OUTLINE

SO16: plastic small outline package; 16 leads; body width 3.9 mm

SOT109-1

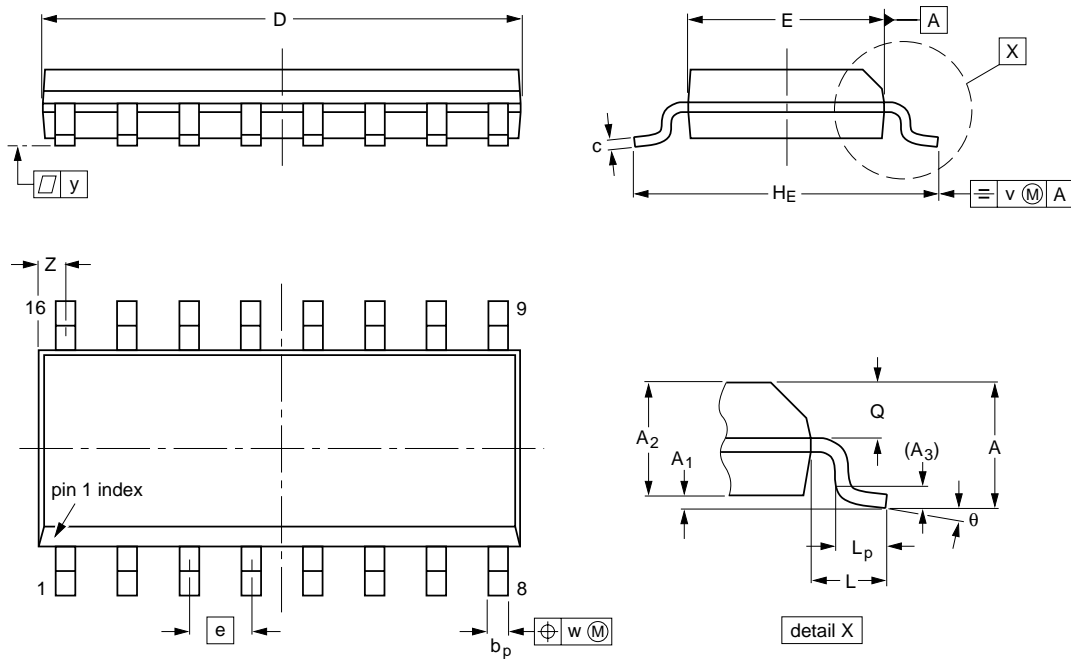

DIMENSIONS (inch dimensions are derived from the original mm dimensions)

UNIT	A max.	A ₁	A ₂	A ₃	b _p	c	D ⁽¹⁾	E ⁽¹⁾	e	H _E	L	L _p	Q	v	w	y	z ⁽¹⁾	θ
mm	1.75	0.25 0.10	1.45 1.25	0.25	0.49 0.36	0.25 0.19	10.0 9.8	4.0 3.8	1.27	6.2 5.8	1.05	1.0 0.4	0.7 0.6	0.25	0.25	0.1	0.7 0.3	8° 0°
inches	0.069	0.010 0.004	0.057 0.049	0.01	0.019 0.014	0.0100 0.0075	0.39 0.38	0.16 0.15	0.050	0.244 0.228	0.041	0.039 0.016	0.028 0.020	0.01	0.01	0.004	0.028 0.012	

Note

1. Plastic or metal protrusions of 0.15 mm maximum per side are not included.

OUTLINE VERSION	REFERENCES				EUROPEAN PROJECTION	ISSUE DATE
	IEC	JEDEC	EIAJ			
SOT109-1	076E07S	MS-012AC				95-01-23 97-05-22

9 V UHF mixer/oscillator for TV and VCR tuners

TDA5634T

SOLDERING

Introduction

There is no soldering method that is ideal for all IC packages. Wave soldering is often preferred when through-hole and surface mounted components are mixed on one printed-circuit board. However, wave soldering is not always suitable for surface mounted ICs, or for printed-circuits with high population densities. In these situations reflow soldering is often used.

This text gives a very brief insight to a complex technology. A more in-depth account of soldering ICs can be found in our *"IC Package Databook"* (order code 9398 652 90011).

Reflow soldering

Reflow soldering techniques are suitable for all SO packages.

Reflow soldering requires solder paste (a suspension of fine solder particles, flux and binding agent) to be applied to the printed-circuit board by screen printing, stencilling or pressure-syringe dispensing before package placement.

Several techniques exist for reflowing; for example, thermal conduction by heated belt. Dwell times vary between 50 and 300 seconds depending on heating method. Typical reflow temperatures range from 215 to 250 °C.

Preheating is necessary to dry the paste and evaporate the binding agent. Preheating duration: 45 minutes at 45 °C.

Wave soldering

Wave soldering techniques can be used for all SO packages if the following conditions are observed:

- A double-wave (a turbulent wave with high upward pressure followed by a smooth laminar wave) soldering technique should be used.
- The longitudinal axis of the package footprint must be parallel to the solder flow.
- The package footprint must incorporate solder thieves at the downstream end.

During placement and before soldering, the package must be fixed with a droplet of adhesive. The adhesive can be applied by screen printing, pin transfer or syringe dispensing. The package can be soldered after the adhesive is cured.

Maximum permissible solder temperature is 260 °C, and maximum duration of package immersion in solder is 10 seconds, if cooled to less than 150 °C within 6 seconds. Typical dwell time is 4 seconds at 250 °C.

A mildly-activated flux will eliminate the need for removal of corrosive residues in most applications.

Repairing soldered joints

Fix the component by first soldering two diagonally-opposite end leads. Use only a low voltage soldering iron (less than 24 V) applied to the flat part of the lead. Contact time must be limited to 10 seconds at up to 300 °C. When using a dedicated tool, all other leads can be soldered in one operation within 2 to 5 seconds between 270 and 320 °C.

9 V UHF mixer/oscillator for TV and VCR tuners

TDA5634T

DEFINITIONS

Data sheet status	
Objective specification	This data sheet contains target or goal specifications for product development.
Preliminary specification	This data sheet contains preliminary data; supplementary data may be published later.
Product specification	This data sheet contains final product specifications.
Limiting values	
Limiting values given are in accordance with the Absolute Maximum Rating System (IEC 134). Stress above one or more of the limiting values may cause permanent damage to the device. These are stress ratings only and operation of the device at these or at any other conditions above those given in the Characteristics sections of the specification is not implied. Exposure to limiting values for extended periods may affect device reliability.	
Application information	
Where application information is given, it is advisory and does not form part of the specification.	

LIFE SUPPORT APPLICATIONS

These products are not designed for use in life support appliances, devices, or systems where malfunction of these products can reasonably be expected to result in personal injury. Philips customers using or selling these products for use in such applications do so at their own risk and agree to fully indemnify Philips for any damages resulting from such improper use or sale.

9 V UHF mixer/oscillator for TV and VCR
tuners

TDA5634T

NOTES

9 V UHF mixer/oscillator for TV and VCR
tuners

TDA5634T

NOTES

Philips Semiconductors – a worldwide company

Argentina: see South America

Australia: 34 Waterloo Road, NORTH RYDE, NSW 2113,
Tel. +61 2 9805 4455, Fax. +61 2 9805 4466

Austria: Computerstr. 6, A-1101 WIEN, P.O. Box 213,
Tel. +43 1 60 101, Fax. +43 1 60 101 1210

Belarus: Hotel Minsk Business Center, Bld. 3, r. 1211, Volodarski Str. 6,
220050 MINSK, Tel. +375 172 200 733, Fax. +375 172 200 773

Belgium: see The Netherlands

Brazil: see South America

Bulgaria: Philips Bulgaria Ltd., Energoproject, 15th floor,
51 James Bourchier Blvd., 1407 SOFIA,
Tel. +359 2 689 211, Fax. +359 2 689 102

Canada: PHILIPS SEMICONDUCTORS/COMPONENTS,
Tel. +1 800 234 7381

China/Hong Kong: 501 Hong Kong Industrial Technology Centre,
72 Tat Chee Avenue, Kowloon Tong, HONG KONG,
Tel. +852 2319 7888, Fax. +852 2319 7700

Colombia: see South America

Czech Republic: see Austria

Denmark: Prags Boulevard 80, PB 1919, DK-2300 COPENHAGEN S,
Tel. +45 32 88 2636, Fax. +45 31 57 1949

Finland: Sinikalliontie 3, FIN-02630 ESPOO,
Tel. +358 9 615800, Fax. +358 9 61580/xxx

France: 4 Rue du Port-aux-Vins, BP317, 92156 SURESNES Cedex,
Tel. +33 1 40 99 6161, Fax. +33 1 40 99 6427

Germany: Hammerbrookstraße 69, D-20097 HAMBURG,
Tel. +49 40 23 53 60, Fax. +49 40 23 536 300

Greece: No. 15, 25th March Street, GR 17778 TAVROS/ATHENS,
Tel. +30 1 4894 339/239, Fax. +30 1 4814 240

Hungary: see Austria

India: Philips INDIA Ltd, Shivsagar Estate, A Block, Dr. Annie Besant Rd.
Worli, MUMBAI 400 018, Tel. +91 22 4938 541, Fax. +91 22 4938 722

Indonesia: see Singapore

Ireland: Newstead, Clonskeagh, DUBLIN 14,
Tel. +353 1 7640 000, Fax. +353 1 7640 200

Israel: RAPAC Electronics, 7 Kehilat Saloniki St, TEL AVIV 61180,
Tel. +972 3 645 0444, Fax. +972 3 649 1007

Italy: PHILIPS SEMICONDUCTORS, Piazza IV Novembre 3,
20124 MILANO, Tel. +39 2 6752 2531, Fax. +39 2 6752 2557

Japan: Philips Bldg 13-37, Kohnan 2-chome, Minato-ku, TOKYO 108,
Tel. +81 3 3740 5130, Fax. +81 3 3740 5077

Korea: Philips House, 260-199 Itaewon-dong, Yongsan-ku, SEOUL,
Tel. +82 2 709 1412, Fax. +82 2 709 1415

Malaysia: No. 76 Jalan Universiti, 46200 PETALING JAYA, SELANGOR,
Tel. +60 3 750 5214, Fax. +60 3 757 4880

Mexico: 5900 Gateway East, Suite 200, EL PASO, TEXAS 79905,
Tel. +9-5 800 234 7381

Middle East: see Italy

Netherlands: Postbus 90050, 5600 PB EINDHOVEN, Bldg. VB,
Tel. +31 40 27 82785, Fax. +31 40 27 88399

New Zealand: 2 Wagener Place, C.P.O. Box 1041, AUCKLAND,
Tel. +64 9 849 4160, Fax. +64 9 849 7811

Norway: Box 1, Manglerud 0612, OSLO,
Tel. +47 22 74 8000, Fax. +47 22 74 8341

Philippines: Philips Semiconductors Philippines Inc.,
106 Valero St. Salcedo Village, P.O. Box 2108 MCC, MAKATI,
Metro MANILA, Tel. +63 2 816 6380, Fax. +63 2 817 3474

Poland: Ul. Lukiska 10, PL 04-123 WARSZAWA,
Tel. +48 22 612 2831, Fax. +48 22 612 2327

Portugal: see Spain

Romania: see Italy

Russia: Philips Russia, Ul. Usatcheva 35A, 119048 MOSCOW,
Tel. +7 095 247 9145, Fax. +7 095 247 9144

Singapore: Lorong 1, Toa Payoh, SINGAPORE 1231,
Tel. +65 350 2538, Fax. +65 251 6500

Slovakia: see Austria

Slovenia: see Italy

South Africa: S.A. PHILIPS Pty Ltd., 195-215 Main Road Martindale,
2092 JOHANNESBURG, P.O. Box 7430 Johannesburg 2000,
Tel. +27 11 470 5911, Fax. +27 11 470 5494

South America: Rua do Rocio 220, 5th floor, Suite 51,
04552-903 São Paulo, SÃO PAULO - SP, Brazil,
Tel. +55 11 821 2333, Fax. +55 11 829 1849

Spain: Balmes 22, 08007 BARCELONA,
Tel. +34 3 301 6312, Fax. +34 3 301 4107

Sweden: Kottbygatan 7, Akalla, S-16485 STOCKHOLM,
Tel. +46 8 632 2000, Fax. +46 8 632 2745

Switzerland: Allmendstrasse 140, CH-8027 ZÜRICH,
Tel. +41 1 488 2686, Fax. +41 1 481 7730

Taiwan: PHILIPS TAIWAN Ltd., 23-30F, 66,
Chung Hsiao West Road, Sec. 1, P.O. Box 22978,
TAIPEI 100, Tel. +886 2 382 4443, Fax. +886 2 382 4444

Thailand: PHILIPS ELECTRONICS (THAILAND) Ltd.,
209/2 Sanpavuth-Bangna Road Prakanong, BANGKOK 10260,
Tel. +66 2 745 4090, Fax. +66 2 398 0793

Turkey: Talatpasa Cad. No. 5, 80640 GÜLTEPE/ISTANBUL,
Tel. +90 212 279 2770, Fax. +90 212 282 6707

Ukraine: PHILIPS UKRAINE, 4 Patrice Lumumba str., Building B, Floor 7,
252042 KIEV, Tel. +380 44 264 2776, Fax. +380 44 268 0461

United Kingdom: Philips Semiconductors Ltd., 276 Bath Road, Hayes,
MIDDLESEX UB3 5BX, Tel. +44 181 730 5000, Fax. +44 181 754 8421

United States: 811 East Arques Avenue, SUNNYVALE, CA 94088-3409,
Tel. +1 800 234 7381

Uruguay: see South America

Vietnam: see Singapore

Yugoslavia: PHILIPS, Trg N. Pasica 5/v, 11000 BEOGRAD,
Tel. +381 11 625 344, Fax. +381 11 635 777

For all other countries apply to: Philips Semiconductors, Marketing & Sales Communications,
Building BE-p, P.O. Box 218, 5600 MD EINDHOVEN, The Netherlands, Fax. +31 40 27 24825

Internet: <http://www.semiconductors.philips.com>

© Philips Electronics N.V. 1996

SCA52

All rights are reserved. Reproduction in whole or in part is prohibited without the prior written consent of the copyright owner.

The information presented in this document does not form part of any quotation or contract, is believed to be accurate and reliable and may be changed without notice. No liability will be accepted by the publisher for any consequence of its use. Publication thereof does not convey nor imply any license under patent- or other industrial or intellectual property rights.

Printed in The Netherlands

537021/1200/02/pp20

Date of release: 1996 Nov 7

Document order number: 9397 750 01469

Let's make things better.

Philips



PHILIPS