

9097247 TOSHIBA. ELECTRONIC

02E 16897 D

T-74-05-D1

# TA7140P

## VOLTAGE AMPLIFIER

### LOW OUTPUT POWER AMPLIFIER

- Especially Suitable for Line Output Amplifier Recording Head Driver and Headphone Driver of Tape Recorder Deck.
- Low Noise :  $V_{NI}=1\mu V_{rms}$
- Wide Operating Supply Voltage Range  
:  $V_{CC}=3.5\sim 25V$
- 150mW Audio Output Power at  $V_{CC}=20V, R_L=150\Omega$

Unit in mm

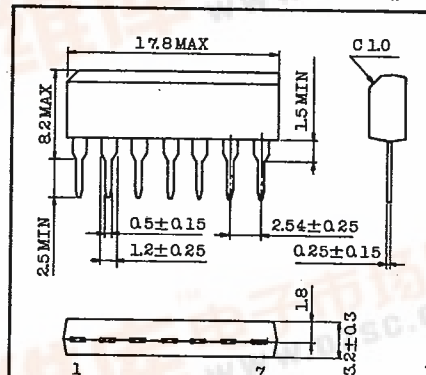

Lead pitch is 2.54 and tolerance is  $\pm 0.25$  against theoretical center of each lead that is obtained on the basis of No.1 lead.

JEDEC -  
TOSHIBA S7A-P

### MAXIMUM RATINGS ( $T_a=25^\circ C$ )

CHARACTERISTIC	SYMBOL	RATING	UNIT
Supply Voltage	$V_{CC}$	25	V
Power Dissipation (Note)	$P_D$	400	mW
Operating Temperature	$T_{opr}$	$-25\sim 75$	$^\circ C$
Storage Temperature	$T_{stg}$	$-55\sim 125$	$^\circ C$

Note: Derated above  $T_a=25^\circ C$  in the proportion of  $4mW/^\circ C$ .

### ELECTRICAL CHARACTERISTICS (Unless otherwise specified)

$V_{CC}=20V, T_a=25^\circ C, R_L=150\Omega, R_f=100\Omega, R_g=600\Omega, f=1kHz$

CHARACTERISTIC	SYMBOL	TEST CIR-CUIT	TEST CONDITION	MIN.	TYP.	MAX.	UNIT
Operating Supply Voltage Range	$V_{CCopr}$	-	-	3.5	20	25	V
Supply Current	$I_{CC}$	-	$f=1kHz, V_{OUT}=0$	-	4.0	6.0	mA
			$V_{OUT}=4.5V_{rms}$	-	16.5	-	
Voltage Gain (Open Loop)	$G_{VO}$	-	$R_f=0\Omega$	-	63	-	dB
Voltage Gain (Closed Loop) (Note)	$G_V$	-	-	36.5	40	43.5	dB
Total Harmonic Distortion	THD	-	$V_{OUT}=4.5V_{rms}$	-	0.5	1	%
			$V_{CC}=6.5V, V_{OUT}=1.0V_{rms}$	-	1	-	
Maximum Output Voltage	$V_{OM}$	-	THD=10%	-	6	-	$V_{rms}$
Input Resistance	$R_{IN}$	-	-	-	30	-	$k\Omega$
Output Noise Voltage	$V_{NO}$	-	$BW=20Hz\sim 20kHz, R_g=1k\Omega$	-	100	200	$\mu V_{rms}$

Note: In regard to the value of voltage gain (closed loop), it is possible to be classified.

**TOSHIBA**

# TA7140P

T-74-05-01

## EQUIVALENT CIRCUIT

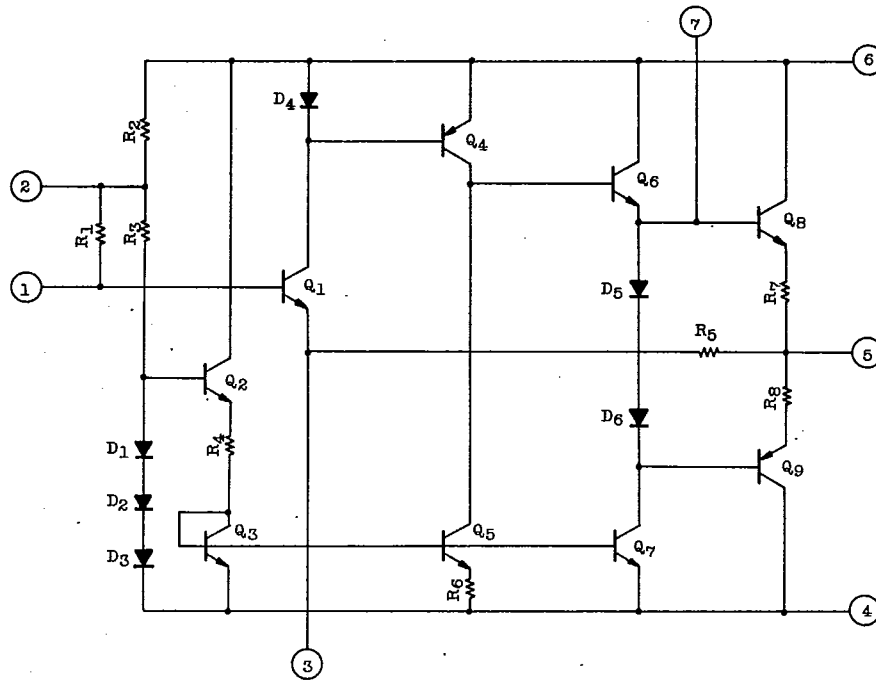

## TEST CIRCUIT

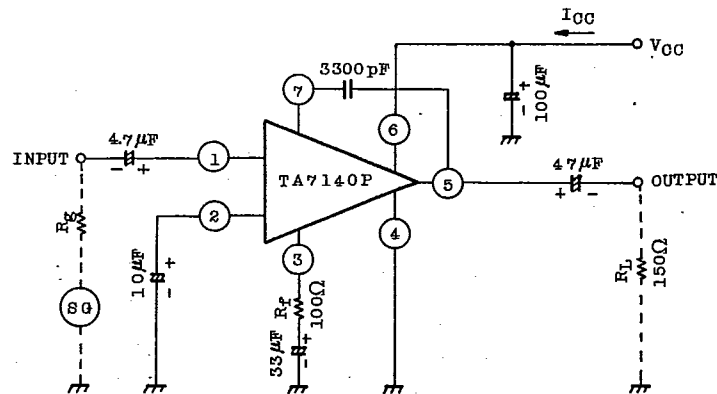

AUDIO LINEAR IC

**TA7140P**

T-74-05-01

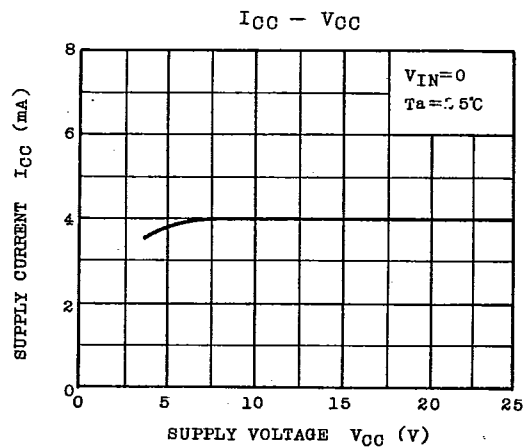
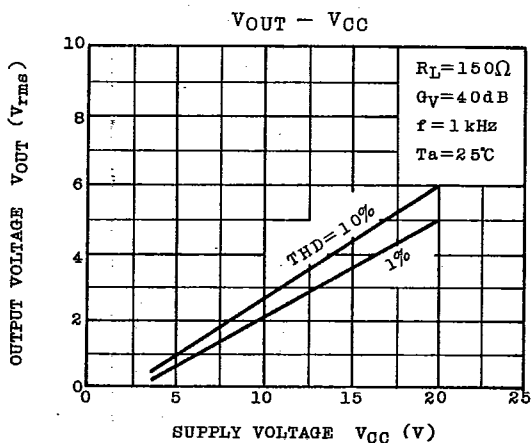
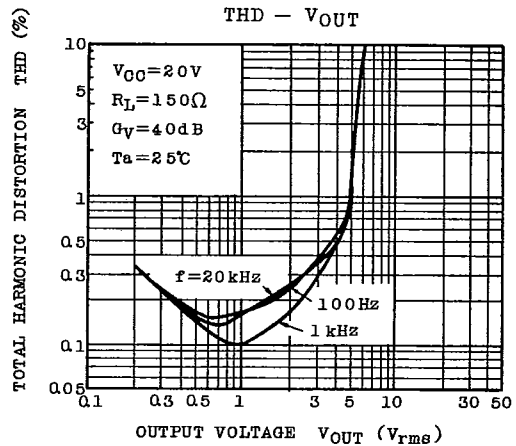
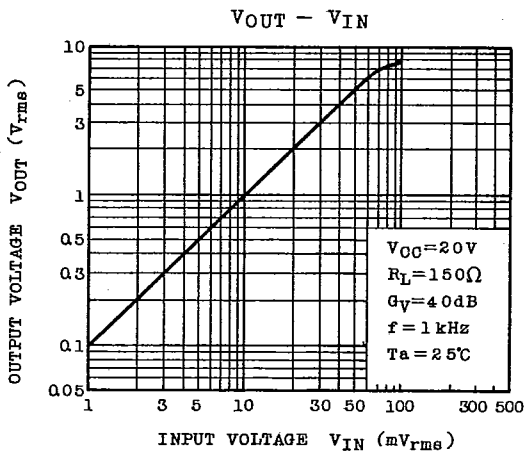
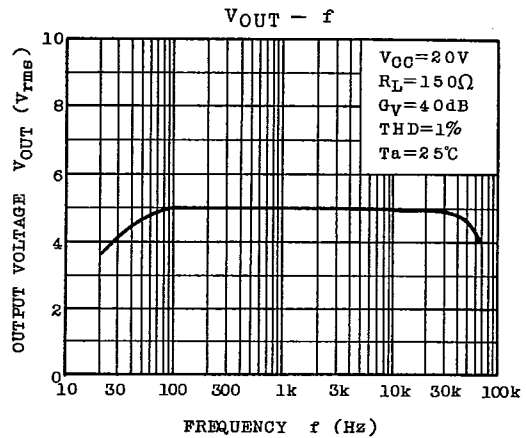
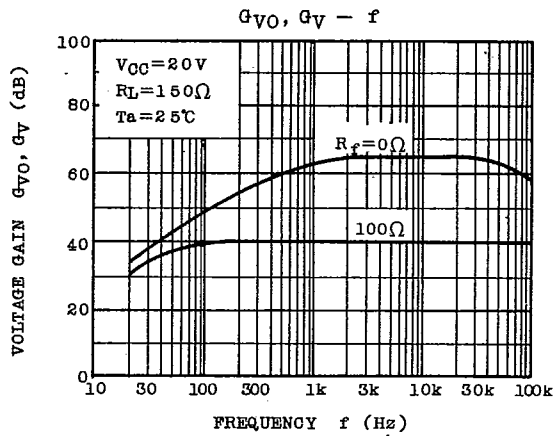

# TA7140P

T-74-05-01

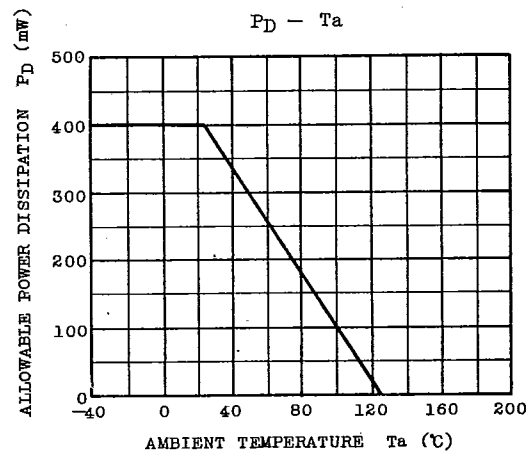
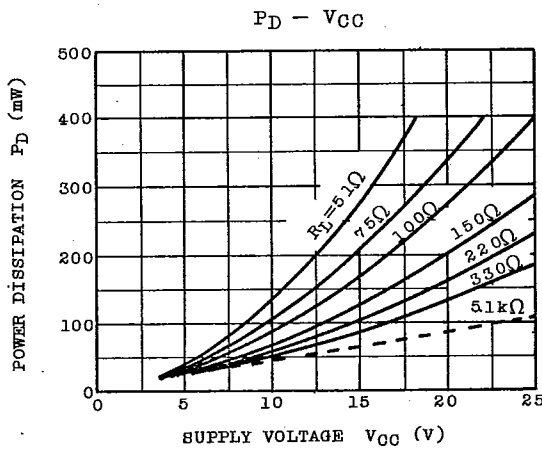
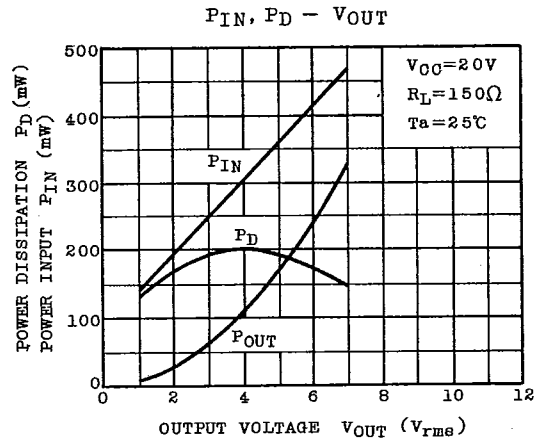
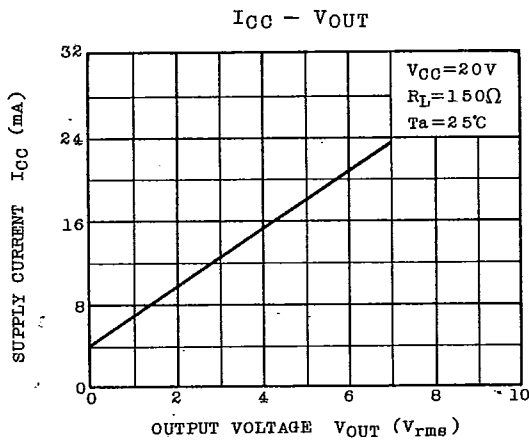
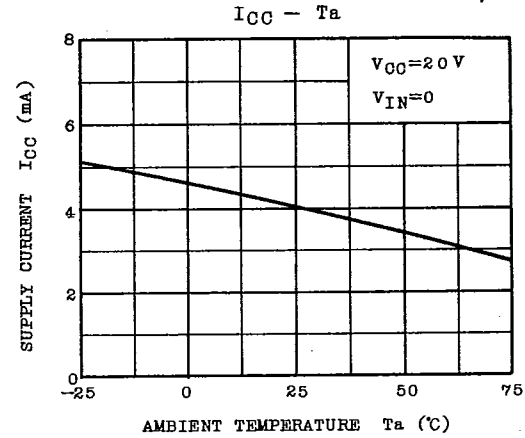
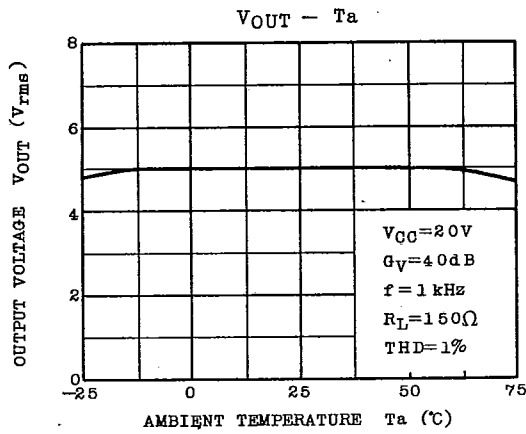

AUDIO LINEAR IC

# TA7140P

T-74-05-01

## APPLICATION CIRCUIT

### 1. HEADPHONE AMPLIFIER

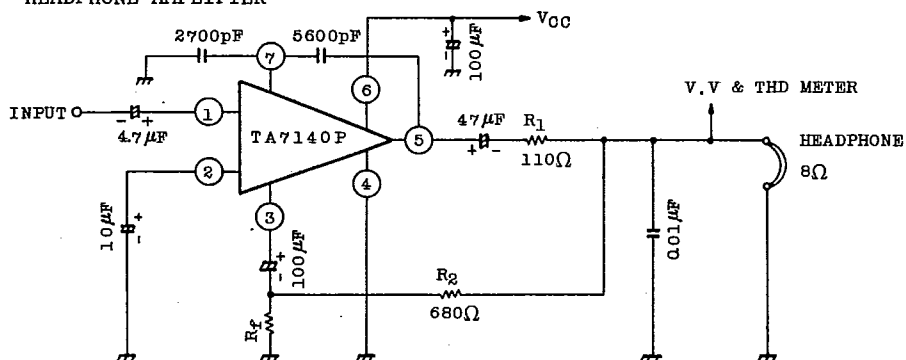

### 2. BUFFER AMPLIFIER ( $G_V=9\text{dB}$ )

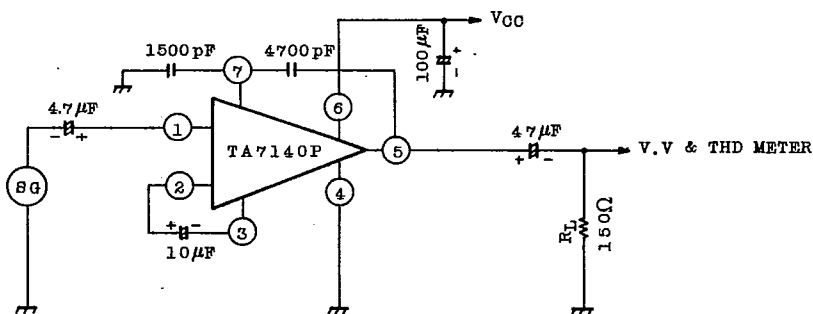

### 3. FLAT AMPLIFIER

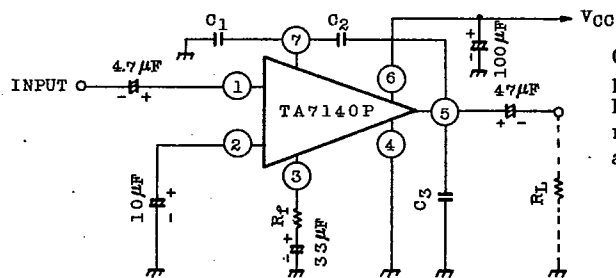

C1, C2 and C3 are for preventing parasitic oscillation. For various closed loop gain, recommended compensation values are shown in the following table.

VOLTAGE GAIN

$G_V$	40dB	30dB	20dB	10dB	0dB
$R_f$ [ $\Omega$ ]	100	330	1.1k	4.7k	$\infty$ (open)
$C_1$ [pF]	0	1500	1500	1500	1500
$C_2$ [pF]	3300	4700	4700	4700	4700
$C_3$ [pF]	0	0	0	0	2200

# TA7140P

T-74-05-01

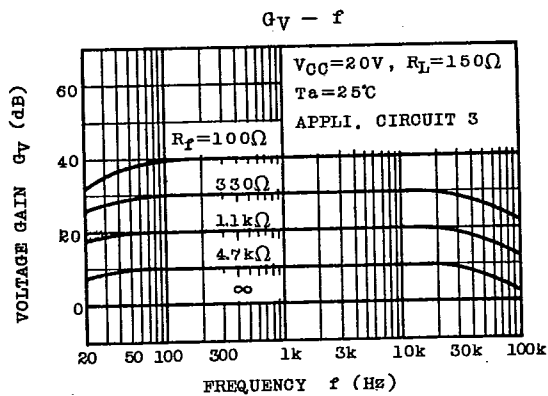
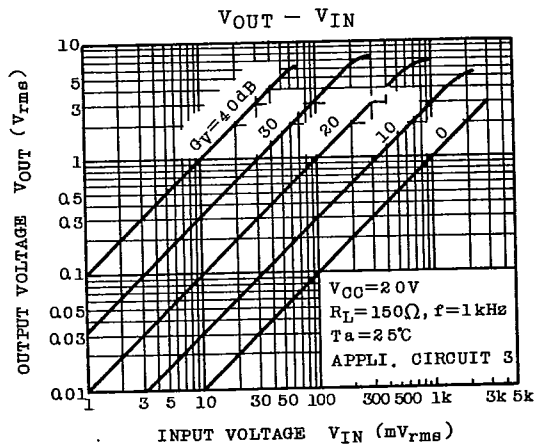
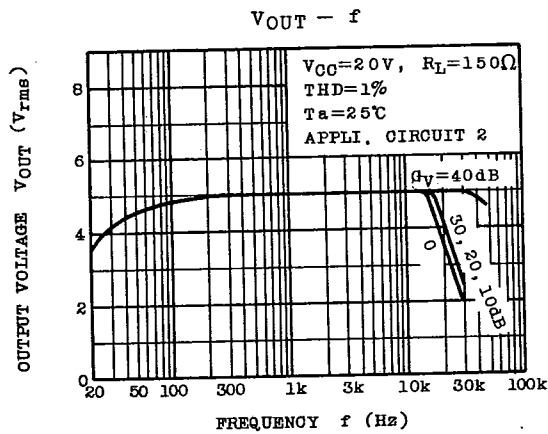
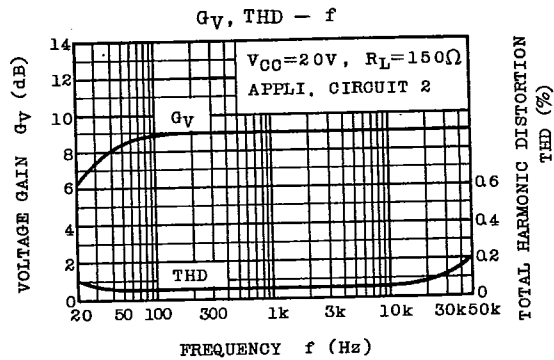
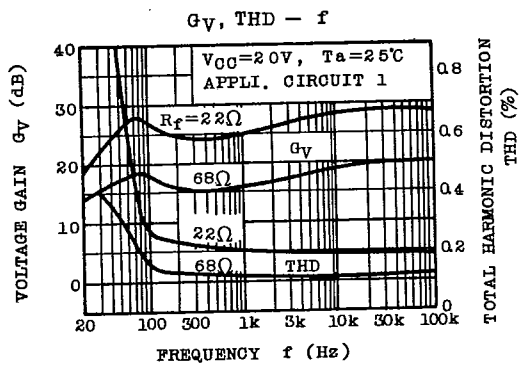

AUDIO LINEAR IC