

A8430

White LED Driver Constant Current Step-up Converter

A8430 MLPD

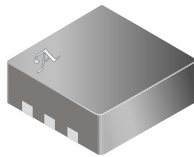

Approximate actual size

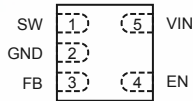

Same pad footprint as SOT-23-5
R_{0JA} = 50 °C/W, see note 1, page 2

ABSOLUTE MAXIMUM RATINGS

SW Pin	-0.3 V to 36 V
Remaining Pins	-0.3 V to 10 V
Ambient Operating Temperature, T _A	-40°C to 85°C
Junction Temperature, T _{J(max)}	150°C
Storage Temperature, T _S	-55°C to 150°C

The A8430 is a noninverting boost converter that steps-up the input voltage, to provide a programmable constant current output at up to 36 V for driving white LEDs in series. Driving LEDs in series ensures identical currents and uniform brightness. Up to four white LEDs can be driven at 20 mA from a single cell Li-ion or a multicell NiMH power source. Up to seven white LEDs can be driven by increasing the supply voltage up to 10 V.

The A8430 incorporates a power switch and feedback sense amplifier to provide a solution with minimum external components. The output current can be set by adjusting a single external sense resistor and can be varied with a voltage or filtered PWM signal when dimming control is required. The high switching frequency of 1.2 MHz allows the use of small inductor and capacitor values.

The A8430 is provided in a 5-pin 3 mm x 3 mm MLP package (part number suffix *EK*), that has a nominal height of only 0.75 mm. The lead-free version (part number suffix *EK-T*) has 100% lead-free matte tin leadframe plating.

FEATURES

- Output voltage up to 36 V
- 2.5 V to 10 V input
- Drives up to 4 LEDs at 20 mA from a 2.5 V supply
- Drives up to 5 LEDs at 20 mA from a 3 V supply
- 1.2 MHz switching frequency
- 300 mA switch current limit
- 1 µA shutdown current

APPLICATIONS

- LED backlights
- Portable battery-powered equipment
- Cellular phones
- PDAs (Personal Digital Assistant)
- Camcorders, personal stereos, MP3 players, cameras
- Mobile GPS systems

Use the following complete part number when ordering:

Part Number	Package	Description
A8430EEK	5-pin, MLPD	Surface Mount
A8430EEK-T	5-pin, MLPD	Lead-Free, Surface Mount



A8430

White LED Driver Constant Current Step-up Converter

Functional Block Diagram

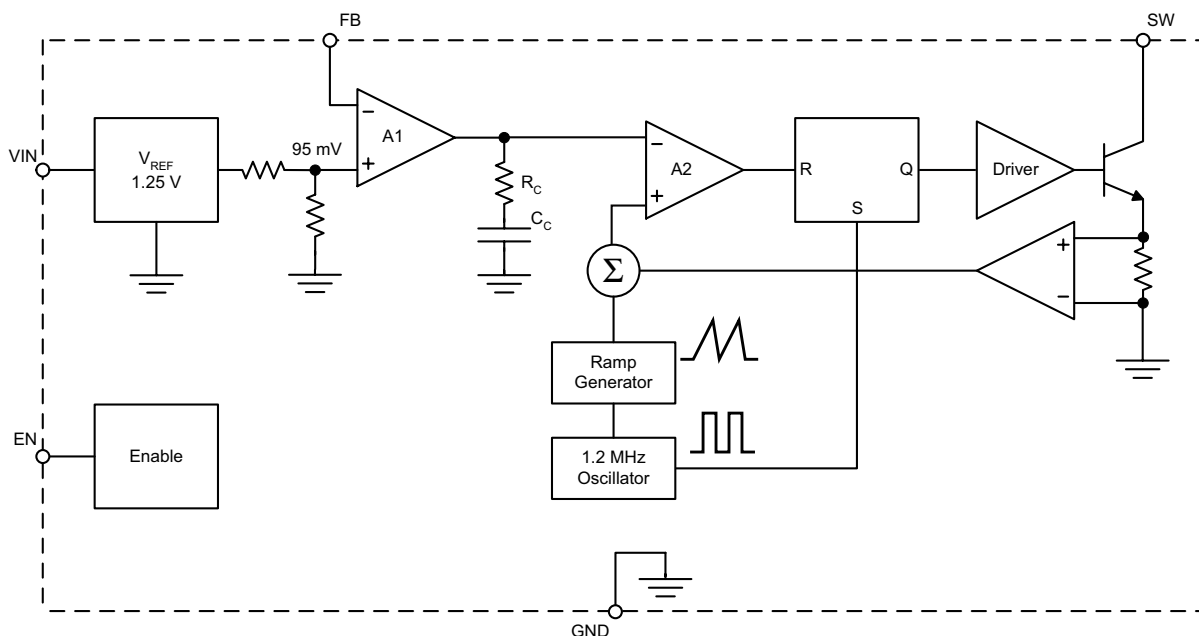

ELECTRICAL CHARACTERISTICS at $T_A = 25^\circ\text{C}$, $V_{IN} = 3\text{V}$ (unless otherwise noted)

Characteristics	Symbol	Test Conditions	Min.	Typ.	Max.	Units
Input Voltage Range	V_{IN}	–	2.5	–	10	V
Supply Current	I_{SUP}	Active: $I_{LOAD} = 15\text{mA}$, $V_{LOAD} = 12\text{V}$	–	2.5	3.5	mA
		Shutdown (EN=0V)	–	0.1	1	μA
Feedback Reference Voltage	V_{REF}	–	86	95	104	mV
Feedback Input Current	I_{FB}	–	–	20	75	nA
Switch Current Limit	I_{SWLIM}	–	–	300	–	mA
Switch Frequency	F_{SW}	–	0.8	1.2	1.6	MHz
Switch Maximum Duty Cycle	D	–	85	90	–	%
Switch Saturation voltage	$V_{CE(SAT)}$	–	–	350	–	mV
Switch Leakage Current	I_{SL}	–	–	–	5	μA
Enable Input						
Input Threshold Low	V_{IL}	–	–	–	0.4	V
Input Threshold High	V_{IH}	–	1.5	–	–	V
Input Leakage	Leakage	I_{IL}	–	–	1	μA

Note 1. Measured with 4-layer PCB. Please refer to application note “Package Thermal Characteristics,” for thermal performance measurement for 3 mm x 3 mm MLP package for additional information.

A8430

White LED Driver Constant Current Step-up Converter

Operating Characteristics

Using Typical Application Circuit (Schematic 1)

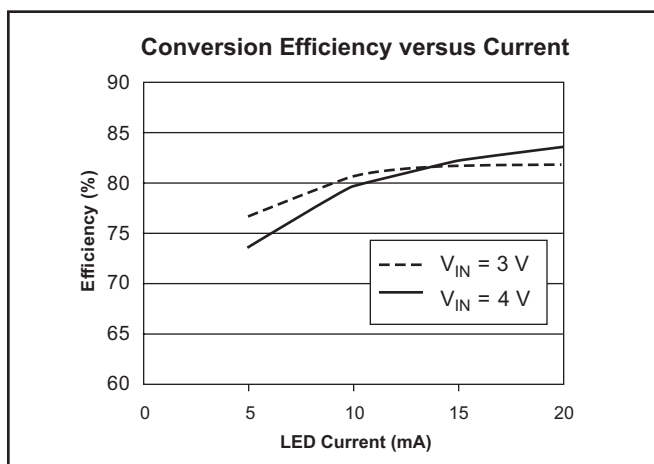
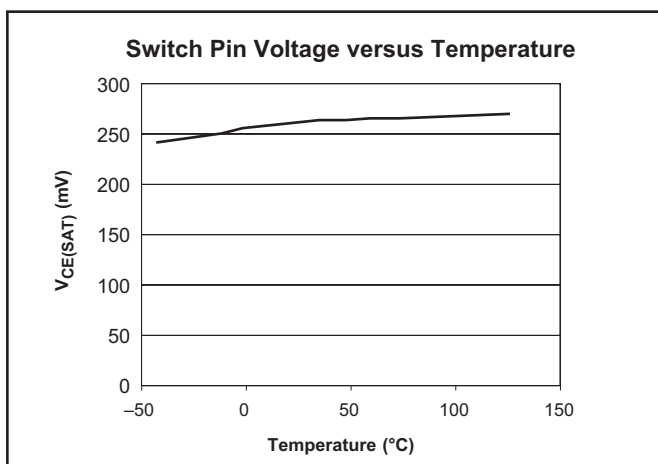
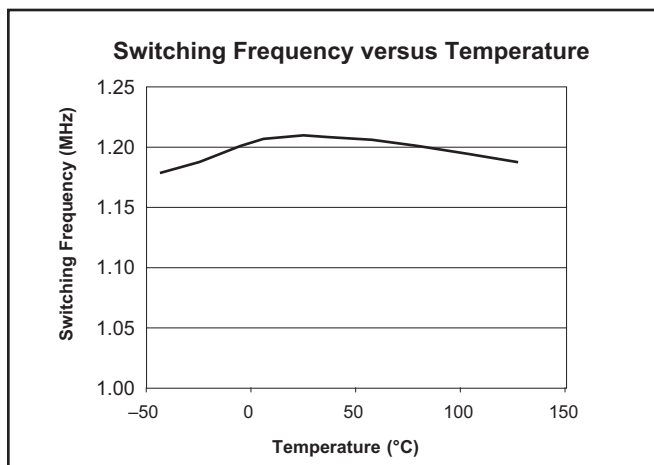
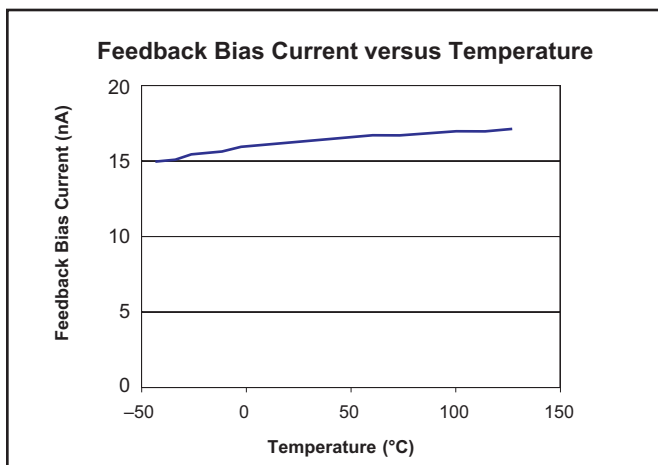
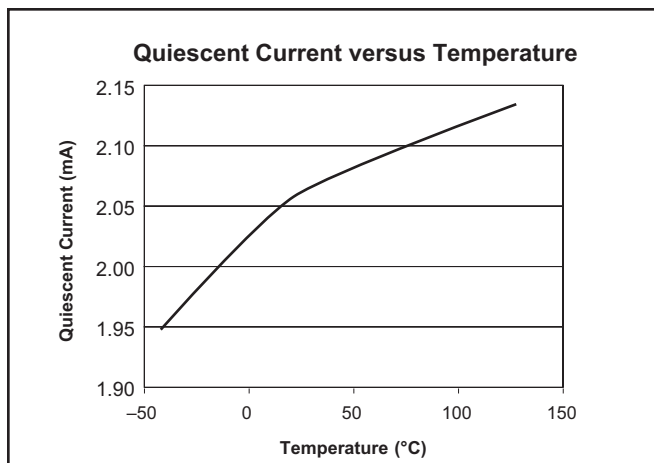
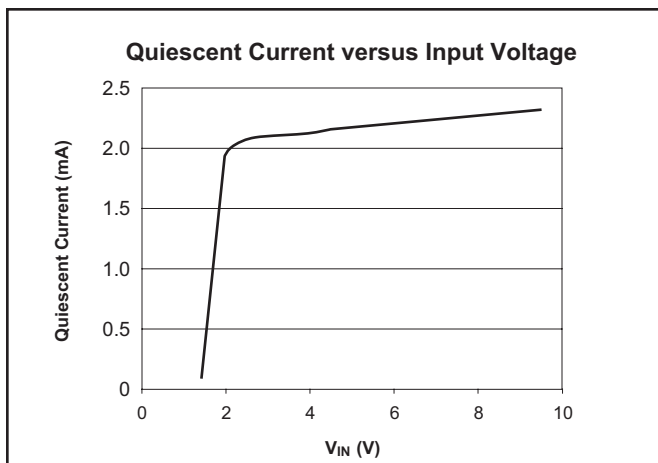

A8430

White LED Driver Constant Current Step-up Converter

Functional Description

Typical Application

A typical application circuit for the A8430 is provided in schematic diagram 1. This illustrates a method of driving three white LEDs in series. The conversion efficiency of this configuration is shown in chart 1.

Pin Functions

The diagram also shows a method of connecting the individual pins, whose functions are described as follows:

VIN. Supply to the control circuit. A bypass capacitor must be connected from close to this pin to GND.

SW. Low-side switch connection between the inductor (L1) and ground. Because rapid changes of current occur at this pin,

the traces on the PCB that are connected to this pin should be minimized. In addition, the inductor (L1) and diode (D1) should be connected as close to this pin as possible.

EN. Setting lower than 0.4 V disables the A8430 and puts the control circuit into the low-power Sleep mode. Greater than 1.5 V fully enables the A8430.

GND. Ground reference connected directly to the ground plane. The sense resistor (R1) should have a separate connection directly to this point.

FB. Feedback pin for LED current control. The reference voltage is 95 mV. The top of the sense resistor (R1) is typically connected to this pin.

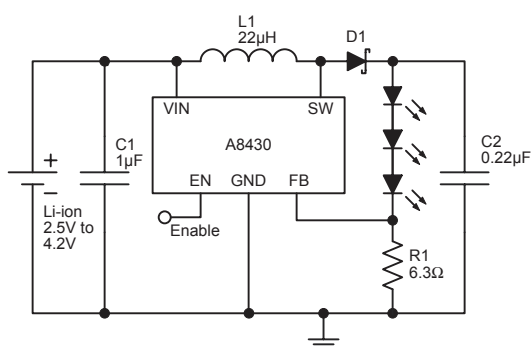

Schematic 1. Typical application

Conversion Efficiency versus Input Voltage

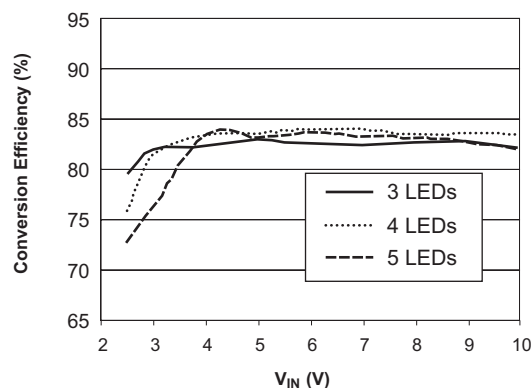

Chart 1. Conversion efficiency when driving various quantities of LEDs in the typical application circuit

A8430

White LED Driver Constant Current Step-up Converter

Device Operation

The A8430 uses a constant-frequency, current-mode control scheme to regulate the current through the load. The load current produces a voltage across the external sense resistor (R1) and the input at the FB pin. This voltage is then compared to the internal 95 mV reference to produce an error signal. The switch current is sensed by the internal sense resistor and compared to the load current error signal. As the load current increases, the error signal diminishes, reducing the maximum switch current and thus the current delivered to the load. As the load current decreases, the error signal rises, increasing the maximum switch current and thus increasing the current delivered to the load.

To set the load current, ensure that the required internal reference value of 95 mV is produced at the desired load. To do so, select a resistance value for the sense resistor, R1 (Ω), such that:

$$R1 = 95 \text{ mV} / I_{\text{LOAD}}$$

where I_{LOAD} is the target load current (mA).

The table below shows typical values for R1. Note that the resistance value is from the standard E96 series.

As load current is reduced, the energy required in the inductor diminishes, resulting in the inductor current dropping to zero for low load current levels. This is known as Discontinuous mode operation, and results in some low-frequency ripple. The average load current, however, remains regulated down to zero.

In Discontinuous mode, when the inductor current drops to zero, the voltage at the SW pin rings, due to the capacitance in the resonant LC circuit formed by the inductor and the capacitance of the switch and the diode. This ringing is low-frequency and is not harmful. It can be damped with a resistor across the inductor, but this reduces efficiency and is not recommended.

Power Dissipation versus I_{OUT}

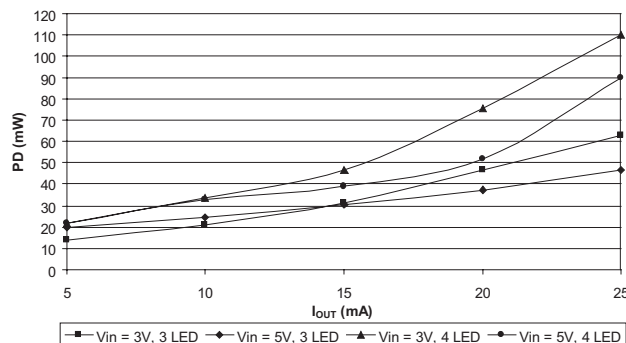

Target Load Current (I_{LOAD}) (mA)	Sense Resistor (R1) (Ω)
5	19.1
10	9.53
12	7.87
15	6.34
20	4.75

A8430

White LED Driver Constant Current Step-up Converter

Application Information

Component Selection

The component values shown in schematic 1 are sufficient for most applications. To reduce the output ripple the inductor may be increased, but in most cases this results in excessive board area and cost.

Inductor Selection. With an internal PWM frequency of 1.2 MHz, the optimal inductor value for most cases is 22 μ H. The inductor should have low winding resistance, typically $< 1 \Omega$, and the core should have low losses when operating at 1.2 MHz. For worst case conditions, high output voltage and current and low input voltage, the inductor should be rated at the switch current limit, I_{SWLIM} . If high temperature operation is required a derating factor will have to be considered. In some cases, where lower inductor currents are expected, the current rating can be decreased. Several inductor manufacturers have and are developing suitable small-size inductors, including: Murata, Panasonic, Sumida, Taiyo Yuden, and TDK.

Diode Selection. The diode should have a low forward voltage to reduce conduction losses. In addition, it should have a low capacitance to reduce switching losses. Schottky diodes can provide both these features, if carefully selected. The forward voltage drop is a natural advantage for Schottky diodes, and it reduces as the current rating increases. However, as the current rating increases, the diode capacitance also increases. As a result, the optimal selection is usually the lowest current rating above the circuit maximum. With the A8430, a current rating in the range from 100 mA to 200 mA is usually sufficient.

Capacitor Selection. Because the capacitor values are low, ceramic capacitors are the best choice for use with the A8430. To reduce performance variation as temperature changes, low drift capacitor types, such as X7R and X5R, should be used. Suitable capacitors are available from: Taiyo Yuden, Murata, Kemet, and AVX.

Dimming Control

LED brightness can be controlled either by modifying the voltage at the top of the sense resistor (R1) to control the LED current, I_{LOAD} , directly, or by using a PWM signal on the EN pin to chop the output.

Feedback modulation. By adding a voltage drop between the FB pin and R1 (the sense resistor), as shown in schematic 2, the LED current, I_{LOAD} , can be made to decrease. As V_C (control voltage) increases, the voltage drop across R2 also increases. This causes the voltage at FB to increase, and the A8430 reduces I_{LOAD} to compensate. As V_C increases further, the current drops to zero, and R2 maintains the full 95 mV on FB. Reducing V_C diminishes the voltage across R2 until, at 95 mV on V_C , there is no drop across R2 and the current level is defined by R1. Reducing V_C below 95 mV causes I_{LOAD} to increase further, due to the voltage drop across R2 in the reverse direction. This continues until, at zero volts on V_C , there is approximately 5 mV across R2. At that point, I_{LOAD} (mA), is defined as:

$$I_{LOAD} = 100 \text{ mV} / R1$$

where R1 is the resistance of the sense resistor (Ω).

PWM Control. LED dimming control can also be generated by a filtered PWM signal as shown in schematic 3. In this case, a 0% duty cycle (PWM=0 V) corresponds to full brightness and a 100% duty cycle causes the LED current, I_{LOAD} , to go to zero.

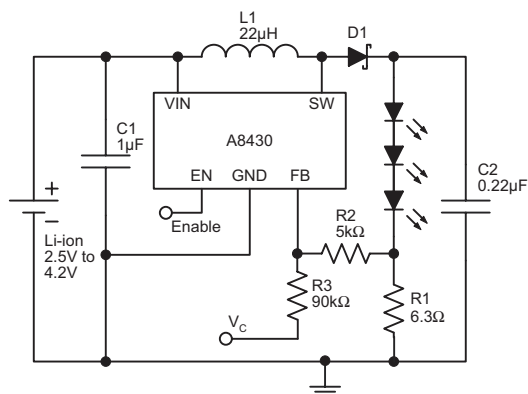

Schematic 2. Dimming control with dc voltage feedback modulation

A8430

White LED Driver Constant Current Step-up Converter

By applying a PWM signal directly to the EN pin, the A8430 is turned on or off, and I_{LOAD} is either full (as defined by R1) or zero. By varying the duty cycle of the PWM signal, the LED brightness can be controlled from off (0% duty cycle) to full (100% duty cycle). The PWM frequency should be in the range from 1 kHz to 10 kHz.

Several other schemes are possible, for example, digitally switching additional resistors across R1 to increase I_{LOAD} . In this case, R1 would be selected for the minimum desired brightness.

Soft Start-Up

To provide fast start-up operation, no soft start is implemented in the control circuit. At power-on, the bypass capacitor (C1) is discharged, which means that the supply must provide the in-rush current through the inductor.

This can be reduced by modulating the feedback with a soft-start circuit as shown in schematic 4. When power is first applied, the capacitor C3 is discharged and pulls the FB pin high, reducing the output drive to minimum. As C3 charges, when the bottom drops below about 0.8 V, the feedback from the sense resistor (R1) takes over full control of the output current.

Overvoltage Protection

An overvoltage event can occur when the LEDs become disconnected or fail in an open state. In these cases, the current flow through the sense resistor becomes zero, thus the feedback voltage becomes zero. The A8430 compensates by increasing the on time of the switch, which increases the output voltage.

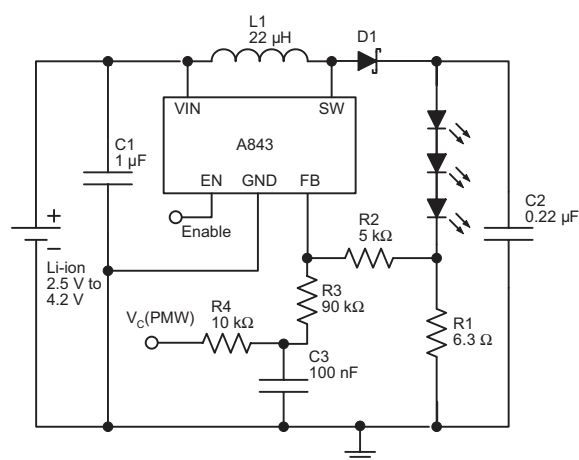

Schematic 3. Dimming control with filtered PWM

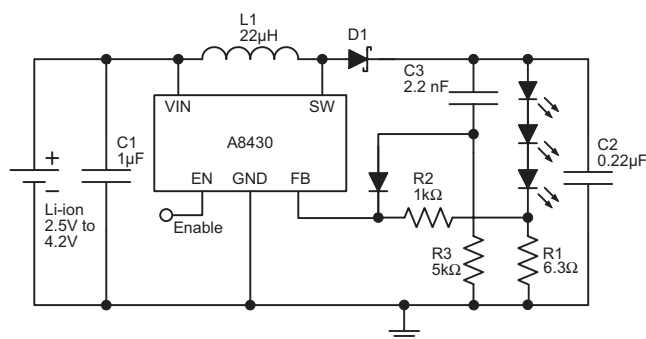

Schematic 4. Soft start operation

A8430

White LED Driver Constant Current Step-up Converter

Overvoltage protection for the A8430 requires a Zener diode to clamp the output voltage, as shown in schematic 5. The Zener voltage should be greater than the maximum output voltage of the LED string. The Zener diode also should be able to sink more than 0.1 mA of current.

Parallel LED Strings

The A8430 can be used to power parallel strings of LEDs, which have the same number of LEDs on each string. It is important that the voltage drop is the same across all of the parallel strings, to ensure that all of the LEDs are illuminated and that the current through each string is equal.

A typical circuit with two parallel strings is shown in schematic 6. The conversion efficiency of this configuration is shown in chart 2.

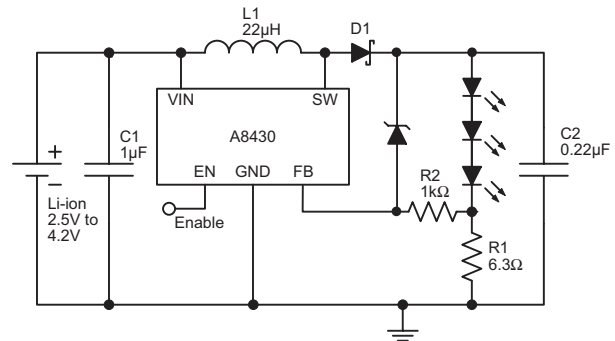

Schematic 5. Overvoltage protection with Zener clamp

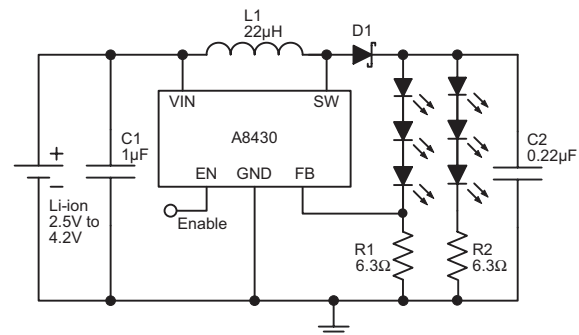

Schematic 6. Parallel strings of LEDs

Conversion Efficiency for Two Parallel Strings

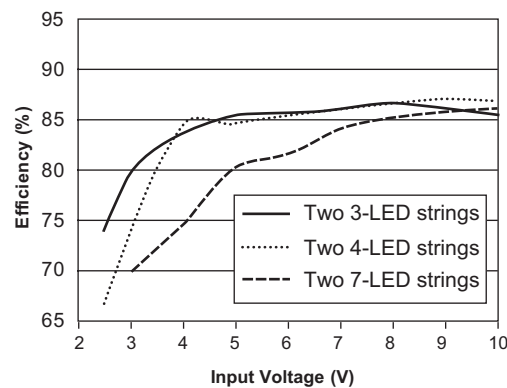

Chart 2. Conversion efficiency when driving two parallel strings of varying lengths

A8430

White LED Driver Constant Current Step-up Converter

Terminal List Table

Pin	Name	Function
1	SW	Internal power FET
2	GND	Ground
3	FB	Feedback input
4	EN	Enable input
5	VIN	Input supply

Package EK

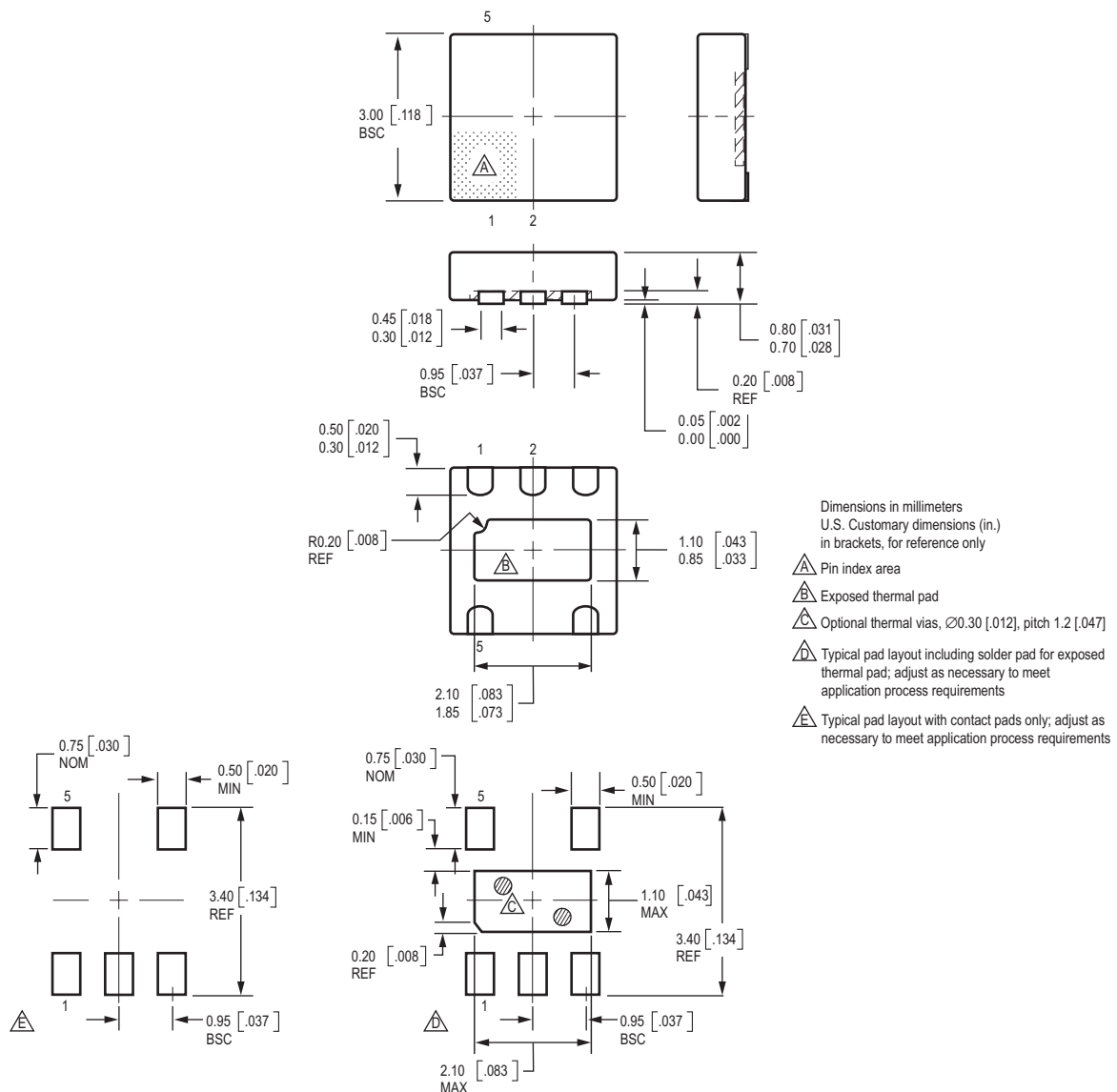

A8430
White LED Driver Constant Current Step-up Converter

The products described here are manufactured under one or more U.S. patents or U.S. patents pending.

Allegro MicroSystems, Inc. reserves the right to make, from time to time, such departures from the detail specifications as may be required to permit improvements in the performance, reliability, or manufacturability of its products. Before placing an order, the user is cautioned to verify that the information being relied upon is current.

Allegro products are not authorized for use as critical components in life-support devices or systems without express written approval.

The information included herein is believed to be accurate and reliable. However, Allegro MicroSystems, Inc. assumes no responsibility for its use; nor for any infringement of patents or other rights of third parties which may result from its use.

Copyright©2003, 2004, 2005 AllegroMicrosystems, Inc.