



Not Intended For New Designs

Comlinear CLC231  
Fast Settling, Wideband Buff-Amp™ (A<sub>v</sub> = ±1 to ±5)

# Comlinear CLC231 Fast Settling, Wideband Buff-Amp™ (A<sub>v</sub> = ±1 to ±5)

## General Description

The CLC231 Buff-Amp™ is a wideband operational amplifier **designed specifically for high-speed, low-gain applications**. The CLC231 is based on Comlinear's proprietary op amp topology—a unique design that both eliminates the gain-bandwidth tradeoff and permits unprecedented high-speed performance. (See table below.)

The CLC231 Buff-Amp™ is the **ideal design alternative to low-precision open-loop buffers and oscillation-prone conventional op amps**. The CLC231 offers precise gains from ±1.000 to ±5.000 and linearity that is a true .1%—even for demanding 50 ohm loads. Open-loop buffers, on the other hand, offer a nominal gain of .95 ± .03 and a linearity of only 3% for typical loads. A buffer's settling time may look impressive but it is usually specified at unrealistically large load resistances or when the effects of thermal tail are not included; the CLC231 Buff-Amp™ settles to .05% in 15ns—while driving a 100 ohm load.

Offsets and drifts, usually a low priority in conventional high-speed op amp designs, were not ignored in the CLC231; the input offset voltage is typically 1mV and **input offset voltage drift is only 10μV/°C**. The CLC231 is stable and oscillation-free across the entire gain range and since it's **internally compensated**, the user is saved the trouble of designing external compensation networks and having to "tweak" them in production. The absence of a gain-bandwidth tradeoff in the CLC231 allows performance to be predicted easily; the table below shows how the bandwidth is affected very little by changing the gain setting.

The CLC231 is constructed using thin film resistor/bipolar transistor technology, and is available in the following versions:

- CLC231AI -25°C to +85°C 12-pin TO-8 can
- CLC231A8C -55°C to +125°C 12-pin TO-8 can, MIL-STD-883, Level B
- CLC231AK -55°C to +125°C 12-pin TO-8 can, features burn-in and hermetic testing
- CLC231AM -55°C to +125°C 12-pin TO-8 can, screened to Comlinear's M standard for high reliability

DESC SMD number: 5962-89594

## Typical Performance

parameter	gain setting						units
	1	2	5	-1	-2	-5	
-3dB bandwidth	180	165	130	165	150	115	MHz
rise time (2V)	1.8	2.0	2.5	2.0	2.2	2.9	ns
slew rate	2.5	3	3	3	3	3	V/ns
settling time (to .1%)	12	12	12	12	12	15	ns

## Features

- 165MHz closed-loop -3dB bandwidth
- 15ns settling to 0.05%
- 1mV input offset voltage, 10μV/°C drift
- 100mA output current
- Excellent AC and DC linearity

## Applications

- Driving flash A/D converters
- Precision line driving (a gain of 2 cancels matched-line losses)
- DAC current-to-voltage conversion
- Low-power, high-speed applications (50mW @ ±5V)

Small Signal Pulse Response

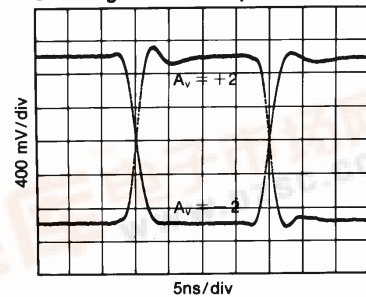

Bottom View

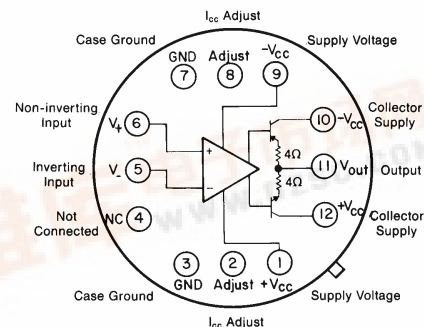

Pins 2 and 8 are used to adjust the supply current or to adjust the offset voltage (see text). These pins are normally left unconnected.

## Package Dimensions

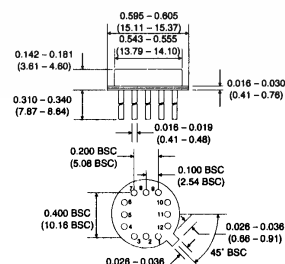

# CLC231 Electrical Characteristics ( $A_v = +2$ , $V_{cc} = \pm 15V$ , $R_L = 100\Omega$ , $R_f = 250\Omega$ ; unless specified)

PARAMETERS	CONDITIONS	TYP	MAX & MIN RATINGS			UNITS	SYMBOL
Ambient Temperature	CLC231A8/AK	+25°C	-55°C	+25°C	+125°C		
Ambient Temperature	CLC231AI	+25°C	-25°C	+25°C	+85°C		
<b>FREQUENCY DOMAIN PERFORMANCE</b>							
* -3dB bandwidth note 2	$V_{out} \leq 2V_{pp}$	165	>145	>145	>120	MHz	SSBW
gain flatness note 2	$V_{out} \leq 10V_{pp}$	95	>80	>80	>60	MHz	FPBW
* peaking	$V_{out} \leq 2V_{pp}$	0.1	<0.6	<0.3	<0.6	dB	GFPL
* peaking	0.1 to 50MHz	0.1	<1.5	<0.3	<0.8	dB	GFPH
* rolloff	>50MHz	0.4	<0.6	<0.6	<1.0	dB	GFR
group delay	at 100MHz	3.5±0.5	—	—	—	ns	GD
linear phase deviation	to 100MHz	0.5	<2	<2	<2	°	LPD
reverse isolation	to 100MHz						
non-inverting		53	>43	>43	>43	dB	RINI
inverting		36	>26	>26	>26	dB	RIIN
<b>TIME DOMAIN PERFORMANCE</b>							
rise and fall time	2V step	2	<2.4	<2.3	<2.7	ns	TRS
	10V step	5.0	<7.0	<6.5	<6.5	ns	TRL
settling time to .05%	5V step	15	—	—	—	ns	TS
to .1%	2.5V step	12	<22	<17	<22	ns	TSP
overshoot	5V step	5	<15	<10	<15	%	OS
slew rate (overdriven input)		3	>2.5	>2.5	>1.8	V/ns	SR
overload recovery	<1% error						
<50ns pulse, 200% overdrive		120	—	—	—	ns	OR
<b>DISTORTION AND NOISE PERFORMANCE</b>							
* 2nd harmonic distortion	0dBm, 20MHz	-55	<-47	<-47	<-47	dBc	HD2
* 3rd harmonic distortion	0dBm, 20MHz	-59	<-47	<-47	<-47	dBc	HD3
equivalent input noise							
noise floor	>5MHz	-153	<-150	<-150	<-150	dBm(1Hz)	SNF
integrated noise	5MHz to 200MHz	70	<100	<100	<100	$\mu V_{rms}$	INV
<b>STATIC, DC PERFORMANCE</b>							
* input offset voltage		1	<4.0	<2.0	<4.5	mV	VIO
temperature coefficient		10	<25	<25	<25	$\mu V/^\circ C$	DVIO
* input bias current	non-inverting	5	<29	<21	<31	$\mu A$	IBN
temperature coefficient		50	<125	<125	<125	$nA/^\circ C$	DIBN
* input bias current	inverting	10	<31	<15	<35	$\mu A$	IBI
temperature coefficient		125	<200	<200	<200	$nA/^\circ C$	DIBI
* power supply rejection ratio		50	>45	>45	>45	dB	PSRR
common mode rejection ratio		46	>40	>40	>40	dB	CMRR
* supply current	no load	18	<22	<22	<22	mA	ICC
<b>MISCELLANEOUS PERFORMANCE</b>							
non-inverting input resistance		400	>100	>200	>400	$k\Omega$	RIN
capacitance		1.3	<2.5	<2.5	<2.5	pF	CIN
output impedance	at 100MHz	5.37	—	—	—	$\Omega, nH$	ZO
output voltage range	no load	±12	>±11	>±11	>±11	V	VO

Min/max ratings are based on product characterization and simulation. Individual parameters are tested as noted. Outgoing quality levels are determined from tested parameters.

## Absolute Maximum Ratings

Input and Common Mode Voltage Limits

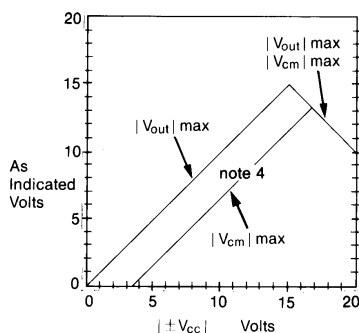

supply voltage $V_{cc}$	±20V
output current	±100mA
thermal resistance ( $\theta_{ca}$ )	see thermal model
junction temperature	+175°C
operating temperature	AI: -25°C to +85°C
	A8/AK: -55°C to +125°C
storage temperature	-65°C to +150°C
lead temperature (soldering 10s)	+300°C

**\*note 1:** Parameters preceded by an \* are the final electrical test parameters and are 100% tested. A8 and AK units are tested at -55°C, +25°C, and +125°C. AI units are tested only at +25°C although performance at -25°C and +85°C is guaranteed to be better than or equal to the performance of A8 units over their temperature range.

**\*note 2:** The output amplitude used in testing is 0.63V<sub>pp</sub>. Performance is guaranteed for conditions listed.

**\*note 3:** In the non-inverting configuration, care should be taken when choosing R<sub>i</sub>, the input impedance setting resistor; bias currents of typically 5 $\mu A$  but as high as 24 $\mu A$  can create an input signal large enough to cause overload. It is therefore recommended that  $R_i < (V_{cc}/A_v)/24\mu A$ .

**\*note 4:** These ratings protect against damage to the input stage caused by saturation of either the input or output stages at lower supply voltages, and against exceeding transistor collector-emitter breakdown ratings at high supply voltages.  $V_{out(max)}$  is calculated by assuming no output saturation. Saturation is allowed to occur up to this calculated level of  $V_{out}$ .  $V_{cm}$  is defined as the voltage at the non-inverting input, pin 6.

# CLC231 Typical Performance Characteristics ( $T_A = 25^\circ$ , $A_v = +2$ , $V_{CC} = \pm 15V$ , $R_L = 100\Omega$ ; unless specified)

**Non-inverting Gain and Phase**

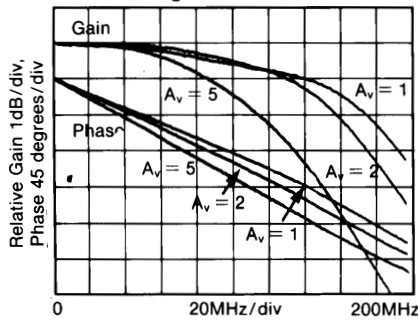

**Inverting Gain and Phase**

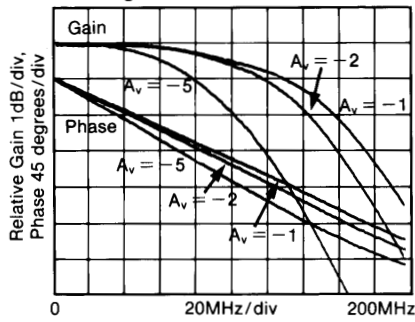

**Broadband Gain and Phase**

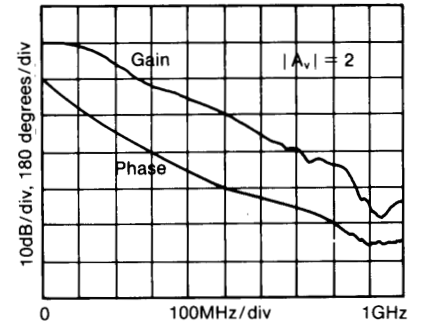

**Bandwidth vs.  $V_{CC}$**

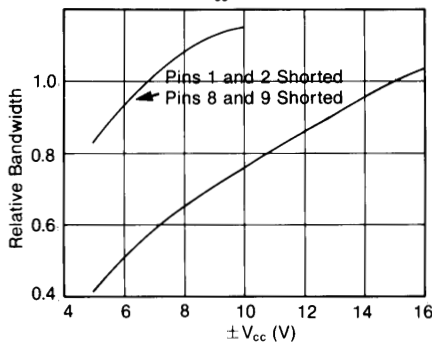

**Gain vs. Frequency for Various  $R_L$ s**

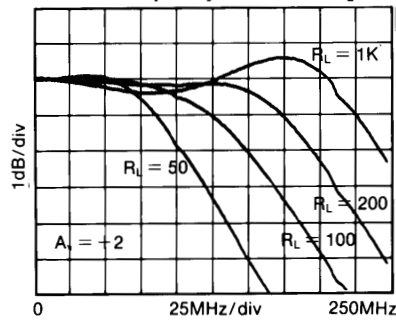

**Full Power Gain vs. Frequency**

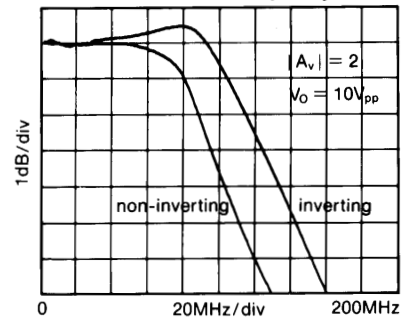

**2nd and 3rd Harmonic Distortion Intercept**

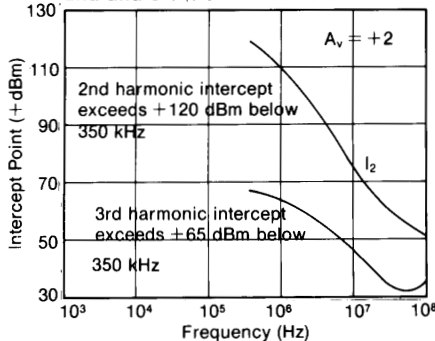

**2-Tone 3rd Order Intermod. Intercept**

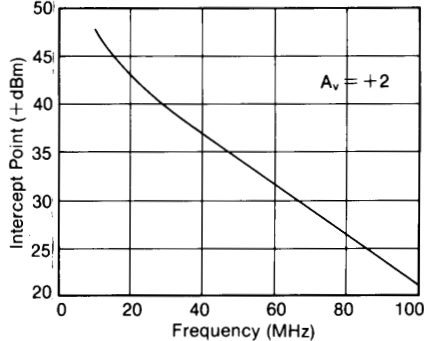

**Equivalent Input Noise**

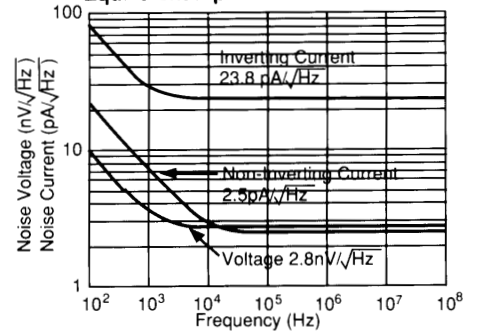

**Small Signal Pulse Response (Inv, Non-Inv)**

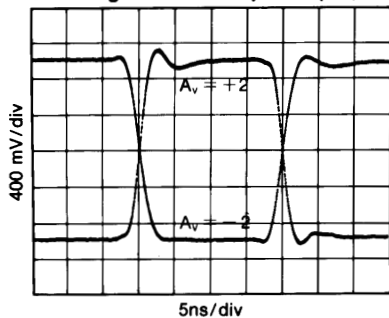

**Large Signal Pulse Response (Inv, Non-Inv)**

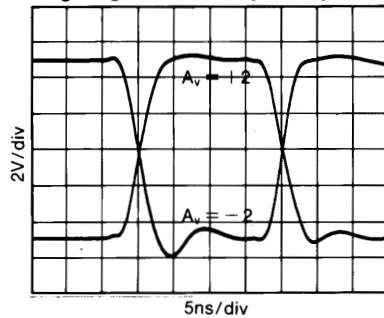

**Settling Time**

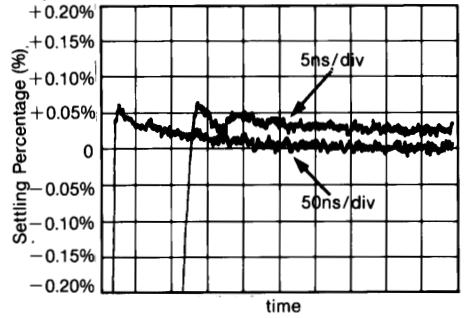

**CMRR and PSRR**

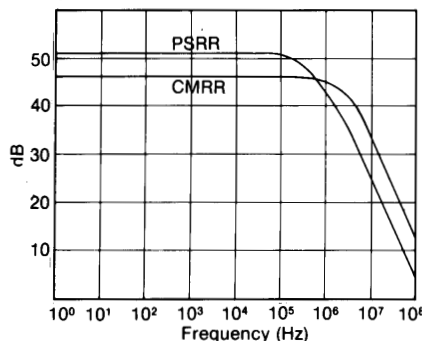

**Thermal Model**

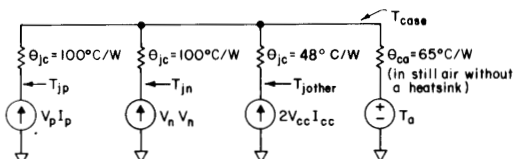

$P_{circuit} = I_{cc} [(+V_{cc}) - (-V_{cc})]$  where  $I_{cc} = 16mA$  at  $\pm 15V$   
 $P_{xxx} = [(\pm V_{cc}) - V_{out} - (I_{col})(R_{col} + 4)] (I_{col})$  (% duty cycle)  
 (For positive  $V_o$  and  $V_{cc}$ , this is the power in the npn output stage.)  
 (For negative  $V_o$  and  $V_{cc}$ , this is the power in the pnp output stage.)

$I_{col} = V_{out}/R_{load}$  or 4mA, whichever is greater. (Include feedback R in  $R_{load}$ .)  
 $R_{col}$  is a resistor (33 $\Omega$  recommended) between the xxx collector and  $\pm V_{cc}$ .  
 $T_j (pnp) = P_{pnp} (100 + \theta_{ca}) + (P_{cir} + P_{pnp}) \theta_{ca} + T_a$ , similar for  $T_j (nnp)$ .  
 $T_j (cir) = P_{cir} (48 + \theta_{ca}) + (P_{pnp} + P_{nnp}) \theta_{ca} + T_a$ .

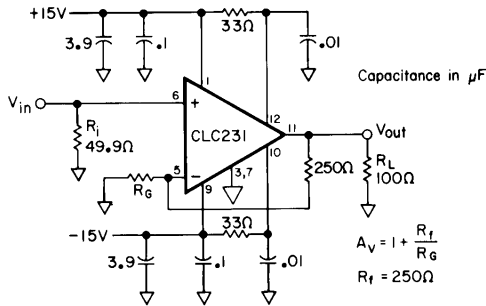

Figure 1: suggested non-inverting gain circuit

Test fixture schematics are available upon request.

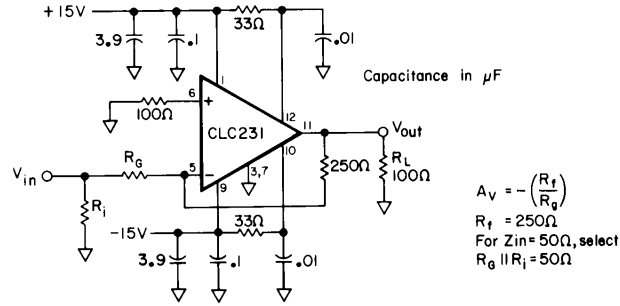

Figure 2: suggested inverting gain circuit

### CLC231 Operation

The CLC231 Buff-Amp™ is based on Comlinear's proprietary op amp topology, a design that uses current feedback instead of the usual voltage feedback. A complete discussion of current feedback is given in application note AN300-1.

The use of the CLC231 is basically the same as that of the conventional op amp (see the gain equations above). Since the device is designed specifically for low gain applications, the best performance is obtained when the circuit is used at gains between  $\pm 1$  and  $\pm 5$ . Additionally, performance is optimum when a 250Ω feedback resistor is used.

### Layout Considerations

To assure optimum performance the user should follow good layout practices which minimize the unwanted coupling of signals between nodes. During initial breadboarding of the circuit, use direct point to point wiring, keeping the lead lengths to less than .25". The use of solid, unbroken ground plane is helpful. Avoid wire-wrap type pc boards and methods. Sockets with small, short pin receptacles may be used with minimal performance degradation although their use is not recommended.

During pc board layout, keep all traces short and direct. The resistive body of  $R_g$  should be as close as possible to pin 5 to minimize capacitance at that point. For the same reason, remove ground plane from the vicinity of pins 5 and 6. In other areas, use as much ground plane as possible on one side of the board. It is especially important to provide a ground return path for current from the load resistor to the power supply bypass capacitors. Ceramic capacitors of .01 to .1μF (with short leads) should be less than .15 inches from pins 1 and 9. Larger tantalum capacitors should be placed within one inch of these pins.  $V_{cc}$  connections to pins 10 and 12 can be made directly from pins 9 and 1, but better supply rejection and settling time are obtained if they are separately bypassed as in figures 1 and 2. To prevent signal distortion caused by reflections from impedance mismatches, use terminated microstrip or coaxial cable when the signal must traverse more than a few inches.

Since the pc board forms such an important part of the circuit, much time can be saved if prototype boards of any high frequency sections are built and tested early in the design phase. Evaluation boards designed for either inverting or non-inverting gains are available from Comlinear at minimal cost.

### Thermal Considerations

At high ambient temperatures or large internal power dissipations, heat sinking is required to maintain acceptable junction temperatures. Use the thermal model on the previous page to determine junction temperatures. Many styles of heat sinks are available for TO-8 packages; the Thermalloy 2240 and 2268 are good examples. Some heat sinks are the radial fin type which cover the pc board and may interfere with external components. An excellent solution to this problem is to use surface mounted resistors and capacitors. They have a very low profile and actually improve high frequency performance. For use of these

heat sinks with conventional components, a .1" high spacer can be inserted under the TO-8 package to allow sufficient clearance.

### Low $V_{cc}$ Operation: Supply Current Adjustment

The CLC231 is designed to operate on supplies as low as  $\pm 5V$ . In order to improve full bandwidth at reduced supply voltages, the supply current ( $I_{cc}$ ) must be increased. The plot of Bandwidth vs  $V_{cc}$  shows the effect of shorting pins 1 and 2 and pins 8 and 9; this will increase both bandwidth and supply current. Care should be taken to not exceed the maximum junction temperatures; for this reason this technique should not be used with supplies exceeding  $\pm 10V$ . For intermediate values of  $V_{cc}$ , external resistors between pins 1 and 2 and pins 8 and 9 can be used.

### Offset Voltage Adjustment

If trimming of the input offset voltage ( $V_{os} = V_{ni} - V_{in}$ ) is desired, a resistor value of 10kΩ to 1MΩ placed between pins 8 and 9 will cause  $V_{os}$  to become more negative by 8mV to 0.2mV respectively. Similarly, a resistor placed between pins 1 and 2 will cause  $V_{os}$  to become more positive.

### Distortion and Noise

The graphs of intercept point,  $I_2$  and  $I_3$ , versus frequency on the preceding page make it easy to predict the distortion at any frequency given the output voltage of the CLC231. First, convert the output voltage ( $V_o$ ) to  $V_{RMS} = (V_{pp}/2\sqrt{2})$  and then to  $P = [(10\log_{10}(20V_{RMS}^2))]$  to get the power output in dBm. At the frequency of interest, its 2nd harmonic will be  $S_2 = (I_2 - P)$  dB below the level of P. Its third harmonic will be  $S_3 = 2(I_3 - P)$  dB below P, as will the two-tone third order intermodulation products. These approximations are useful for  $P < -1$  dB compression levels.

Approximate noise figure can be determined for the CLC231 using the equivalent input noise graph on the preceding page. The following equation can be used to determine noise figure (F) in dB.

$$F = 10\log \left[ 1 + \frac{v_n^2 + \frac{i_n^2 R_F^2}{A_v^2}}{4kTR_s\Delta f} \right]$$

Where  $v_n$  is the rms noise voltage and  $i_n$  is the rms noise current. Beyond the breakpoint of the curves (i.e., where they are flat), broadband noise figure equals spot noise figure, so  $\Delta f$  should equal one (1) and  $v_n$  and  $i_n$  should be read directly off the graph. Below the breakpoint, the noise must be integrated and  $\Delta f$  set to the appropriate bandwidth.

### Application Notes and Assistance

Application notes that address topics such as data conversion, fiber optics, and general high frequency circuit design are available from Comlinear or your Comlinear sales engineer.

Comlinear maintains a staff of highly qualified applications engineers to provide technical and design assistance.

**This page intentionally left blank.**

# Comlinear CLC231 Fast Settling, Wideband Buff-Amp™ ( $A_V = \pm 1$ to $\pm 5$ )

---

## Customer Design Applications Support

National Semiconductor is committed to design excellence. For sales, literature and technical support, call the National Semiconductor Customer Response Group at **1-800-272-9959** or fax **1-800-737-7018**.

## Life Support Policy

National's products are not authorized for use as critical components in life support devices or systems without the express written approval of the president of National Semiconductor Corporation. As used herein:

1. Life support devices or systems are devices or systems which, a) are intended for surgical implant into the body, or b) support or sustain life, and whose failure to perform, when properly used in accordance with instructions for use provided in the labeling, can be reasonably expected to result in a significant injury to the user.
2. A critical component is any component of a life support device or system whose failure to perform can be reasonably expected to cause the failure of the life support device or system, or to affect its safety or effectiveness.



### National Semiconductor Corporation

1111 West Bardin Road  
Arlington, TX 76017  
Tel: 1(800) 272-9959  
Fax: 1(800) 737-7018

### National Semiconductor Europe

Fax: (+49) 0-180-530 85 86  
E-mail: europe.support.nsc.com  
Deutsch Tel: (+49) 0-180-530 85 85  
English Tel: (+49) 0-180-532 78 32  
Francais Tel: (+49) 0-180-532 93 58  
Italiano Tel: (+49) 0-180-534 16 80

### National Semiconductor Hong Kong Ltd.

13th Floor, Straight Block  
Ocean Centre, 5 Canton Road  
Tsimshatsui, Kowloon  
Hong Kong  
Tel: (852) 2737-1600  
Fax: (852) 2736-9960

### National Semiconductor Japan Ltd.

Tel: 81-043-299-2309  
Fax: 81-043-299-2408