



TDA9109A

LOW-COST I²C CONTROLLED DEFLECTION PROCESSOR FOR MULTISYNC MONITOR

FEATURES

General

- SYNC PROCESSOR
- 12V SUPPLY VOLTAGE
- 8V REFERENCE VOLTAGE
- HORIZONTAL LOCK/UNLOCK OUTPUT
- READ/WRITE I²C INTERFACE
- VERTICAL MOIRE
- B+ REGULATOR
 - Internal PWM generator for B+ current mode step-up converter
 - Switchable to step-down converter
 - I²C adjustable B+ reference voltage
 - Output Pulses Synchronized on Horizontal Frequency
 - Internal Maximum Current Limitation

Horizontal

- Self-adaptative
- Dual PLL concept
- 150kHz maximum frequency
- X-ray protection input
- I²C controls:
 - Horizontal duty-cycle, H-position

Vertical

- Vertical ramp generator
- 50 to 185Hz AGC loop
- Geometry tracking with Vpos & Vamp
- I²C controls:
 - Vamp, Vpos, S-corr, C-corr
- DC breathing compensation

I²C Geometry corrections

- Vertical parabola generator (Pin Cushion - E/W, Keystone, Corner Correction)
- Horizontal dynamic phase (Side Pin Balance & Parallelogram)
- Horizontal and vertical dynamic focus (Horizontal focus amplitude, Horizontal focus symmetry, Vertical focus amplitude)

DESCRIPTION

The TDA9109A is a monolithic integrated circuit assembled in a 32-pin shrink dual in line plastic package. This IC controls all the functions related to the horizontal and vertical deflection in multi-mode or multi-frequency computer display monitors.

The internal sync processor, combined with the very powerful geometry correction block, make the TDA9109A suitable for very high performance monitors, using very few external components.

The horizontal jitter level is very low. It is particularly well-suited to high-end 15" and 17" monitors.

Combined with the ST7275 Microcontroller family, TDA9206 (Video preamplifier) and STV942x (On-Screen Display controller), the TDA9109A allows fully I²C bus-controlled computer display monitors to be built with a reduced number of external components



TABLE OF CONTENTS

PIN CONNECTIONS	4
PIN CONNECTIONS	5
QUICK REFERENCE DATA	6
BLOCK DIAGRAM	8
ABSOLUTE MAXIMUM RATINGS	9
THERMAL DATA	9
I²C READ/WRITE	10
SYNC PROCESSOR	10
HORIZONTAL SECTION	11
VERTICAL SECTION	13
DYNAMIC FOCUS SECTION	15
GEOMETRY CONTROL SECTION	16
B+ SECTION	18
TYPICAL OUTPUT WAVEFORMS	20
I²C BUS ADDRESS TABLE	24
I²C BUS ADDRESS TABLE	25
OPERATING DESCRIPTION	27
1 GENERAL CONSIDERATIONS	27
1.1 Power Supply	27
1.2 I ² C Control	27
1.3 Write Mode	27
1.4 Read Mode	27
1.5 Sync Processor	27
1.6 Sync Identification Status	28
1.7 IC status	28
1.8 Sync Inputs	28
1.9 Sync Processor Output	28
2 HORIZONTAL PART	28
2.1 Internal Input Conditions	28
2.2 PLL1	29
2.3 PLL2	31
2.4 Output Section	32
2.5 X-RAY Protection	32
2.6 Horizontal and Vertical Dynamic Focus	33
3 VERTICAL PART	34
3.1 Function	34
3.2 I ² C Control Adjustments	34
3.3 Vertical Moiré	34
3.4 Basic Equations	35
3.5 E/W	36
3.6 Dynamic Horizontal Phase Control	36

TABLE OF CONTENTS

4 DC/DC CONVERTER PART	37
4.1 Step-up Mode	37
4.2 Step-down Mode	37
4.3 Step-up and Step-down Mode Comparison	37
INTERNAL SCHEMATICS	39
PACKAGE MECHANICAL DATA	46

PIN CONNECTIONS

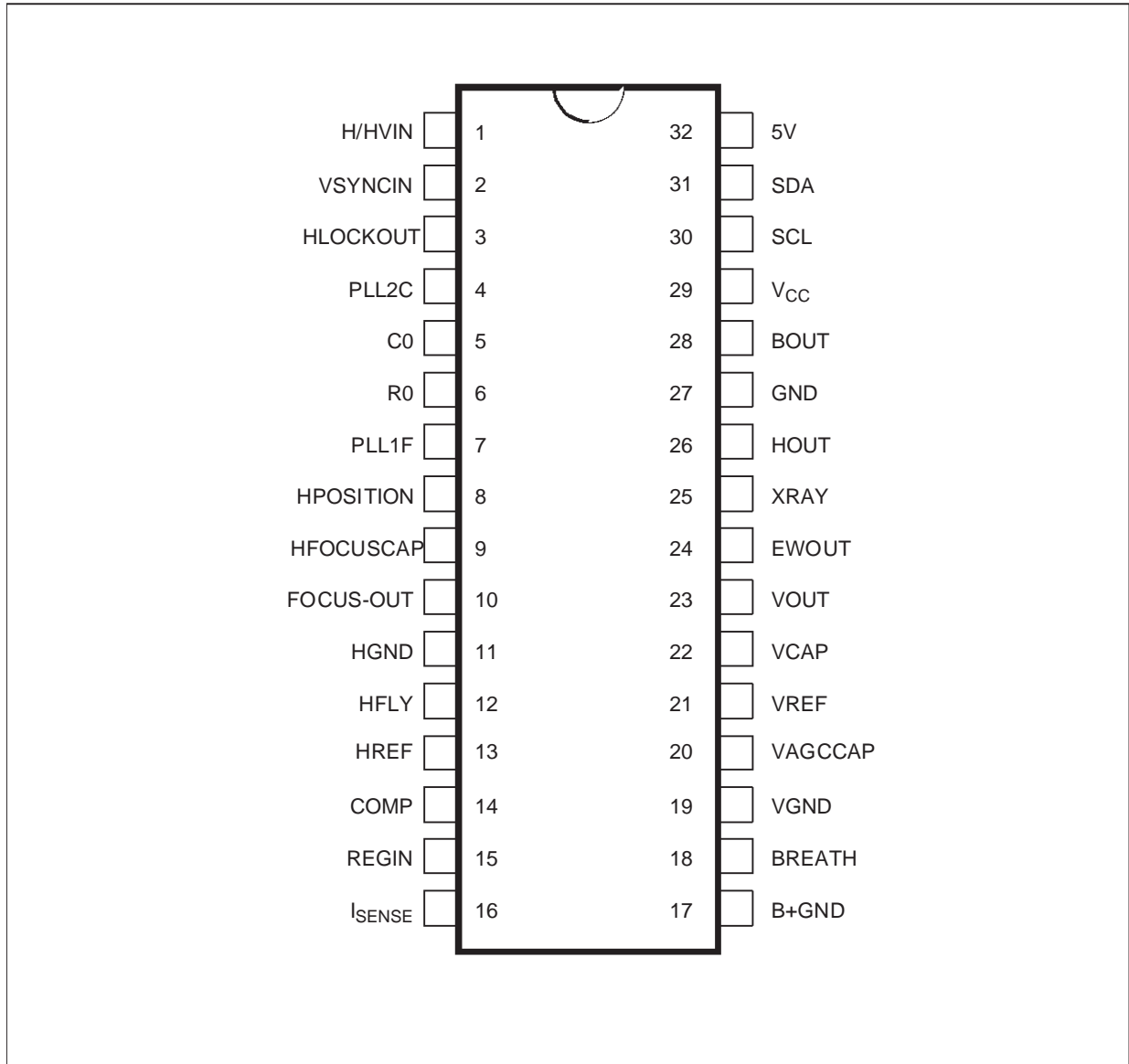

PIN CONNECTIONS

Pin	Name	Function
1	H/HVIN	TTL compatible Horizontal sync Input (separate or composite)
2	VSYNCIN	TTL compatible Vertical sync Input (for separated H&V)
3	HLOCKOUT	First PLL Lock/Unlock Output (0 V: Unlocked - 5 V: Locked)
4	PLL2C	Second PLL Loop Filter
5	C0	Horizontal Oscillator Capacitor
6	R0	Horizontal Oscillator Resistor
7	PLL1F	First PLL Loop Filter
8	HPOSITION	Horizontal Position Filter (capacitor to be connected to HGND)
9	HFOCUSCAP	Horizontal Dynamic Focus Oscillator Capacitor
10	FOCUS OUT	Mixed Horizontal and Vertical Dynamic Focus Output
11	HGND	Horizontal Section Ground
12	HFLY	Horizontal Flyback Input (positive polarity)
13	HREF	Horizontal Section Reference Voltage (to be filtered)
14	COMP	B+ Error Amplifier Output for frequency compensation and gain setting
15	REGIN	Regulation Input of B+ control loop
16	I _{SENSE}	Sensing of external B+ switching transistor current, or switch for step-down converter
17	B+GND	Ground (related to B+ reference adjustment)
18	BREATH	DC Breathing Input Control (compensation of vertical amplitude against EHV variation)
19	VGND	Vertical Section Ground
20	VAGCCAP	Memory Capacitor for Automatic Gain Control Loop in Vertical Ramp Generator
21	V _{REF}	Vertical Section Reference Voltage (to be filtered)
22	VCAP	Vertical Sawtooth Generator Capacitor
23	VOUT	Vertical Ramp Output (with frequency independent amplitude and S or C Corrections if any). It is mixed with vertical position voltage and vertical moiré.
24	EWOUT	Pin Cushion - E/W Correction Parabola Output
25	XRAY	X-RAY protection input (with internal latch function)
26	HOUT	Horizontal Drive Output (NPN open collector)
27	GND	General Ground (referenced to V _{CC})
28	BOUT	B+ PWM Regulator Output
29	V _{CC}	Supply Voltage (12V typ)
30	SCL	I ² C Clock Input
31	SDA	I ² C Data Input
32	5V	Supply Voltage (5V typ.)

QUICK REFERENCE DATA

Parameter	Value	Unit
Horizontal Frequency	15 to 150	kHz
Autosynch Frequency (for given R0 and C0. Can be easily increased by application)	1 to 4.5 f0	
± Horizontal Sync Polarity Input	YES	
Polarity Detection (on both Horizontal and Vertical Sections)	YES	
TTL Composite Sync	YES	
Lock/Unlock Identification (on both Horizontal 1st PLL and Vertical Section)	YES	
I ² C Control for H-Position	±10	%
XRAY Protection	YES	
I ² C Horizontal Duty Cycle Adjustment	30 to 65	%
I ² C Free Running Frequency Adjustment	NO	
Stand-by Function	YES	
Dual Polarity H-Drive Outputs	NO	
Supply Voltage Monitoring	YES	
PLL1 Inhibition Possibility	NO	
Blanking Outputs	NO	
Vertical Frequency	35 to 200	Hz
Vertical Autosync (for 150nF on Pin 22 and 470nF on Pin 20)	50 to 185	Hz
Vertical S-Correction (optimized for super flat tube)	YES	
Vertical C-Correction	YES	
Vertical Amplitude Adjustment	YES	
DC Breathing Control on Vertical Amplitude	YES	
Vertical Position Adjustment	YES	
East/West (E/W) Parabola Output (also known as Pin Cushion Output)	YES	
E/W Correction Amplitude Adjustment	YES	
Keystone Adjustment	YES	
Corner Correction with Amplitude Adjustment	YES	
Internal Dynamic Horizontal Phase Control	YES	
Side Pin Balance Amplitude Adjustment	YES	
Parallelogram Adjustment	YES	
Tracking of Geometric Corrections with Vertical Amplitude and Position	YES	
Reference Voltage (both on Horizontal and Vertical)	YES	
Dynamic Focus (both Horizontal and Vertical)	YES	
I ² C Horizontal Dynamic Focus Amplitude Adjustment	YES	
I ² C Horizontal Dynamic Focus Symmetry Adjustment	YES	
I ² C Vertical Dynamic Focus Amplitude Adjustment	YES	

Parameter	Value	Unit
Detection of Input Sync (biased from 5V alone)	YES	
Vertical Moiré	YES	
Controlled V-Moiré Amplitude	YES	
Frequency Generator for Burn-in	NO	
Fast I ² C Read/Write	400	kHz
B+ Regulation adjustable by I ² C	YES	
Horizontal Size Control	NO	

BLOCK DIAGRAM

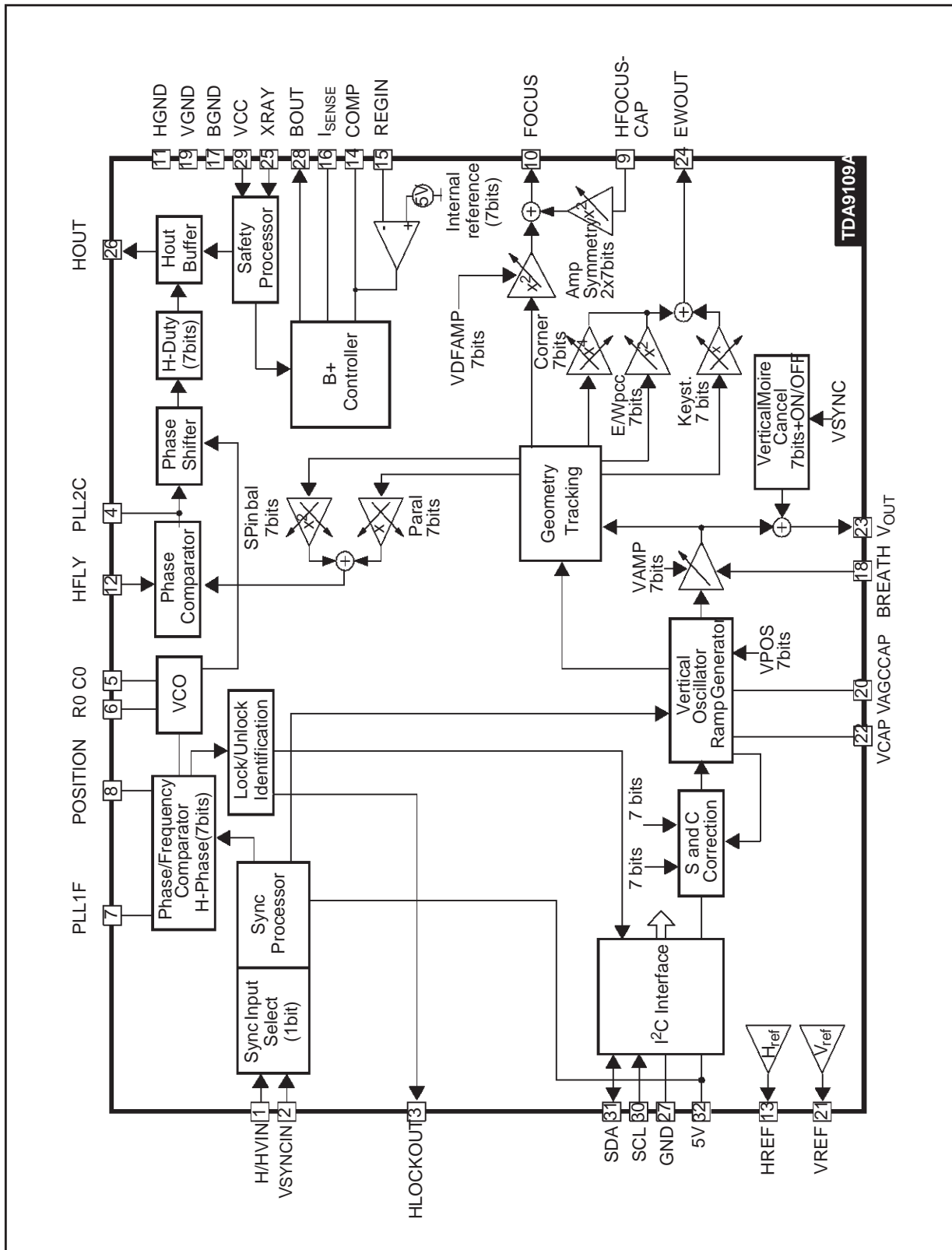

ABSOLUTE MAXIMUM RATINGS

Symbol	Parameter	Value	Unit
V_{CC}	Supply Voltage (Pin 29)	13.5	V
V_{DD}	Supply Voltage (Pin 32)	5.7	V
V_{IN}	Max Voltage on Pin 4	4.0	V
	Pin 9	5.5	V
	Pin 5	6.4	V
	Pins 6, 7, 8, 14, 15, 16, 20, 22	8.0	V
	Pins 10, 18, 23, 24, 25, 26, 28	V_{CC}	V
	Pins 1, 2, 3, 30, 31	V_{DD}	V
$VESD$	ESD susceptibility through	Human Body Model, 100pF Discharge 1.5k Ω	2 kV
		EIAJ Norm, 200pF Discharge through 0 Ω	300 V
T_{stg}	Storage Temperature	-40, +150	$^{\circ}C$
T_j	Junction Temperature	+150	$^{\circ}C$
T_{oper}	Operating Temperature	0, +70	$^{\circ}C$

THERMAL DATA

Symbol	Parameter	Value	Unit
$R_{th(j-a)}$	Max. Junction-Ambient Thermal Resistance	65	$^{\circ}C/W$

I²C READ/WRITE

Electrical Characteristics ($V_{DD} = 5V$, $T_{amb} = 25^{\circ}C$)

Symbol	Parameter	Test Conditions	Min.	Typ.	Max.	Units
I²C PROCESSOR (See ¹)						
Fscl	Maximum Clock Frequency	Pin 30			400	kHz
Tlow	Low period of the SCL Clock	Pin 30	1.3			μs
Thigh	High period of the SCL Clock	Pin 30	0.6			μs
Vinth	SDA and SCL Input Threshold	Pins 30, 31		2.2		V
VACK	Acknowledge Output Voltage on SDA input with 3mA	Pin 31			0.4	V
I ² C leak	Leakage current into SDA and SCL with no logic supply	$V_{DD} = 0$ Pins 30, 31 = 5 V			20	μA

Note: 1 See also I²C Bus Address Table.

SYNC PROCESSOR

Operating Conditions ($V_{DD} = 5V$, $T_{amb} = 25^{\circ}C$)

Symbol	Parameter	Test Conditions	Min.	Typ.	Max.	Units
HsVR	Voltage on H/HVIN Input	Pin 1	0		5	V
MinD	Minimum Horizontal Input Pulses Duration	Pin 1	0.7			μs
Mduty	Maximum Horizontal Input Signal Duty Cycle	Pin 1			25	%
VsVR	Voltage on VSYNCIN	Pin 2	0		5	V
VSW	Minimum Vertical Sync Pulse Width	Pin 2	5			μs
VSmD	Maximum Vertical Sync Input Duty Cycle	Pin 2			15	%
VextM	Maximum Vertical Sync Width on TTL H/Vcomposite	Pin 1			750	μs

Electrical Characteristics ($V_{DD} = 5V$, $T_{amb} = 25^{\circ}C$)

Symbol	Parameter	Test Conditions	Min.	Typ.	Max.	Units
VINTH	Horizontal and Vertical Input Logic Level (Pins 1, 2)	High Level Low Level	2.2		0.8	V V
RIN	Horizontal and Vertical Pull-Up Resistor	Pins 1, 2		250		k Ω
VoutT	Extracted Vsync Integration Time (% of T_H) on H/V Composite (see ²)	$C_0 = 820pF$	26	35		%

Note: 2 T_H is the Horizontal period.

HORIZONTAL SECTION

Operating Conditions

Symbol	Parameter	Test Conditions	Min.	Typ.	Max.	Units
VCO						
I_{0max}	Max Current from Pin 6	Pin 6			1.5	mA
F(max.)	Maximum Oscillator Frequency				150	kHz
OUTPUT SECTION						
I12m	Maximum Input Peak Current	Pin 12			5	mA
HOI	Horizontal Drive Output Maximum Current	Pin 26, Sunk current			30	mA

Electrical Characteristics ($V_{DD} = 12V$, $T_{amb} = 25^{\circ}C$)

Symbol	Parameter	Test Conditions	Min.	Typ.	Max.	Units
SUPPLY AND REFERENCE VOLTAGES						
V_{CC}	Supply Voltage	Pin 29	10.8	12	13.2	V
V_{DD}	Supply Voltage	Pin 32	4.5	5	5.5	V
I_{CC}	Supply Current	Pin 29		50		mA
I_{DD}	Supply Current	Pin 32		5		mA
V_{REF-H}	Horizontal Reference Voltage	Pin 13, $I = -2mA$	7.6	8.2	8.8	V
V_{REF-V}	Vertical Reference Voltage	Pin 21, $I = -2mA$	7.6	8.2	8.8	V
I_{REF-H}	Max. Sourced Current on V_{REF-H}	Pin 13			5	mA
I_{REF-V}	Max. Sourced Current on V_{REF-V}	Pin 21			5	mA
1st PLL SECTION						
HpolT	Delay Time for detecting polarity change (see ³)	Pin 1	0.75			ms
Vvco	VCO Control Voltage (Pin 7)	$V_{REF-H} = 8.2V$ $f_H(\text{Max.})$		1.4 6.4		V V
Vcog	VCO Gain (Pin 7)	$R_0 = 6.49k\Omega$, $C_0 = 820pF$		15.9		kHz/V
Hph	Horizontal Phase Adjustment (see ⁴)	% of Horizontal Period		± 10		%
Vbmi Vbtyp Vbmax	Horizontal Phase Setting Value (Pin 8) (see ⁴) Minimum Value Typical Value Maximum Value	Sub-Address 01 Byte x11111111 Byte x10000000 Byte x00000000		2.9 3.5 4.2		V V V
IP111U IP111L	PLL1 Filter Current Charge	PLL1 is Unlocked PLL1 is Locked		± 140 ± 1		μA mA
f_0	Free Running Frequency	$R_0 = 6.49k\Omega$, $C_0 = 820pF$		22.8		kHz
dfo/dT	Free Running Frequency Thermal Drift (No drift on external components) (see ⁵)			-150		ppm/ C
CR	PLL1 Capture Range	$f_H(\text{Min.})$ $f_H(\text{Max.})$ (See Note 6)		$f_0 + 0.5$ $4.5f_0$		kHz kHz
HUnlock	DC level pin 3 when PLL1 is locked			5		V

TDA9109A

Symbol	Parameter	Test Conditions	Min.	Typ.	Max.	Units
2nd PLL SECTION AND HORIZONTAL OUTPUT SECTION						
FBth	Flyback Input Threshold Voltage (Pin 12)		0.65	0.75		V
Hjit	Horizontal Jitter (See 7)	At 31.4kHz		70		ppm
HDmin HDmax	Horizontal Drive Output Duty-Cycle (Pin 26) (see 8)	Sub-Address 00 Byte x11111111 Byte x00000000 (see 9)		30 65		% %
XRAYth	X-RAY Protection Input Threshold Voltage,	Pin 25, see Figure 14	7.6	8.2	8.8	V
Vphi2	Internal Clamping Levels on 2nd PLL Loop Filter (Pin 4)	Low Level High Level		1.6 4.2		V V
VSCinh	Threshold Voltage to Stop H-Out, V-Out, B-Out and Reset XRAY when $V_{CC} < V_{SCinh}$ (see Figure14)	Pin 29		7.5		V
HDvd	Horizontal Drive Output (low level)	Pin 26, $I_{OUT} = 30mA$			0.4	V

Note: 3 This delay is mandatory to avoid a wrong detection of polarity change in the case of a composite sync.

Note: 4 See Figure 10 for explanation of reference phase.

Note: 5 These parameters are not tested on each unit. They are measured during our internal qualification.

Note: 6 A larger range may be obtained by application.

Note: 7 $Hjit = 10^6 \times$ (Standard deviation/Horizontal period)

Note: 8 Duty Cycle is the ratio between the output transistor OFF time and the period. The power transistor is controlled OFF when the output transistor is OFF.

Note: 9 Initial Condition for Safe Operation Start Up.

VERTICAL SECTION

Operating Conditions

Symbol	Parameter	Test Conditions	Min.	Typ.	Max.	Units
OUTPUTS SECTION						
R _{LOAD}	Minimum Load for less than 1% Vertical Amplitude Drift	Pin 20	65			MΩ

Electrical Characteristics (V_{CC} = 12V, T_{amb} = 25°C)

Symbol	Parameter	Test Conditions	Min.	Typ.	Max.	Units
VERTICAL RAMP SECTION						
VRB	Voltage at Ramp Bottom Point	Pin 22		2.1		V
VRT	Voltage at Ramp Top Point (with Sync)	Pin 22		5.1		V
VRTF	Voltage at Ramp Top Point (without Sync)	Pin 22		VRT-0.1		V
VSTD	Vertical Sawtooth Discharge Time	Pin 22, C ₂₂ = 150nF		70		μs
VFRF	Vertical Free Running Frequency (See ¹¹)	C ₂₂ = 150nF		100		Hz
ASFR	AUTO-SYNC Frequency (See ¹²)	C ₂₂ = 150nF ±5%	50		185	Hz
RAFD	Ramp Amplitude Drift Versus Frequency at Maximum Vertical Amplitude (see ¹⁰)	C ₂₂ = 150nF 50Hz < f < 185Hz		200		ppm/Hz
Rlin	Ramp Linearity on Pin 22 (See ¹¹)	2.5V < V ₂₇ < 4.5V		0.5		%
VPOS	Vertical Position Adjustment Voltage (Pin 23 - VOUT mean value)	Sub Address 06 Byte 00000000 Byte 01000000 Byte 01111111		3.2 3.6 4.0		V V V
VOR	Vertical Output Voltage (peak-to-peak on Pin 23)	Sub Address 05 Byte 10000000 Byte 11000000 Byte 11111111		2.15 3.0 3.9		V V V
VOI	Vertical Output Maximum Current (Pin 23)			±5		mA
dVS	Max Vertical S-Correction Amplitude (See ¹³) 0xxxxxxx inhibits S-CORR 11111111 gives max S-CORR	Sub Address 07 Byte 11111111 ΔV/V _{PP} at TV/4 ΔV/V _{PP} at 3TV/4		-3.5 3.5		% %
Ccorr	Vertical C-Corr Amplitude 0xxxxxxx inhibits C-CORR	Sub Address 08 ΔV/V _{PP} at TV/2 Byte 10000000 Byte 11000000 Byte 11111111		-3 0 3		% % %
VMOIRE	Vertical Moiré	Sub Address 0C Byte 01X11111		6		mV

TDA9109A

Symbol	Parameter	Test Conditions	Min.	Typ.	Max.	Units
BREATHING COMPENSATION						
BRRANG	DC Breathing Voltage Range (See 14)	V_{18}	1		12	V
BRADj	Vertical Output Variation versus DC Breathing Control (Pin 23)	$V_{18} \geq V_{REF-V}$ $1V < V_{18} < V_{REF-V}$		0 -2.5		%/V %/V

Note: 10 These parameters are not tested on each unit. They are measured during our internal qualification procedure.

Note: 11 With Register 07 at Byte 0xxxxxxx (S correction is inhibited) and Register 08 at Byte 0xxxxxxx (C correction is inhibited), the vertical sawtooth has a linear shape.

Note: 12 This is the frequency range for which the vertical oscillator will automatically synchronize, using a single capacitor value on Pin22 and Pin 20, and with a constant ramp amplitude.

Note: 13 TV is the vertical period.

Note: 14 When not used, the DC breathing control pin must be connected to 12V.

DYNAMIC FOCUS SECTION

Electrical Characteristics ($V_{CC} = 12V$, $T_{amb} = 25^{\circ}C$)

Symbol	Parameter	Test Conditions	Min.	Typ.	Max.	Units
HORIZONTAL DYNAMIC FOCUS FUNCTION						
HDFst	Horizontal Dynamic Focus Sawtooth Minimum Level Maximum Level	Pin 9, capacitor on HFOCUSCAP and $C_0 = 820pF$, $T_H = 20\mu s$		2.2 4.9		V V
HDFdis	Horizontal Dynamic Focus Sawtooth Discharge Width	Start by HDFstart		400		ns
HDFstart	Internal Fixed Phase Advance versus HFLY middle	Independent of frequency		1		μs
HDFDC	Bottom DC Output Level	$R_{LOAD} = 10k\Omega$, Pin 10		2.1		V
TDFHD	DC Output Voltage Thermal Drift (see ¹⁵)			200		ppm/C
HDFamp	Horizontal Dynamic Focus Amplitude Min Byte xxx11111 Typ Byte xxx10000 Max Byte xxx00000	Sub-Address 03, Pin 10, fH = 50kHz, Symmetric Wave Form		1 1.5 3.5		V_{PP} V_{PP} V_{PP}
HDFkeyst	Horizontal Dynamic Focus Position Advance for Byte xxx11111 Delay for Byte xxx00000	Sub-address 04 For time reference see Figure 15		16 16		% %
VERTICAL DYNAMIC FOCUS FUNCTION (positive parabola)						
AMPVDF	Vertical Dynamic Focus Parabola (added to horizontal) Amplitude with VAMP and VPOS Typical Min. Byte xx000000 Typ. Byte xx100000 Max. Byte xx111111	Sub-Address 0F		0 0.5 1		V_{PP} V_{PP} V_{PP}
VDFAMP	Parabola Amplitude Function of VAMP (tracking between VAMP and VDF) with VPOS Typ. (see Figure 1 and ¹⁶)	Sub-Address 05 Byte x0000000 Byte x1000000 Byte x1111111		0.6 1 1.5		V_{PP} V_{PP} V_{PP}
VHDFKeyt	Parabola Asymmetry Function of VPOS Control (tracking between VPOS and VDF) with VAMP Max. A/B Ratio B/A Ratio	Sub-Address 06 Byte x0000000 Byte x1111111		0.52 0.52		

Note: 15 These parameters are not tested on each unit. They are measured during our internal qualification.

Note: 16 S and C correction are inhibited so the vertical output sawtooth has a linear shape.

GEOMETRY CONTROL SECTION

Electrical Characteristics ($V_{CC} = 12V$, $T_{amb} = 25^{\circ}C$)

Symbol	Parameter	Test Conditions	Min.	Typ.	Max.	Units
East/West E/W FUNCTION						
EW_{DC}	DC Output Voltage with: - typical VPOS - Keystone inhibited	Pin 24, see Figure 2		2.5		V
$TDEW_{DC}$	DC Output Voltage Thermal Drift	See ¹⁵		100		ppm/ C
EW_{para}	Parabola Amplitude with: - Max. VAMP, - Typ. VPOS, - Keystone and Corner inhibited	Subaddress 0A Byte 11111111 Byte 11000000 Byte 10000000		2.5 1.25 0		V_{PP} V_{PP} V_{PP}
EW_{track}	Parabola Amplitude Function of VAMP Control (tracking between VAMP and E/W) with: - Typ. VPOS, - Typ. E/W Amplitude, - Corner and Keystone inhibited (¹⁷)	Subaddress 05 Byte 10000000 Byte 11000000 Byte 11111111		0.45 0.80 1.45		V_{PP} V_{PP} V_{PP}
KeyAdj	Keystone Adjustment Capability with: - - Typ. VPOS, - E/W inhibited, - Corner inhibited and - Max. Vertical Amplitude (see ¹⁷ and Figure 4)	Subaddress 09 Byte 10000000 Byte 11111111		1 1		V_{PP} V_{PP}
EW Corner	Corner Adjustment Capability with: - Typ. VPOS, - E/W inhibited, - Keystone inhibited - Max. Vertical Amplitude	Subaddress 10 Byte 11111111 Byte 11000000 Byte 10000000		+3 0 -3		V_{PP} V_{PP} V_{PP}
KeyTrack	Intrinsic Keystone Function of VPOS Control (tracking between VPOS and E/W) with: - Max. E/W Amplitude - Max. Vertical Amplitude A/B Ratio B/A Ratio	Subaddress 06 Byte 00000000 Byte 01111111		0.52 0.52		

Symbol	Parameter	Test Conditions	Min.	Typ.	Max.	Units
INTERNAL DYNAMIC HORIZONTAL PHASE CONTROL						
SPBpara	Side Pin Balance Parabola Amplitude (Figure 3) with: - Max. VAMP, - Typ. VPOS - Parallelogram inhibited (see ¹⁷ & ¹⁹)	Subaddress 0D Byte 11111111 Byte 10000000		+2.8 -2.8		%T _H %T _H
SPBtrack	Side Pin Balance Parabola Amplitude function of VAMP Control (tracking between VAMP and SPB) with - Max. SPB, - Typ. VPOS - Parallelogram inhibited (see ¹⁷ & ¹⁹)	Subaddress 05 Byte 10000000 Byte 11000000 Byte 11111111		1 1.8 2.8		%T _H %T _H %T _H
ParAdj	Parallelogram Adjustment Capability with: - Max. VAMP, - Typ. VPOS - Max. SPB (see ¹⁷ & ¹⁹)	Subaddress 0E Byte 11111111 Byte 11000000		+2.8 -2.8		%T _H %T _H
Partrack	Intrinsic Parallelogram Function of VPOS Control (tracking between VPOS and DHPC) with: - Max. VAMP, - Max. SPB - Parallelogram inhibited (see ¹⁷ & ¹⁹) A/B Ratio B/A Ratio	Subaddress 06 Byte x0000000 Byte x1111111		0.52 0.52		

Note: 17 With Register 07 at Byte 0xxxxxxx (S correction is inhibited) and Register 08 at Byte 0xxxxxxx (C correction is inhibited), the vertical sawtooth has a linear shape.

Note: 18 T_H is the horizontal period.

Note: 19 When not used, the DC breathing control pin must be connected to 12V.

B+ SECTION**Operating Conditions**

Symbol	Parameter	Test Conditions	Min.	Typ.	Max.	Units
FeedRes	Minimum Feedback Resistor	Resistor between Pins 15 and 14	5			k Ω

Electrical Characteristics ($V_{CC} = 12V$, $T_{amb} = 25^{\circ}C$)

Symbol	Parameter	Test Conditions	Min.	Typ.	Max.	Units
OLG	Error Amplifier Open Loop Gain	At low frequency (¹⁵)		85		dB
UGBW	Unity Gain Bandwidth	(see ¹⁵)		6		MHz
IRI	Regulation Input Bias Current	Current sourced by Pin 15 (PNP base)		0.2		μ A
EAOI	Error Amplifier Output Current	Current sourced by Pin 14 Current sunk by Pin 14 (See ²⁰)	2	1.4		mA
CSG	Current Sense Input Voltage Gain	Pin 16		3		
MCEth	Max Current Sense Input Threshold Voltage	Pin 16		1.3		V
ISI	Current Sense Input Bias Current	Current sunk by Pin 16 (PNP base)		1		μ A
Tonmax	Maximum ON Time of the external power transistor	% of horizontal period $f_o = 27kHz$ (See ²¹)		100		%
B+OSV	B+Output Saturation Voltage	V_{28} with $I_{28} = 10mA$		0.25		V
V_{REF}	Internal Reference Voltage	On error amp (+) input for Subaddress OB Byte 1000000		5		V
V_{REFADJ}	Internal Reference Voltage Adjustment Range	Byte 01111111 Byte 00000000		+20 -20		% %
PWMSEL	Threshold for step-up/step-down selection	Pin 16		6		V
t_{FB+}	Fall Time	Pin 28		100		ns

Note: 20 0.5mA are sunk when B+ section is disabled. the purpose is to discharge the soft-start capacitor.

Note: 21 The external power transistor is OFF during 400ns of the HFOCUSCAP discharge

Figure 1. Vertical Dynamic Focus Function

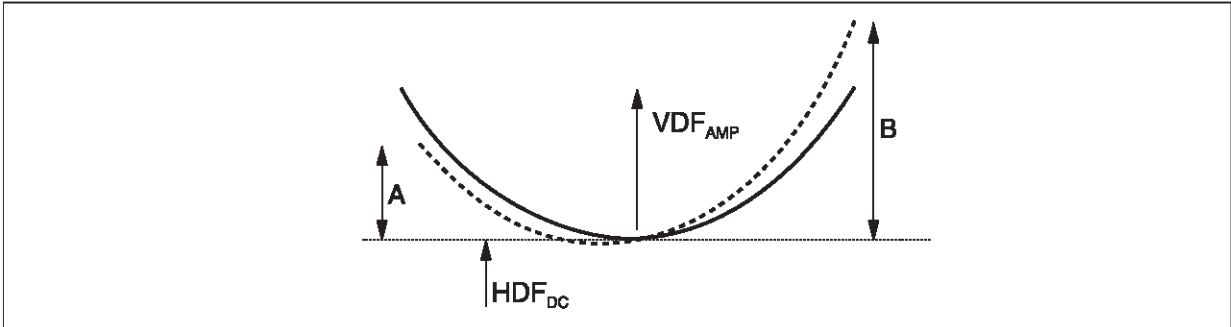

Figure 2. E/W Output

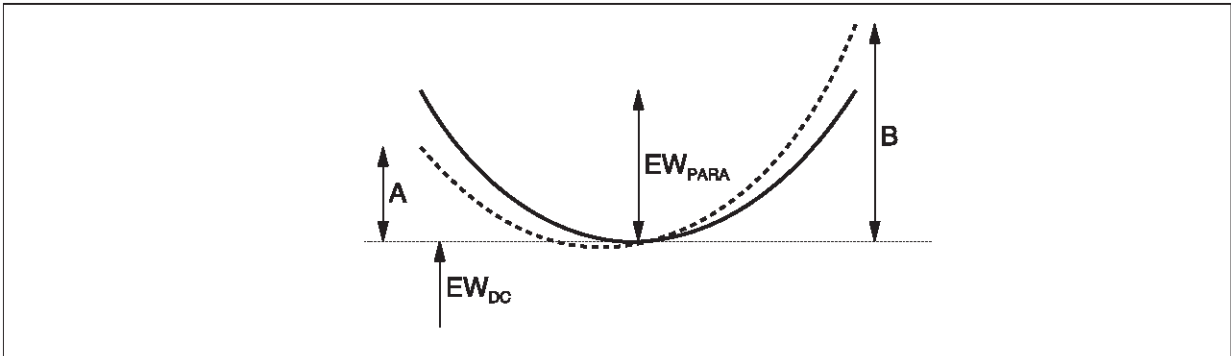

Figure 3. Dynamic Horizontal Phase Control Output

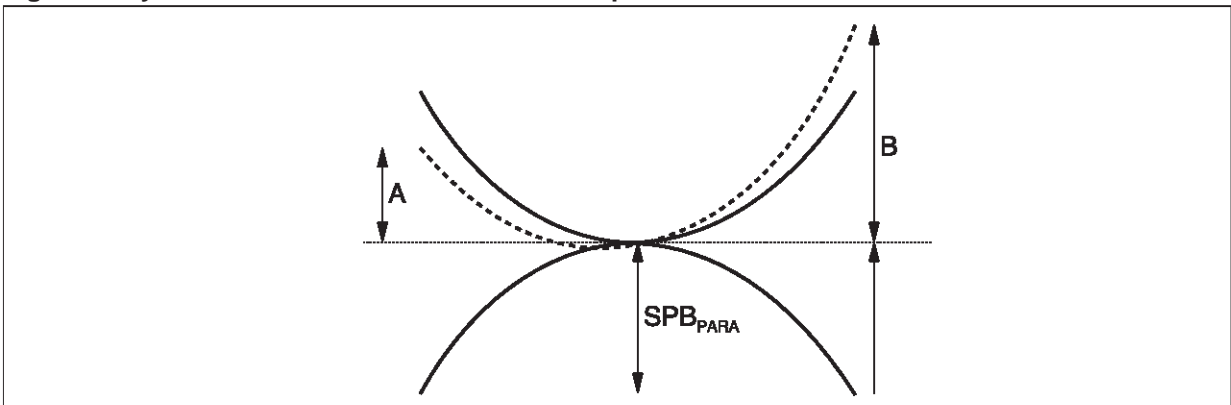
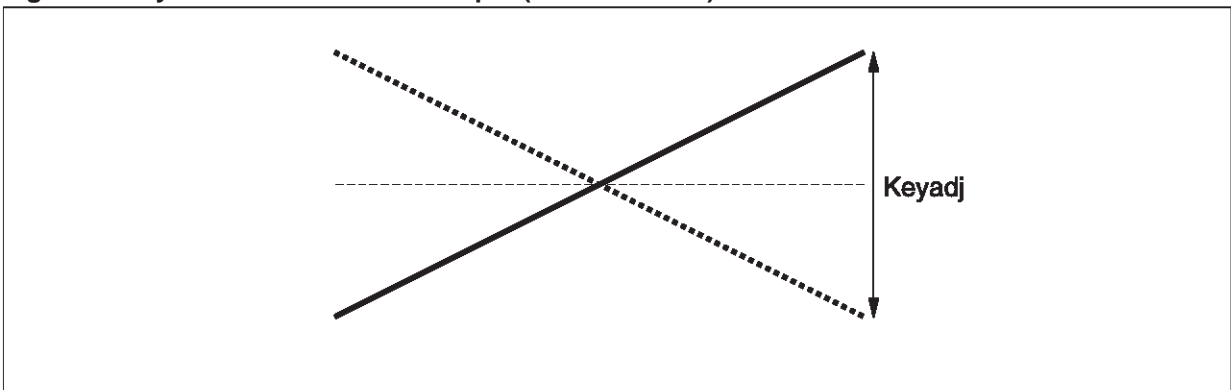
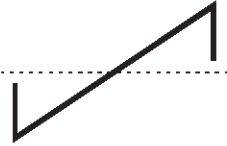
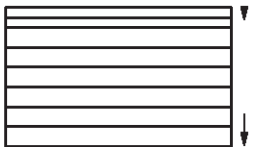
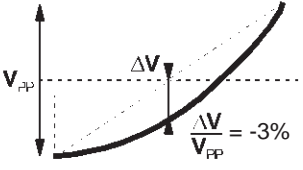
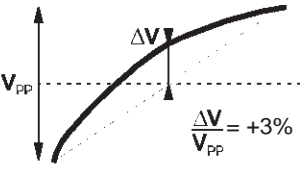
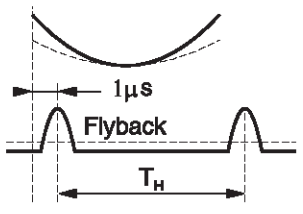
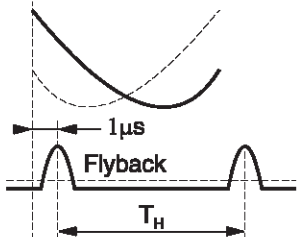

Figure 4. Keystone Effect on E/W Output (PCC Inhibited)









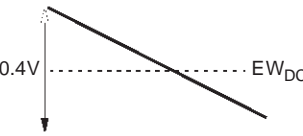
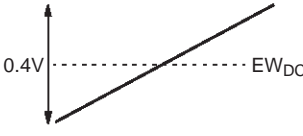

TYPICAL OUTPUT WAVEFORMS

Function	Sub Address	Pin	Byte	Specification	Effect on Screen
Vertical Size	05	23	10000000		
			11111111		
Vertical Position DC Control	06	23	00000000	$V_{OUTDC} = 3.2V$	
			01000000	$V_{OUTDC} = 3.6V$	
			01111111	$V_{OUTDC} = 4.0V$	
Vertical S Linearity	07	23	0xxxxxx: Inhibited		
			11111111		

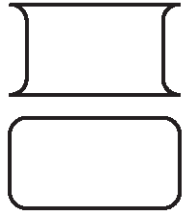
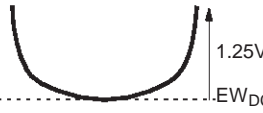
Function	Sub Address	Pin	Byte	Specification	Effect on Screen
Vertical C Linearity	08	23	0xxxxxxx : Inhibited		
			10000000		
			11111111		
Horizontal Dynamic Focus with: Ampli- tude	03	10	X000 0000 — X111 1111 - --		
Horizontal Dynamic Focus with: Symme- try	04	10	X000 0000 — X111 1111 - --		

TDA9109A

Function	Sub Address	Pin	Byte	Specification	Effect on Screen
Keystone (Trapezoid) Control	09	24	(E/W + Corner Inhibited)		
			10000000		
			11111111		
E/W (Pin Cushion) Control	0A	24	(Keystone + Corner Inhibited)		
			10000000		
			11111111		
Corner Control	10	24	(Keystone+E/W Inhibited)		
			11111111		
			10000000		
Parallelogram Control	0E	Internal	(SPB Inhibited)		
			10000000		
			11111111		

Function	Sub Address	Pin	Byte	Specification	Effect on Screen
Side Pin Balance Control	0D	Internal	(Parallelogram Inhibited)		
			10000000		
			11111111		
Vertical Dynamic Focus with Horizontal	0F	10	X111 1111 —X000 0000 ---		

I²C BUS ADDRESS TABLE**Slave Address (8C): Write Mode
Sub Address Definition**

	D8	D7	D6	D5	D4	D3	D2	D1	
0	0	0	0	0	0	0	0	0	Horizontal Drive Selection/Horizontal Duty Cycle
1	0	0	0	0	0	0	0	1	X-ray Reset/Horizontal Position
2	0	0	0	0	0	0	0	0	
3	0	-	-	1	0	0	1	1	Sync. Priority/Horizontal Focus Amplitude
4	0	-	-	1	0	1	0	0	Refresh/Horizontal Focus Keystone
5	0	0	0	0	0	1	0	1	Vertical Ramp Amplitude
6	0	0	0	0	0	1	1	0	Vertical Position Adjustment
7	0	0	0	0	0	1	1	1	S Correction
8	0	0	0	0	1	0	0	0	C Correction
9	0	0	0	0	1	0	0	1	E/W Keystone
A	0	0	0	0	1	0	1	0	E/W Amplitude
B	0	0	0	0	1	0	1	1	B+ Reference Adjustment
C	0	0	0	0	1	0	0	0	Vertical Moiré
D	0	0	0	0	1	0	0	1	Side Pin Balance
E	0	0	0	0	1	0	1	0	Parallelogram
F	0	0	0	0	1	0	1	1	Vertical Dynamic Focus Amplitude
10	0	0	0	1	0	0	0	0	E/W Corner

Slave Address (8D): Read Mode

No sub address needed.

I²C BUS ADDRESS TABLE

	D8	D7	D6	D5	D4	D3	D2	D1
WRITE MODE								
00		[HDrive 0, off [1], on0]	[0]	Horizontal Duty Cycle				
				[0]	[0]	[0]	[0]	[0]
01	Xray 1, reset [0]	Horizontal Phase Adjustment						
		[1]	[0]	[0]	[0]	[0]	[0]	[0]
02								
03	Sync 0, Comp [1], Sep	Horizontal Focus Amplitude						
				[1]	[0]	[0]	[0]	[0]
04	Detect Refresh [0], off	Horizontal Focus Time Position						
				[1]	[0]	[0]	[0]	[0]
05	Vramp 0, off [1], on	Vertical Ramp Amplitude Adjustment						
		[1]	[0]	[0]	[0]	[0]	[0]	[0]
06	Vertical Position Adjustment							
		[1]	[0]	[0]	[0]	[0]	[0]	[0]
07	S Select 1, on [0]	S Correction						
			[1]	[0]	[0]	[0]	[0]	[0]
08	C Select 1, on [0]	C Correction						
			[1]	[0]	[0]	[0]	[0]	[0]
09	E/W Key 0, off [1]	E/W Keystone						
			[1]	[0]	[0]	[0]	[0]	[0]
0A	E/W Sel 0, off [1]	E/W Amplitude						
		[1]	[0]	[0]	[0]	[0]	[0]	[0]
0B	Test H 1, on [0], off	B + Reference Adjustment						
		[1]	[0]	[0]	[0]	[0]	[0]	[0]
0C	Test V 1, on [0], off	Moiré 1, on [0]	Vertical Moiré					
			[0]	[0]	[0]	[0]	[0]	[0]
0D	SPB Sel 0, off [1]	Side Pin Balance						
			[1]	[0]	[0]	[0]	[0]	[0]
0E	Parallelo 0, off [1]	Parallelogram						
			[1]	[0]	[0]	[0]	[0]	[0]

TDA9109A

	D8	D7	D6	D5	D4	D3	D2	D1
0F	Eq. Pulse 1, on [0], off		Vertical Dynamic Focus Amplitude					
			[1]	[0]	[0]	[0]	[0]	[0]
10	Corner 1, on [0], off		Corner Amplitude Adjustment					
			[1]	[0]	[0]	[0]	[0]	[0]
READ MODE								
	Hlock 0, on [1], no	Vlock 0, on [1], no	Xray 1, on [0], off	Polarity Detection		Sync Detection		
				H/V pol [1], negative	V pol [1], negative	Vext det [0], no det	H/V det [0], no det	V det [0], no det

[x] Initial value

Data is transferred with vertical sawtooth retrace.

We recommend setting the unspecified bit to [0] in order to ensure compatibility with future devices.

OPERATING DESCRIPTION

1 GENERAL CONSIDERATIONS

1.1 Power Supply

The typical values of the power supply voltages V_{CC} and V_{DD} are 12 V and 5 V respectively. Optimum operation is obtained for V_{CC} between 10.8 and 13.2 V and V_{DD} between 4.5 and 5.5 V.

In order to avoid erratic operation of the circuit during the transient phase of V_{CC} switching on, or off, the value of V_{CC} is monitored: if V_{CC} is less than 7.5 V typ., the outputs of the circuit are inhibited.

Similarly, before V_{DD} reaches 4 V, all the I²C register are reset to their default value (see I²C Control Table).

In order to have very good power supply rejection, the circuit is internally supplied by several voltage references (typ. value: 8.2 V). Two of these voltage references are externally accessible, one for the vertical and one for the horizontal part. They can be used to bias external circuitry (if I_{LOAD} is less than 5 mA). It is necessary to filter the voltage references by external capacitors connected to ground, in order to minimize the noise and consequently the "jitter" on vertical and horizontal output signals.

1.2 I²C Control

TDA9109A belongs to the I²C controlled device family. Instead of being controlled by DC voltages on dedicated control pins, each adjustment can be done via the I²C Interface.

The I²C bus is a serial bus with a clock and a data input. The general function and the bus protocol are specified in the Philips-bus data sheets.

The interface (Data and Clock) is a comparator whose threshold is 2.2 V with a 5 V supply. Spikes of up to 50 ns are filtered by an integrator and the maximum clock speed is limited to 400 kHz.

The data line (SDA) can be used bidirectionally. In read-mode the IC sends reply information (1 byte) to the micro-processor.

The bus protocol prescribes a full-byte transmission in all cases. The first byte after the start condition is used to transmit the IC-address (hexa 8C for write, 8D for read).

1.3 Write Mode

In write mode the second byte sent contains the subaddress of the selected function to adjust (or controls to affect) and the third byte the corresponding data byte. It is possible to send more than one data byte to the IC. If after the third byte no stop or start condition is detected, the circuit increments automatically by one the momentary subaddress in the subaddress counter (auto-increment mode). So it is possible to transmit immediately the following data bytes without sending the IC address or subaddress. This can be useful to reinitialize all the controls very quickly (flash manner). This procedure can be finished by a stop condition.

The circuit has 18 adjustment capabilities: 3 for the horizontal part, 4 for the vertical, 3 for the E/W correction, 2 for the dynamic horizontal phase control, 2 for the vertical and horizontal Moiré options, 3 for the horizontal and the vertical dynamic focus and 1 for the B+ reference adjustment.

18 bits are also dedicated to several controls (ON/OFF, Horizontal Forced Frequency, Sync Priority, Detection Refresh and XRAY reset).

1.4 Read Mode

During the read mode the second byte transmits the reply information.

The reply byte contains the horizontal and vertical lock/unlock status, the XRAY activation status and, the horizontal and vertical polarity detection. It also contains the sync detection status which is used by the MCU to assign the sync priority. A stop condition always stops all the activities of the bus decoder and switches to high impedance both the data and clock line (SDA and SCL).

See I²C subaddress and control tables.

1.5 Sync Processor

The internal sync processor allows the TDA9109A to accept:

- separated horizontal & vertical TTL-compatible sync signal
- composite horizontal & vertical TTL-compatible sync signal

1.6 Sync Identification Status

The MCU can read (address read mode: 8D) the status register via the I²C bus, and then select the sync priority depending on this status.

Among other data this register indicates the presence of sync pulses on H/HVIN, VSYNCIN and (when 12 V is supplied) whether a Vext has been extracted from H/HVIN. Both horizontal and vertical sync are detected even if only 5 V is supplied.

In order to choose the right sync priority the MCU may proceed as follows (see I²C Address Table):

- refresh the status register
- wait at least for 20ms (Max. vertical period)
- read this status register

Sync priority choice should be:

Vextdet	HVdet	Vdet	Sync priority Subaddress 03 (D8)	Comment Sync type
No	Yes	Yes	1	Separated H&V
Yes	Yes	No	0	Composite TTL H&V

2 HORIZONTAL PART

2.1 Internal Input Conditions

A digital signal (horizontal sync pulse or TTL composite) is sent by the sync processor to the horizontal input. It may be positive or negative (see Figure 5).

Of course, when the choice is made, we can refresh the sync detections and verify that the extracted Vsync is present and that no sync type change has occurred. The sync processor also gives sync polarity information.

1.7 IC status

The IC can inform the MCU about the 1st horizontal PLL and vertical section status (locked or not) and about the XRAY protection (activated or not). Resetting the XRAY internal latch can be done either by decreasing the V_{CC} supply or directly resetting it via the I²C interface.

1.8 Sync Inputs

Both H/HVIN and VSYNCIN inputs are TTL compatible triggers with hysteresis to avoid erratic detection. Both inputs include a pull up resistor connected to V_{DD}.

1.9 Sync Processor Output

The sync processor indicates on the D8 bit of the status register whether 1st PLL is locked to an incoming horizontal sync. Its level goes to low when locked. This information is also available on pin 3 when sub-address 02 D8 is equal to 1. When PLL1 is unlocked, pin 3 output voltage goes to 5V.

Using internal integration, both signals are recognized if Z/T < 25%. Synchronization occurs on the leading edge of the internal sync signal.

The minimum value of Z is 0.7 μs.

Another integration is able to extract the vertical pulse from composite sync if the duty cycle is higher than 25% (typically d = 35%), (see Figure 6).

Figure 5.

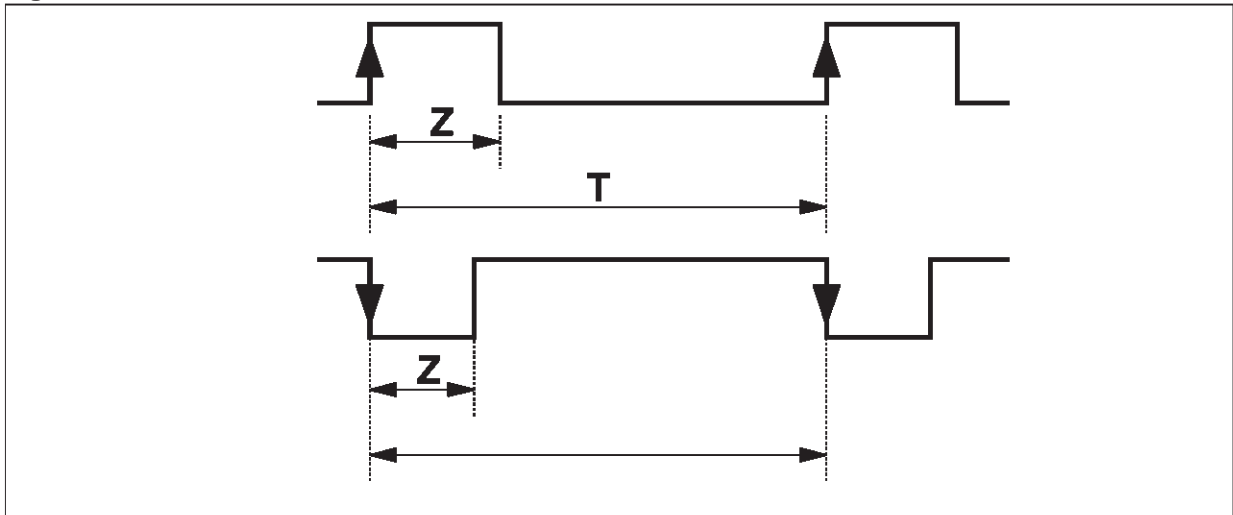
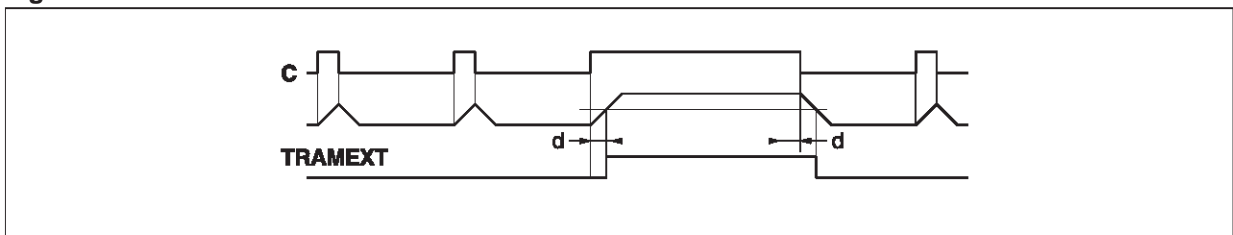

Figure 6.



The last feature performed is the removal of equalization pulses to avoid parasitic pulses on the phase comparator (which would be disturbed by missing or extraneous pulses). This last feature is switched on/off by sub-address 0F D8. By default [0], equalization pulses will not be removed.

2.2 PLL1

The PLL1 consists of a phase comparator, an external filter and a voltage-controlled oscillator (VCO). The phase comparator is a “phase frequency” type designed in CMOS technology. This kind

of phase detector avoids locking on wrong frequencies. It is followed by a “charge pump”, composed of two current sources : sunk and sourced (typically $I = 1 \text{ mA}$ when locked and $I = 140 \mu\text{A}$ when unlocked). This difference between lock/unlock allows smooth catching of the horizontal frequency by PLL1. This effect is reinforced by an internal original slow down system when PLL1 is locked, avoiding the horizontal frequency changing too quickly. The dynamic behavior of PLL1 is fixed by an external filter which integrates the current of the charge pump. A “CRC” filter is generally used (see Figure 7)

Figure 7.

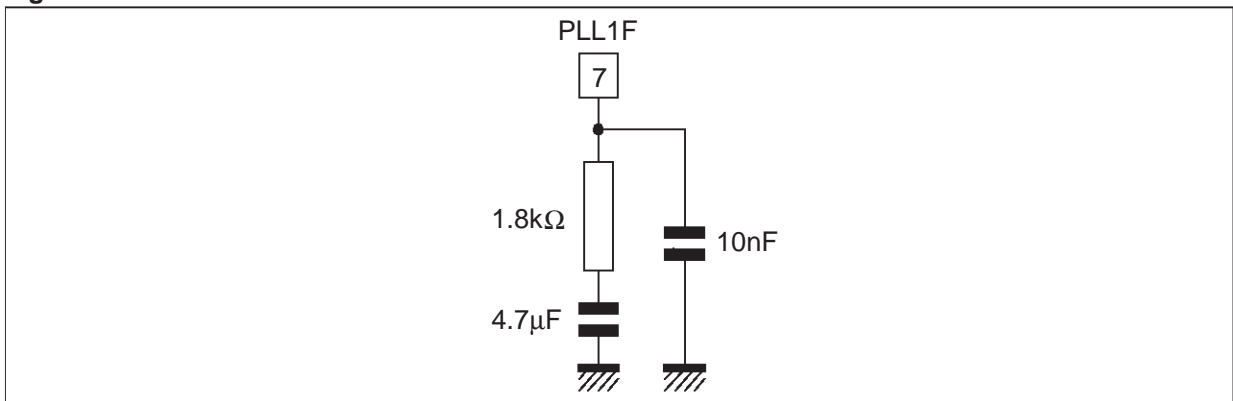

The PLL1 is internally inhibited during extracted vertical sync (if any) to avoid taking in account missing pulses or wrong pulses on phase

comparator. Inhibition is obtained by stopping high and low signals at the entry of the charge pump block (see Figure 8).

Figure 8.

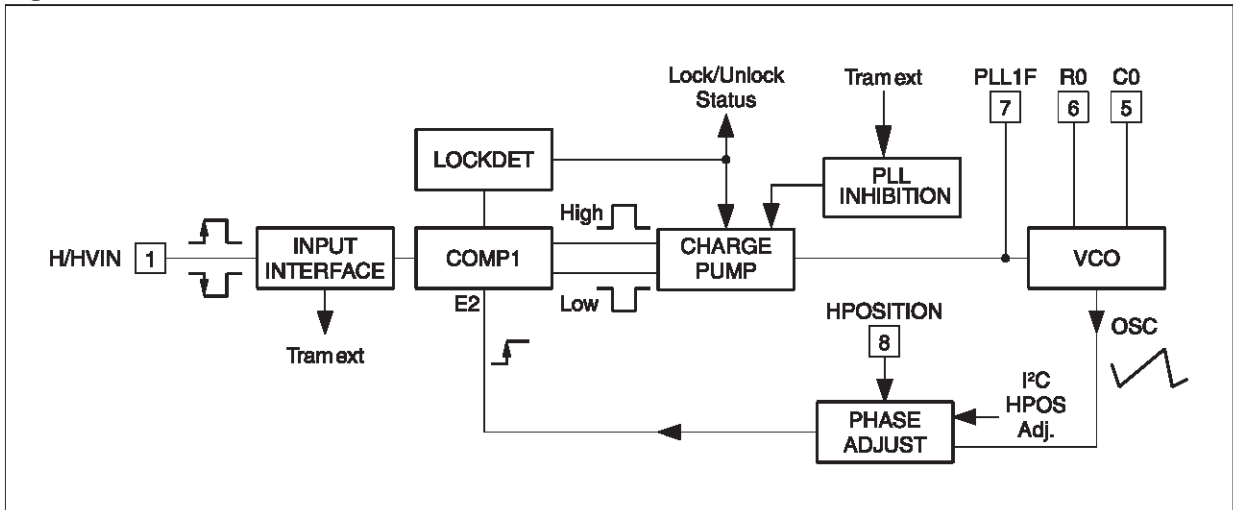
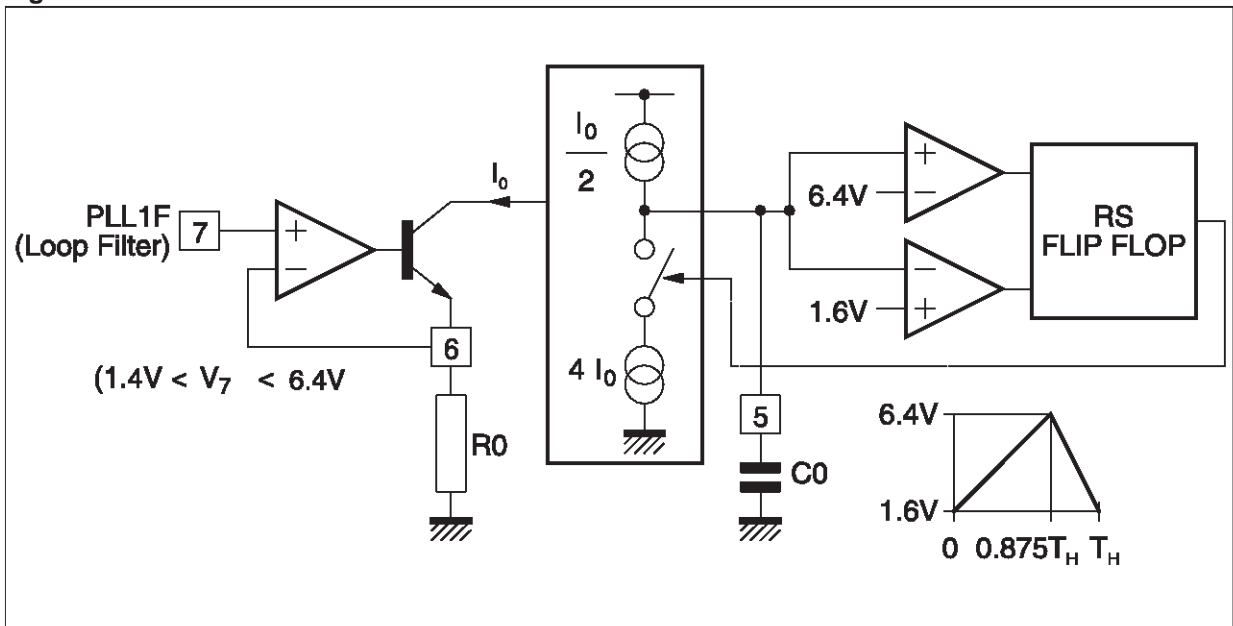

Figure 9.



The VCO uses an external RC network. It delivers a linear sawtooth obtained by the charge and the discharge of the capacitor, with a current proportional to the current in the resistor. The typical thresholds of the sawtooth are 1.6 V and 6.4 V.

The control voltage of the VCO is between 1.4 V and 6.4 V (see Figure 9). The theoretical frequency range of this VCO is in the ratio of 1 to 4.5. The effective frequency range has to be smaller (1 to 4.2) due to clamp intervention on the filter lowest value.

The sync frequency must always be higher than the free running frequency. For example, when using a sync range between 24.8 kHz and 100 kHz, the suggested free running frequency is 23 kHz.

PLL1 ensures the coincidence between the leading edge of the sync signal and a phase reference obtained by comparison between the sawtooth of the VCO and an internal DC voltage which is I²C adjustable between 2.9 V and 4.2 V (corresponding to ±10 %) (see Figure 10).

The TDA9109A also includes a Lock/Unlock identification block which senses in real time whether PLL1 is locked or not on the incoming horizontal sync signal.

The lock/unlock information is available through the I²C read and the pin 3 voltage level

PLL1 Timing Diagram

Figure 10.

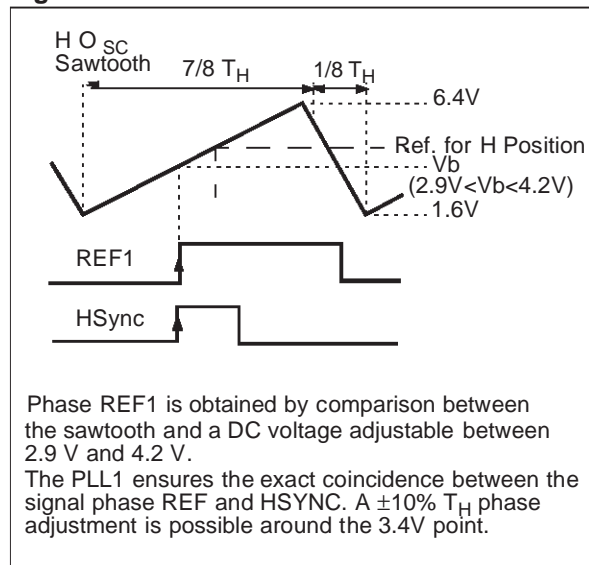

2.3 PLL2

PLL2 ensures a constant position of the shaped flyback signal in comparison with the sawtooth of the VCO, taking into account the saturation time T_s (see Figure 11)

Figure 11. PLL2 Timing Diagram

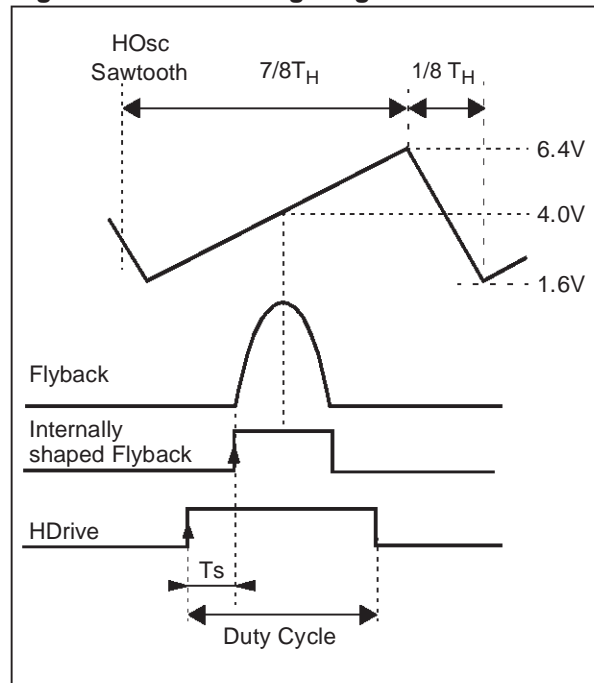

The phase comparator of PLL2 (phase type comparator) is followed by a charge pump (typical output current: 0.5 mA).

The flyback input consists of an NPN transistor.

This input must be current driven. The maximum recommended input current is 5 mA (see Figure 12).

Figure 12. Flyback Input Electrical Diagram

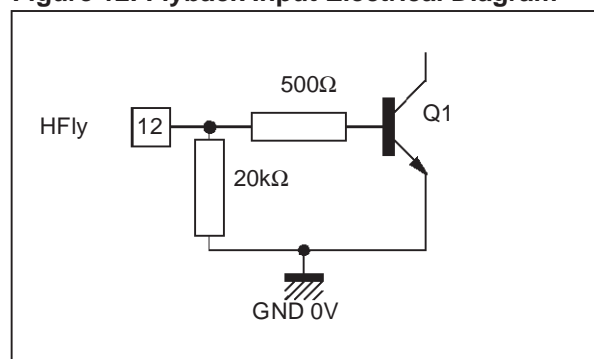

The duty cycle is adjustable through I²C from 30 % to 65 %. For a safe start-up operation, the initial duty cycle (after power-on reset) is 65% in order to avoid having too long a conduction period of the horizontal scanning transistor.

The maximum storage time (T_s Max.) is $(0.44T_H - T_{FLY}/2)$. Typically, T_{FLY}/T_H is around 20 % which means that T_s max is around 34 % of T_H .

2.4 Output Section

The H-drive signal is sent to the output through a shaping stage which also controls the H-drive duty cycle (I²C adjustable) (see Figure 11). In order to secure the scanning power part operation, the output is inhibited in the following cases:

- when V_{CC} or V_{DD} are too low
- when the XRAY protection is activated
- during the Horizontal flyback
- when the HDrive I²C bit control is off

The output stage consists of a NPN bipolar transistor. Only the collector is accessible (see Figure 13).

Figure 13.

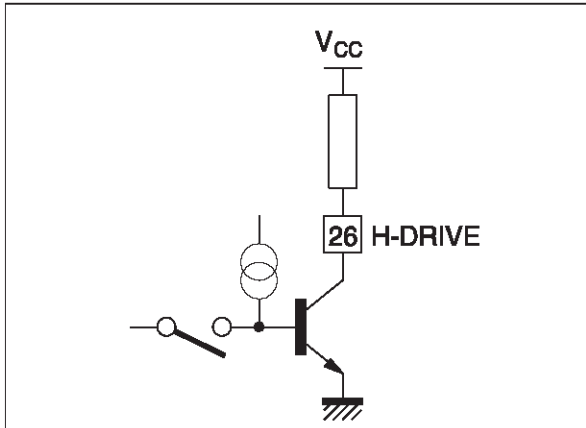
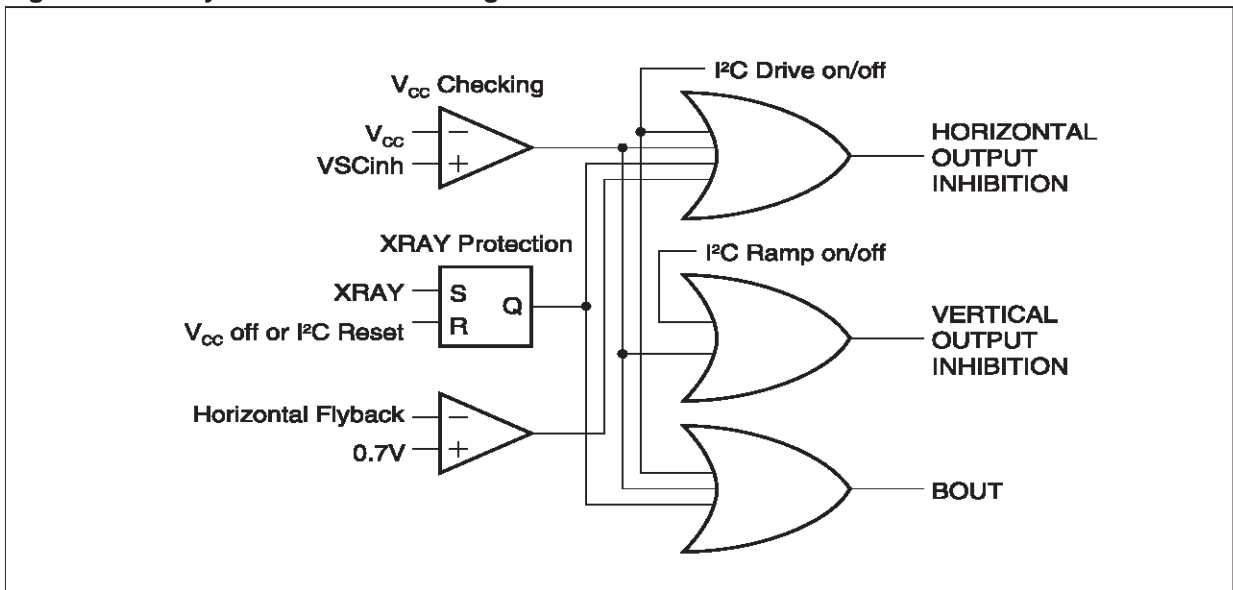

Figure 14. Safety Functions Block Diagram



This output stage is intended for “reverse” base control, where setting the output NPN in off-state will control the power scanning transistor in off-state.

The maximum output current is 30mA, and the corresponding voltage drop of the output V_{CEsat} is 0.4V Max.

Obviously the power scanning transistor cannot be directly driven by the integrated circuit. An interface has to be added between the circuit and the power transistor either of bipolar or MOS type.

2.5 X-RAY Protection

The X-Ray protection is activated by application of a high level on the X-Ray input (8.2V on Pin 25). It inhibits the H-Drive and B+ outputs.

This activation is internally delayed by 2 lines to avoid erratic detection (short parasitics).

This protection is latched; it may be reset either by V_{CC} switch off or by I²C (see Figure 14).

2.6 Horizontal and Vertical Dynamic Focus

The TDA9109A delivers a horizontal parabola which is added on a vertical parabola waveform on Pin 10. This horizontal parabola comes from a sawtooth in phase advance with flyback pulse middle. The time advance versus horizontal flyback

middle is kept constant versus frequency (about $1\mu\text{s}$).

Symmetry and amplitude are I^2C adjustable (see Figure 15). The vertical dynamic focus is tracked with VPOS and VAMP. Its amplitude can be adjusted. It is also affected by S and C corrections. This positive signal once amplified is to be sent to the CRT focusing grids.

Figure 15. Phase of HFocus Parabola

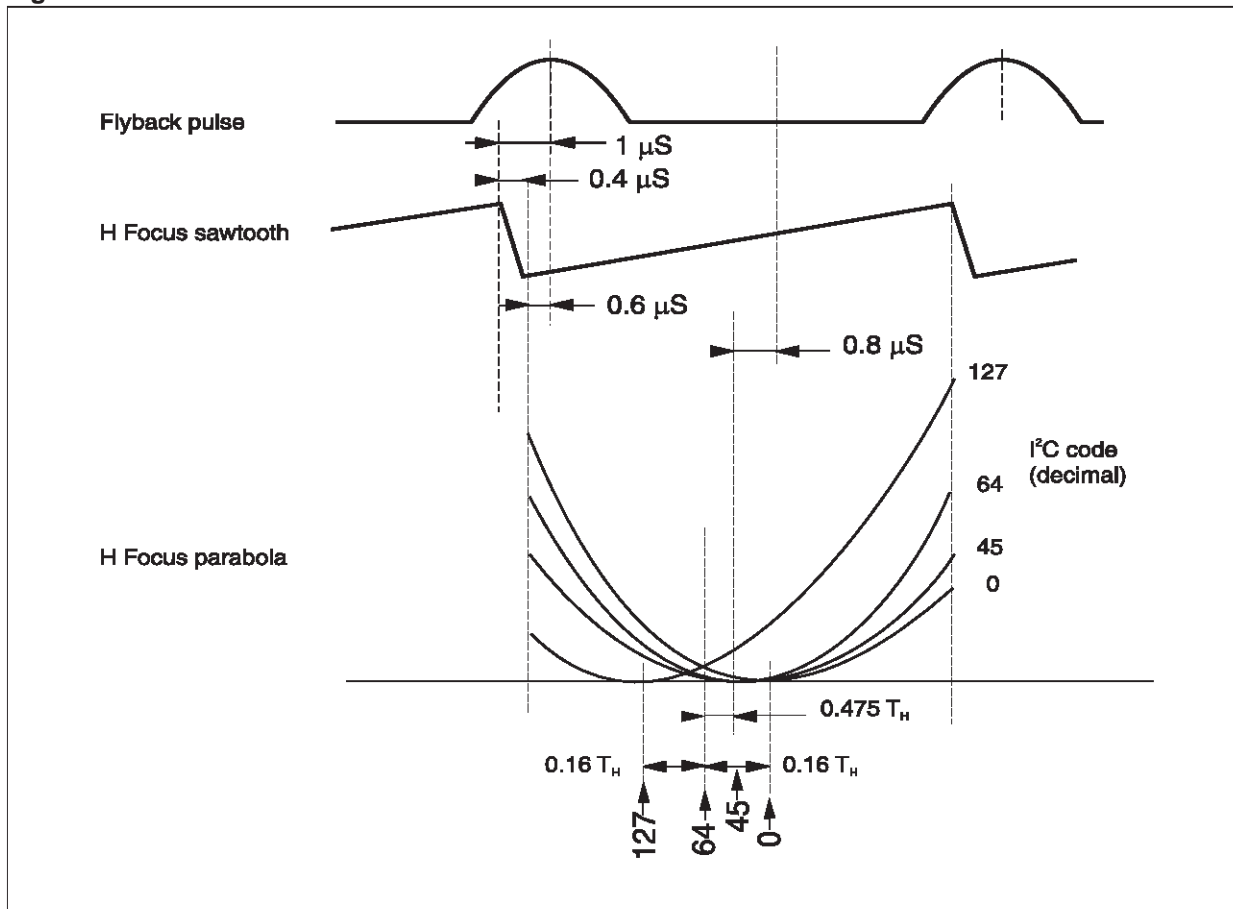

3 VERTICAL PART

3.1 Function

When the synchronization pulse is not present, an internal current source sets the free running frequency. For an external capacitor, $C_{OSC} = 150\text{nF}$, the typical free running frequency is 100Hz.

The typical free running frequency can be calculated by:

$$f_0(\text{Hz}) = 1.5 \cdot 10^{-5} \cdot \frac{1}{C_{OSC}}$$

A negative or positive TTL level pulse applied on Pin 2 (VSYNC) as well as a TTL composite sync on Pin 1 can synchronize the ramp in the range [fmin, fmax] (See Figure 16). This frequency range depends on the external capacitor connected on Pin 22. A 150nF ($\pm 5\%$) capacitor is recommended for 50Hz to 185Hz applications.

If a synchronization pulse is applied, the internal oscillator is synchronized immediately but with wrong amplitude. An internal correction then adjusts it in less than half a second. The top value of the ramp (Pin 22) is sampled on the AGC capacitor (Pin 20) at each clock pulse and a transconductance amplifier modifies the charge current of the capacitor in such a way to make the amplitude constant again.

The read status register provides the vertical Lock-Unlock and the vertical sync polarity information.

We recommend the use of an AGC capacitor with low leakage current. A value lower than 100nA is mandatory.

A good stability of the internal closed loop is reached by a $470\text{nF} \pm 5\%$ capacitor value on Pin 20 (VAGC).

3.2 I²C Control Adjustments

S and C correction shapes can then be added to this ramp. These frequency-independent S and C corrections are generated internally. Their amplitudes are adjustable by their respective I²C registers. They can also be inhibited by their "select" bits.

Finally, the amplitude of this S and C corrected ramp can be adjusted by the vertical ramp amplitude control register.

The adjusted ramp is available on Pin 23 (V_{OUT}) to drive an external power stage.

The gain of this stage can be adjusted ($\pm 25\%$) depending on its register value.

The mean value of this ramp is driven by its own I²C register (vertical position). Its value is $V_{POS} = 7/16 \cdot V_{REF-V} \pm 400\text{mV}$.

Usually V_{OUT} is sent through a resistive divider to the inverting input of the booster. Since V_{POS} derives from V_{REF-V}, the bias voltage sent to the non-inverting input of the booster should also derive from V_{REF-V} to optimize the accuracy (see Application Diagram).

3.3 Vertical Moiré

By using the vertical moiré, V_{POS} can be modulated from frame to frame. This function is intended to cancel the fringes which appear when the line to line interval is very close to the CRT vertical pitch.

The amplitude of the modulation is controlled by register VMOIRE on sub-address 0C and can be switched-off via the control bit D8.

Figure 16. AGC Loop Block Diagram

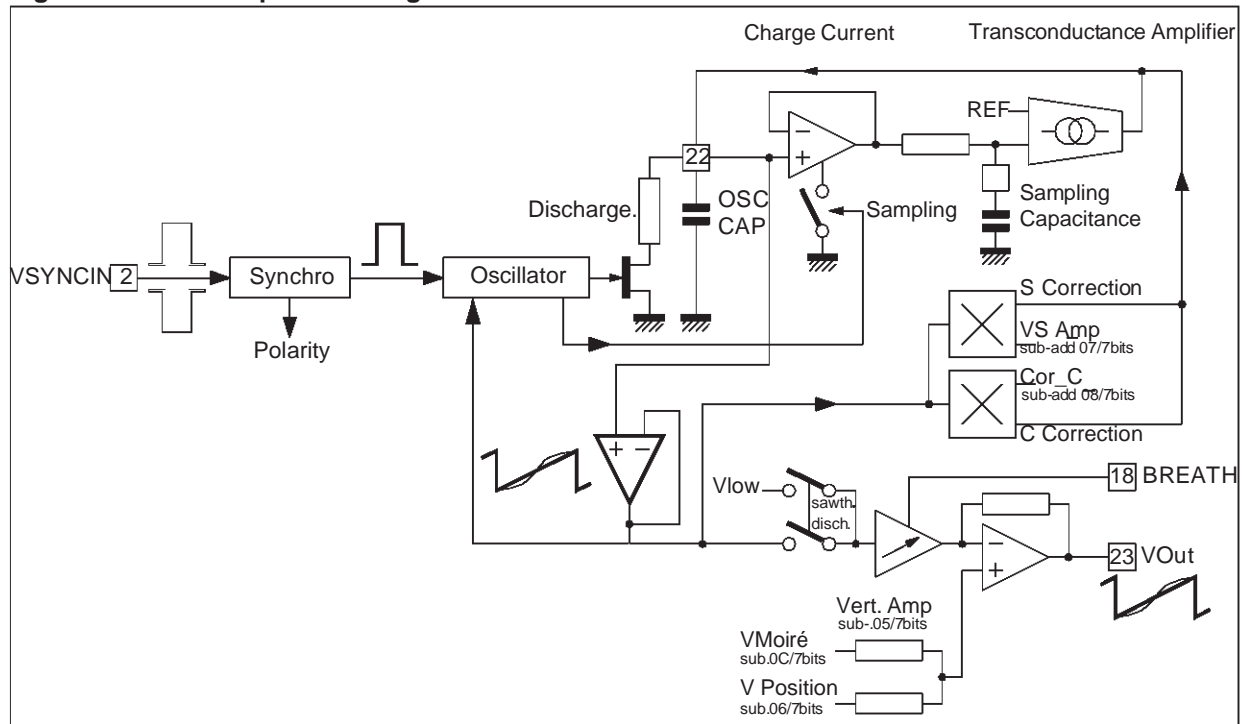

3.4 Basic Equations

In first approximation, the amplitude of the ramp on Pin 23 (VOUT) is:

$$V_{OUT} - V_{POS} = (V_{OSC} - V_{DCMID}) \cdot (1 + 0.3 (V_{AMP}))$$

where:

$$V_{DCMID} = 7/16 V_{REF} \text{ (middle value of the ramp on Pin 22, typically 3.6V)}$$

$$V_{OSC} = V_{22} \text{ (ramp with fixed amplitude)}$$

$$V_{AMP} = -1 \text{ for minimum vertical amplitude register value and } +1 \text{ for maximum}$$

VPOS is calculated by:

$$V_{POS} = V_{DCMID} + 0.4 V_P$$

where $V_P = -1$ for minimum vertical position register value and $+1$ for maximum.

The current available on Pin 22 is:

$$I_{OSC} = \frac{3}{8} \cdot V_{REF} \cdot C_{OSC} \cdot f$$

where C_{OSC} = capacitor connected on Pin 22 and f = synchronization frequency.

Geometric Corrections

The principle is represented in Figure 17.

Starting from the vertical ramp, a parabola-shaped current is generated for E/W correction (also known as Pin Cushion correction), dynamic horizontal phase control correction, and vertical dynamic focus correction.

The parabola generator is made by an analog multiplier, the output current of which is equal to:

$$\Delta I = k \cdot (V_{OUT} - V_{DCMID})^2$$

where V_{OUT} is the vertical output ramp (typically between 2 and 5V) and V_{DCMID} is 3.6V (for $V_{REF-V} = 8.2V$). The VOUT sawtooth is typically centered on 3.6V. By changing the vertical position, the sawtooth shifts by $\pm 0.4V$.

To provide good screen geometry for any end user adjustment, the TDA9109A has the "geometry tracking" feature which allows generation of a dissymmetric parabola depending on the vertical position.

Due to the large output stage voltage range (E/W Pin Cushion, Keystone, E/W Corner), the combination of the tracking function, maximum vertical amplitude, maximum or minimum vertical position and maximum gain on the DAC control may lead to output stage saturation. This must be avoided by limiting the output voltage with appropriate I^2C register values.

For the E/W part and the dynamic horizontal phase control part, a sawtooth-shaped differential current in the following form is generated:

$$\Delta I' = k' \cdot (V_{OUT} - V_{DCMID})$$

Then ΔI and $\Delta I'$ are added and converted into voltage for the E/W part.

Each of the two E/W components or the two dynamic horizontal phase control components may be inhibited by their own I²C select bit.

The E/W parabola is available on Pin 24 via an emitter follower output stage which has to be biased by an external resistor (10kΩ to ground). Since stable in temperature, the device can be DC coupled with external circuitry.

The vertical dynamic focus is combined with the horizontal focus on Pin 10.

The dynamic horizontal phase control drives internally the H-position, moving the HFLY position on the horizontal sawtooth in the range of ± 2.8 %T_H both for side pin balance and parallelogram.

Figure 17. Geometric Corrections Principle

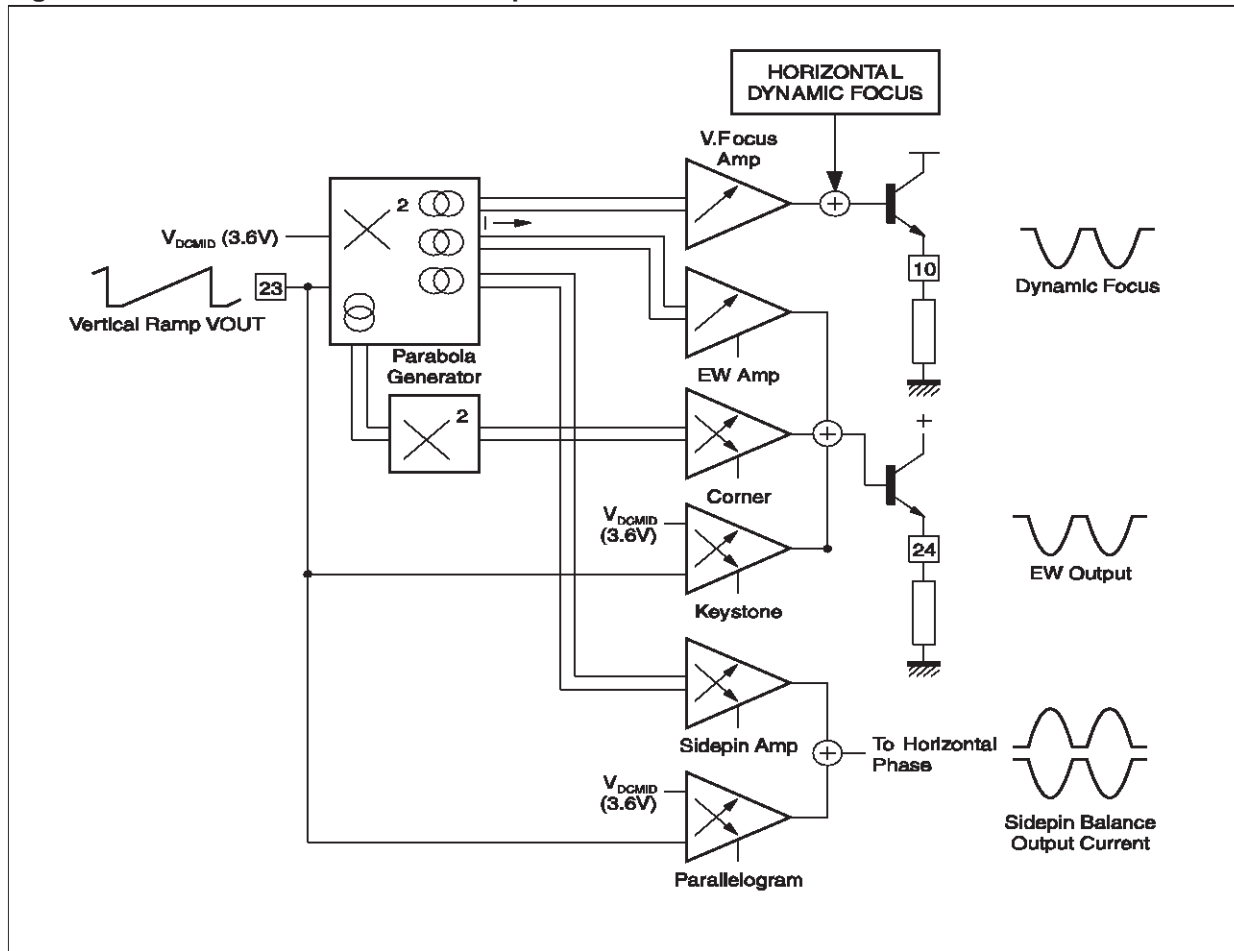

3.5 E/W

$EW_{OUT} = EW_{DC} + K1 (V_{OUT} - V_{DCMID}) + K2 (V_{OUT} - V_{DCMID})^2 + K3 (V_{OUT} - V_{DCMID})^4$
 K1 is adjustable by the keystone I²C register.
 K2 is adjustable by the E/W amplitude I²C register.
 K3 is adjustable by the E/W corner I²C register.

3.6 Dynamic Horizontal Phase Control

$I_{OUT} = K4 (V_{OUT} - V_{DCMID}) + K5 (V_{OUT} - V_{DCMID})^2$
 K4 is adjustable by the parallelogram I²C register.
 K5 is adjustable by the side pin balance I²C register.

4 DC/DC CONVERTER PART

This unit controls the switch-mode DC/DC converter. It converts a DC constant voltage into the B+ voltage (roughly proportional to the horizontal frequency) necessary for the horizontal scanning.

This DC/DC converter can be configured either in step-up or step-down mode. In both cases it operates very similarly to the well known UC3842.

4.1 Step-up Mode

Operating Description

- The power MOS is switched-on during the flyback (at the beginning of the positive slope of the horizontal focus sawtooth).
- The power MOS is switched-off when its current reaches a predetermined value. For this purpose, a sense resistor is inserted in its source. The voltage on this resistor is sent to Pin16 (I_{SENSE}).
- The feedback (coming either from the EHV or from the flyback) is divided to a voltage close to 5.0V and compared to the internal 5.0V reference (V_{REF}). The difference is amplified by an error amplifier, the output of which controls the power MOS switch-off current.

Main Features

- Switching synchronized on the horizontal frequency
- B+ voltage always higher than the DC source
- Current limited on a pulse-by-pulse basis

The DC/DC converter is disabled:

- when V_{CC} or V_{DD} are too low
- when X-Ray protection is latched
- directly through I²C bus

When disabled, BOUT is driven to GND by a 0.5mA current source. This feature allows to implement externally a soft start circuit.

4.2 Step-down Mode

In step-down mode, the I_{SENSE} information is not used any more and therefore not sent to the Pin16. This mode is selected by connecting Pin16 to a DC voltage higher than 6V (for example V_{REF}).

Operating Description

- The power MOS is switched-on as for the step-up mode
- The feedback to the error amplifier is done as for the step-up mode
- The power MOS is switched-off when the HFOCUSCAP voltage get higher than the error amplifier output voltage

Main Features

- Switching synchronized on the horizontal frequency
- B+ voltage always lower than the DC source
- No current limitation

4.3 Step-up and Step-down Mode Comparison

In step-down mode the control signal is inverted compared with the step-up mode.

The reason for this, is the following:

- In step-up mode, the switch is a N-channel MOS referenced to ground and made conductive by a high level on its gate.
- In step-down, a high-side switch is necessary. It can be either a P- or a N-channel MOS.
 - For a P-channel MOS, the gate is controlled directly from Pin 28 through a capacitor (this allows to spare a Transformer). In this case, a negative-going pulse is needed to make the MOS conductive. Therefore it is necessary to invert the control signal.
 - For a N-channel MOS, a transformer is needed to control the gate. The polarity of the transformer can be easily adapted to the negative-going control pulse.

Figure 18. DC/DC Converter

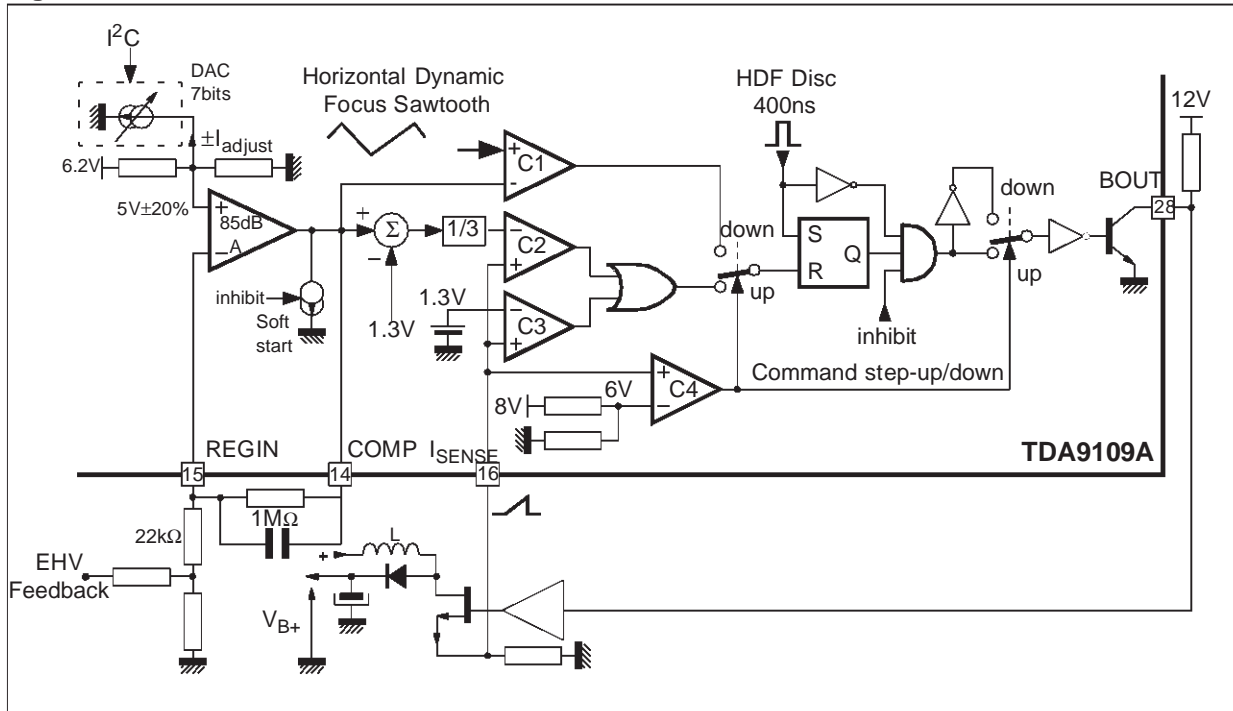

INTERNAL SCHEMATICS

Figure 19.

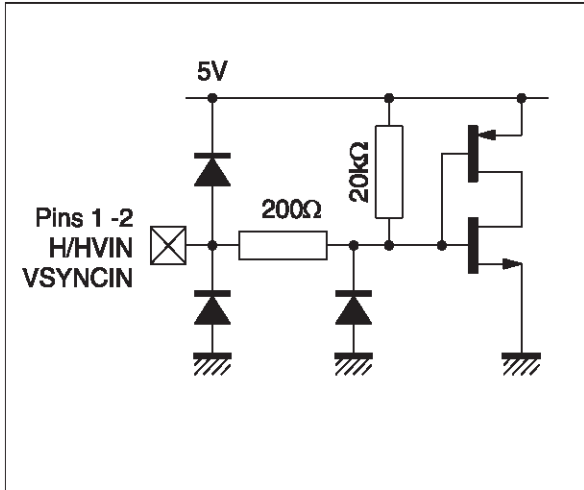

Figure 22.

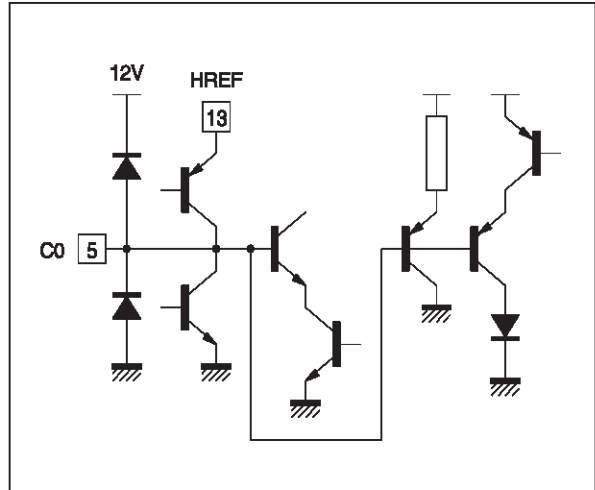

Figure 20.

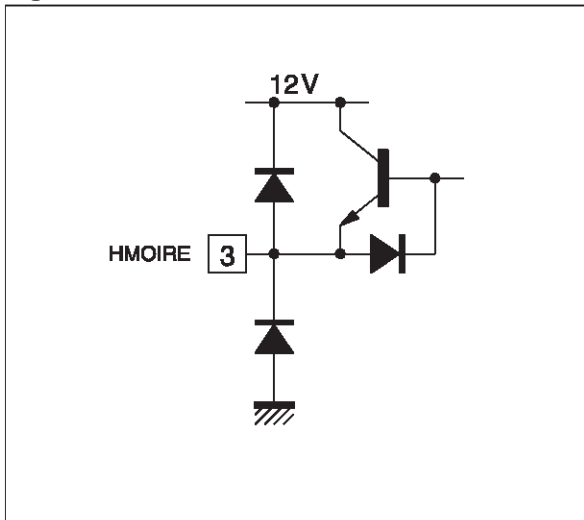

Figure 23.

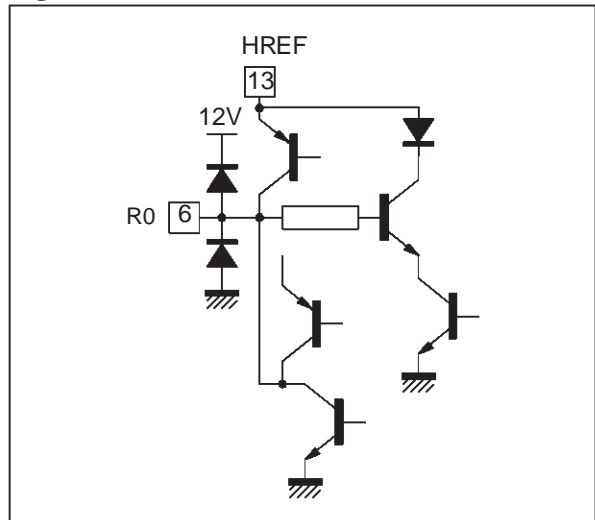

Figure 21.

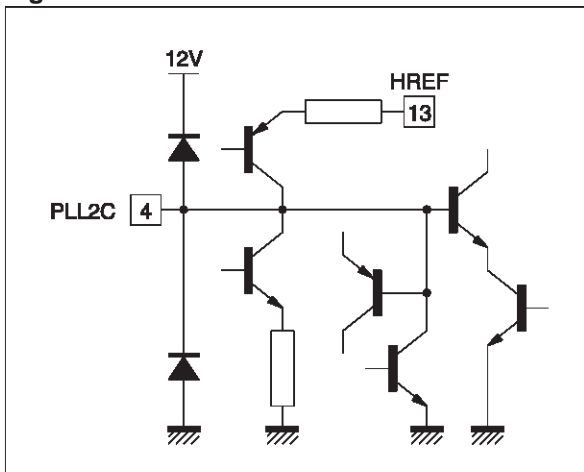

Figure 24.

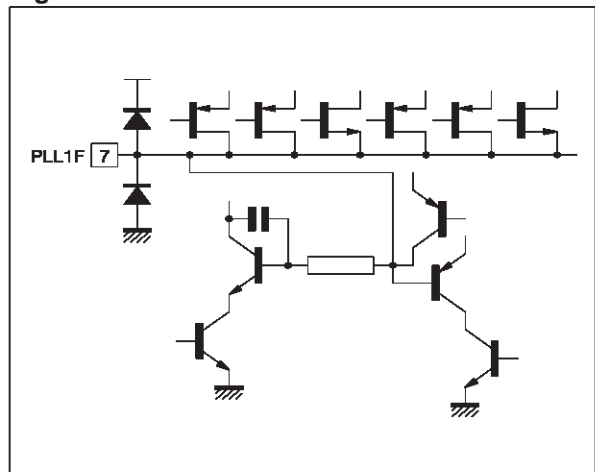

Figure 25.

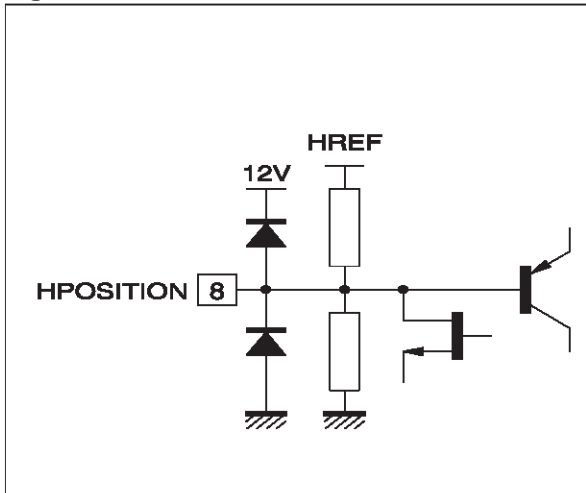

Figure 28.

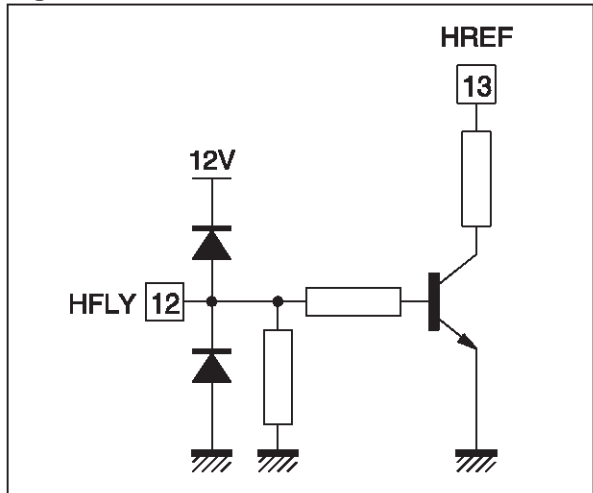

Figure 26.

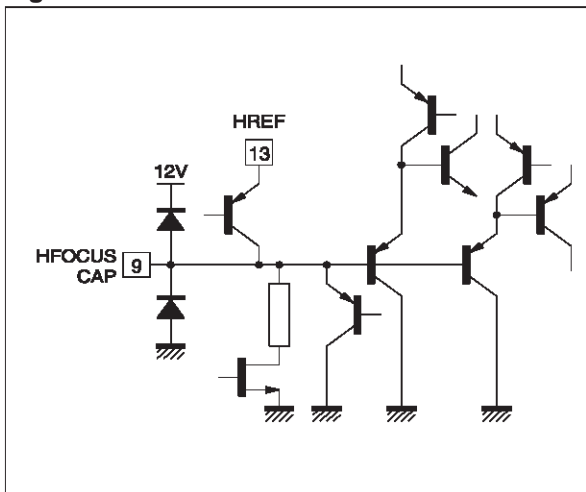

Figure 29.

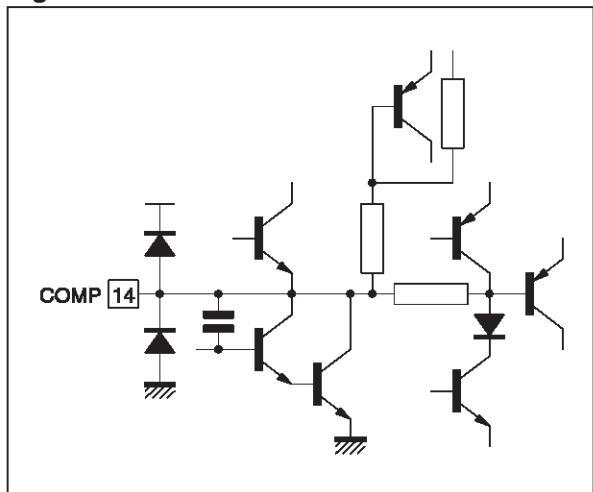

Figure 27.

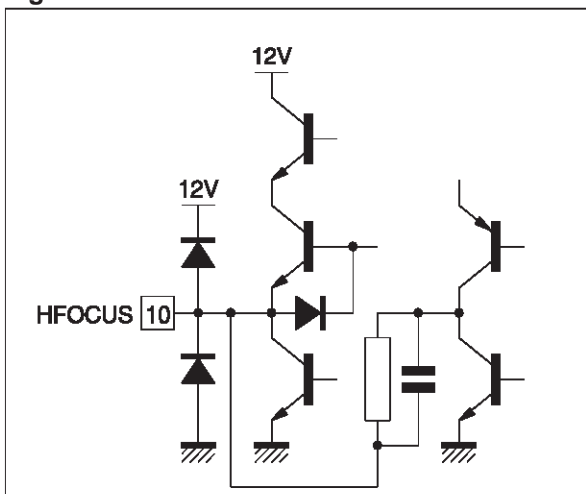

Figure 30.

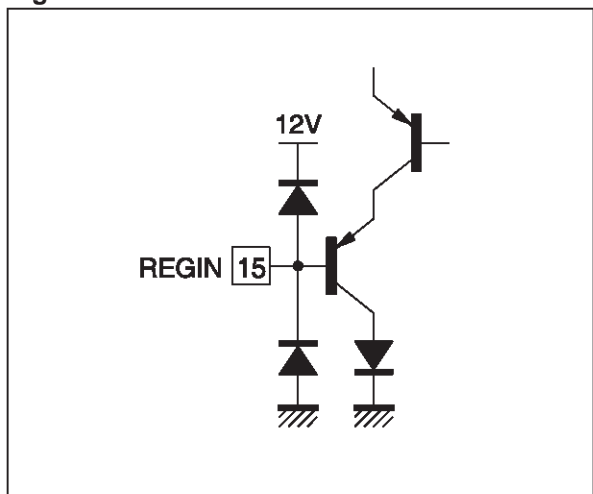

Figure 31.

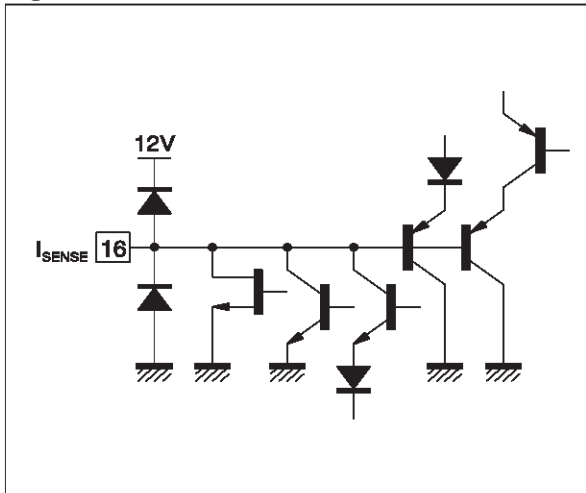

Figure 32.

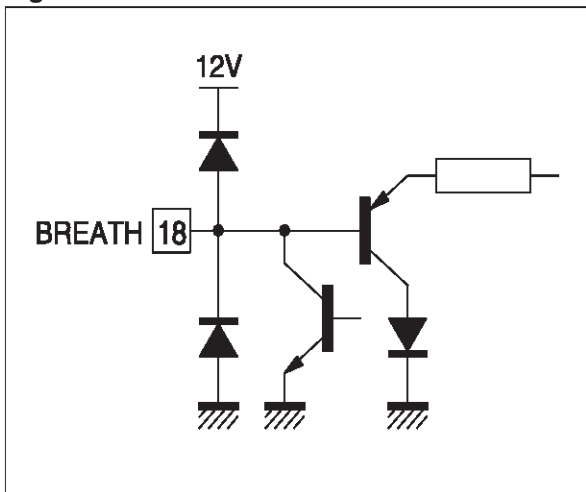

Figure 33.

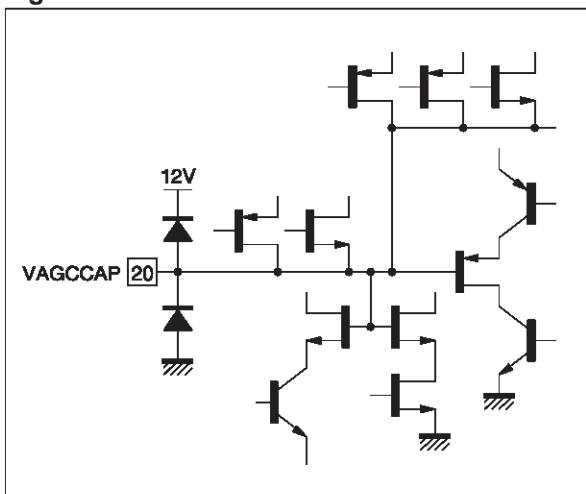

Figure 34.

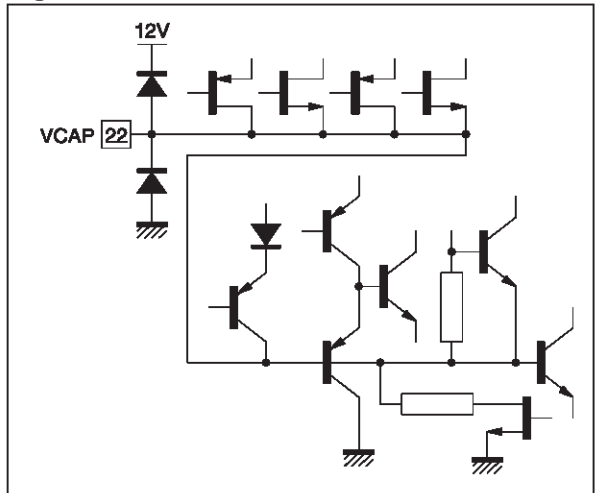

Figure 35.

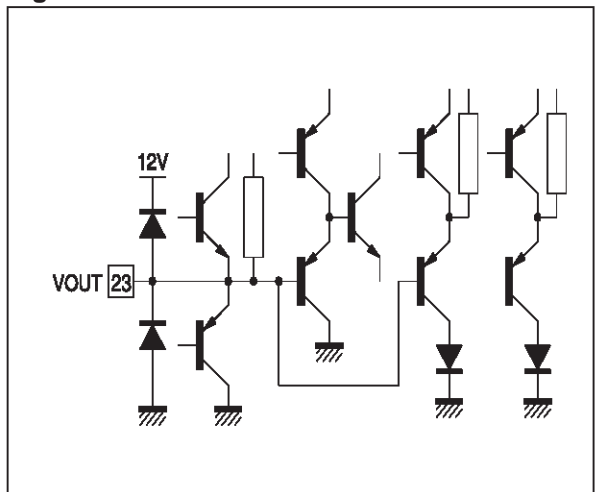

Figure 36.

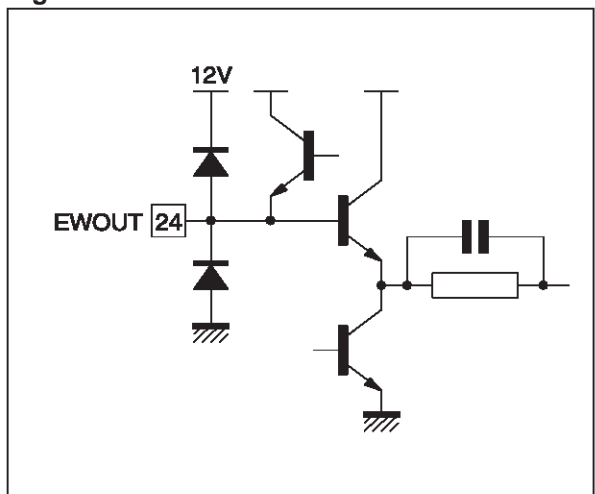

Figure 37.

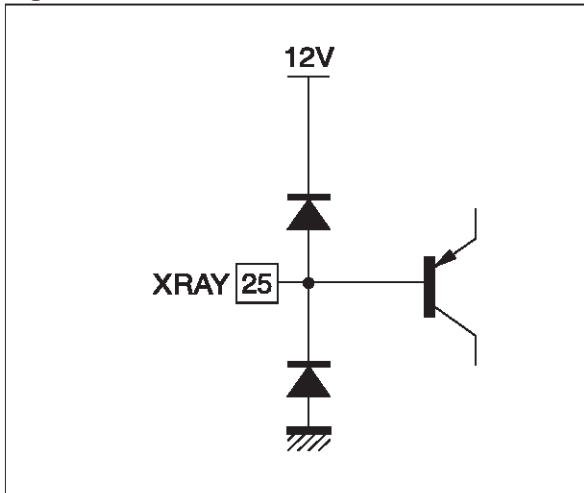

Figure 38.

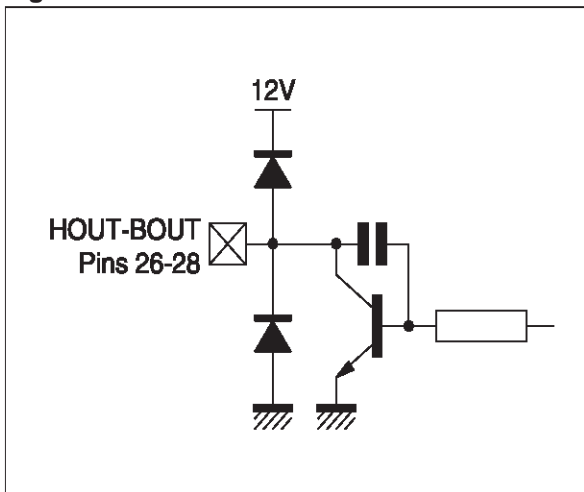

Figure 39.

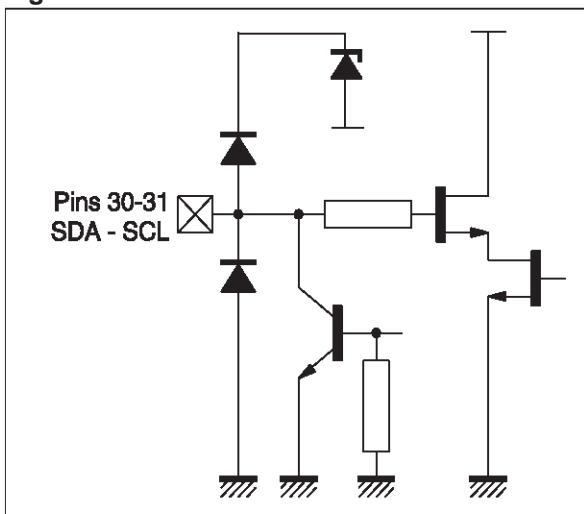

Figure 40. Demonstration Board

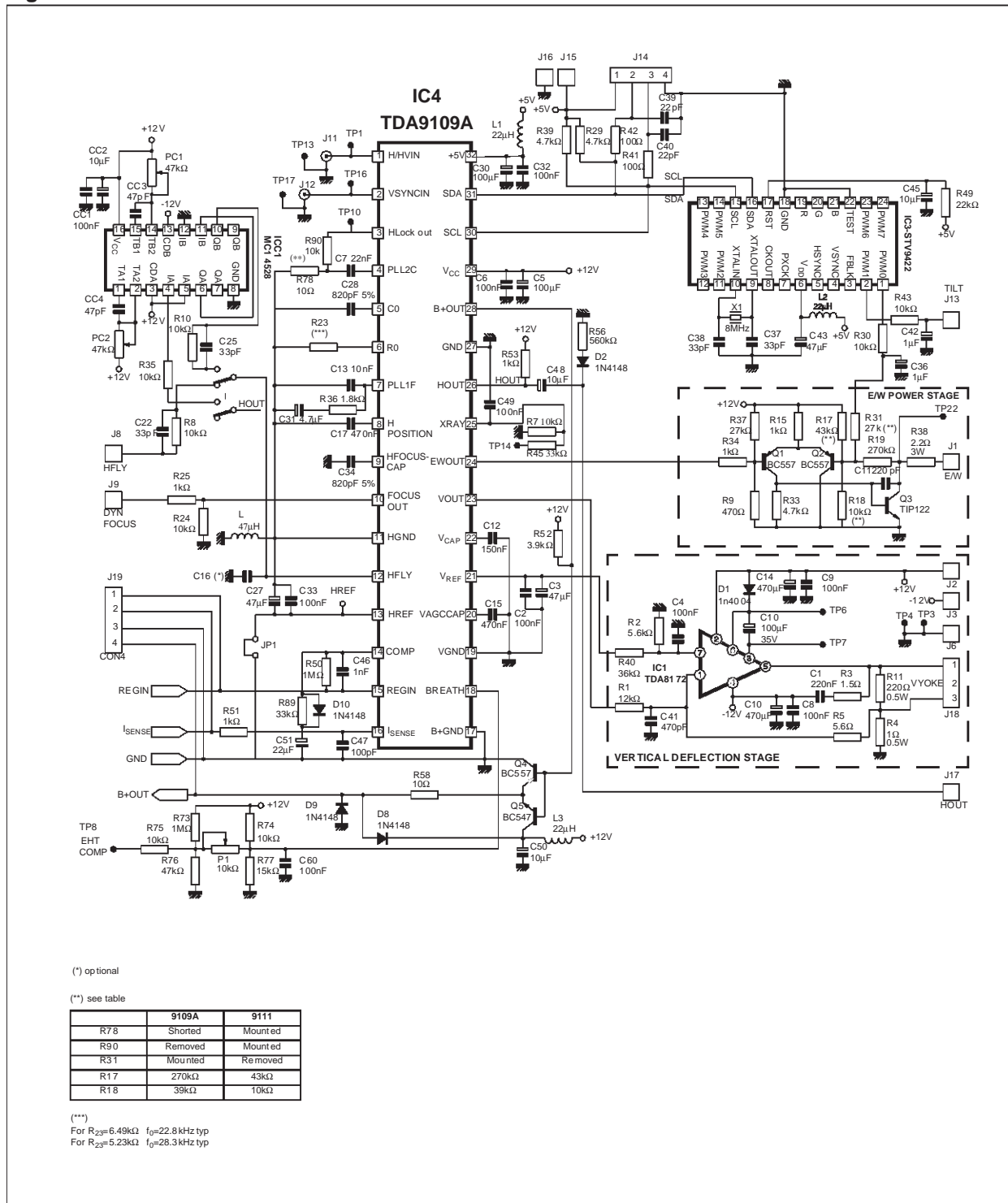
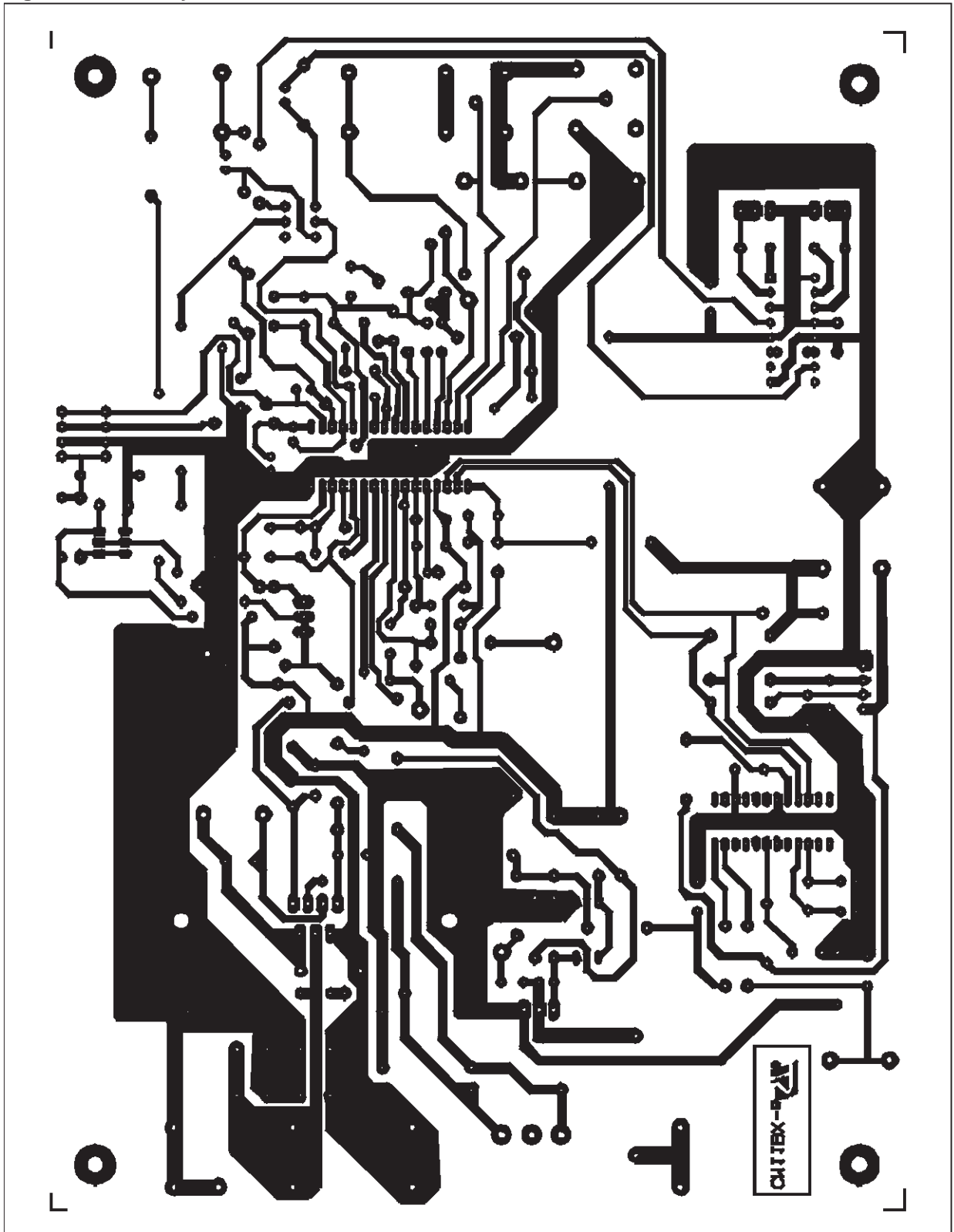
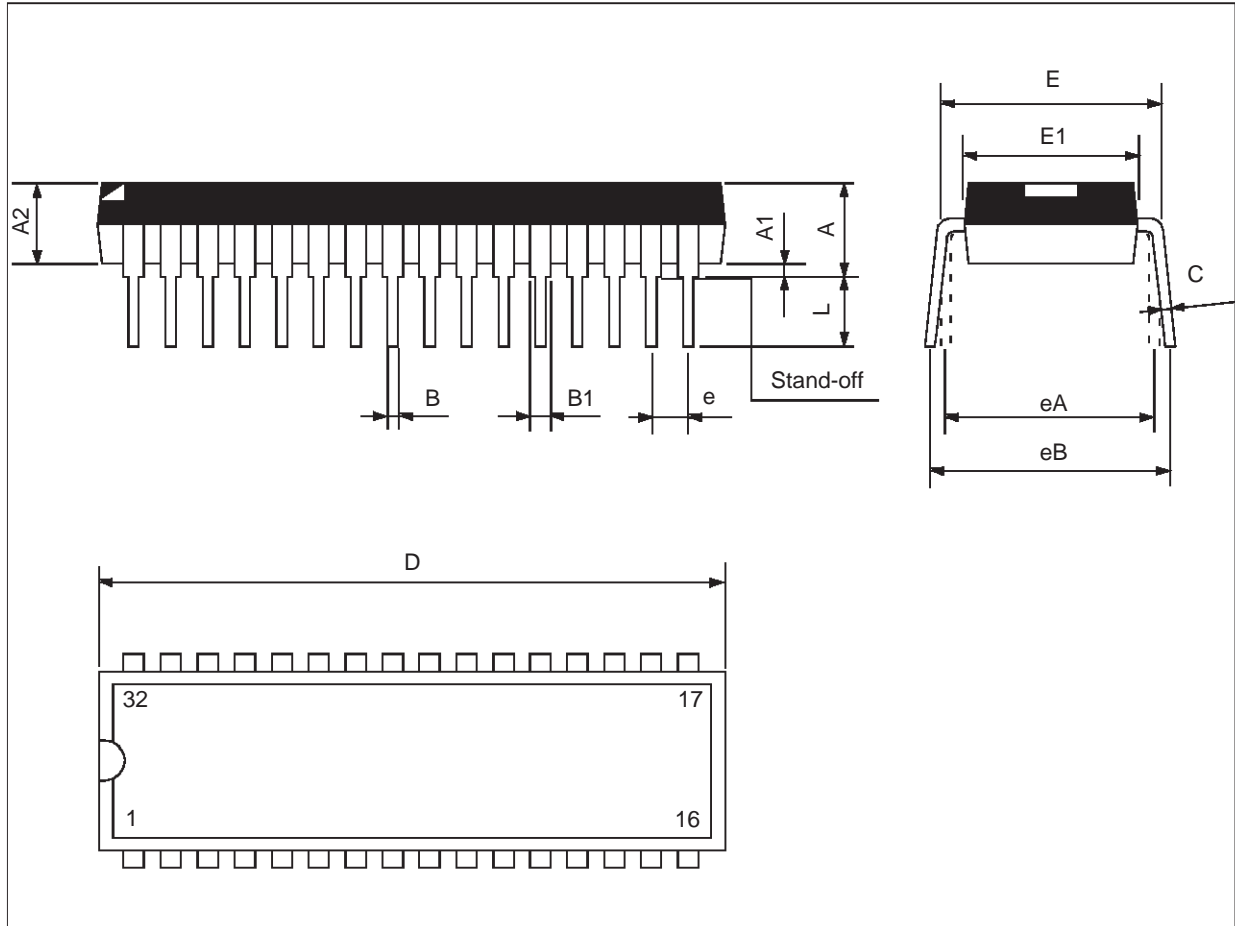

Figure 41. PCB Layout



PACKAGE MECHANICAL DATA

32 PINS - PLASTIC SHRINK



Dimensions	Millimeters			Inches		
	Min.	Typ.	Max.	Min.	Typ.	Max.
A	3.556	3.759	5.080	0.140	0.148	0.200
A1	0.508			0.020		
A2	3.048	3.556	4.572	0.120	0.140	0.180
B	0.356	0.457	0.584	0.014	0.018	0.023
B1	0.762	1.016	1.397	0.030	0.040	0.055
C	.203	0.254	0.356	0.008	0.010	0.014
D	27.43	27.94	28.45	1.080	1.100	1.120
E	9.906	10.41	11.05	0.390	0.410	0.435
E1	7.620	8.890	9.398	0.300	0.350	0.370
e		1.778			0.070	
eA		10.16			0.400	
eB			12.70			0.500
L	2.540	3.048	3.810	0.100	0.120	0.150

Information furnished is believed to be accurate and reliable. However, STMicroelectronics assumes no responsibility for the consequences of use of such information nor for any infringement of patents or other rights of third parties which may result from its use. No license is granted by implication or otherwise under any patent or patent rights of STMicroelectronics. Specifications mentioned in this publication are subject to change without notice. This publication supersedes and replaces all information previously supplied. STMicroelectronics products are not authorized for use as critical components in life support devices or systems without express written approval of STMicroelectronics.

The ST logo is a trademark of STMicroelectronics.

© 2000 STMicroelectronics - All Rights Reserved

Purchase of I²C Components of STMicroelectronics, conveys a license under the Philips I²C Patent. Rights to use these components in a I²C system, is granted provided that the system conforms to the I²C Standard Specifications as defined by Philips.

STMicroelectronics GROUP OF COMPANIES

Australia - Brazil - China - Finland - France - Germany - Italy - Japan - Korea - Malaysia - Malta - Mexico - Morocco - The Netherlands - Singapore - Spain - Sweden - Switzerland - Taiwan - Thailand - United Kingdom - U.S.A.

<http://www.st.com>