

DATA SHEET



PCA9537

4-bit I²C and SMBus low power I/O port
with interrupt and reset

Product data sheet
Supersedes data of 2004 Sep 30

2004 Nov 29



4-bit I²C and SMBus low power I/O port with interrupt and reset

PCA9537

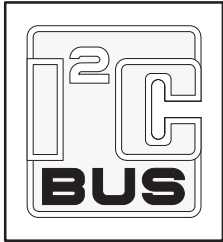

FEATURES

- 4-bit I²C GPIO with interrupt and reset
- Operating power supply voltage range of 2.3 to 5.5 V
- 5 V tolerant I/Os
- Polarity inversion register
- Active LOW interrupt output
- Active LOW reset input
- Low stand-by current
- Noise filter on SCL/SDA inputs
- No glitch on power-up
- Internal power-on reset
- 4 I/O pins which default to 4 inputs
- 0 kHz to 400 kHz clock frequency
- ESD protection exceeds 2000 V HBM per JESD22-A114, 200 V MM per JESD22-A115 and 1000 V CDM per JESD22-C101
- Latch-up testing is done to JEDEC Standard JESD78 which exceeds 100 mA
- Offered in TSSOP10 package

ORDERING INFORMATION

PACKAGES	TEMPERATURE RANGE	ORDER CODE	TOPSIDE MARK	DRAWING NUMBER
10-Pin Plastic TSSOP	-40 °C to +85 °C	PCA9537DP	9537	SOT552-1

Standard packing quantities and other packing data are available at www.standardproducts.philips.com/packaging.

I²C is a trademark of Philips Semiconductors Corporation.

SMBus as specified by the Smart Battery System Implementers Forum is a derivative of the Philips I²C patent.

DESCRIPTION

The PCA9537 is a 10-pin CMOS device that provide 4 bits of General Purpose parallel Input/Output (GPIO) expansion with interrupt and reset for I²C/SMBus applications and was developed to enhance the Philips family of I²C I/O expanders. I/O expanders provides a simple solution when additional I/O is needed for ACPI power switches, sensors, pushbuttons, LEDs, fans, etc.

The PCA9537 consists of a 4-bit Configuration register (Input or Output selection); 4-bit Input register, 4-bit Output register and a 4-bit Polarity inversion register (Active-HIGH or Active-LOW operation). The system master can enable the I/Os as either inputs or outputs by writing to the I/O configuration bits. The data for each Input or Output is kept in the corresponding Input or Output register. The polarity of the input port register can be inverted with the Polarity Inversion Register. All registers can be read by the system master.

The PCA9537 open-drain interrupt output is activated when any input state differs from its corresponding input port register state and is used to indicate to the system master that an input state has changed. The power-on reset sets the registers to their default values and initializes the device state machine. The RESET pin causes the same reset/initialization to occur without depowering the device.

The I²C address is fixed and allows only one device on the same I²C/SMBus.

4-bit I²C and SMBus low power I/O port with interrupt and reset

PCA9537

PIN CONFIGURATION

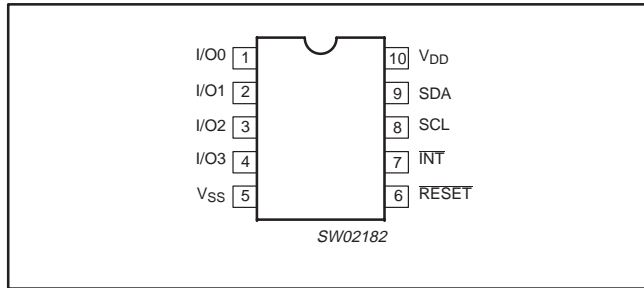

Figure 1. Pin configuration

PIN DESCRIPTION

PIN NUMBER	SYMBOL	FUNCTION
1–4	I/O0–3	I/O0 to I/O3
5	V _{SS}	Supply ground
6	RESET	Active LOW reset input
7	$\overline{\text{INT}}$	Interrupt output (open drain)
8	SCL	Serial clock line
9	SDA	Serial data line
10	V _{DD}	Supply voltage

BLOCK DIAGRAM

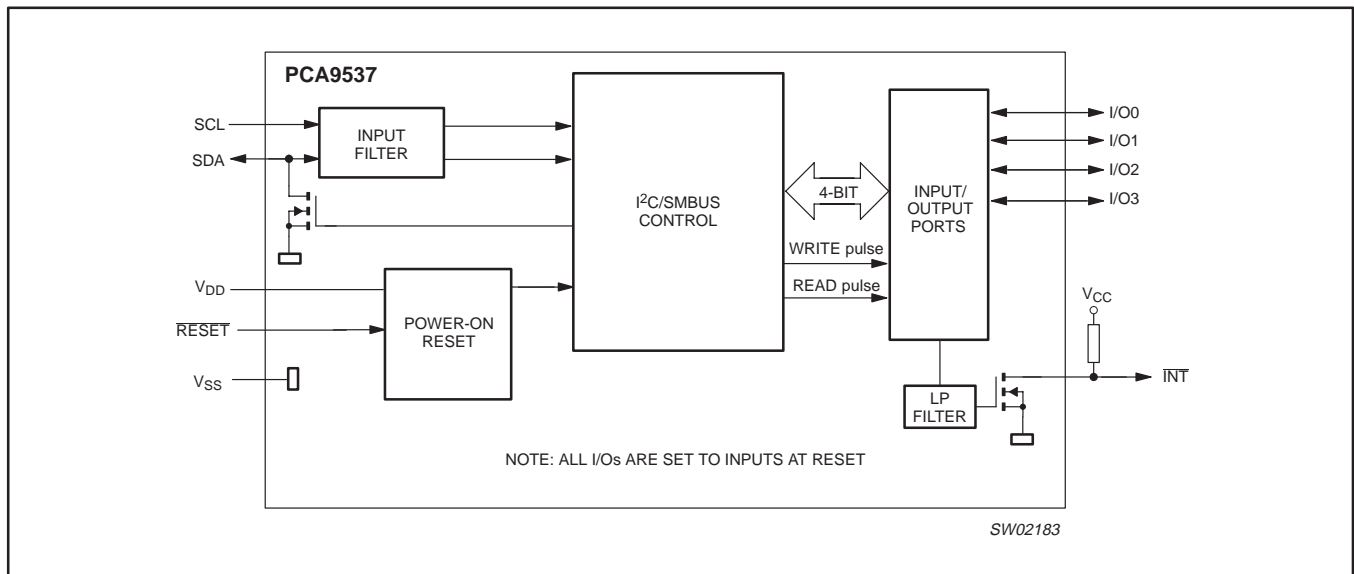

Figure 2. Block diagram

4-bit I²C and SMBus low power I/O port with interrupt and reset

PCA9537

REGISTERS

Command Byte

Command	Protocol	Function
0	Read byte	Input port register
1	Read/write byte	Output port register
2	Read/write byte	Polarity inversion register
3	Read/write byte	Configuration register

The command byte is the first byte to follow the address byte during a write transmission. It is used as a pointer to determine which of the following registers will be written or read.

Register 0 – Input Port Register

bit	I7	I6	I5	I4	I3	I2	I1	I0
	not used							
default	1	1	1	1	X	X	X	X

This register is a read only port. It reflects the incoming logic levels of the pins, regardless of whether the pin is defined as an input or an output by Register 3. Writes to this register have no effect.

The default value 'X' is determined by the externally applied logic level.

Register 1 – Output Port Register

bit	O7	O6	O5	O4	O3	O2	O1	O0
	not used							
default	1	1	1	1	1	1	1	1

This register reflects the outgoing logic levels of the pins defined as outputs by Register 3. Bit values in this register have no effect on pins defined as inputs. Reads from this register return the value that is in the flip-flop controlling the output selection, NOT the actual pin value.

Register 2 – Polarity Inversion Register

bit	N7	N6	N5	N4	N3	N2	N1	N0
	not used							
default	0	0	0	0	0	0	0	0

This register allows the user to invert the polarity of the Input Port Register data. If a bit in this register is set (written with '1'), the corresponding Input Port data is inverted. If a bit in this register is cleared (written with a '0'), the Input Port data polarity is retained.

Register 3 – Configuration Register

bit	C7	C6	C5	C4	C3	C2	C1	C0
	not used							
default	1	1	1	1	1	1	1	1

This register configures the directions of the I/O pins. If a bit in this register is set, the corresponding port pin is enabled as an input with high impedance output driver. If a bit in this register is cleared, the corresponding port pin is enabled as an output. At reset, the I/Os are configured as inputs.

Power-on Reset

When power is applied to V_{DD}, an internal power-on reset holds the PCA9537 in a reset condition until V_{DD} has reached V_{POR}. At that point, the reset condition is released and the PCA9537 registers and state machine will initialize to their default states. Thereafter, V_{DD} must be lowered below 0.2 V to reset the device.

For a power reset cycle, V_{DD} must be lowered below 0.2 V and then restored to the operating voltage.

RESET Input

A reset can be accomplished by holding the RESET pin LOW for a minimum of t_W. The PCA9537 registers and SMBus/I²C state machine will be held in their default state until the RESET input is once again HIGH. This input requires a pull-up resistor to V_{DD} if no active connection is used.

Interrupt Output

The open-drain interrupt output is activated when one of the port pins change state and the pin is configured as an input. The interrupt is deactivated when the input returns to its previous state or the input port register is read.

Note that changing an I/O from an output to an input may cause a false interrupt to occur if the state of the pin does not match the contents of the input port register.

4-bit I²C and SMBus low power I/O port with interrupt and reset

PCA9537

SIMPLIFIED SCHEMATIC OF I/O0 TO I/O3

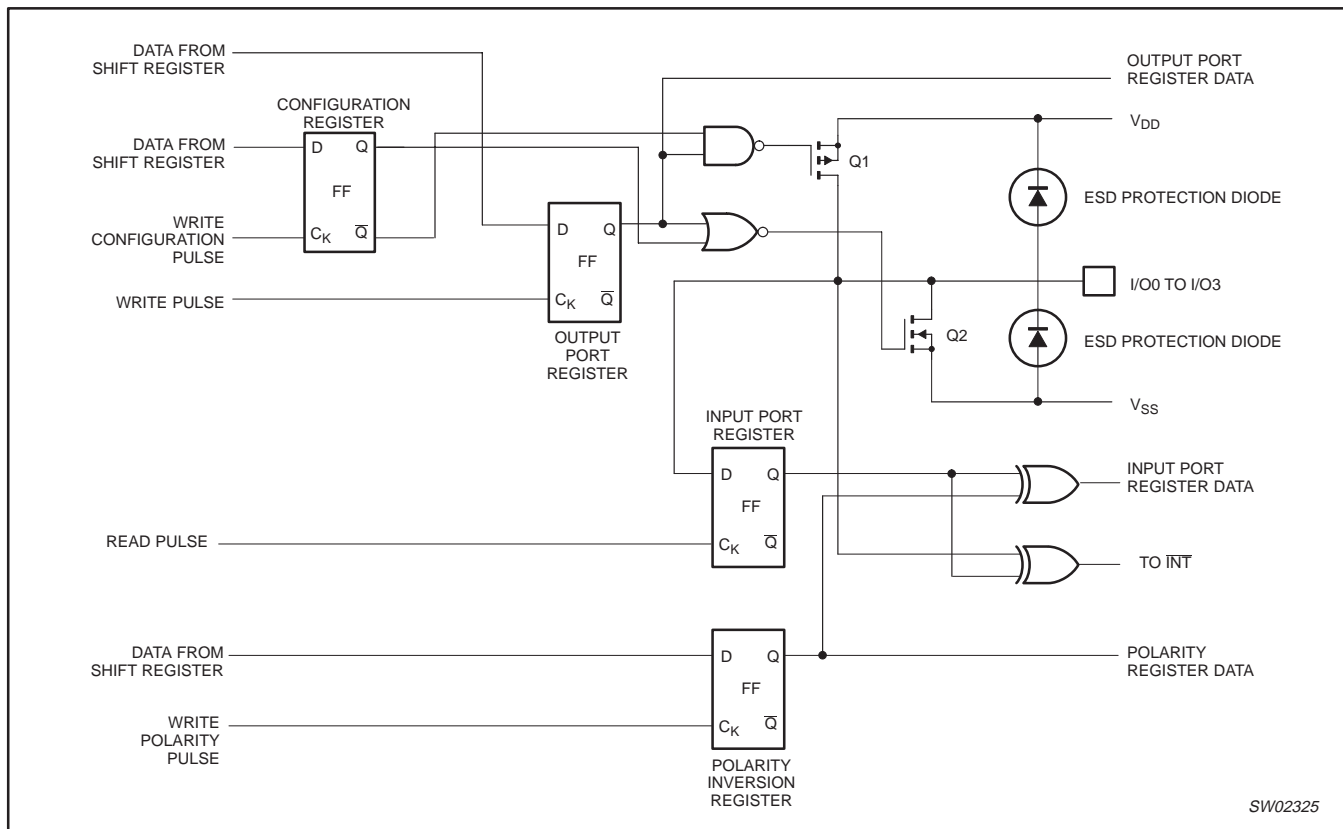

SW02325

NOTE: At Power-on Reset, all registers return to default values.

Figure 3. Simplified schematic of I/O0 to I/O3

I/O port

When an I/O is configured as an input, FETs Q1 and Q2 are off, creating a high-impedance input. The input voltage may be raised above V_{DD} to a maximum of 5.5 V.

If the I/O is configured as an output, then either Q1 or Q2 is enabled, depending on the state of the output port register. Care should be exercised if an external voltage is applied to an I/O configured as an output because of the low-impedance paths that exist between the pin and either V_{DD} or V_{SS}.

4-bit I²C and SMBus low power I/O port with interrupt and reset

PCA9537

Device address

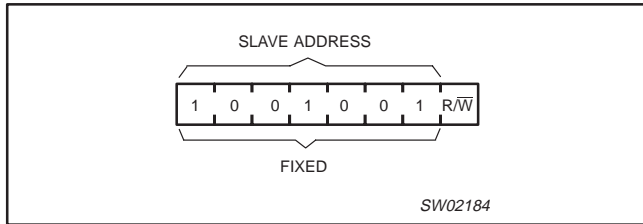

Figure 4. PCA9537 address

Bus transactions

Data is transmitted to the PCA9537 registers using the write mode as shown in Figures 5 and 6. Data is read from the PCA9537 registers using the read mode as shown in Figures 7 and 8. These devices do not implement an auto-increment function so once a command byte has been sent, the register which was addressed will continue to be accessed by reads until a new command byte has been sent.

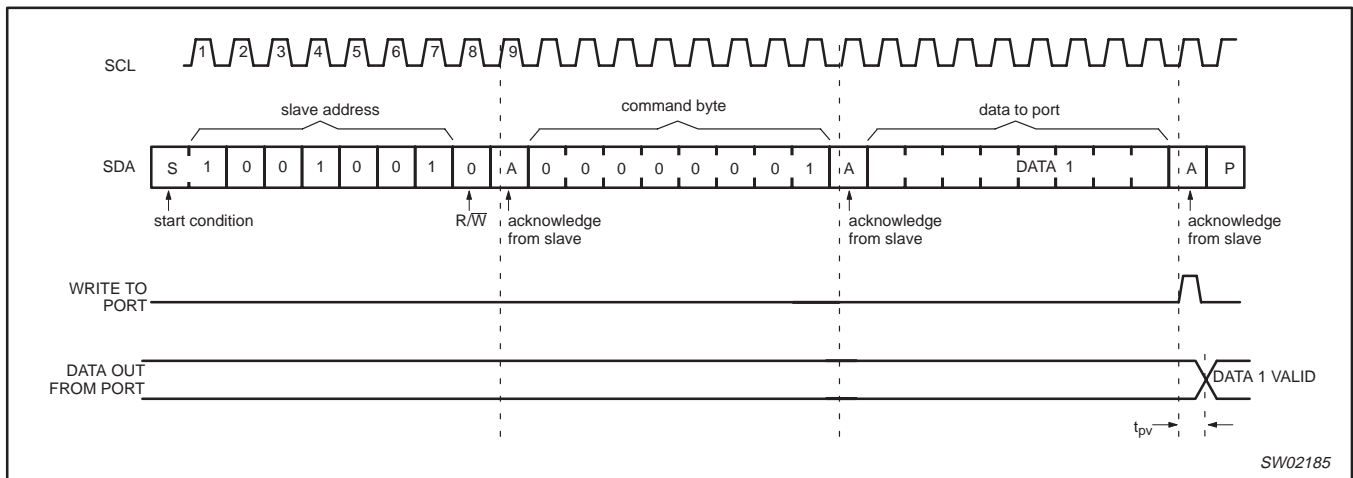

Figure 5. WRITE to output port register

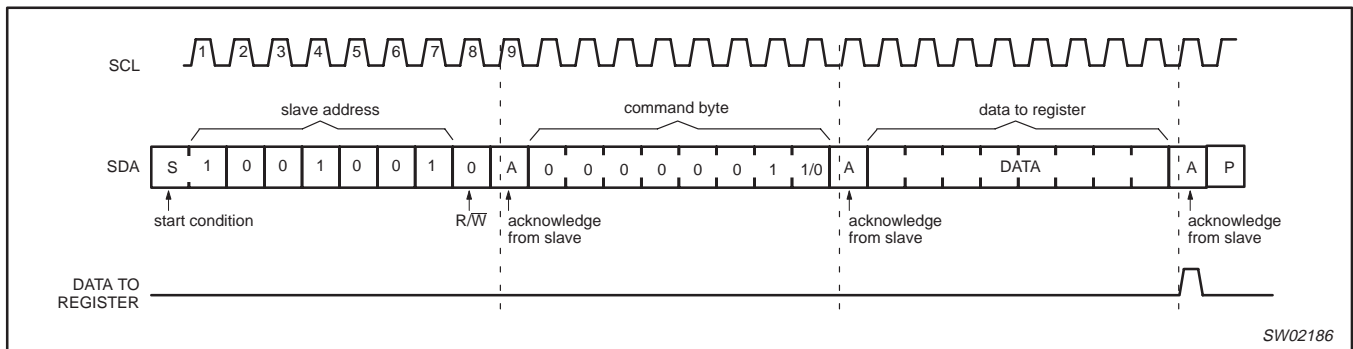

Figure 6. WRITE to configuration or polarity inversion registers

Expanded diagram found on page 13, Figure 16.

4-bit I²C and SMBus low power I/O port with interrupt and reset

PCA9537

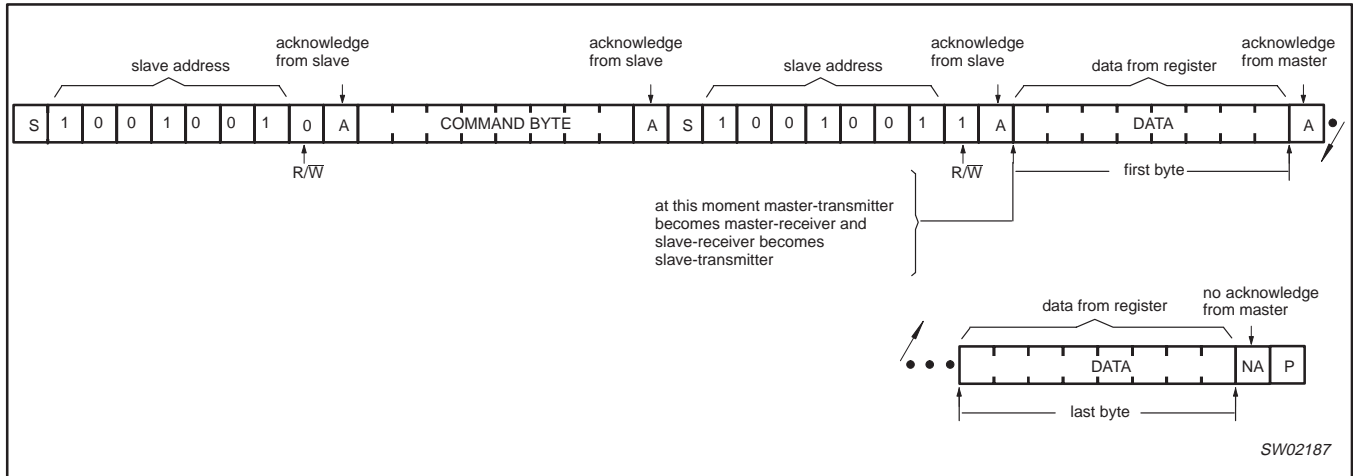
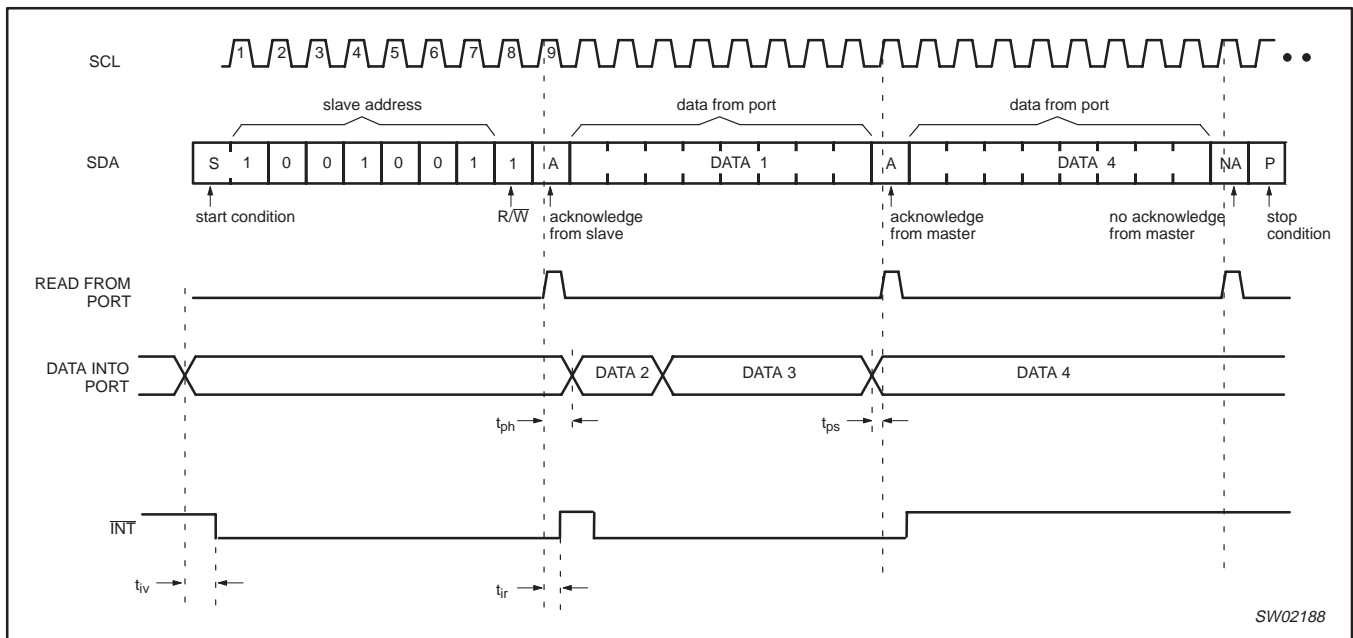

Figure 7. READ from register



NOTES:

1. This figure assumes the command byte has previously been programmed with 00h.
2. Transfer of data can be stopped at any moment by a stop condition.

Figure 8. READ input port register

Expanded diagram found on page 13, Figure 15.

4-bit I²C and SMBus low power I/O port with interrupt and reset

PCA9537

TYPICAL APPLICATION

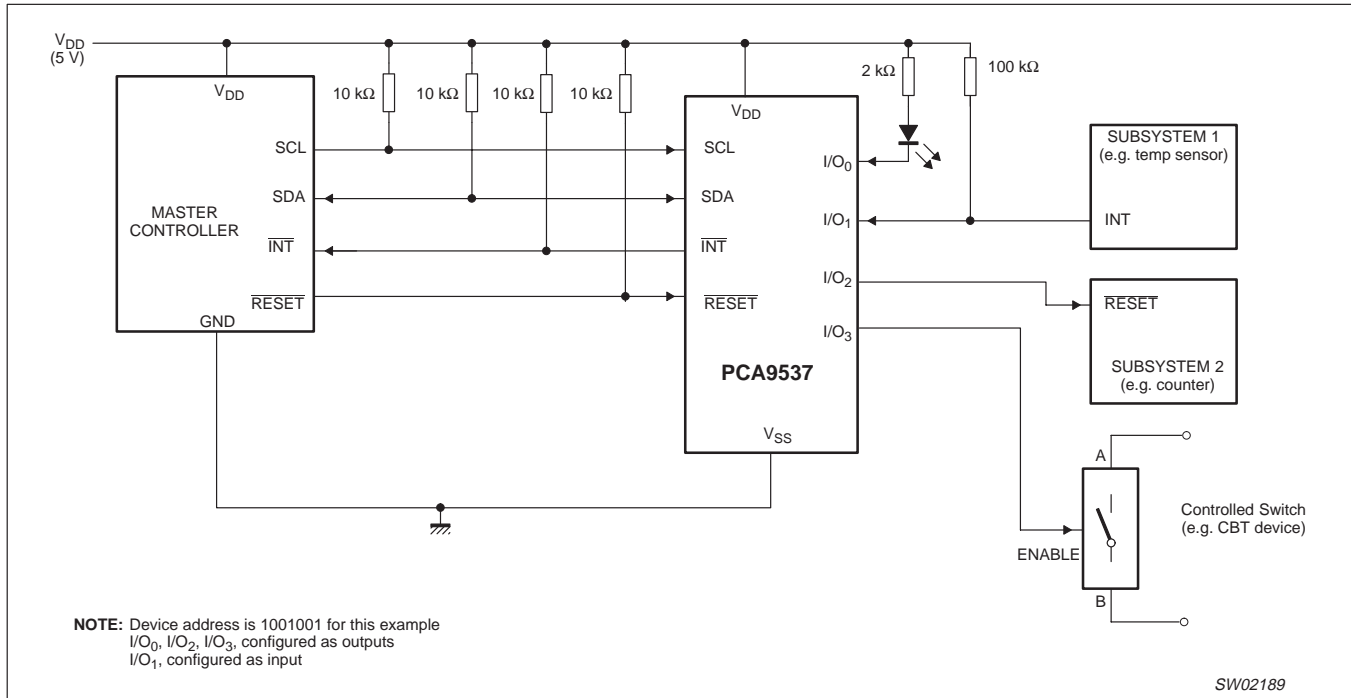

Figure 9. Typical application

Minimizing I_{DD} when the I/O is used to control LEDs

When the I/Os are used to control LEDs, they are normally connected to V_{DD} through a resistor as shown in Figure 9. Since the LED acts as a diode, when the LED is off the I/O V_{IN} is about 1.2 V less than V_{DD}. The supply current, I_{DD}, increases as V_{IN} becomes lower than V_{DD} and is specified as ΔI_{DD} in the DC characteristics table.

Designs needing to minimize current consumption, such as battery power applications, should consider maintaining the I/O pins greater than or equal to V_{DD} when the LED is off. Figure 10 shows a high value resistor in parallel with the LED. Figure 11 shows V_{DD} less than the LED supply voltage by at least 1.2 V. Both of these methods maintain the I/O V_{IN} at or above V_{DD} and prevents additional supply current consumption when the LED is off.

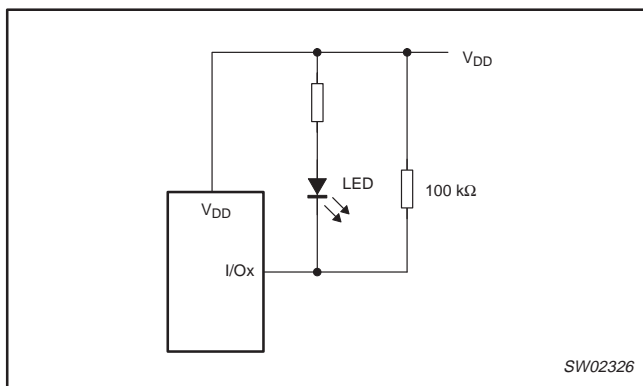

Figure 10. High value resistor in parallel with the LED

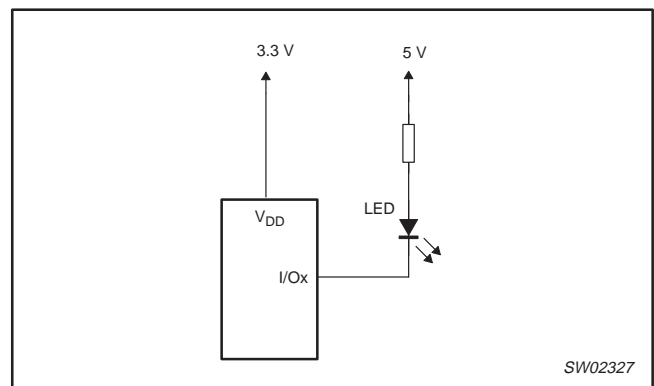

Figure 11. Device supplied by a lower voltage

**4-bit I²C and SMBus low power I/O port
with interrupt and reset**

PCA9537

ABSOLUTE MAXIMUM RATINGS

In accordance with the Absolute Maximum Rating System (IEC 134)

SYMBOL	PARAMETER	CONDITIONS	MIN	MAX	UNIT
V _{DD}	Supply voltage		-0.5	6.0	V
I _I	DC input current		—	±20	mA
V _{I/O}	DC voltage on an I/O		V _{SS} - 0.5	5.5	V
I _{I/O}	DC output current on an I/O		—	±50	mA
I _{DD}	Supply current		—	85	mA
I _{SS}	Supply current		—	100	mA
P _{tot}	Total power dissipation		—	200	mW
T _{stg}	Storage temperature range		-65	+150	°C
T _{amb}	Operating ambient temperature		-40	+85	°C
T _{J(MAX)}	Maximum junction temperature		—	+125	°C

4-bit I²C and SMBus low power I/O port with interrupt and reset

PCA9537

HANDLING

Inputs and outputs are protected against electrostatic discharge in normal handling. However, to be totally safe, it is desirable to take precautions appropriate to handling MOS devices. Advice can be found in Data Handbook IC24 under "Handling MOS devices".

DC CHARACTERISTICS

$V_{DD} = 2.3$ to 5.5 V; $V_{SS} = 0$ V; $T_{amb} = -40$ °C to $+85$ °C; unless otherwise specified.

SYMBOL	PARAMETER	CONDITIONS	MIN	TYP	MAX	UNIT
Supplies						
V_{DD}	Supply voltage		2.3	—	5.5	V
I_{DD}	Supply current	Operating mode; $V_{DD} = 5.5$ V; no load; $f_{SCL} = 100$ kHz	—	104	175	μ A
I_{stbl}	Standby current	Standby mode; $V_{DD} = 5.5$ V; no load; $V_I = V_{SS}$; $f_{SCL} = 0$ kHz; I/O = inputs	—	0.25	1	μ A
I_{stbh}	Standby current	Standby mode; $V_{DD} = 5.5$ V; no load; $V_I = V_{DD}$; $f_{SCL} = 0$ kHz; I/O = inputs	—	0.25	1	μ A
V_{POR}	Power-on reset voltage (Note 1)	No load; $V_I = V_{DD}$ or V_{SS}	—	1.5	1.65	V
Input SCL; input/output SDA						
V_{IL}	LOW-level input voltage		-0.5	—	$0.3V_{DD}$	V
V_{IH}	HIGH-level input voltage		$0.7V_{DD}$	—	5.5	V
I_{OL}	LOW-level output current	$V_{OL} = 0.4$ V	3	7	—	mA
I_L	Leakage current	$V_I = V_{DD} = V_{SS}$	-1	—	+1	μ A
C_I	Input capacitance	$V_I = V_{SS}$	—	5	10	pF
I/Os						
V_{IL}	LOW-level input voltage		-0.5	—	0.8	V
V_{IH}	HIGH-level input voltage		2.0	—	5.5	V
I_{OL}	LOW-level output current	$V_{OL} = 0.5$ V; $V_{DD} = 2.3$ V; Note 2	8	10	—	mA
		$V_{OL} = 0.7$ V; $V_{DD} = 2.3$ V; Note 2	10	13	—	mA
		$V_{OL} = 0.5$ V; $V_{DD} = 4.5$ V; Note 2	8	17	—	mA
		$V_{OL} = 0.7$ V; $V_{DD} = 4.5$ V; Note 2	10	24	—	mA
		$V_{OL} = 0.5$ V; $V_{DD} = 3.0$ V; Note 2	8	14	—	mA
		$V_{OL} = 0.7$ V; $V_{DD} = 3.0$ V; Note 2	10	19	—	mA
V_{OH}	HIGH-level output voltage	$I_{OH} = -8$ mA; $V_{DD} = 2.3$ V; Note 3	1.8	—	—	V
		$I_{OH} = -10$ mA; $V_{DD} = 2.3$ V; Note 3	1.7	—	—	V
		$I_{OH} = -8$ mA; $V_{DD} = 3.0$ V; Note 3	2.6	—	—	V
		$I_{OH} = -10$ mA; $V_{DD} = 3.0$ V; Note 3	2.5	—	—	V
		$I_{OH} = -8$ mA; $V_{DD} = 4.5$ V; Note 3	4.1	—	—	V
		$I_{OH} = -10$ mA; $V_{DD} = 4.5$ V; Note 3	4.0	—	—	V
I_L	Leakage current	$V_I = V_{DD} = V_{SS}$	-1	—	1	μ A
C_I	Input capacitance		—	5	10	pF
Interrupt INT						
I_{OL}	LOW-level output current	$V_{OL} = 0.4$ V	3	13	—	mA
I_{OH}	HIGH-level output current	$V_{OL} = 0.4$ V	-1	—	+1	μ A
Select Input RESET						
V_{IL}	LOW-level input voltage		-0.5	—	0.8	V
V_{IH}	HIGH-level input voltage		2.0	—	5.5	V
I_L	Leakage current	$V_I = V_{DD} = V_{SS}$	-1	—	1	μ A

NOTES:

- V_{DD} must be lowered to 0.2 V in order to reset part.
- Each I/O must be externally limited to a maximum of 25 mA and the device must be limited to a maximum current of 100 mA.
- The total current sourced by all I/Os must be limited to 85 mA.

4-bit I²C and SMBus low power I/O port with interrupt and reset

PCA9537

AC SPECIFICATIONS

SYMBOL	PARAMETER	STANDARD MODE I ² C-bus		FAST MODE I ² C-bus		UNITS
		MIN	MAX	MIN	MAX	
f _{SCL}	Operating frequency	0	100	0	400	kHz
t _{BUF}	Bus free time between STOP and START conditions	4.7	—	1.3	—	μs
t _{HD;STA}	Hold time after (repeated) START condition	4.0	—	0.6	—	μs
t _{SU;STA}	Repeated START condition setup time	4.7	—	0.6	—	μs
t _{SU;STO}	Setup time for STOP condition	4.0	—	0.6	—	μs
t _{HD;DAT}	Data in hold time	0	—	0	—	ns
t _{VD;ACK}	Valid time for ACK condition ²	0.3	3.45	0.1	0.9	μs
t _{VD;DAT}	Data out valid time ³	300	—	50	—	ns
t _{SU;DAT}	Data setup time	250	—	100	—	ns
t _{LOW}	Clock LOW period	4.7	—	1.3	—	μs
t _{HIGH}	Clock HIGH period	4.0	—	0.6	—	μs
t _F	Clock/Data fall time	—	300	20 + 0.1 C _b ¹	300	ns
t _R	Clock/Data rise time	—	1000	20 + 0.1 C _b ¹	300	ns
t _{SP}	Pulse width of spikes that must be suppressed by the input filters	—	50	—	50	ns
Port Timing						
t _{PV}	Output data valid	—	200	—	200	ns
t _{PS}	Input data setup time	100	—	100	—	ns
t _{PH}	Input data hold time	1	—	1	—	μs
Interrupt Timing						
t _{IV}	Interrupt valid	—	4	—	4	μs
t _{IR}	Interrupt reset	—	4	—	4	μs
RESET						
t _W	Reset pulse width	4	—	4	—	ns
t _{REC}	Reset recovery time	0	—	0	—	ns
t _{RESET}	Time to reset	400	—	400	—	ns

NOTES:

1. C_b = total capacitance of one bus line in pF.
2. t_{VD;ACK} = time for Acknowledgement signal from SCL LOW to SDA (out) LOW.
3. t_{VD;DAT} = minimum time for SDA data out to be valid following SCL LOW.

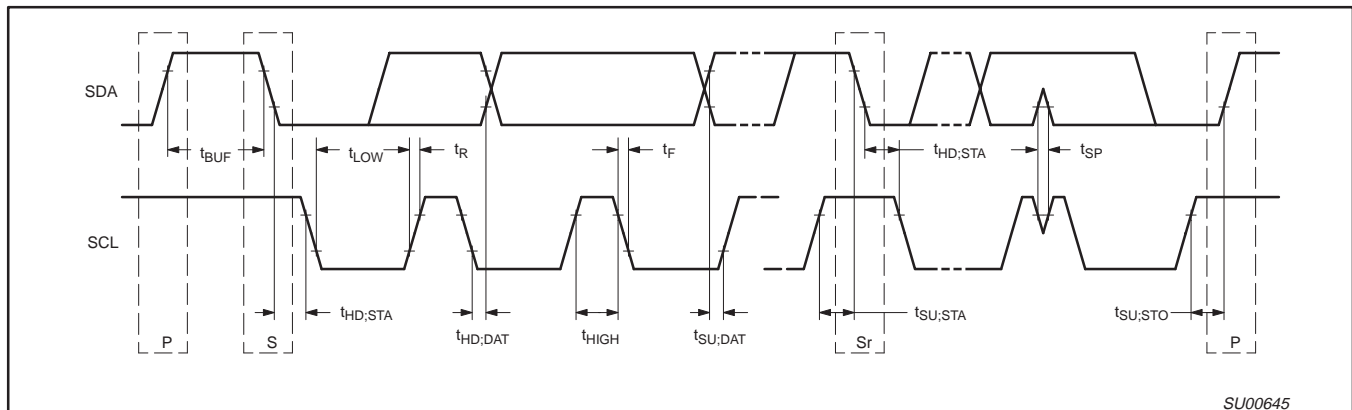

Figure 12. Definition of timing

SU00645

4-bit I²C and SMBus low power I/O port with interrupt and reset

PCA9537

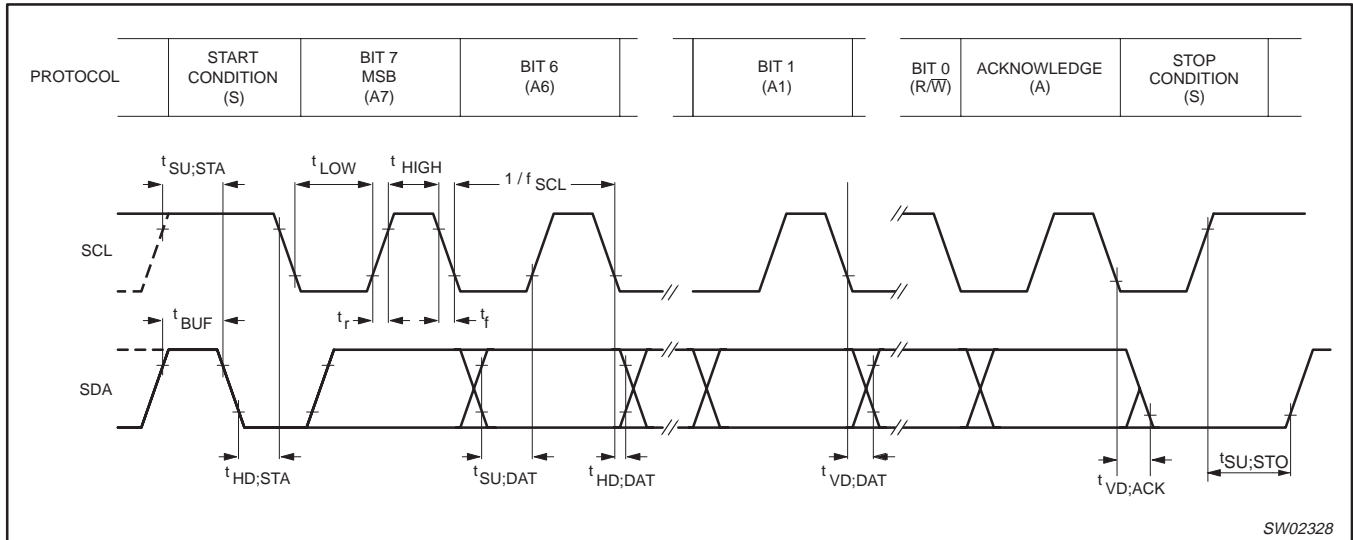

Figure 13. I²C-bus timing diagram; rise and fall times refer to V_{IL} and V_{IH}

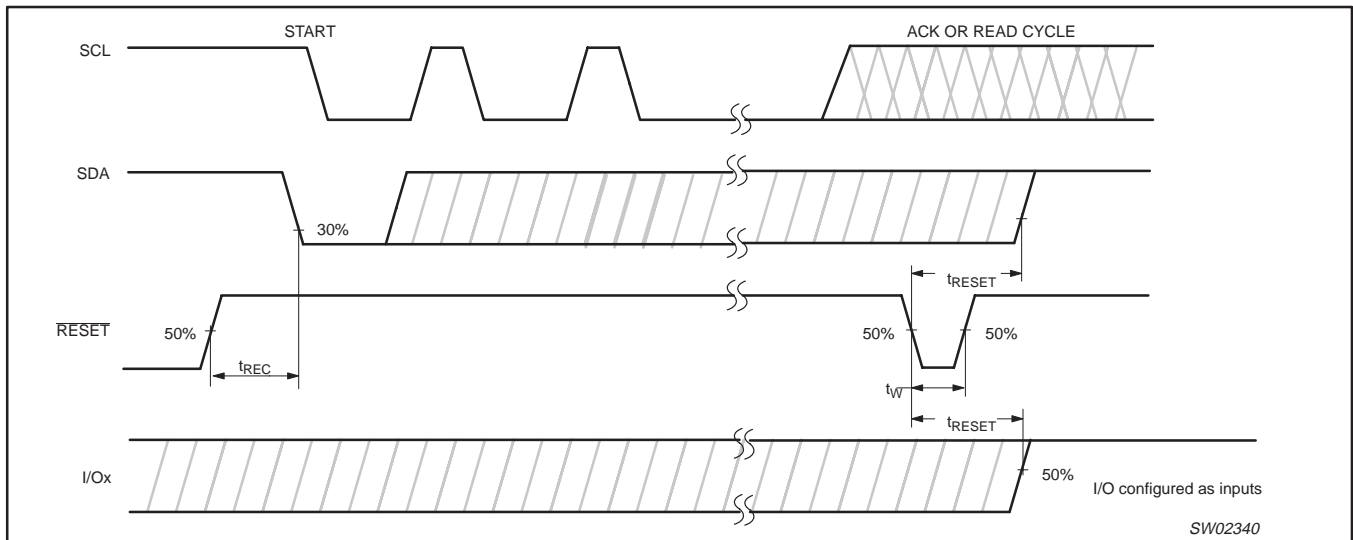

Figure 14. Definition of RESET timing

4-bit I²C and SMBus low power I/O port with interrupt and reset

PCA9537

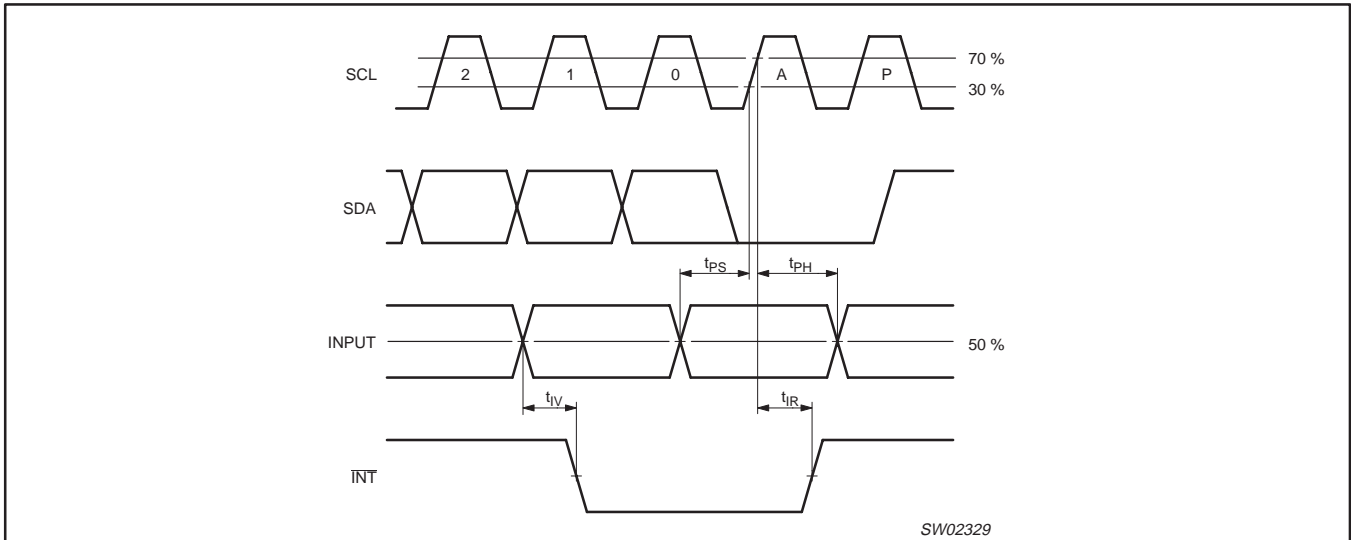

Figure 15. Expanded view of Read input port register

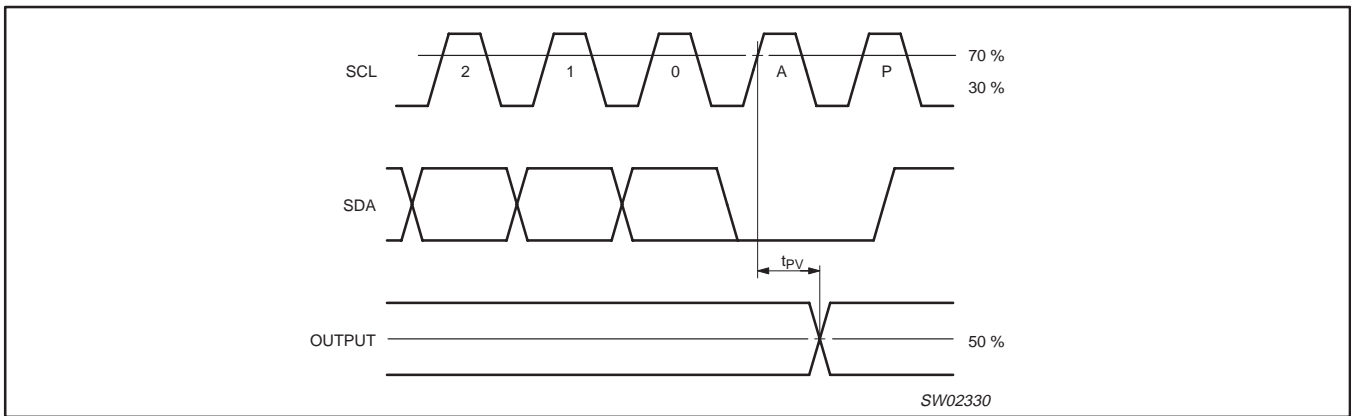

Figure 16. Expanded view of Write to output port register

4-bit I²C and SMBus low power I/O port with interrupt and reset

PCA9537

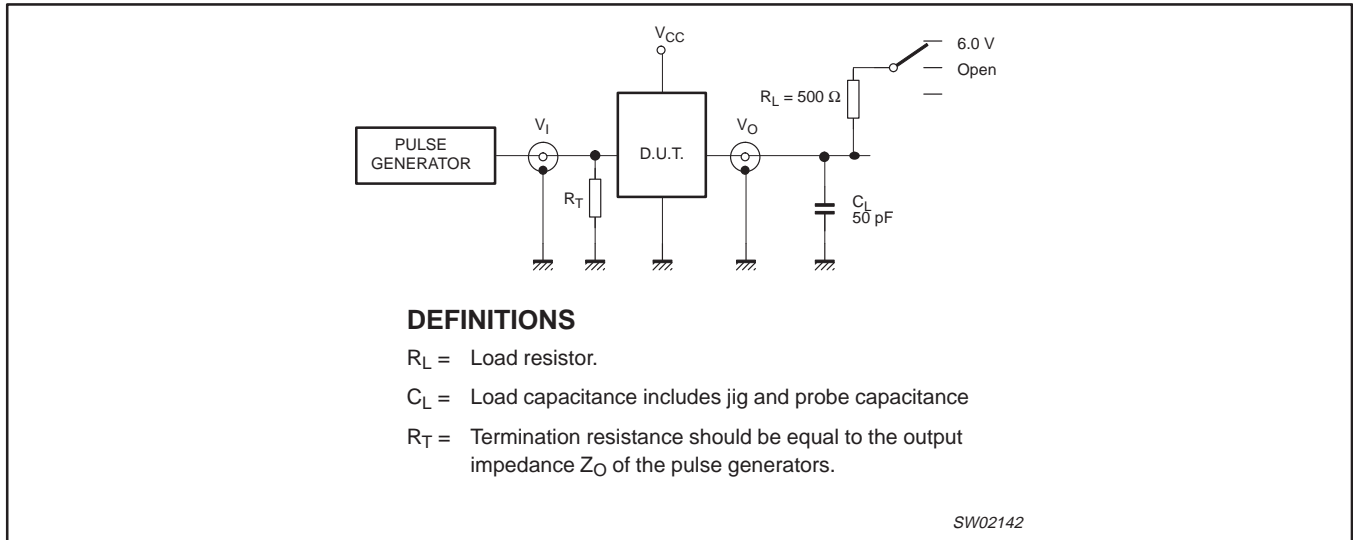

Figure 17. Test circuitry for switching times

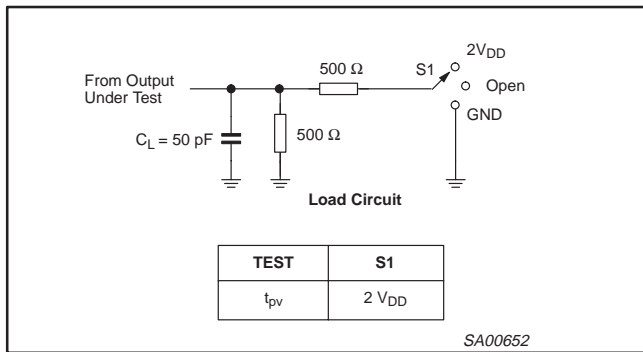

Figure 18. Test circuit

4-bit I²C and SMBus low power I/O port
with interrupt and reset

PCA9537

TSSOP10: plastic thin shrink small outline package; 10 leads, body width 3 mm

SOT552-1

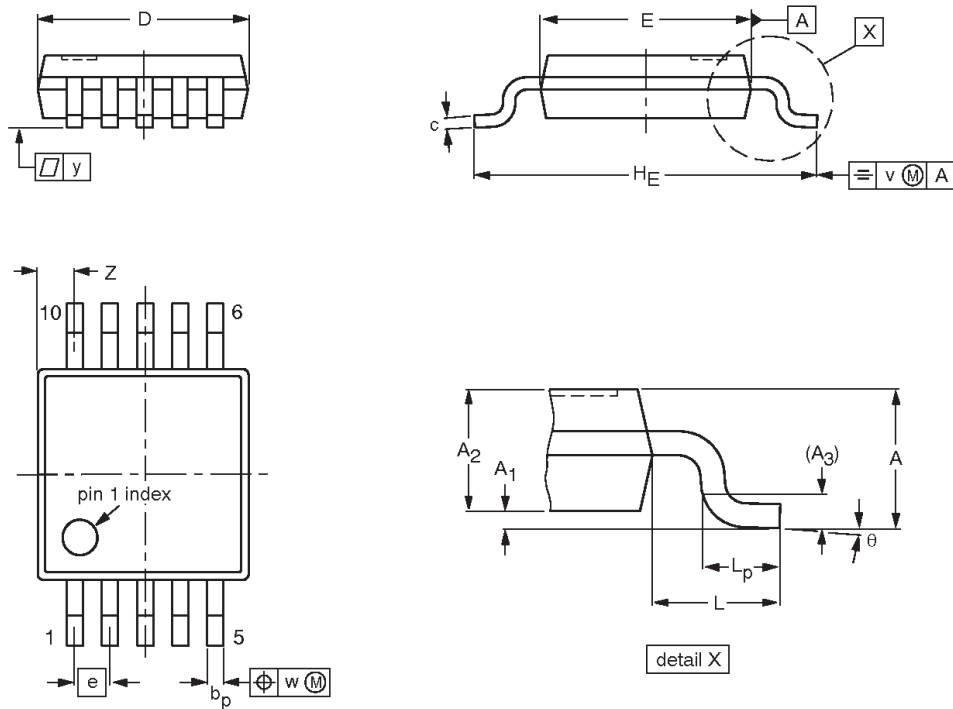

DIMENSIONS (mm are the original dimensions)

UNIT	A max.	A ₁	A ₂	A ₃	b _p	c	D ⁽¹⁾	E ⁽²⁾	e	H _E	L	L _p	v	w	y	Z ⁽¹⁾	θ
mm	1.1	0.15 0.05	0.95 0.80	0.25	0.30 0.15	0.23 0.15	3.1 2.9	3.1 2.9	0.5	5.0 4.8	0.95	0.7 0.4	0.1	0.1	0.1	0.67 0.34	6° 0°

Notes

1. Plastic or metal protrusions of 0.15 mm maximum per side are not included.
2. Plastic or metal protrusions of 0.25 mm maximum per side are not included.

OUTLINE VERSION	REFERENCES				EUROPEAN PROJECTION	ISSUE DATE
	IEC	JEDEC	JEITA			
SOT552-1						99-07-29 03-02-18

**4-bit I²C and SMBus low power I/O port
with interrupt and reset**

PCA9537

REVISION HISTORY

Rev	Date	Description
3	20041129	Product data sheet (9397 750 14259). Supersedes data of 2004 Sep 30 (9397 750 14052). Modifications: <ul style="list-style-type: none">• DC Characteristics table on page 10:<ul style="list-style-type: none">– subsection 'I/Os': changed symbol "I{IL}" to "I_L" and parameter from "Input leakage current" to "Leakage current"– subsection 'Input SCL; input/output SDA': change I_{OL(typ)} from 'tdb' to '7 mA'– subsection 'Interrupt INT': added "I_{OL}" characteristic– subsection 'Select Input RESET': changed symbol "I_{IL}" to "I_L" and parameter from "Input leakage current" to "Leakage current" added condition "V_I = V_{DD} = V_{SS}"
_2	20040930	Objective data sheet (9397 750 14052). Supersedes data of 2004 Aug 20 (9397 750 12894).
_1	20040820	Objective data sheet (9397 750 12894).

4-bit I²C and SMBus low power I/O port with interrupt and reset

PCA9537



Purchase of Philips I²C components conveys a license under the Philips' I²C patent to use the components in the I²C system provided the system conforms to the I²C specifications defined by Philips. This specification can be ordered using the code 9398 393 40011.

Data sheet status

Level	Data sheet status [1]	Product status [2] [3]	Definitions
I	Objective data sheet	Development	This data sheet contains data from the objective specification for product development. Philips Semiconductors reserves the right to change the specification in any manner without notice.
II	Preliminary data sheet	Qualification	This data sheet contains data from the preliminary specification. Supplementary data will be published at a later date. Philips Semiconductors reserves the right to change the specification without notice, in order to improve the design and supply the best possible product.
III	Product data sheet	Production	This data sheet contains data from the product specification. Philips Semiconductors reserves the right to make changes at any time in order to improve the design, manufacturing and supply. Relevant changes will be communicated via a Customer Product/Process Change Notification (CPCN).

[1] Please consult the most recently issued data sheet before initiating or completing a design.

[2] The product status of the device(s) described in this data sheet may have changed since this data sheet was published. The latest information is available on the Internet at URL <http://www.semiconductors.philips.com>.

[3] For data sheets describing multiple type numbers, the highest-level product status determines the data sheet status.

Definitions

Short-form specification — The data in a short-form specification is extracted from a full data sheet with the same type number and title. For detailed information see the relevant data sheet or data handbook.

Limiting values definition — Limiting values given are in accordance with the Absolute Maximum Rating System (IEC 60134). Stress above one or more of the limiting values may cause permanent damage to the device. These are stress ratings only and operation of the device at these or at any other conditions above those given in the Characteristics sections of the specification is not implied. Exposure to limiting values for extended periods may affect device reliability.

Application information — Applications that are described herein for any of these products are for illustrative purposes only. Philips Semiconductors make no representation or warranty that such applications will be suitable for the specified use without further testing or modification.

Disclaimers

Life support — These products are not designed for use in life support appliances, devices, or systems where malfunction of these products can reasonably be expected to result in personal injury. Philips Semiconductors customers using or selling these products for use in such applications do so at their own risk and agree to fully indemnify Philips Semiconductors for any damages resulting from such application.

Right to make changes — Philips Semiconductors reserves the right to make changes in the products—including circuits, standard cells, and/or software—described or contained herein in order to improve design and/or performance. When the product is in full production (status 'Production'), relevant changes will be communicated via a Customer Product/Process Change Notification (CPCN). Philips Semiconductors assumes no responsibility or liability for the use of any of these products, conveys no license or title under any patent, copyright, or mask work right to these products, and makes no representations or warranties that these products are free from patent, copyright, or mask work right infringement, unless otherwise specified.

Contact information

For additional information please visit

<http://www.semiconductors.philips.com>. Fax: +31 40 27 24825

© Koninklijke Philips Electronics N.V. 2004
All rights reserved. Printed in U.S.A.

Date of release: 11-04

For sales offices addresses send e-mail to:

sales.addresses@www.semiconductors.philips.com

Document order number:

9397 750 14259

Let's make things better.