



TDA9533

7.5NS TRIPLE HIGH VOLTAGE VIDEO AMPLIFIER

PRELIMINARY DATA

FEATURE

- ✦ TRIPLE CHANNEL VIDEO AMPLIFIER
- ✦ SUPPORTS DC OR AC COUPLING APPLICATIONS
- ✦ BUILT IN VOLTAGE GAIN: 20
- ✦ RISE AND FALL TIMES: 7.5ns TYPICAL
- ✦ BANDWIDTH: 50MHz TYPICAL
- ✦ SUPPLY VOLTAGE: 110V
- ✦ ADDITIONAL CUT-OFF INPUT CONTROL

DESCRIPTION

The TDA9533 is a triple video amplifier with high voltage Bipolar/CMOS/DMOS technology (BCD). It can drive the 3 cathodes of a monitor CRT in DC or AC coupling mode. A DC coupling application is obtained by connecting a triple DC controlled circuit either on the input pin or on the cut-off pin.

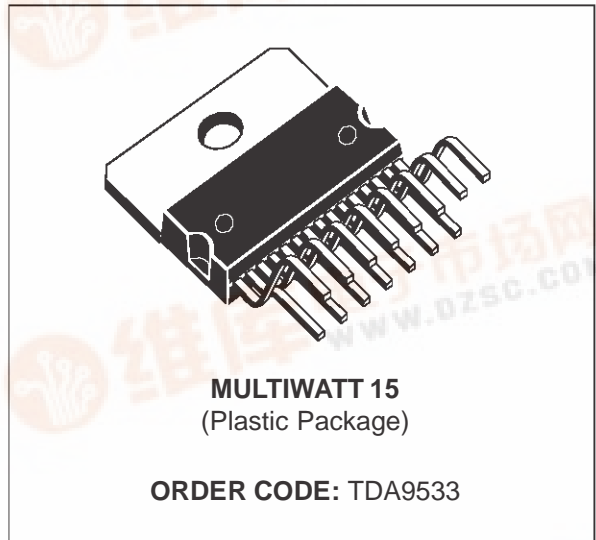

PIN CONNECTIONS

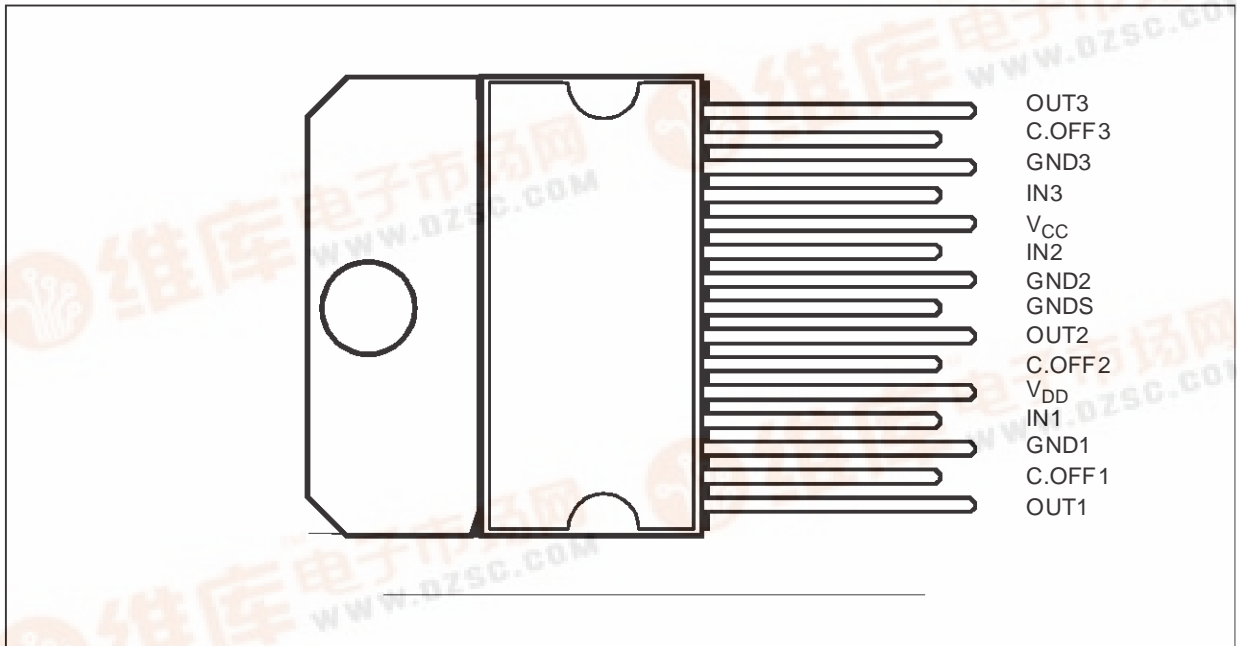

BLOCK DIAGRAM

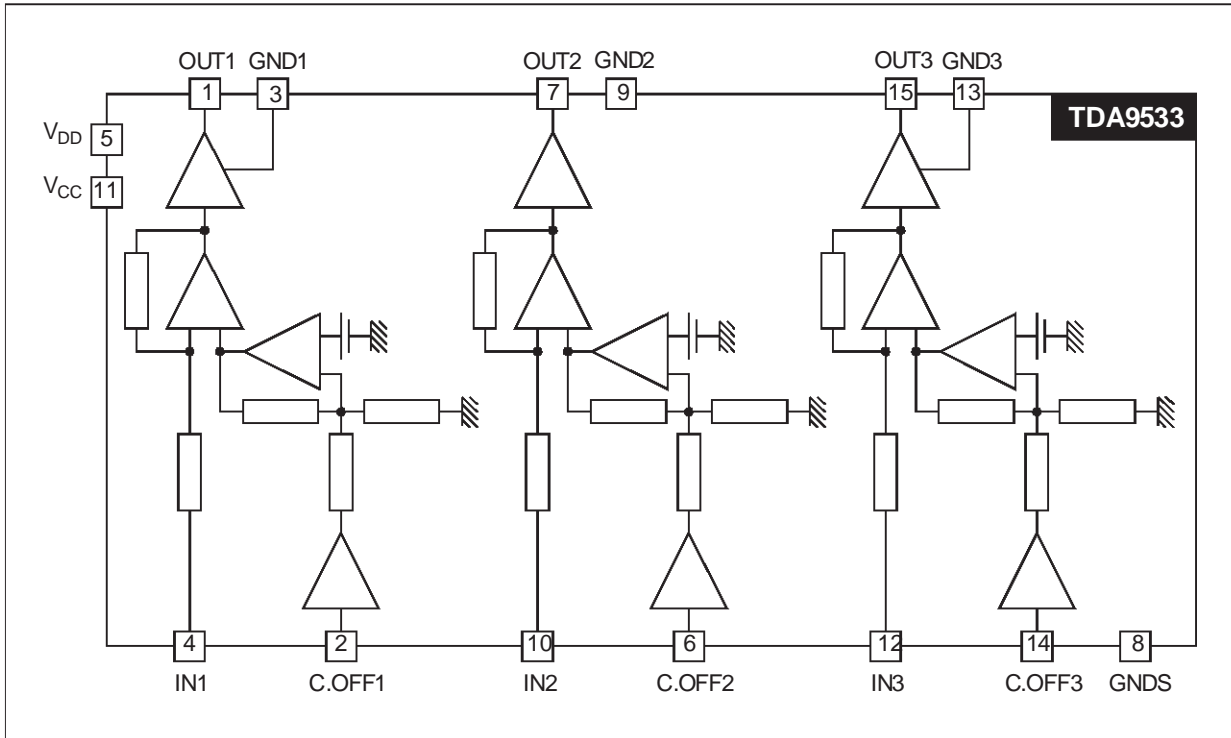

ABSOLUTE MAXIMUM RATINGS

Symbol	Parameter	Value	Unit
V _{DD}	High Supply Voltage	120	V
V _{CC}	Low Supply Voltage	17	V
V _{ESD}	ESD Susceptibility Human Body Model, 100pF. Discharge through 1.5KΩ EIAJ Norm, 200pF. Discharge through 0Ω	2	kV
		300	V
I _{OD}	Output Source Current (pulsed < 50μs)	80	mA
I _{OG}	Output Sink Current (pulsed < 50μs)	80	mA
V _{I Max}	Maximum Input Voltage	15	V
V _{I Min}	Minimum Input Voltage	- 0.5	V
V _{IC OFF Max}	Maximum C. off Input Voltage	V _{CC} + 0.5	V
V _{IC OFF Min}	Minimum C. off Input Voltage	- 0.5	V
T _J	Junction Temperature	150	°C
T _{STG}	Storage Temperature	-20 + 150	°C

THERMAL DATA

Symbol	Parameter	Value	Unit
R _{th (j-c)}	Junction-Case Thermal Resistance (Max.)	3	°C/W
R _{th (j-a)}	Junction-Ambient Thermal Resistance (Typ.)	35	°C/W

ELECTRICAL CHARACTERISTICS

(VCC = 12V, VC OFF = 2.5V, VDD = 110V, Tamb = 25 °C, unless otherwise specified)

Symbol	Parameter	Test Conditions	Min	Typ	Max	Unit
V _{DD}	High Supply Voltage (Pin 5)		20	110	115	V
V _{CC}	Low Supply Voltage (Pin 11)		10	12	15	V
I _{DD} I _{CC}	High Voltage Supply Internal DC Current Low Voltage Supply Internal DC Current	V _{OUT} = 50V		25 60		mA mA
dV _{OUT} /dV _{DD}	High Voltage Supply Rejection	V _{OUT} = 50V		0.5		%
dV _{OUT} /dθ	Output Voltage Drift Versus Temperature for any Channel	V _{OUT} = 80V		15		mV/ °C
dΔV _{OUT} /dθ	Differential Output Voltage Offset Drift Versus Temperature	V _{OUT} = 80V		5		mV/ °C
$\frac{\Delta V_{OUT}}{\Delta V_{C.OFF}}$	Cut-Off Control Gain	V _{OUT} = 80V 1V < V _{C OFF} < 4V		14		
I _{BC .OFF}	Cut-Off Control Bias Current	V _{OUT} = 80V			10	μA
V _{OUT SATH} V _{OUT SATL}	Max. Output Voltage Min. Output Voltage	I ₀ = -60mA, (1) I ₀ = 60mA, (1)		V _{DD} - 6.5 11		V V
AV _R	Typical Video Gain	V _{OUT} = 50V		20		
E _{lin}	Linearity Error	17 < V _{OUT} < V _{DD} - 15V		5	8	%
OS	Overshoot			5		%
Lf Δg/g	Low Frequency Gain Matching	V _{OUT} = 50V, f=1MHz			5	%
R _{IN}	Video Input Resistor	V _{OUT} = 50V		2		KΩ
BW	Bandwidth at -3dB	V _{OUT} =50V, C _{LOAD} =8pF R _P =200Ω, ΔV _{OUT} =20V		50		MHz
t _R , t _F	Rise and Fall Time	V _{OUT} =50V, C _{LOAD} =8pF R _P =200Ω, ΔV _{OUT} =40V		7.5		ns
t _{SET}	2.5% Settling Time	V _{OUT} =50V, C _{LOAD} =8pF R _P =200Ω, ΔV _{OUT} =40V		15		ns
Lf CT Hf CT	Low Frequency Crosstalk High Frequency Crosstalk	V _{OUT} =50V, C _{LOAD} =8pF R _P =200 Ω, ΔV _{OUT} =20V f = 1 MHz f = 20MHz		50 32		dB dB

Note: 1 Pulsed current width < 50μs

TYPICAL APPLICATION

PC Board Lay-out

The best performance is obtained with a carefully designed HF PC board, especially for the output and input capacitors.

Rise/fall time and bandwidth are measured on a 8pF load (including a PC board parasitical, socket and a CRT capacitor).

The input voltage range for the cut-off adjustment pins is from 1 to 4 volts and a 10 nF to 47 nF bypass capacitor is recommended on these pins.

Power Dissipation

The power dissipation is the sum of the DC and the dynamic dissipation.

As the feedback resistors are integrated, the DC power dissipation (capacitive load) can be estimated by:

$$P_{STAT} = V_{DD} \cdot I_{DD} + V_{CC} \cdot I_{CC}$$

The dynamic dissipation in worst case (full bandwidth and black pixel/white pixel picture - (2) is:

$$P_{DYN} = 3 V_{DD} \cdot C_L \cdot V_{OUT(PP)} \cdot f \cdot K$$

where f is the video frequency and K the active line duration / total duration.

Example: for $V_{DD} = 110V$, $V_{CC} = 12V$, $V_{OUT} = 40 V_{PP}$, $I_{DD} = 25mA$, $I_{CC} = 60mA$, $f_{VIDEO} = 40MHz$, $C_L = 8pF$ and $K = 0.72$.

We have: $P_{STAT} = 3.47W$ and $P_{DYN} = 3.04W$

Therefore: $P_{tot} = 6.51W$.

Note: 2 This worst thermal case must only be considered for T_{Jmax} calculation. Nevertheless, during the average life of the circuit, the conditions are very close to the white picture conditions.

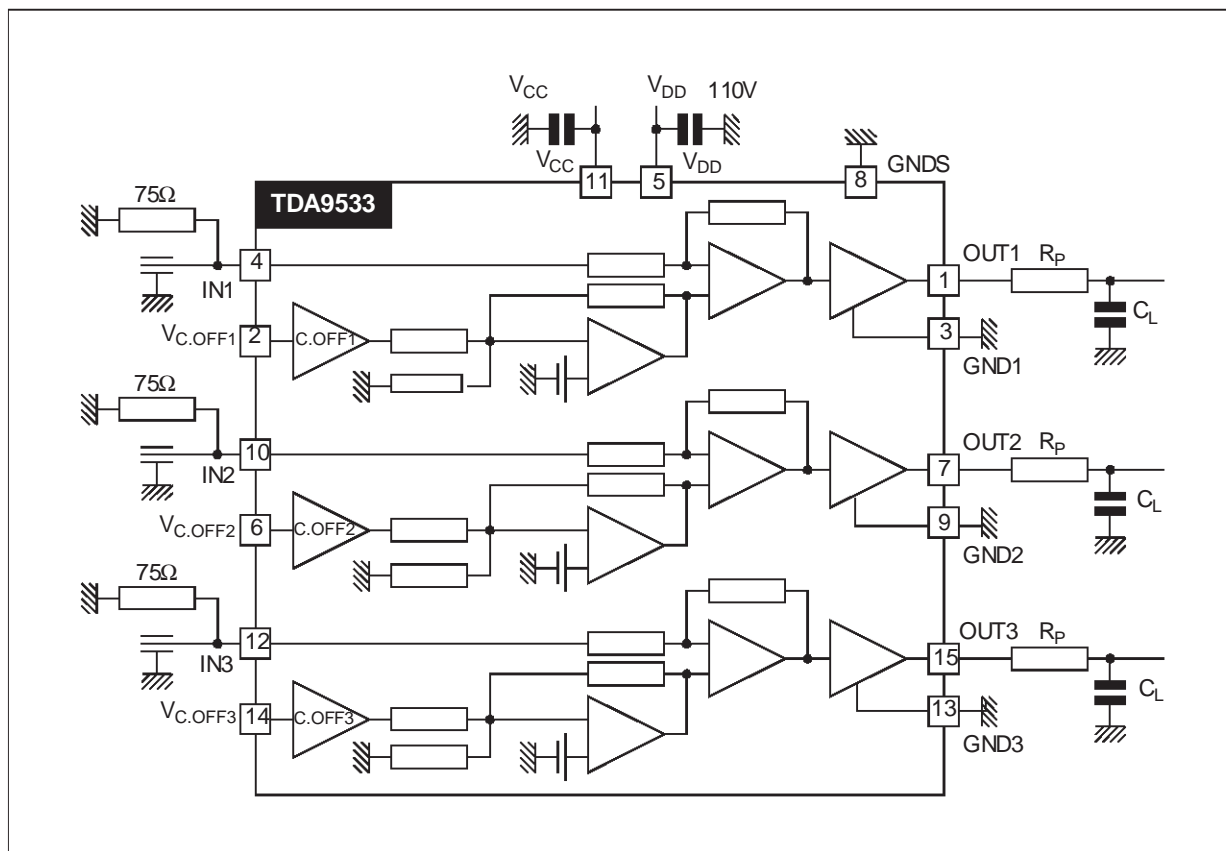

Figure 1. TDA9207/9209 - TDA9533/9530 Demonstration Board: Silk Screen and Trace (scale 1:1)

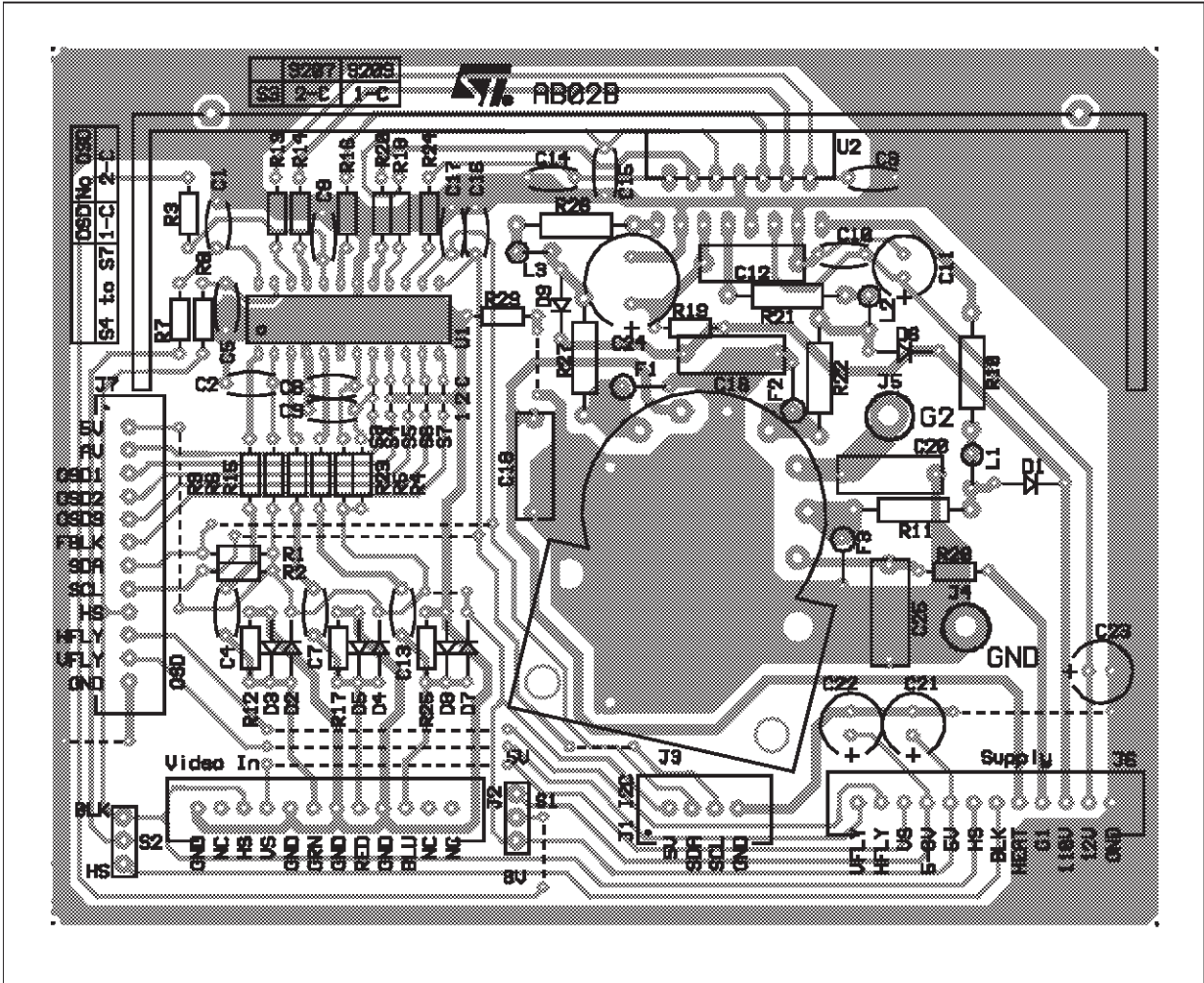
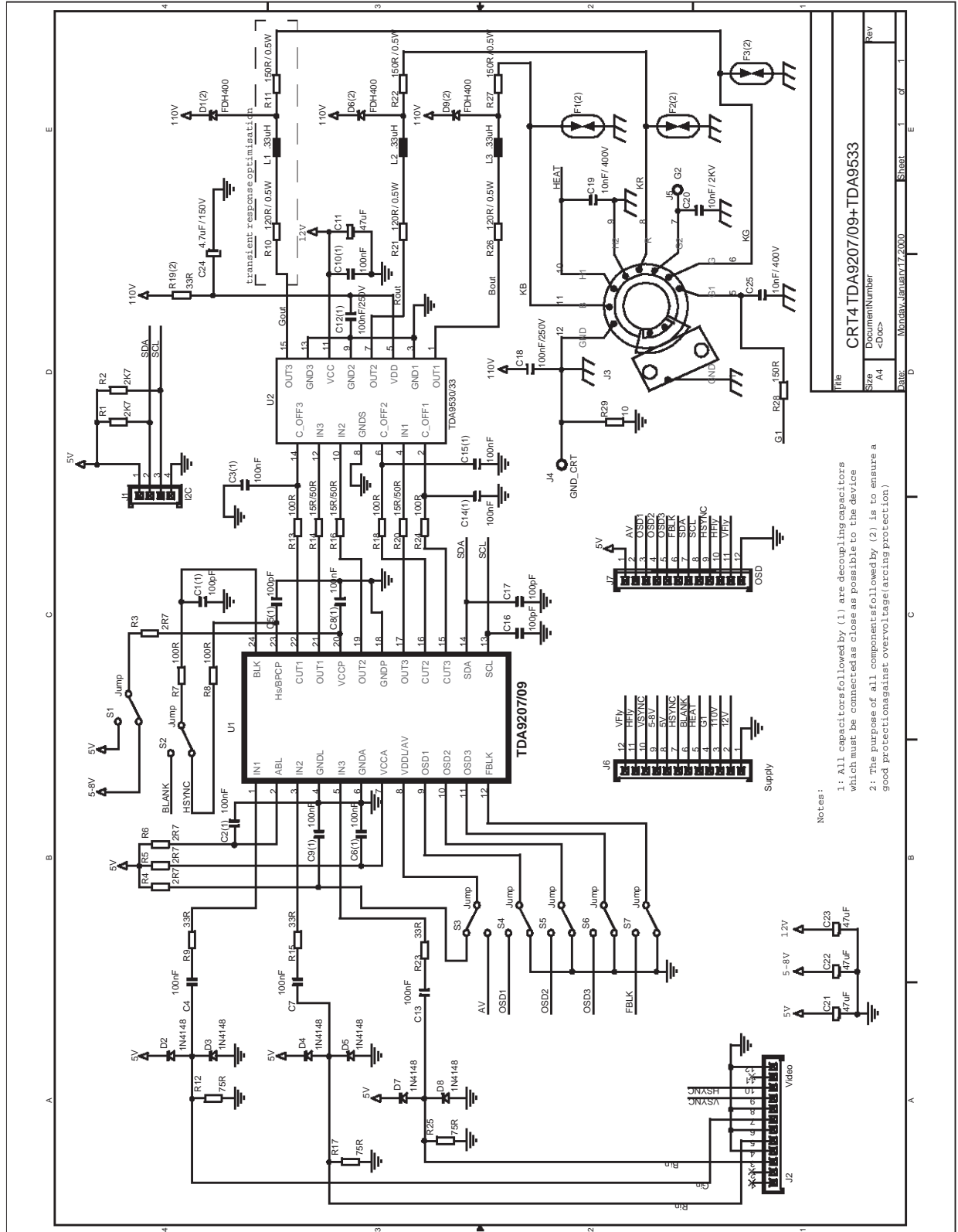

Figure 2. TDA9207/9209 - TDA9533/9530 Demonstration Board Schematic



File	CRT4 TDA9207/09+TDA9533
Size	A4
Document Number	<Doc>
Rev	
Date	Monday, January 7, 2000
Sheet	1 of 1



PACKAGE MECHANICAL DATA

15 PIN - PLASTIC MULTIWATT

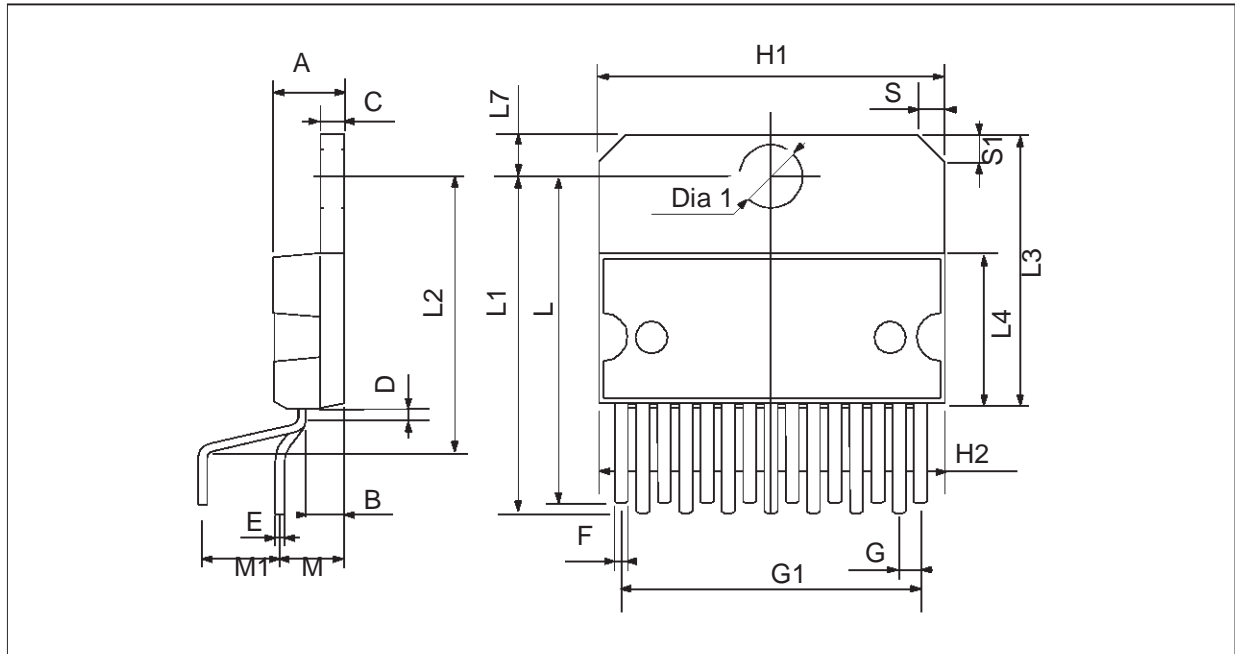

Dimensions	Millimeters			Inches		
	Min.	Typ.	Max.	Min.	Typ.	Max.
A			5			0.197
B			2.65			0.104
C			1.6			0.063
D		1			0.039	
E	0.49		0.55	0.019		0.022
F	0.66		0.75	0.026		0.030
G	1.02	1.27	1.52	0.040	0.050	0.060
G1	17.53	17.78	18.03	0.690	0.700	0.710
H1	19.6			0.772		
H2			20.2			0.795
L	21.9	22.2	22.5	0.862	0.874	0.886
L1	21.7	22.1	22.5	0.854	0.870	0.886
L2	17.65		18.1	0.695		0.713
L3	17.25	17.5	17.75	0.679	0.689	0.699
L4	10.3	10.7	10.9	0.406	0.421	0.429
L7	2.65		2.9	0.104		0.114
M	4.25	4.55	4.85	0.167	0.179	0.191
M1	4.63	5.08	5.53	0.182	0.200	0.218
S	1.9		2.6	0.075		0.102
S1	1.9		2.6	0.075		0.102
Dia. 1	3.65		3.85	0.144		0.152

Information furnished is believed to be accurate and reliable. However, STMicroelectronics assumes no responsibility for the consequences of use of such information nor for any infringement of patents or other rights of third parties which may result from its use. No license is granted by implication or otherwise under any patent or patent rights of STMicroelectronics. Specifications mentioned in this publication are subject to change without notice. This publication supersedes and replaces all information previously supplied. STMicroelectronics products are not authorized for use as critical components in life support devices or systems without express written approval of STMicroelectronics.

The ST logo is a trademark of STMicroelectronics.

© 2000 STMicroelectronics - All Rights Reserved

Purchase of I²C Components of STMicroelectronics, conveys a license under the Philips I²C Patent. Rights to use these components in a I²C system, is granted provided that the system conforms to the I²C Standard Specifications as defined by Philips.

STMicroelectronics GROUP OF COMPANIES

Australia - Brazil - China - Finland - France - Germany - Italy - Japan - Korea - Malaysia - Malta - Mexico - Morocco - The Netherlands - Singapore - Spain - Sweden - Switzerland - Taiwan - Thailand - United Kingdom - U.S.A.

<http://www.st.com>