

**INTEGRATED CIRCUITS**

# DATA SHEET



## **TDA9875A** **Digital TV Sound Processor** **(DTVSP)**

Product specification  
Supersedes data of 1998 Aug 13  
File under Integrated Circuits, IC02

1999 Dec 20

**Digital TV Sound Processor (DTVSP)****TDA9875A**

<b>CONTENTS</b>	10	<b>I<sup>2</sup>C-BUS CONTROL</b>
1	<b>FEATURES</b>	10.1 Introduction
1.1	Demodulator and decoder section	10.2 Power-up state
1.2	DSP section	10.3 Slave receiver mode
1.3	Analog audio section	10.4 Slave transmitter mode
2	<b>GENERAL DESCRIPTION</b>	10.5 Expert mode
2.1	Supported standards	11 <b>I<sup>2</sup>S-BUS DESCRIPTION</b>
3	<b>ORDERING INFORMATION</b>	12 <b>APPLICATION INFORMATION</b>
4	<b>BLOCK DIAGRAM</b>	13 <b>PACKAGE OUTLINES</b>
5	<b>PINNING</b>	14 <b>SOLDERING</b>
6	<b>FUNCTIONAL DESCRIPTION</b>	14.1 Introduction
6.1	Demodulator and decoder section	14.2 Through-hole mount packages
6.2	Digital signal processing	14.3 Surface mount packages
6.3	Analog audio section	14.4 Suitability of IC packages for wave, reflow and dipping soldering methods
7	<b>LIMITING VALUES</b>	15 <b>DEFINITIONS</b>
8	<b>THERMAL CHARACTERISTICS</b>	16 <b>LIFE SUPPORT APPLICATIONS</b>
9	<b>CHARACTERISTICS</b>	17 <b>PURCHASE OF PHILIPS I<sup>2</sup>C COMPONENTS</b>

# Digital TV Sound Processor (DTVSP)

# TDA9875A

## 1 FEATURES

### 1.1 Demodulator and decoder section

- Sound IF (SIF) input switch e.g. to select between terrestrial TV SIF and SAT SIF sources
- SIF AGC with 24 dB control range
- SIF 8-bit Analog-to-Digital Converter (ADC)
- Differential Quadrature Phase Shift Keying (DQPSK) demodulation for different standards, simultaneously with 1-channel FM demodulation
- Near Instantaneous Companded Audio Multiplex (NICAM) decoding (B/G, I and L standard)
- Two-carrier multistandard FM demodulation (B/G, D/K and M standard)
- Decoding for three analog multi-channel systems (A2, A2+ and A2\*) and satellite sound
- Optional AM demodulation for system L, simultaneously with NICAM
- Programmable identification (B/G, D/K and M standard) and different identification times.

### 1.2 DSP section

- Digital crossbar switch for all digital signal sources and destinations
- Control of volume, balance, contour, bass, treble, pseudo stereo, spatial, bass boost and soft mute
- Plop-free volume control
- Automatic Volume Level (AVL) control
- Adaptive de-emphasis for satellite
- Programmable beeper
- Monitor selection for FM/AM DC values and signals, with peak detection option
- I<sup>2</sup>S-bus interface for a feature extension (e.g. Dolby Pro Logic) with matrix, level adjust and mute.

### 1.3 Analog audio section

- Analog crossbar switch with inputs for mono and stereo (also applicable as SCART 3 input), SCART 1 input/output, SCART 2 input/output and line output
- User defined full-level/-3 dB scaling for SCART outputs
- Output selection of mono, stereo, dual A/B, dual A or dual B
- 20 kHz bandwidth for SCART-to-SCART copies
- Standby mode with function for SCART copies



- Dual audio Digital-to-Analog Converter (DAC) from DSP to analog crossbar switch, bandwidth 15 kHz
- Dual audio ADC from analog inputs to DSP
- Two dual audio DACs for loudspeaker (Main) and headphone (Auxiliary) outputs; also applicable for L, R, C and S in the Dolby Pro Logic mode with feature extension.

## 2 GENERAL DESCRIPTION

The TDA9875A is a single-chip Digital TV Sound Processor (DTVSP) for analog and digital multi-channel sound systems in TV sets and satellite receivers.

### 2.1 Supported standards

The multistandard/multi-stereo capability of the TDA9875A is mainly of interest in Europe, but also in Hong Kong/Peoples Republic of China and South East Asia. This includes B/G, D/K, I, M and L standards. In other application areas there exists only subsets of these standard combinations otherwise only single standards are transmitted.

M standard is transmitted in Europe by the American Forces Network (AFN) with European channel spacing (7 MHz VHF and 8 MHz UHF) and monaural sound.

The AM sound of L/L accent standard is normally demodulated in the first sound IF. The resulting AF signal has to be entered into the mono audio input of the TDA9875A. A second possibility is to use the internal AM demodulator stage, however this gives limited performance.

Korea has a stereo sound system similar to Europe and is supported by the TDA9875A. The differences include deviation, modulation contents and identification. It is based on M standard.

An overview of the supported standards and sound systems and their key parameters is given in Table 1.

The analog multi-channel sound systems (A2, A2+ and A2\*) are 2-Carrier Systems (2CS).

## Digital TV Sound Processor (DTVSP)

## TDA9875A

## 2.1.1 ANALOG 2-CARRIER SYSTEMS

**Table 1** Frequency modulation

STANDARD	SOUND SYSTEM	CARRIER FREQUENCY (MHz)	FM DEVIATION (kHz)			MODULATION		BANDWIDTH/ DE-EMPHASIS (kHz/ $\mu$ s)
			NOM.	MAX.	OVER	SC1	SC2	
M	mono	4.5	15	25	50	mono	–	15/75
M	A2+	4.5/4.724	15	25	50	$\frac{1}{2}(L + R)$	$\frac{1}{2}(L - R)$	15/75 (Korea)
B/G	A2	5.5/5.742	27	50	80	$\frac{1}{2}(L + R)$	R	15/50
I	mono	6.0	27	50	80	mono	–	15/50
D/K	A2	6.5/6.742	27	50	80	$\frac{1}{2}(L + R)$	R	15/50
D/K	A2*	6.5/6.258	27	50	80	$\frac{1}{2}(L + R)$	R	15/50

**Table 2** Identification for A2 systems

PARAMETER	A2/A2*	A2+ (KOREA)
Pilot frequency	54.6875 kHz = $3.5 \times$ line frequency	55.0699 kHz = $3.5 \times$ line frequency
Stereo identification frequency	117.5 Hz = $\frac{\text{line frequency}}{133}$	149.9 Hz = $\frac{\text{line frequency}}{105}$
Dual identification frequency	274.1 Hz = $\frac{\text{line frequency}}{57}$	276.0 Hz = $\frac{\text{line frequency}}{57}$
AM modulation depth	50%	50%

## 2.1.2 2-CARRIER SYSTEMS WITH NICAM

**Table 3** NICAM

STANDARD	SC1						SC2 NICAM (MHz)	DE-EMPHASIS	ROLL-OFF (%)	NICAM CODING
	FREQUENCY (MHz)	TYPE	MODULATION							
			INDEX (%)		DEVIATION (kHz)					
			NOM.	MAX.	NOM.	MAX.				
B/G	5.5	FM	–	–	27	50	5.85	J17	40	note 1
I	6.0	FM	–	–	27	50	6.552	J17	100	note 1
D/K	6.5	FM	–	–	27	50	5.85	J17	40	note 2
L	6.5	AM	54	100	–	–	5.85	J17	40	note 1

**Notes**

1. See "EBU specification" or equivalent specification.
2. Not yet defined.

## Digital TV Sound Processor (DTVSP)

## TDA9875A

## 2.1.3 SATELLITE SYSTEMS

An important specification for satellite TV reception is the 'Astra specification'. The TDA9875A is suited for the reception of Astra and other satellite signals.

**Table 4** FM satellite sound

CARRIER TYPE	CARRIER FREQUENCY (MHz)	MODULATION INDEX	MAXIMUM FM DEVIATION (kHz)	MODULATION	BANDWIDTH/ DE-EMPHASIS (kHz/ $\mu$ s)
Main	6.50 <sup>(1)</sup>	0.26	85	mono	15/50 <sup>(2)</sup>
Sub	7.02/7.20	0.15	50	m/st/d <sup>(3)</sup>	15/adaptive <sup>(4)</sup>
Sub	7.38/7.56				
Sub	7.74/7.92				
Sub	8.10/8.28				

**Notes**

1. For other satellite systems, frequencies of e.g. 5.80, 6.60 or 6.65 MHz can also be received.
2. A de-emphasis of 60  $\mu$ s, or in accordance with J17, is available.
3. m/st/d = mono, stereo or dual language sound.
4. Adaptive de-emphasis is compatible to transmitter specification.

**3 ORDERING INFORMATION**

TYPE NUMBER	PACKAGE		
	NAME	DESCRIPTION	VERSION
TDA9875A	SDIP64	plastic shrink dual in-line package; 64 leads (750 mil)	SOT274-1
TDA9875AH	QFP64	plastic quad flat package; 64 leads (lead length 1.6 mm); body 14 × 14 × 2.7 mm	SOT393-1

# Digital TV Sound Processor (DTVSP)

# TDA9875A

## 4 BLOCK DIAGRAM

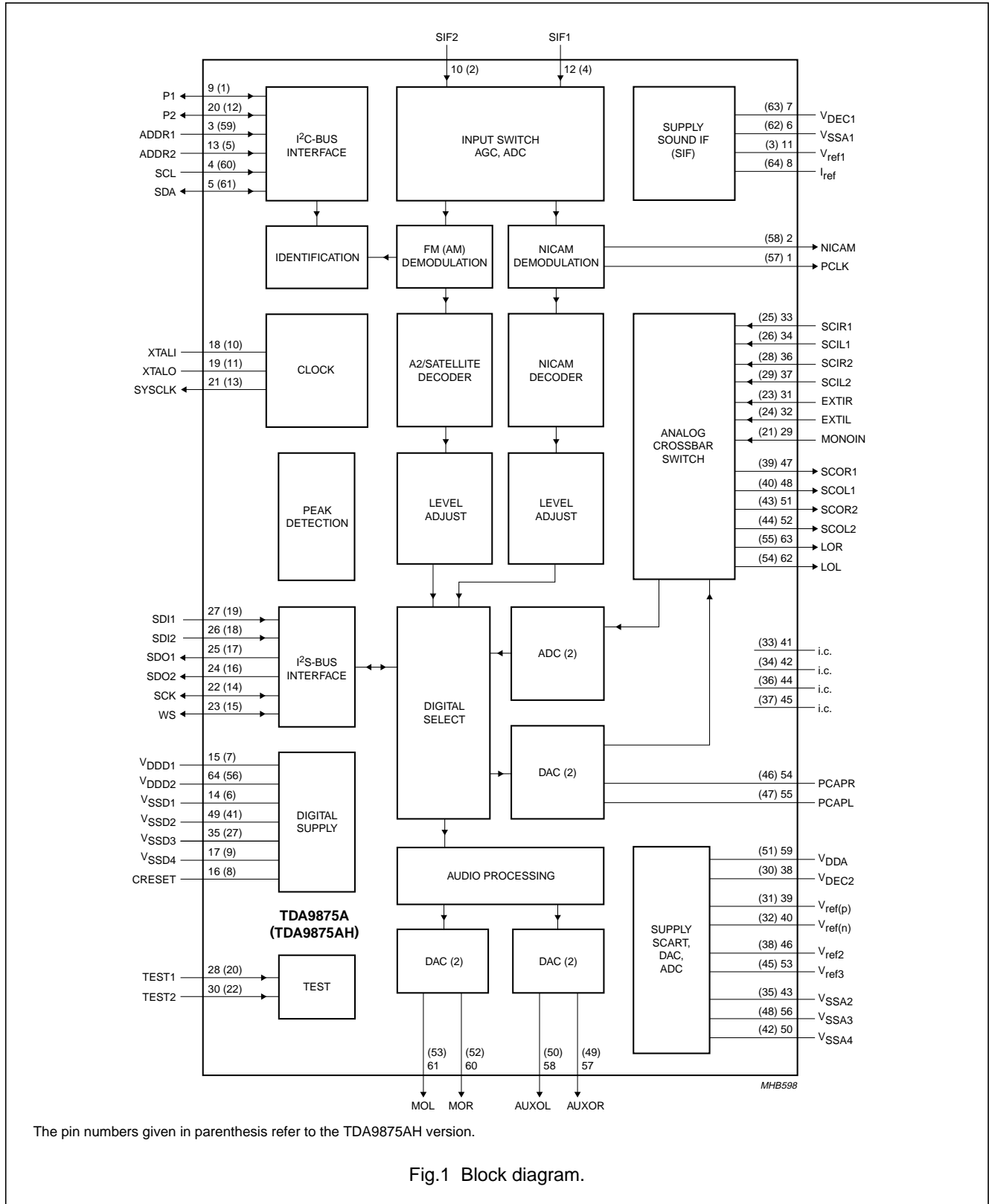

Fig.1 Block diagram.

## Digital TV Sound Processor (DTVSP)

## TDA9875A

## 5 PINNING

SYMBOL	PIN		PIN TYPE <sup>(1)</sup>	DESCRIPTION
	TDA9875A	TDA9875AH		
PCLK	1	57	O	NICAM clock output at 728 kHz
NICAM	2	58	O	serial NICAM data output at 728 kHz
ADDR1	3	59	I	I <sup>2</sup> C-bus slave address input 1
SCL	4	60	I	I <sup>2</sup> C-bus clock input
SDA	5	61	I/O	I <sup>2</sup> C-bus data input/output
V <sub>SSA1</sub>	6	62	S	supply ground 1; analog front-end circuitry
V <sub>DEC1</sub>	7	63	–	supply voltage decoupling 1; analog front-end circuitry
I <sub>ref</sub>	8	64	–	resistor for reference current generator; analog front-end circuitry
P1	9	1	I/O	general purpose input/output pin 1
SIF2	10	2	I	sound IF input 2
V <sub>ref1</sub>	11	3	–	reference voltage 1; analog front-end circuitry
SIF1	12	4	I	sound IF input 1
ADDR2	13	5	I	I <sup>2</sup> C-bus slave address input 2
V <sub>SSD1</sub>	14	6	S	supply ground 1; digital circuitry
V <sub>DD1</sub>	15	7	S	digital supply voltage 1; digital circuitry
CRESET	16	8	–	capacitor for Power-on reset
V <sub>SSD4</sub>	17	9	S	supply ground 4; digital circuitry
XTALI	18	10	I	crystal oscillator input
XTALO	19	11	O	crystal oscillator output
P2	20	12	I/O	general purpose input/output pin 2
SYSCLK	21	13	O	system clock output
SCK	22	14	I/O	I <sup>2</sup> S-bus clock input/output
WS	23	15	I/O	I <sup>2</sup> S-bus word select input/output
SDO2	24	16	O	I <sup>2</sup> S-bus data output 2 (I <sup>2</sup> S2 output)
SDO1	25	17	O	I <sup>2</sup> S-bus data output 1 (I <sup>2</sup> S1 output)
SDI2	26	18	I	I <sup>2</sup> S-bus data input 2 (I <sup>2</sup> S2 input)
SDI1	27	19	I	I <sup>2</sup> S-bus data input 1 (I <sup>2</sup> S1 input)
TEST1	28	20	I	test pin 1; connected to V <sub>SSD1</sub> for normal operating mode
MONOIN	29	21	I	audio mono input
TEST2	30	22	I	test pin 2; connected to V <sub>SSD1</sub> for normal operating mode
EXTIR	31	23	I	external audio input right channel
EXTIL	32	24	I	external audio input left channel
SCIR1	33	25	I	SCART 1 input right channel
SCIL1	34	26	I	SCART 1 input left channel
V <sub>SSD3</sub>	35	27	S	supply ground 3; digital circuitry
SCIR2	36	28	I	SCART 2 input right channel
SCIL2	37	29	I	SCART 2 input left channel
V <sub>DEC2</sub>	38	30	–	supply voltage decoupling 2; audio analog-to-digital converter circuitry

## Digital TV Sound Processor (DTVSP)

## TDA9875A

SYMBOL	PIN		PIN TYPE <sup>(1)</sup>	DESCRIPTION
	TDA9875A	TDA9875AH		
V <sub>ref(p)</sub>	39	31	–	positive reference voltage; audio analog-to-digital converter circuitry
V <sub>ref(n)</sub>	40	32	–	reference voltage ground; audio analog-to-digital converter circuitry
i.c.	41	33	–	internally connected; note 2
i.c.	42	34	–	internally connected; note 3
V <sub>SSA2</sub>	43	35	S	supply ground 2; audio analog-to-digital converter circuitry
i.c.	44	36	–	internally connected; note 3
i.c.	45	37	–	internally connected; note 2
V <sub>ref2</sub>	46	38	–	reference voltage 2; audio analog-to-digital converter circuitry
SCOR1	47	39	O	SCART 1 output right channel
SCOL1	48	40	O	SCART 1 output left channel
V <sub>SSD2</sub>	49	41	S	supply ground 2; digital circuitry
V <sub>SSA4</sub>	50	42	S	supply ground 4; audio operational amplifier circuitry
SCOR2	51	43	O	SCART 2 output right channel
SCOL2	52	44	O	SCART 2 output left channel
V <sub>ref3</sub>	53	45	–	reference voltage 3; audio digital-to-analog converter and operational amplifier circuitry
PCAPR	54	46	–	post-filter capacitor pin right channel; audio digital-to-analog converter
PCAPL	55	47	–	post-filter capacitor pin left channel; audio digital-to-analog converter
V <sub>SSA3</sub>	56	48	S	supply ground 3; audio digital-to-analog converter circuitry
AUXOR	57	49	O	headphone (Auxiliary) output right channel
AUXOL	58	50	O	headphone (Auxiliary) output left channel
V <sub>DDA</sub>	59	51	S	analog supply voltage; analog circuitry
MOR	60	52	O	loudspeaker (Main) output right channel
MOL	61	53	O	loudspeaker (Main) output left channel
LOL	62	54	O	line output left channel
LOR	63	55	O	line output right channel
V <sub>DDD2</sub>	64	56	S	digital supply voltage 2; digital circuitry

**Notes**

1. Pin type: I = input, O = output, S = supply.
2. Test pin: CMOS level input; pull-up resistor; can be connected to V<sub>SS</sub>.
3. Test pin: CMOS 3-state stage; can be connected to V<sub>SS</sub>.



Digital TV Sound Processor (DTVSP)

TDA9875A

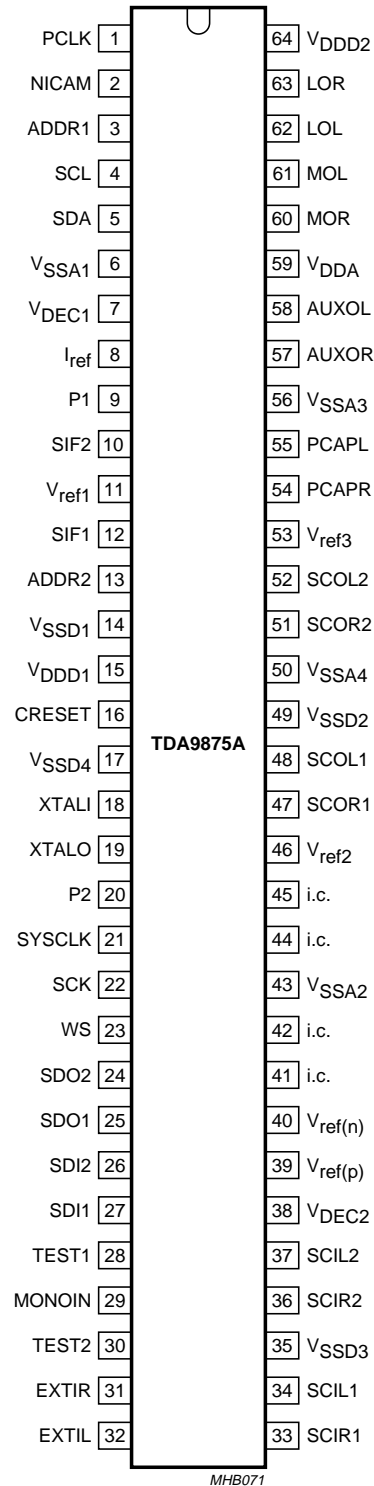

Fig.2 Pin configuration (TDA9875A).

Digital TV Sound Processor (DTVSP)

TDA9875A

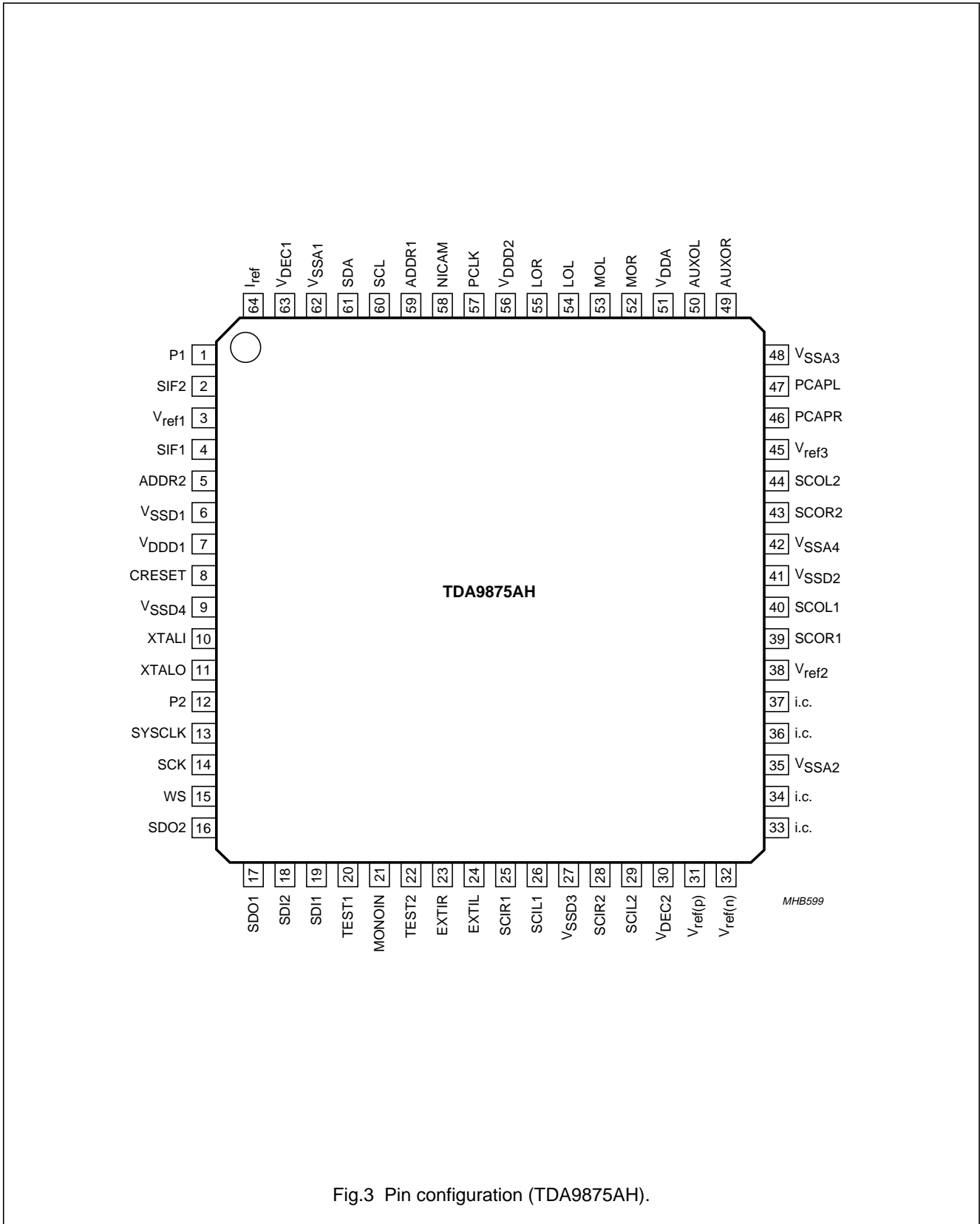

Fig.3 Pin configuration (TDA9875AH).

## Digital TV Sound Processor (DTVSP)

TDA9875A

### 6 FUNCTIONAL DESCRIPTION

#### 6.1 Demodulator and decoder section

##### 6.1.1 SIF INPUT

Two input pins are provided: SIF1 e.g. for terrestrial TV and SIF2 e.g. for a satellite tuner. For higher SIF signal levels the SIF input can be attenuated with an internal switchable –10 dB resistor divider. As no specific filters are integrated, both inputs have the same specification giving flexibility in application. The selected signal is passed through an AGC circuit and then digitized by an 8-bit ADC operating at 24.576 MHz.

##### 6.1.2 AGC

The gain of the AGC amplifier is controlled from the ADC output by means of a digital control loop employing hysteresis. The AGC has a fast attack behaviour to prevent ADC overloads and a slow decay behaviour to prevent AGC oscillations. For AM demodulation the AGC must be switched off. When switched off, the control loop is reset and fixed gain settings can be chosen (see Table 15).

The AGC can be controlled via the I<sup>2</sup>C-bus. Details can be found in the I<sup>2</sup>C-bus register definitions (see Chapter 10).

##### 6.1.3 MIXER

The digitized input signal is fed to the mixers, which mix one or both input sound carriers down to zero IF. A 24-bit control word for each carrier sets the required frequency. Access to the mixer control word registers is via the I<sup>2</sup>C-bus. When receiving NICAM programs, a feedback signal is added to the control word of the second carrier mixer to establish a carrier-frequency loop.

##### 6.1.4 FM AND AM DEMODULATION

An FM or AM input signal is fed via a band-limiting filter to a demodulator that can be used for either FM or AM demodulation. Apart from the standard (fixed) de-emphasis characteristic, an adaptive de-emphasis is available for encoded satellite programs. A stereo decoder recovers the left and right signal channels from the demodulated sound carriers. Both the European and Korean stereo systems are supported.

##### 6.1.5 FM IDENTIFICATION

The identification of the FM sound mode is performed by AM synchronous demodulation of the pilot signal and narrow-band detection of the identification frequencies. The result is available via the I<sup>2</sup>C-bus interface. A selection can be made via the I<sup>2</sup>C-bus for B/G, D/K and M standard and for three different modes that represent different trade-offs between speed and reliability of identification.

##### 6.1.6 NICAM DEMODULATION

The NICAM signal is transmitted in a DQPSK code at a bit rate of 728 kbit/s. The NICAM demodulator performs DQPSK demodulation and feeds the resulting bitstream and clock signal onto the NICAM decoder and, for evaluation purposes, to pins PCLK and NICAM.

A timing loop controls the frequency of the crystal oscillator to lock the sampling rate to the symbol timing of the NICAM data.

##### 6.1.7 NICAM DECODER

The device performs all decoding functions in accordance with the “*EBU NICAM 728 specification*”. After locking to the frame alignment word, the data is descrambled by applying the defined pseudo-random binary sequence and the device will then synchronize to the periodic frame flag bit C0.

Bit VDSP (see Section 10.4.1) indicates that the decoder has locked to the NICAM data and that the data is valid sound data.

The status of the NICAM decoder can be read out from the NICAM status register by the user (see Section 10.4.2). Bit OSB indicates that the decoder has locked to the NICAM data. Bit C4 indicates that the sound conveyed by the FM mono channel is identical to the sound signal conveyed by the NICAM channel.

The error byte contains the number of sound sample errors, resulting from parity checking, that occurred in the past 128 ms period. The Bit Error Rate (BER) can be calculated using the following equation:

$$\text{BER} = \frac{\text{bit errors}}{\text{total bits}} \approx \text{error byte} \times 1.74 \times 10^{-5}$$

## Digital TV Sound Processor (DTVSP)

## TDA9875A

### 6.1.8 NICAM AUTO-MUTE

This function is enabled by setting bit AMUTE to logic 0 (see Section 10.3.11).

Upper and lower error limits may be defined by writing appropriate values to two registers in the I<sup>2</sup>C-bus section (see Sections 10.3.13 and 10.3.14). When the number of errors in a 128 ms period exceeds the upper error limit the auto-mute function will switch the output sound from NICAM to whatever sound is on the first sound carrier (FM or AM). When the error count is smaller than the lower error limit the NICAM sound is restored.

The auto-mute function can be disabled by setting bit AMUTE to logic 1. In this condition clicks become audible when the error count increases; the user will hear a signal of degrading quality.

A decision to enable/disable the auto-muting is taken by the microcontroller based on an interpretation of the application control bits C1, C2, C3 and C4 and, possibly, any additional strategy implemented by the set maker in the microcontroller software.

For NICAM L applications, it is recommended to demodulate AM sound in the first sound IF and connect the audio signal to the mono input of the TDA9875A. By setting bit AMSEL (see Section 10.3.11), the auto-mute function will switch to the audio ADC instead of switching to the first sound carrier. The ADC source selector (see Section 10.3.20) should be set to mono input, where the AM sound signal should be connected.

### 6.1.9 CRYSTAL OSCILLATOR

The circuitry of the crystal oscillator is fully integrated, only the external 24.576 MHz crystal is needed (see Fig.10).

### 6.1.10 TEST PINS

Test pins TEST1 and TEST2 are active HIGH and in the normal operating mode of the device they are connected to V<sub>SSD1</sub>. Test functions are for manufacturing tests only and are not available to customers. Without external circuitry these pins are pulled down to a LOW level with internal resistors.

### 6.1.11 POWER FAIL DETECTOR

The power fail detector monitors the internal power supply for the digital part of the device. If the supply has temporarily been lower than the specified lower limit, the Power-on reset bit POR (see Section 10.4.1), will be set to logic 1.

Bit CLRPOP (see Section 10.3.2) resets the Power-on reset flip-flop to LOW. If this is detected, an initialization of the TDA9875A has to be carried out to ensure reliable operation.

### 6.1.12 POWER-ON RESET

The reset is active LOW. In order to perform a reset at power-up, a simple RC circuit may be used which consists of the integrated passive pull-up resistor and an external capacitor connected to ground. The pull-up resistor has a nominal value of 50 k $\Omega$ , which can easily be measured between pins CRESET and V<sub>DDD2</sub>. Before the supply voltage has reached a certain minimum, the state of the circuit is completely undefined, and it remains in this undefined state unless a reset is applied.

The reset is guaranteed to be active when:

- The power supply is within the specified limits (4.75 and 5.5 V)
- The crystal oscillator is functioning
- The voltage at pin CRESET is below 0.3V<sub>DDD</sub> (1.5 V if V<sub>DDD</sub> = 5.0 V, typically below 1.8 V).

The required capacitor value depends on the gradient of the rising power supply voltage. The time constant of the RC circuit should be clearly larger than the rise time of the power supply, to make sure that the reset condition is always satisfied (see Fig.4), even considering the tolerance spread. To avoid problems with a too slow discharging of the capacitor at power-down, it may be helpful to add a diode from pin CRESET to V<sub>DDD</sub>. It should be noted that the internal ESD protection diode does not help here as it only conducts at higher voltages. Under difficult power supply conditions (e.g. very slow or non-monotonic ramp-up), it is recommended to drive the reset line from a microcontroller port or the like.

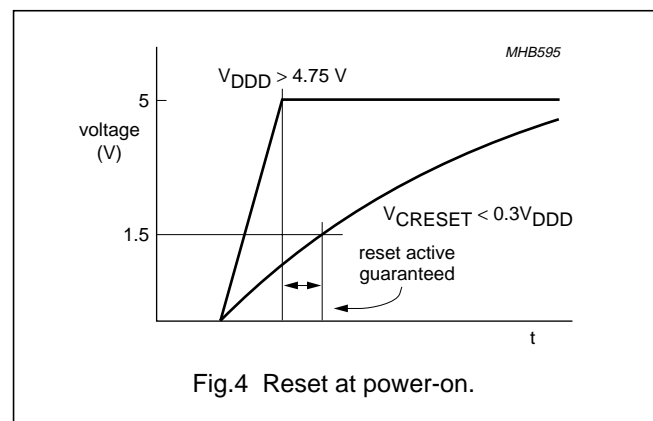

Fig.4 Reset at power-on.

# Digital TV Sound Processor (DTVSP)

# TDA9875A

## 6.2 Digital signal processing

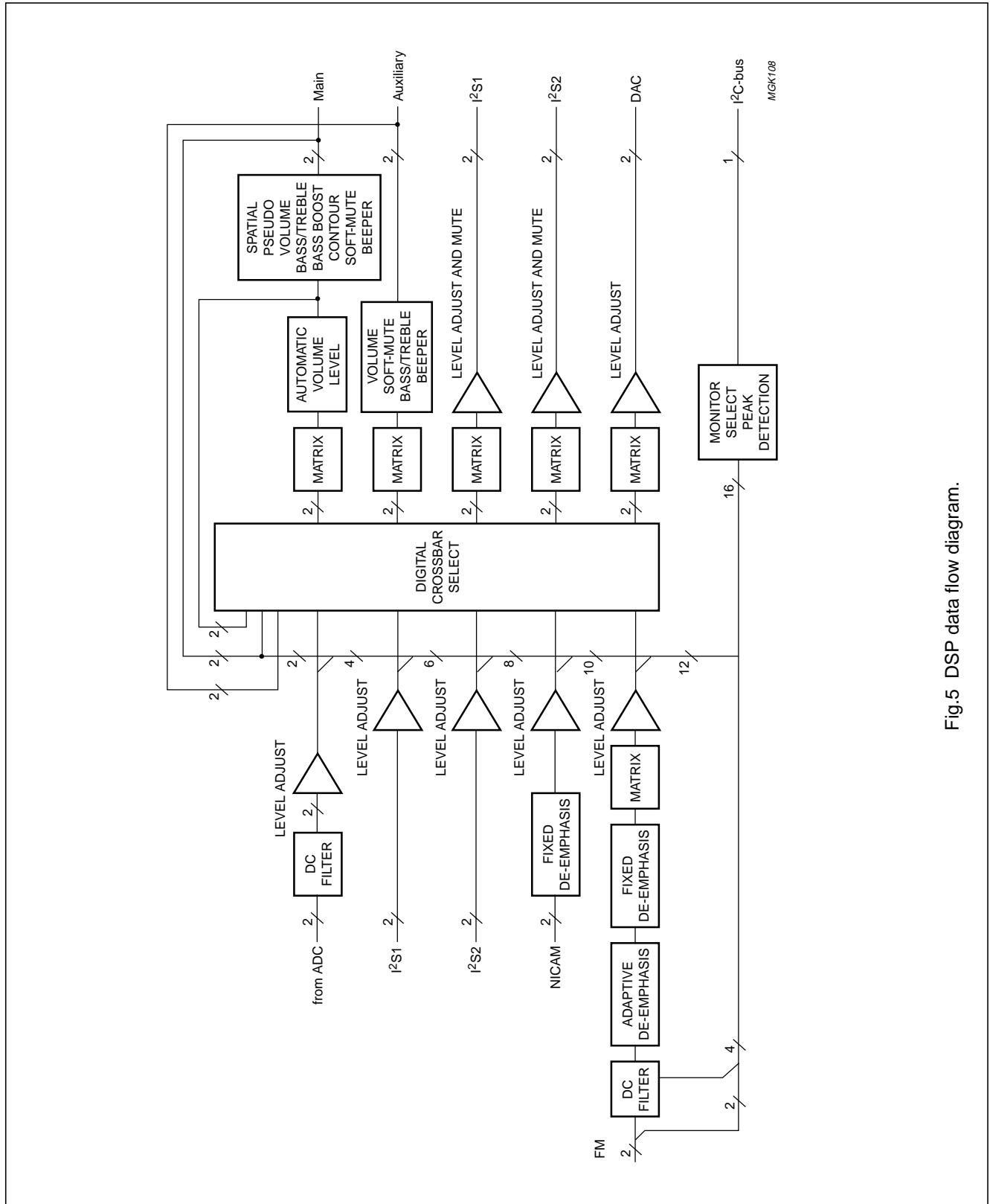

Fig.5 DSP data flow diagram.

## Digital TV Sound Processor (DTVSP)

## TDA9875A

### 6.2.1 LEVEL SCALING

All input channels to the digital crossbar switch (except for the loudspeaker feedback path) are equipped with a level adjust facility to change the signal level in a range from +15 to -15 dB (see Fig.5). It is recommended to scale all input channels to be 15 dB below full-scale (-15 dB full-scale) under nominal conditions.

### 6.2.2 NICAM PATH

The NICAM path has a switchable J17 de-emphasis.

### 6.2.3 FM (AM) PATH

A high-pass filter suppresses DC offsets from the FM demodulator due to carrier frequency offsets and supplies the monitor/peak function with DC values and an unfiltered signal, e.g. for the purpose of carrier detection.

The de-emphasis function offers fixed settings for the supported standards (50, 60 or 75  $\mu$ s and J17).

An adaptive de-emphasis is available for Wegener-Panda 1 encoded programs.

A matrix performs the dematrixing of the A2 stereo, dual and mono signals.

### 6.2.4 NICAM AUTO-MUTE

If NICAM B/G, I or D/K is received, the auto-mute is enabled and the signal quality becomes poor, the digital crossbar switch switches automatically to FM and switches the matrix to channel 1. The automatic switching depends on the NICAM bit error rate.

The auto-mute function can be disabled via the I<sup>2</sup>C-bus.

For NICAM L applications, it is recommended to demodulate AM sound in the first sound IF and connect the audio signal to the mono input of the TDA9875A.

By setting bit AMSEL (see Section 10.3.11), the auto-mute function will switch to the audio ADC instead of switching to the first sound carrier. The ADC source selector bits (see Section 10.3.20) should be set to mono input, where the AM sound signal should be connected.

### 6.2.5 MONITOR

This function provides data words from a number of locations in the signal processing paths to the I<sup>2</sup>C-bus interface (2 data bytes). Signal sources include the FM demodulator outputs, most inputs to the digital crossbar switch and the outputs of the ADC. Source selection and data read-out is performed via the I<sup>2</sup>C-bus.

Optionally, the peak value can be measured instead of simply taking samples. The internally stored peak value is reset to zero when the data is read via the I<sup>2</sup>C-bus.

The monitor function may be used, for example, for signal level measurements or carrier detection.

### 6.2.6 LOUDSPEAKER (MAIN) CHANNEL

The matrix provides the following functions: forced mono, stereo, channel swap, channel 1, channel 2 and spatial effects.

There are fixed coefficient sets for spatial settings of 30%, 40% and 52%.

The Automatic Volume Level (AVL) function provides a constant output level of -23 dB (full-scale) for input levels between 0 and -29 dB (full-scale). There are some fixed decay time constants to choose from, i.e. 2, 4 and 8 s.

Pseudo stereo is based on a phase shift in one channel via a second-order all-pass filter. There are fixed coefficient sets to provide 90 degrees phase shift at frequencies of 150, 200 and 300 Hz.

Volume is controlled individually for each channel ranging from +24 to -83 dB with 1 dB resolution. There is also a mute position. For the purpose of a simple control software in the microcontroller, the decimal number that is sent as an I<sup>2</sup>C-bus data byte for volume control is identical to the volume setting in dB (e.g. the I<sup>2</sup>C-bus data byte +10 sets the new volume value to +10 dB).

Balance can be realized by independent control of the left and right channel volume settings.

Contour is adjustable between 0 and +18 dB with 1 dB resolution. This function is linked to the volume setting by means of microcontroller software.

Bass is adjustable between +15 and -12 dB with 1 dB resolution and treble is adjustable between +12 and -12 dB with 1 dB resolution.

For the purpose of a simple control software in the microcontroller, the decimal number that is sent as an I<sup>2</sup>C-bus data byte for contour, bass or treble is identical to the new contour, bass or treble setting in dB (e.g. the I<sup>2</sup>C-bus data byte +8 sets the new value to +8 dB).

Extra bass boost is provided up to 20 dB with 2 dB resolution. The implemented coefficient set serves merely as an example on how to use this filter.

The beeper provides tones in a range from approximately 400 Hz to 30 kHz. The frequency can be selected via the I<sup>2</sup>C-bus. The beeper output signal is added to the loudspeaker and headphone channel signals.

## Digital TV Sound Processor (DTVSP)

## TDA9875A

The beeper volume is adjustable with respect to full-scale between 0 and -93 dB with 3 dB resolution. The beeper is not effected by mute.

Soft mute provides a mute ability in addition to volume control with a well defined time (32 ms) after which the soft mute is completed. A smooth fading is achieved by a cosine masking.

### 6.2.7 HEADPHONE (AUXILIARY) CHANNEL

The matrix provides the following functions: forced mono, stereo, channel swap, channel 1 and channel 2 (or C and S in Dolby Surround Pro Logic mode).

Volume is controlled individually for each channel in a range from +24 to -83 dB with 1 dB resolution. There is also a mute position. For the purpose of a simple control software in the microcontroller, the decimal number that is sent as an I<sup>2</sup>C-bus data byte for volume control is identical to the volume setting in dB (e.g. the I<sup>2</sup>C-bus data byte +10 sets the new volume value to +10 dB).

Balance can be realized by independent control of the left and right channel volume settings.

Bass is adjustable between +15 and -12 dB with 1 dB resolution and treble is adjustable between +12 and -12 dB with 1 dB resolution. For the purpose of a simple control software in the microcontroller, the decimal number that is sent as an I<sup>2</sup>C-bus data byte for bass or treble is identical to the new bass or treble setting in dB (e.g. the I<sup>2</sup>C-bus data byte +8 sets the new value to +8 dB).

The beeper provides tones in a range from approximately 400 Hz to 30 kHz. The frequency can be selected via the I<sup>2</sup>C-bus. The beeper output signal is added to the loudspeaker and headphone channel signals. The beeper volume is adjustable with respect to full-scale between 0 and -93 dB with 3 dB resolution. The beeper is not effected by mute.

Soft mute provides a mute ability in addition to volume control with a well defined time (32 ms) after which the soft mute is completed. A smooth fading is achieved by a cosine masking.

### 6.2.8 FEATURE INTERFACE

The feature interface comprises two I<sup>2</sup>S-bus input/output ports and a system clock output. Each I<sup>2</sup>S-bus port is equipped with level adjust facilities that can change the signal level in a range from +15 to -15 dB with 1 dB resolution. Outputs can be disabled to improve EMC performance.

The I<sup>2</sup>S-bus output matrix provides the following functions: forced mono, stereo, channel swap, channel 1 and channel 2.

One example of how the feature interface can be used in a TV set is to connect an external Dolby Surround Pro Logic DSP, such as the SAA7710, to the I<sup>2</sup>S-bus ports. Outputs must be enabled and a suitable master clock signal for the DSP can be taken from pin SYSCLK. A stereo signal from any source will be output on one of the I<sup>2</sup>S-bus serial data outputs and the four processed signal channels will be entered at both I<sup>2</sup>S-bus serial data inputs. Left and right could then be output to the power amplifiers via the Main channel, centre and surround via the Auxiliary channel.

### 6.2.9 CHANNEL FROM THE AUDIO ADC

The signal level at the output of the ADC can be adjusted in a range from +15 to -15 dB with 1 dB resolution. The audio ADC itself is scaled to a gain of -6 dB.

### 6.2.10 CHANNEL TO THE ANALOG CROSSBAR PATH

Level adjust with control positions 0, +3, +6 and +9 dB.

### 6.2.11 DIGITAL CROSSBAR SWITCH

Input channels to the crossbar switch are from the audio ADC, I<sup>2</sup>S1, I<sup>2</sup>S2, FM path, NICAM path and from the loudspeaker channel path after matrix and AVL (see Fig.8).

Output channels comprise loudspeaker, headphone, I<sup>2</sup>S1, I<sup>2</sup>S2 and audio DACs for line output and SCART. I<sup>2</sup>S1 and I<sup>2</sup>S2 outputs also provide digital outputs from the loudspeaker and headphone channels, but without the beeper signals.

### 6.2.12 SIGNAL GAIN

There are a number of functions that can provide signal gain, e.g. volume, bass and treble control. Great care has to be taken when using gain with large input signals in order not to exceed the maximum possible signal swing, which would cause severe signal distortion. The nominal signal level of the various signal sources to the digital crossbar switch should be 15 dB below digital full-scale (-15 dB full-scale). This means that a volume setting of, say, +15 dB would just produce a full-scale output signal and not cause clipping, if the signal level is nominal.

Sending illegal data patterns via the I<sup>2</sup>C-bus will not cause any changes of the current setting for the volume, bass, treble, bass boost and level adjust functions.

## Digital TV Sound Processor (DTVSP)

## TDA9875A

## 6.2.13 EXPERT MODE

The TDA9875A provides a special expert mode that gives direct write access to the internal Coefficient RAM (CRAM) of the DSP. It can be used to create user-defined characteristics, such as a tone control with different corner frequencies or special boost/cut characteristics to correct the low-frequency loudspeaker and/or cabinet frequency responses by means of the bass boost filter. However, this mode must be used with great care.

More information on the functions of this device, such as the number of coefficients per function, their default values, memory addresses, etc., can be made available on request.

## 6.2.14 DSP FUNCTIONS

**Table 5** Overview of DSP functions

FUNCTION	EXPERT MODE	PARAMETER	VALUE	UNIT
Bass control for loudspeaker and headphone output	yes	control range	-12 to +15	dB
		resolution	1	dB
		resolution at frequency	40	Hz
Treble control for loudspeaker and headphone output	yes	control range	-12 to +12	dB
		resolution	1	dB
		resolution at frequency	14	kHz
Contour for loudspeaker output	yes	control range	0 to +18	dB
		resolution	1	dB
		resolution at frequency	40	Hz
Bass boost for loudspeaker output	yes	control range	0 to +20	dB
		resolution	2	dB
		resolution at frequency	20	Hz
		corner frequency	350	Hz
Volume control for each separate channel in loudspeaker and headphone output	no	control range	-83 to +24	dB
		resolution	1	dB
		mute position at step	1010 1100	
Soft mute for loudspeaker and headphone output	no	processing time	32	ms
Spatial effects	yes	anti-phase crosstalk positions	30, 40 and 52	%
Pseudo stereo	yes	90 degrees phase shift at frequency	150, 200 and 300	Hz
Beeper additional to the signal in the loudspeaker and headphone channel	yes	beep frequencies	see Section 10.3.38	
		control range	0 to -93	dB
		resolution	3	dB
		mute position at step	0010 0000	
Automatic Volume Level (AVL)	yes	step width	quasi continuously	
		AVL output level for an input level between 0 and -29 dB (full-scale)	-23	dB
		attack time	10	ms
		decay time constant	2, 4 and 8	s



Digital TV Sound Processor (DTVSP)

TDA9875A

FUNCTION	EXPERT MODE	PARAMETER	VALUE	UNIT
General	no	-3 dB lower corner frequency of DSP	10	Hz
		-1 dB bandwidth of DSP	14.5	kHz
Level adjust I <sup>2</sup> S1 and I <sup>2</sup> S2 inputs	yes	control range	-15 to +15	dB
		resolution	1	dB
Level adjust I <sup>2</sup> S1 and I <sup>2</sup> S2 outputs	yes	control range	-15 to +15	dB
		resolution	1	dB
		mute position at step	0001 0000	
Level adjust analog crossbar path	no	control positions	0, 3, 6 and 9	dB
Level adjust audio ADC outputs	yes	control range	+15 to -15	dB
		resolution	1	dB
Level adjust NICAM path	yes	control range	+15 to -15	dB
		resolution	1	dB
Level adjust FM path	yes	control range	+15 to -15	dB
		resolution	1	dB

6.3 Analog audio section

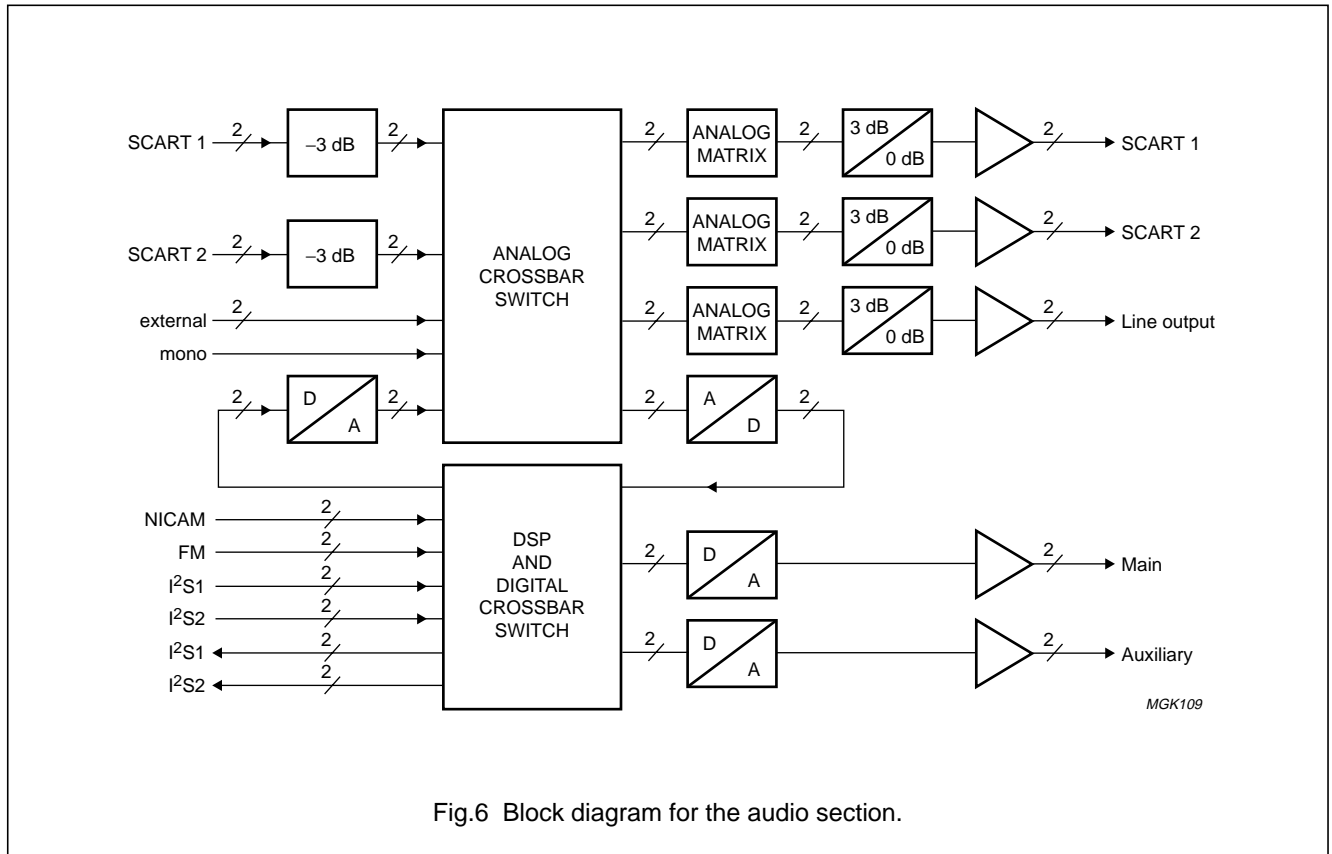

Fig.6 Block diagram for the audio section.

# Digital TV Sound Processor (DTVSP)

# TDA9875A

### 6.3.1 ANALOG CROSSBAR SWITCH AND ANALOG MATRIX

There are a number of analog input and output ports with the TDA9875A (see Figs 6 and 8). Analog source selector switches are employed to provide the desired analog signal routing capability. The analog signal routing is performed by the analog crossbar switch section. A dual audio ADC provides the connection to the DSP section and a dual audio DAC provides the connection from the DSP section to the analog crossbar switch. The digital signal routing is performed by a digital crossbar switch.

The basic signal routing philosophy of the TDA9875A is that each switch handles two signal channels at the same time, e.g. left and right, language A and B, directly at the source.

Each source selector switch is followed by an analog matrix to perform further selection tasks, such as putting a signal from one input channel, say language A, to both output channels or for swapping left and right channels (see Fig.7).

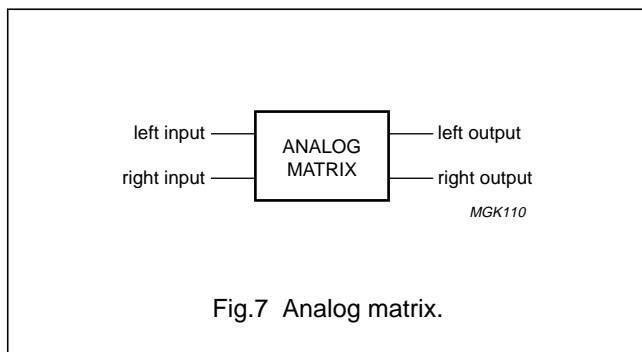

The analog matrix provides the functions given in Table 6.

**Table 6** Analog matrix functions

MODE	MATRIX OUTPUT	
	LEFT OUTPUT	RIGHT OUTPUT
1	left input	right input
2	right input	left input
3	left input	left input
4	right input	right input

All switches and matrices are controlled via the I<sup>2</sup>C-bus.

### 6.3.2 SCART INPUTS

The SCART specification allows for a signal level of up to 2 V (RMS). Because of signal handling limitations, due to the 5 V supply voltage of the TDA9875A, it is necessary to have fixed 3 dB attenuators at the SCART inputs to obtain a 2 V input. This results in a -3 dB SCART-to-SCART copy gain. If 0 dB copy gain is preferred (with a maximum input of 1.4 V), there are 0/3 dB amplifiers at the outputs of SCART 1 and SCART 2 and at the line output.

The input attenuator is realized by an external series resistor in combination with the input impedance, both of which form a voltage divider. With this voltage divider the maximum SCART signal level of 2 V (RMS) is scaled down to 1.4 V (RMS) at the input pin.

### 6.3.3 EXTERNAL AND MONO INPUTS

The 3 dB input attenuators are not required for the external and mono inputs, because those signal levels are under control of the TV designer. The maximum allowed input level is 1.4 V (RMS). By adding external series resistors, the external inputs can be used as an additional SCART input.

### 6.3.4 SCART OUTPUTS

The SCART outputs employ amplifiers with two gain settings. The gain can be set to 3 or 0 dB via the I<sup>2</sup>C-bus. The 3 dB position is needed to compensate for the 3 dB attenuation at the SCART inputs should SCART-to-SCART copies with 0 dB gain be preferred [under the condition of 1.4 V (RMS) maximum input level]. The 0 dB position is needed, for example, for an external-to-SCART copy with 0 dB gain.

---

## Digital TV Sound Processor (DTVSP)

## TDA9875A

---

### 6.3.5 LINE OUTPUT

The line output can provide an unprocessed copy of the audio signal in the loudspeaker channels. This can be either an external signal that comes from the dual audio ADC, or a signal from an internal digital audio source that comes from the dual audio DAC. The line output employs amplifiers with two gain settings. The 3 dB position is needed to compensate for the attenuation at the SCART inputs, while the 0 dB position is needed, for example, for non-attenuated external or internal digital signals (see Section 6.3.4).

### 6.3.6 LOUDSPEAKER (MAIN) AND HEADPHONE (AUXILIARY) OUTPUTS

Signals from any audio source can be applied to the loudspeaker and to the headphone output channels via the digital crossbar switch and the DSP.

### 6.3.7 DUAL AUDIO DAC

The TDA9875A contains three dual audio DACs, one for the connection from the DSP to the analog crossbar switch section and two for the loudspeaker and headphone outputs. Each of the three dual low-noise high-dynamic range DACs consists of two 15-bit DACs with current outputs, followed by a buffer operational amplifier. The audio DACs operate with four-fold oversampling and noise shaping.

### 6.3.8 DUAL AUDIO ADC

There is one dual audio ADC in the TDA9875A for the connection of the analog crossbar switch section to the DSP. The dual audio ADC consists of two bitstream third-order sigma-delta audio ADCs and a high-order decimation filter.

### 6.3.9 STANDBY MODE

The standby mode, selected by setting bit STDBY to logic 1 (see Section 10.3.2) disables most functions and reduces power dissipation. The analog crossbar switch and the SCART section remain operational and can be controlled by the I<sup>2</sup>C-bus to support copying of analog signals from SCART-to-SCART.

Unused internal registers may lose their information in the standby mode. Therefore, the device needs to be initialized on returning to the normal operating mode. This can be accomplished in the same way as after a Power-on reset.

### 6.3.10 SUPPLY GROUND

The different supply grounds  $V_{SS}$  are internally connected via the substrate. It is recommended to connect all ground pins by means of a copper plane close to the pins.

Digital TV Sound Processor (DTVSP)

TDA9875A

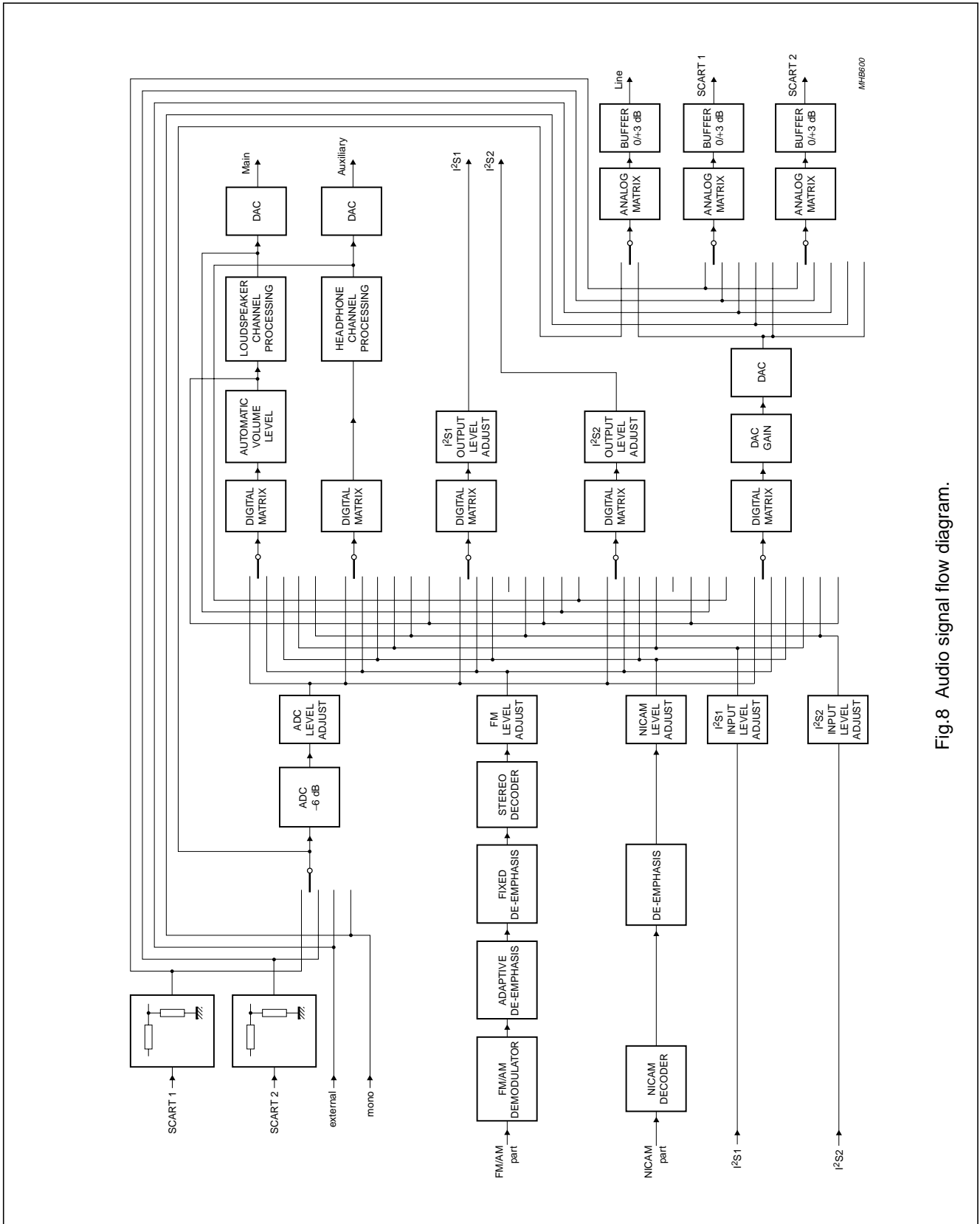

Fig.8 Audio signal flow diagram.

## Digital TV Sound Processor (DTVSP)

## TDA9875A

**7 LIMITING VALUES**

In accordance with the Absolute Maximum Rating System (IEC 134).

SYMBOL	PARAMETER	CONDITIONS	MIN.	MAX.	UNIT
$V_{DD}$	DC supply voltage		-0.5	+6.0	V
$\Delta V_{DD}$	voltage differences between two $V_{DD}$ pins		-	550	mV
$V_n$	voltage on any other pin		-0.5	$V_{DD} + 0.5$	V
$I_{DDD}, I_{SSD}$	DC current per digital supply pin		-	$\pm 180$	mA
$I_{lu(prot)}$	latch-up protection current		100	-	mA
$P_{tot}$	total power dissipation		-	1.0	W
$T_{stg}$	storage temperature		-55	+125	°C
$T_{amb}$	ambient temperature		-20	+70	°C
$V_{es}$	electrostatic handling voltage	note 1	-2000	+2000	V
		note 2	-200	+200	V

**Notes**

- Human body model: C = 100 pF; R = 1.5 k $\Omega$ .
- Machine model: C = 200 pF; L = 0.75  $\mu$ H; R = 0  $\Omega$ .

**8 THERMAL CHARACTERISTICS**

SYMBOL	PARAMETER	CONDITIONS	VALUE	UNIT
$R_{th(j-a)}$	thermal resistance from junction to ambient	in free air		
	TDA9875A (SDIP64)		40	K/W
	TDA9875AH (QFP64)		50	K/W

## Digital TV Sound Processor (DTVSP)

## TDA9875A

**9 CHARACTERISTICS**

$V_{SIF(p-p)} = 300$  mV; AGCOFF = 0; AGCSLOW = 0; AGCLEV = 0; level and gain settings in accordance with note 1;  $V_{DD} = 5$  V;  $T_{amb} = 25$  °C; settings in accordance with B/G standard; FM deviation  $\pm 50$  kHz;  $f_{mod} = 1$  kHz; FM sound parameters in accordance with system A2; NICAM in accordance with "EBU specification"; 1 k $\Omega$  measurement source resistance for AF inputs; with external components of Fig.10; unless otherwise specified.

SYMBOL	PARAMETER	CONDITIONS	MIN.	TYP.	MAX.	UNIT
<b>Supplies</b>						
$V_{DDD1}$	digital supply voltage 1		4.75	5.0	5.5	V
$V_{SSD1}$	digital supply ground 1	note 2	–	0.0	–	V
$I_{DDD1}$	digital supply current 1	$V_{DDD1} = 5.0$ V	58	73	88	mA
$V_{DDD2}$	digital supply voltage 2		4.75	5.0	5.5	V
$V_{SSD2}$	digital supply ground 2	note 2	–	0.0	–	V
$I_{DDD2}$	digital supply current 2	$V_{DDD2} = 5.0$ V; system clock output disabled	0.1	0.4	2	mA
$V_{SSD3}$	digital supply ground 3	note 2	–	0.0	–	V
$V_{SSD4}$	digital supply ground 4	note 2	–	0.0	–	V
$V_{DDA}$	analog supply voltage		4.75	5.0	5.5	V
$I_{DDA}$	analog supply current for DAC part	$V_{DDA} = 5.0$ V; digital silence	44	56	68	mA
$V_{SSA1}$	analog ground for analog front-end	note 2	–	0.0	–	V
$V_{SSA2}$	analog ground for audio ADC part	note 2	–	0.0	–	V
$V_{SSA3}$	analog ground for audio DAC part	note 2	–	0.0	–	V
$V_{SSA4}$	analog ground for SCART		–	0.0	–	V
<b>Demodulator supply decoupling and references</b>						
$V_{DEC1}$	analog supply decoupling voltage for demodulator part		3.0	3.3	3.6	V
$V_{ref1}$	analog reference voltage for demodulator part		–	2	–	V
$I_{ref1(sink)}$	sink current at pin $V_{ref1}$		–	200	–	$\mu$ A
<b>Audio supply decoupling and references</b>						
$V_{DEC2}$	analog supply decoupling voltage for audio ADC part		3.0	3.3	3.6	V
$V_{ref2}$	reference voltage ratio for audio ADCs	referenced to $V_{DEC2}$ and $V_{SSA2}$	–	50	–	%
$Z_{Vref2-VDEC2}$	impedance pins $V_{ref2}$ to $V_{DEC2}$		–	20	–	k $\Omega$
$Z_{Vref2-VSSA2}$	impedance pins $V_{ref2}$ to $V_{SSA2}$		–	20	–	k $\Omega$
$V_{ref3}$	reference voltage ratio for audio DAC and operational amplifier	referenced to $V_{DDA}$ and $V_{SSA3}$	–	50	–	%
$Z_{Vref3-VDDA}$	impedance pins $V_{ref3}$ to $V_{DDA}$		–	20	–	k $\Omega$
$Z_{Vref3-VSSA3}$	impedance pins $V_{ref3}$ to $V_{SSA3}$		–	20	–	k $\Omega$

## Digital TV Sound Processor (DTVSP)

## TDA9875A

SYMBOL	PARAMETER	CONDITIONS	MIN.	TYP.	MAX.	UNIT
<b>Power fail detector</b>						
$V_{th(pf)}$	power fail threshold voltage		–	3.9	–	V
<b>Digital inputs and outputs</b>						
INPUTS						
<i>CMOS level input, pull-down (pins TEST1 and TEST2)</i>						
$V_{IL}$	LOW-level input voltage		–	–	$0.3V_{DD}$	V
$V_{IH}$	HIGH-level input voltage		$0.7V_{DD}$	–	–	V
$C_i$	input capacitance		–	–	10	pF
$Z_i$	input impedance		–	50	–	k $\Omega$
<i>CMOS level input, hysteresis, pull-up (pin CRESET)</i>						
$V_{IL}$	LOW-level input voltage		–	–	$0.3V_{DD}$	V
$V_{IH}$	HIGH-level input voltage		$0.7V_{DD}$	–	–	V
$V_{hys}$	hysteresis voltage		–	1.3	–	V
$C_i$	input capacitance		–	–	10	pF
$Z_i$	input impedance		30	50	–	k $\Omega$
INPUTS/OUTPUTS						
<i>I<sup>2</sup>C-bus level input with Schmitt trigger, open-drain output stage, 400 kHz I<sup>2</sup>C-bus operation (pins SCL and SDA)</i>						
$V_{IL}$	LOW-level input voltage		–	–	$0.3V_{DD}$	V
$V_{IH}$	HIGH-level input voltage		$0.7V_{DD}$	–	–	V
$V_{hys}$	hysteresis voltage		–	$0.05V_{DD}$	–	V
$I_{LI}$	input leakage current		–	–	$\pm 10$	$\mu$ A
$C_i$	input capacitance		–	–	10	pF
$V_{OL}$	LOW-level output voltage		–	–	0.6	V
$C_L$	load capacitance		–	–	400	pF
<i>TTL/CMOS level, 4 mA 3-state output stage, pull-up (pins PCLK, NICAM, ADDR1, ADDR2, P1, P2, SCK, WS, SDO1, SDO2, SDI1 and SDI2)</i>						
$V_{IL}$	LOW-level input voltage		–	–	0.8	V
$V_{IH}$	HIGH-level input voltage		2.0	–	–	V
$C_i$	input capacitance		–	–	10	pF
$V_{OL}$	LOW-level output voltage		–	–	0.4	V
$V_{OH}$	HIGH-level output voltage		2.4	–	–	V
$C_L$	load capacitance		–	–	100	pF
$Z_i$	input impedance		–	50	–	k $\Omega$
OUTPUTS						
<i>CMOS level output, 4 mA 3-state output stage, slew rate controlled (pin SYSCLK)</i>						
$V_{OL}$	LOW-level output voltage		–	–	$0.3V_{DD}$	V
$V_{OH}$	HIGH-level output voltage		$0.7V_{DD}$	–	–	V
$C_L$	load capacitance		–	–	100	pF
$I_{LIZ}$	3-state leakage current	$V_i = 0$ to $V_{DD}$	–	–	$\pm 10$	$\mu$ A

## Digital TV Sound Processor (DTVSP)

## TDA9875A

SYMBOL	PARAMETER	CONDITIONS	MIN.	TYP.	MAX.	UNIT
<b>SIF1 and SIF2 analog inputs</b>						
$V_{\text{SIF(max)(p-p)}}$	maximum composite SIF input voltage for clipping (peak-to-peak value)	SIF input level adjust 0 dB	–	941	–	mV
		SIF input level adjust –10 dB	–	2976	–	mV
$V_{\text{SIF(min)(p-p)}}$	minimum composite SIF input voltage for lower limit of AGC (peak-to-peak value)	SIF input level adjust 0 dB	–	59	–	mV
		SIF input level adjust –10 dB	–	188	–	mV
AGC	AGC range		–	24	–	dB
$f_i$	input frequency		4	–	9.2	MHz
$R_i$	input resistance	AGCLEV = 0	10	–	–	k $\Omega$
$C_i$	input capacitance		–	7.5	11	pF
$\Delta f_{\text{FM}}$	FM deviation	B/G standard; THD < 1%	$\pm 100$	–	–	kHz
$\Delta f_{\text{FM(FS)}}$	FM deviation full-scale level	terrestrial FM; level adjust 0 dB	$\pm 150$	–	–	kHz
$C/N_{\text{FM}}$	FM carrier-to-noise ratio	$N_{\text{FM}}$ bandwidth = 6 MHz; white noise for S/N = 40 dB; "CCIR468"; quasi peak	–	77	–	$\frac{\text{dB}}{\text{Hz}}$
$C/N_{\text{N}}$	NICAM carrier-to-noise ratio	$N_{\text{N}}$ bandwidth = 6 MHz; bit error rate = $10^{-3}$ ; white noise	–	66	–	$\frac{\text{dB}}{\text{Hz}}$
$\alpha_{\text{ct}}$	crosstalk attenuation SIF1 to SIF2	$f_i = 4$ to 9.2 MHz; note 3	50	–	–	dB
<b>Demodulator performance</b>						
THD + N	total harmonic distortion plus noise	from FM source to any output; $V_o = 1$ V (RMS) with low-pass filter	–	0.3	0.5	%
		from NICAM source to any output; $V_o = 1$ V (RMS) with low-pass filter	–	0.1	0.3	%
S/N	signal-to-noise ratio	SC1 from FM source to any output; $V_o = 1$ V (RMS); "CCIR468"; quasi peak	64	70	–	dB
		SC2 from FM source to any output; $V_o = 1$ V (RMS); "CCIR468"; quasi peak	60	66	–	dB
		NICAM source; $V_o = 1$ V (RMS); note 4	–	–	–	
$B_{-3\text{dB}}$	–3 dB bandwidth	from FM source to any output	14.5	15	–	kHz
		from NICAM source to any output	14.5	15	–	kHz
$f_{\text{res}}$	frequency response 20 Hz to 14 kHz	from FM or NICAM to any output; $f_{\text{ref}} = 1$ kHz; inclusive pre-emphasis and de-emphasis	–	$\pm 2$	–	dB



## Digital TV Sound Processor (DTVSP)

## TDA9875A

SYMBOL	PARAMETER	CONDITIONS	MIN.	TYP.	MAX.	UNIT
$\alpha_{CS(dual)}$	dual signal channel separation	note 5	65	70	–	dB
$\alpha_{CS(stereo)}$	stereo channel separation	note 6	40	45	–	dB
$\alpha_{AM}$	AM suppression for FM	AM: 1 kHz, 30% modulation; reference: 1 kHz, 50 kHz deviation	50	–	–	dB
$S/N_{AM}$	AM demodulation	SIF level 100 mV (RMS); 54% AM; 1 kHz AF; "CCIR468"; quasi peak	36	45	–	dB
IDENTIFICATION FOR FM SYSTEMS						
$mod_p$	pilot modulation for identification		25	50	75	%
$C/N_p$	pilot sideband carrier-to-noise ratio for identification start		–	27	–	dB Hz
$f_{ident}$	identification window	B/G stereo				
		slow mode	116.85	–	118.12	Hz
		medium mode	116.11	–	118.89	Hz
		fast mode	114.65	–	120.46	Hz
		B/G dual				
		slow mode	273.44	–	274.81	Hz
	medium mode	272.07	–	276.20	Hz	
	fast mode	270.73	–	277.60	Hz	
$t_{ident(on)}$	total identification time ON	slow mode	–	–	2	s
		medium mode	–	–	1	s
		fast mode	–	–	0.5	s
$t_{ident(off)}$	total identification time OFF	slow mode	–	–	2	s
		medium mode	–	–	1	s
		fast mode	–	–	0.5	s
<b>Analog audio inputs</b>						
MONO INPUT AND EXTERNAL INPUT						
$V_{i(nom)(rms)}$	nominal level input voltage (RMS value)		–	500	–	mV
$V_{i(clip)(rms)}$	clipping level input voltage (RMS value)	THD < 3%; note 7	1250	1400	–	mV
$R_i$	input resistance	note 7	28	35	42	k $\Omega$
SCART INPUTS						
$V_{i(nom)(rms)}$	nominal level input voltage at input pin (RMS value)	–3 dB divider with external 15 k $\Omega$ resistor; note 8	–	350	–	mV
$V_{i(clip)(rms)}$	clipping level input voltage at input pin (RMS value)	–3 dB divider with external 15 k $\Omega$ resistor; THD < 3%; notes 7 and 8	1250	1400	–	mV
$R_i$	input resistance	note 7	28	35	42	k $\Omega$

## Digital TV Sound Processor (DTVSP)

## TDA9875A

SYMBOL	PARAMETER	CONDITIONS	MIN.	TYP.	MAX.	UNIT
<b>Analog audio outputs</b>						
LOUDSPEAKER (MAIN) AND HEADPHONE (AUXILIARY) OUTPUTS						
$V_{o(\text{clip})(\text{rms})}$	clipping level output voltage (RMS value)	THD < 3%	1250	1400	–	mV
$R_o$	output resistance		150	250	375	$\Omega$
$R_{L(\text{AC})}$	AC load resistance		10	–	–	k $\Omega$
$R_{L(\text{DC})}$	DC load resistance		10	–	–	k $\Omega$
$C_L$	load capacitance		–	10	12	nF
$V_{\text{offset}(\text{DC})}$	static DC offset voltage		–	30	70	mV
$\alpha_{\text{mute}}$	mute suppression	nominal input signal from any source; $f_i = 1$ kHz	80	–	–	dB
$G_{\text{ro}(\text{main,aux})}$	roll-off gain at 14.5 kHz for Main and Auxiliary channels	from any source	–3	–2	–	dB
$\text{PSRR}_{\text{main,aux}}$	power supply ripple rejection for Main and Auxiliary channels	$f_{\text{ripple}} = 70$ Hz; $V_{\text{ripple}} = 100$ mV (peak); $C_{V\text{ref}} = 47$ $\mu\text{F}$ ; signal from I <sup>2</sup> S-bus	40	45	–	dB
SCART OUTPUTS AND LINE OUTPUT						
$V_{o(\text{nom})(\text{rms})}$	nominal level output voltage (RMS value)	3 dB amplification	–	500	–	mV
$V_{o(\text{clip})(\text{rms})}$	clipping level output voltage (RMS value)	THD < 3%	1250	1400	–	mV
$R_o$	output resistance		150	250	375	$\Omega$
$R_{L(\text{AC})}$	AC load resistance		10	–	–	k $\Omega$
$R_{L(\text{DC})}$	DC load resistance		10	–	–	k $\Omega$
$C_L$	load capacitance		–	–	2.5	nF
$V_{\text{offset}(\text{DC})}$	static DC offset voltage	output amplifiers at 3 dB position	–	30	50	mV
$\alpha_{\text{mute}}$	mute suppression	nominal input signal from any source; $f_i = 1$ kHz	80	–	–	dB
B	bandwidth	from SCART, external and mono sources; –3 dB bandwidth	20	–	–	kHz
		from DSP sources; –3 dB bandwidth	14.5	–	–	kHz
PSRR	power supply ripple rejection	$f_{\text{ripple}} = 70$ Hz; $V_{\text{ripple}} = 100$ mV (peak); $C_{V\text{ref}} = 47$ $\mu\text{F}$ ; signal from I <sup>2</sup> S-bus	40	45	–	dB

## Digital TV Sound Processor (DTVSP)

## TDA9875A

SYMBOL	PARAMETER	CONDITIONS	MIN.	TYP.	MAX.	UNIT
<b>Audio performance</b>						
THD + N	total harmonic distortion plus noise	$V_i = V_o = 1$ V (RMS); $f_i = 1$ kHz; bandwidth 20 Hz to 15 kHz; note 9				
		from any analog audio input to I <sup>2</sup> S-bus	–	0.1	0.3	%
		from I <sup>2</sup> S-bus to any analog audio output	–	0.1	0.3	%
		SCART-to-SCART copy	–	0.1	0.3	%
		SCART-to-Main copy	–	0.2	0.5	%
S/N	signal-to-noise ratio	reference voltage $V_o = 1.4$ V (RMS); $f_i = 1$ kHz; "CCIR468"; quasi peak; note 9				
		from any analog audio input to I <sup>2</sup> S-bus	73	77	–	dB
		from I <sup>2</sup> S-bus to any analog audio output	78	85	–	dB
		SCART-to-SCART copy	78	85	–	dB
		SCART-to-Main copy	73	77	–	dB
$\alpha_{ct}$	crosstalk attenuation	between any analog input pairs; $f_i = 1$ kHz	70	–	–	dB
		between any analog output pairs; $f_i = 10$ kHz	65	–	–	dB
$\alpha_{cs}$	channel separation	between left and right of any input pair	65	–	–	dB
		between left and right of any output pair	60	–	–	dB
$G_A$	gain from SCART-to-SCART with –3 dB input voltage divider	output amplifier in 3 dB position; $R_{ext} = 15$ k $\Omega \pm 10\%$	–1.5	0	+1.1	dB
		output amplifier in 0 dB position; $R_{ext} = 15$ k $\Omega \pm 10\%$	–4.5	–3.0	–1.9	dB
<b>Crystal specification (fundamental mode)</b>						
$f_{xtal}$	crystal frequency		–	24.576	–	MHz
$C_L$	load capacitance		–	20	–	pF
$C_1$	series capacitance		–	20	–	fF
$C_0$	parallel capacitance		–	–	7	pF
$\Phi_{pull}$	pulling sensitivity	$C_L$ changed from 18 to 16 pF	–	25	–	$\frac{10^{-6}}{pF}$
$R_R$	equivalent series resistance	at nominal frequency	–	–	30	$\Omega$
$R_N$	equivalent series resistance of unwanted mode		$2R_R$	–	–	$\Omega$
$\Delta T$	temperature range		–20	+25	+70	$^{\circ}C$

## Digital TV Sound Processor (DTVSP)

## TDA9875A

SYMBOL	PARAMETER	CONDITIONS	MIN.	TYP.	MAX.	UNIT
X <sub>J</sub>	adjustment tolerance		–	–	±30	10 <sup>-6</sup>
X <sub>D</sub>	drift	across temperature range	–	–	±30	10 <sup>-6</sup>
X <sub>A</sub>	ageing		–	–	±5	$\frac{10^{-6}}{\text{year}}$

**Notes**

- Definitions of levels and level setting:
  - The full-scale level for analog audio signals is 1.4 V (RMS).
  - The nominal level at the digital crossbar switch is defined at –15 dB (full-scale).
  - Nominal audio input levels for external and mono: 500 mV (RMS) at –9 dB (full-scale).
  - See also Tables 7 and 8.
- All analog and digital supply ground pins are connected internally.
- Set demodulator to AM mode. Apply an AM carrier (with 1 kHz and 100%) to one channel. Check AGC step. Switch AGC off and set AGC to the gain step found. Measure the 1 kHz signal level of this channel and take it as a reference. Switch to the other SIF input to which no signal is connected and which is terminated with 50 Ω. Now measure the 1 kHz crosstalk signal level. The SIF source resistance should be low (50 Ω).
- NICAM in accordance with "EBU specification". Audio performance is limited by the dynamic range of the NICAM728 system. Due to compansion, the quantization noise is never lower than –62 dB (unweighted RMS) with respect to the input level.
- FM source; in dual mode only A (respectively B) signal modulated; measured at B (respectively A) channel output; V<sub>o</sub> = 1 V (RMS) of modulated channel.
- FM source; in stereo mode only L (respectively R) signal modulated; measured at R (respectively L) channel output; V<sub>o</sub> = 1 V (RMS) of modulated channel. The stereo channel separation may be limited by adjustment tolerances of the transmitter.
- If the supply voltage for the TDA9875A is switched off, because of the ESD protection circuitry, all audio input pins are short-circuited. To avoid a short-circuit at the SCART inputs a 15 kΩ resistor (–3 dB divider) has to be used.
- The SCART specification allows a signal level of up to 2 V (RMS). Because of signal handling limitations due to the 5 V supply voltage for the TDA9875A, there is a need for fixed 3 dB attenuators at the SCART inputs. To achieve SCART-to-SCART copies with 0 dB gain, there are 3 dB/0 dB amplifiers at the outputs of SCART 1 and SCART 2 and at the line output. The attenuator is realized by an internal resistor that works together with an external series resistor as a voltage divider. With this voltage divider the maximum SCART input signal level of 2 V (RMS) is scaled down to 1.4 V (RMS) at the input pin. To avoid clipping, the 3 dB gain must not be used if the SCART input signal is larger than 1.4 V (RMS).
- ADC level adjust is 6 dB, all other level adjusts are 0 dB. If an external –3 dB divider is used set output buffer gain to 3 dB, tone control to 0 dB, AVL off and volume control to 0 dB.

## Digital TV Sound Processor (DTVSP)

## TDA9875A

Table 7 Level setting FM, AM and NICAM at 0 dB (full-scale) = 1.4 V (RMS); note 1

STANDARD	MODE	TRANSMITTER NOMINAL MODULATION DEPTH	NOMINAL LEVEL AT DEMULATOR OUTPUT	CARRIER	FREQUENCY	MODE	IDENT	DE-EMPHASIS	FM/NICAM LEVEL ADJUST
M	2 channel	15 kHz deviation	-24 dB (full-scale); note 2	1	4.5 MHz	FM	-	75 $\mu$ s	+9 dB
				2	4.724 MHz	FM	on	75 $\mu$ s	+9 dB
B/G	2 channel	27 kHz deviation	-19 dB (full-scale)	1	5.5 MHz	FM	-	50 $\mu$ s	+4 dB
				2	5.742 MHz	FM	on	50 $\mu$ s	+4 dB
I	NICAM	-11.2 dB (full-scale)	-18 dB (full-scale)	1	5.5 MHz	FM	-	50 $\mu$ s	+4 dB
				2	5.85 MHz	NICAM	off	J17	+3 dB
D/K	2 channel	27 kHz deviation	-23 dB (full-scale)	1	6.0 MHz	FM	-	50 $\mu$ s	+4 dB
				2	6.552 MHz	NICAM	off	J17	+8 dB
D/K	2 channel	27 kHz deviation	-19 dB (full-scale)	1	6.5 MHz	FM	-	50 $\mu$ s	+4 dB
				2	6.742 MHz	FM	on	50 $\mu$ s	+4 dB
D/K	2 channel	27 kHz deviation	-19 dB (full-scale)	1	6.5 MHz	FM	-	50 $\mu$ s	+4 dB
				2	6.25 MHz	FM	on	50 $\mu$ s	+4 dB
L/L accent	NICAM	54% AM	-19 dB (full-scale)	1	6.5 MHz	FM	-	50 $\mu$ s	+4 dB
				2	5.742 MHz	FM	on	50 $\mu$ s	+4 dB
L/L accent	NICAM	54% AM	-18 dB (full-scale)	1	6.5 MHz	FM	-	50 $\mu$ s	+4 dB
				2	5.85 MHz	NICAM	off	J17	+3 dB
L/L accent	NICAM	54% AM	-19 dB (full-scale)	1	6.5 MHz	AM	-	50 $\mu$ s	+5 dB
				2	5.85 MHz	NICAM	off	J17	+3 dB

## Notes

- Nominal level at digital crossbar is defined at -15 dB (full-scale). DAC gain setting 6 dB. Output buffer setting 0 dB. Nominal SCART output level 500 mV (RMS).
- For stereo signals the output level is 6 dB lower. The level adjust has to be increased by 6 dB.

Digital TV Sound Processor (DTVSP)

TDA9875A

**Table 8** Level setting SAT FM at 0 dB (full-scale) = 1.4 V (RMS)

SOURCE	TRANSMITTER MAXIMUM MODULATION DEPTH	NOMINAL LEVEL AT DEMODULATOR OUTPUT	FM LEVEL ADJUST SETTING	MAXIMUM LEVEL AT CROSSBAR	DAC GAIN SETTING	OUTPUT BUFFER	NOMINAL SCART OUTPUT VOLTAGE
SAT FM, stereo	50 kHz deviation	-13 dB (full-scale)	+4 dB	-9 dB (full-scale)	+6 dB	0 dB	1 V (RMS)
SAT FM, mono	85 kHz deviation	-9 dB (full-scale)	0 dB				

## Digital TV Sound Processor (DTVSP)

## TDA9875A

**10 I<sup>2</sup>C-BUS CONTROL****10.1 Introduction**

The TDA9875A is fully controlled via the I<sup>2</sup>C-bus. Control is exercised by writing data to one or more internal registers. Status information can be read from an array of registers to enable the controlling microcontroller to determine whether any action is required.

The device has an I<sup>2</sup>C-bus slave transceiver, in accordance with the fast-mode specification, with a maximum speed of 400 kbits/s. Information concerning the I<sup>2</sup>C-bus can be found in brochure "I<sup>2</sup>C-bus and how to use it" (order number 9398 393 40011). To avoid conflicts in a real application with other ICs providing similar or complementary functions, there are four possible slave addresses available which can be selected by pins ADDR1 and ADDR2 (see Table 9).

**Table 9** Possible slave addresses

ADDR2	ADDR1	SLAVE ADDRESS						
		A6	A5	A4	A3	A2	A1	A0
LOW	LOW	1	0	1	1	0	0	0
LOW	HIGH	1	0	1	1	0	0	1
HIGH	LOW	1	0	1	1	0	1	0
HIGH	HIGH	1	0	1	1	0	1	1

The I<sup>2</sup>C-bus interface remains operational in the standby mode of the TDA9875A to allow control of the analog source selectors with regard to SCART-to-SCART copying.

The device will not respond to a 'general call' on the I<sup>2</sup>C-bus, i.e. when a slave address of 0000000 is sent by a master.

The data transmission between the microcontroller and the other I<sup>2</sup>C-bus controlled ICs is not disturbed when the supply voltage of the TDA9875A is not connected.

**10.2 Power-up state**

At power-up the device is in the following state:

- All outputs muted
- No sound carrier frequency loaded
- General-purpose I/O pins ready for input (HIGH)
- Input SIF1 selected with:
  - AGC on
  - Small hysteresis
  - SIF input level shift 0 dB.
- Demodulators for both sound carriers set to FM with:
  - Identification for B/G and D/K, response time 1 s
  - Level adjust set to 0 dB
  - De-emphasis 50 µs
  - Matrix set to mono.
- Main channel set to FM input with:
  - Spatial off
  - Pseudo off
  - AVL off
  - Volume mute
  - Bass flat
  - Treble flat
  - Contour off
  - Bass boost flat.
- Auxiliary channel set to FM input with:
  - Volume mute
  - Bass flat
  - Treble flat.
- Feature interface all outputs off
- Beeper off
- Monitoring of carrier 1 FM demodulator DC output.

After power-up a device initialization has to be performed via the I<sup>2</sup>C-bus to put the TDA9875A into the proper mode of operation, in accordance with the desired TV standard, audio control settings, etc.

## Digital TV Sound Processor (DTVSP)

## TDA9875A

**10.3 Slave receiver mode**

As a slave receiver, the TDA9875A provides 46 registers for storing commands and data. These registers are accessed via so-called subaddresses. A subaddress can be thought of as a pointer to an internal memory location.

**Table 10** I<sup>2</sup>C-bus; slave address, subaddress and data format

S	SLAVE ADDRESS	0	ACK	SUBADDRESS	ACK	DATA	ACK	P
---	---------------	---	-----	------------	-----	------	-----	---

**Table 11** Explanation of Table 10

BIT	FUNCTION
S	START condition
SLAVE ADDRESS	7-bit device address
0	data direction bit (write to device)
ACK	acknowledge by slave
SUBADDRESS	address of register to write to
DATA	data byte to be written into register
P	STOP condition

It is allowed to send more than one data byte per transmission to the TDA9875A. In this event, the subaddress is automatically incremented after each data byte, resulting in storing the sequence of data bytes at successive register locations, starting at SUBADDRESS. A transmission can start at any valid subaddress. Each byte is acknowledged with ACK (acknowledge).

There is no 'wrap-around' of subaddresses.

Commands and data are processed as soon as they have been completely received. Functions requiring more than one byte will, thus, be executed only after all bytes for that function have been received. If the transmission is terminated (STOP condition) before all bytes have been received, the incomplete data for that function are ignored.

**Table 12** Format for a transmission employing auto-increment of subaddresses

S	SLAVE ADDRESS	0	ACK	SUBADDRESS	ACK	DATA BYTE A <sup>(1)</sup>	DATA	ACK	P
---	---------------	---	-----	------------	-----	-------------------------------	------	-----	---

**Note**

1. n data bytes with auto-increment of subaddresses.

Data patterns sent to the various subaddresses are not checked for being illegal or not at that address, except for the functions of volume, bass, treble control, bass boost and level adjust.

Detection of a STOP condition without a preceding acknowledge bit is regarded as a bus error. The last operation will then not be executed.



## Digital TV Sound Processor (DTVSP)

## TDA9875A

Table 13 Overview of the slave receiver registers

SUBADDRESS (DECIMAL)	DATA								FUNCTION
	MSB							LSB	
0	0	0	s	g	g	g	g	g	AGC level shift, AGC gain selection
1	c	c	c	c	c	c	c	c	general configuration
2	p	0	0	m	m	s	s	s	monitor select, peak detector on/off
3	f	f	f	f	f	f	f	f	carrier 1 frequency; most significant part
4	f	f	f	f	f	f	f	f	carrier 1 frequency
5	f	f	f	f	f	f	f	f	carrier 1 frequency; least significant part
6	f	f	f	f	f	f	f	f	carrier 2 frequency; most significant part
7	f	f	f	f	f	f	f	f	carrier 2 frequency
8	f	f	f	f	f	f	f	f	carrier 2 frequency; least significant part
9	c	c	c	c	c	c	c	c	demodulator configuration
10	d	d	d	d	d	d	d	d	FM de-emphasis
11	0	0	0	0	0	m	m	m	FM matrix
12	0	0	0	l	l	l	l	l	channel 1 output level adjust
13	0	0	0	l	l	l	l	l	channel 2 output level adjust
14	t	t	0	c	0	c	c	c	NICAM configuration
15	0	0	0	l	l	l	l	l	NICAM output level adjust
16	l	l	l	l	l	l	l	l	NICAM lower error limit
17	u	u	u	u	u	u	u	u	NICAM upper error limit
18	m	m	m	m	m	m	m	m	audio mute control
19	g	m	m	m	g	s	s	s	DAC output select
20	0	g	m	m	0	s	s	s	SCART 1 output select
21	0	g	m	m	0	s	s	s	SCART 2 output select
22	0	g	m	m	0	0	0	s	line output select
23	s	s	s	l	l	l	l	l	ADC output select
24	0	m	m	m	0	s	s	s	Main channel select
25	0	0	s	s	p	p	a	a	audio effects (AVL, pseudo and spatial)
26	v	v	v	v	v	v	v	v	volume control, Main left
27	v	v	v	v	v	v	v	v	volume control, Main right
28	0	0	0	c	c	c	c	c	contour control, Main
29	0	0	0	b	b	b	b	b	bass control, Main
30	0	0	0	t	t	t	t	t	treble control, Main
31	0	m	m	m	0	s	s	s	Auxiliary channel select
32	v	v	v	v	v	v	v	v	volume control, Auxiliary left
33	v	v	v	v	v	v	v	v	volume control, Auxiliary right
34	0	0	0	b	b	b	b	b	bass control, Auxiliary
35	0	0	0	t	t	t	t	t	treble control, Auxiliary
36	0	0	0	c	c	c	c	c	feature interface configuration
37	0	m	m	m	0	s	s	s	I <sup>2</sup> S1 output select

## Digital TV Sound Processor (DTVSP)

## TDA9875A

SUBADDRESS (DECIMAL)	DATA								FUNCTION
	MSB							LSB	
38	0	0	0	i	i	i	i	i	I <sup>2</sup> S1 input level adjust
39	0	0	0	o	o	o	o	o	I <sup>2</sup> S1 output level adjust
40	0	m	m	m	0	s	s	s	I <sup>2</sup> S2 output select
41	0	0	0	i	i	i	i	i	I <sup>2</sup> S2 input level adjust
42	0	0	0	o	o	o	o	o	I <sup>2</sup> S2 output level adjust
43	0	0	0	0	0	f	f	f	beeper frequency
44	0	0	v	v	v	v	v	v	beeper volume, Main and Auxiliary
45	b	b	b	b	b	b	b	b	bass boost, Main left and right

The following sub-sections provide a detailed description of the slave receiver registers.

#### 10.3.1 AGC GAIN REGISTER

If the automatic gain control function is switched off in the general configuration register, the contents of this register will define a fixed gain of the AGC stage. The input voltages given are meant to generate a full-scale output from the SIF ADC. If automatic gain control is on, the AGCGAIN setting is ignored. After switching off the automatic gain control function, the latest gain control setting is copied to the AGC gain register.

If the AGC input level shift bit AGCLEV is set to logic 1 the input signal is scaled with –10 dB. The AGCLEV bit is also active if the automatic gain function is enabled.

It should be noted that the input voltages should be considered as approximate target values.

**Table 14** Subaddress 0 (note 1)

BIT	NAME	VALUE	DESCRIPTION
7 (MSB)	B7	0	set to logic 0
6	B6	0	set to logic 0
5	AGCLEV	1	input signal scaled with –10 dB
		0	input signal not scaled
4	AGCGAIN	–	gain control bits (see Table 15)
3			
2			
1			
0 (LSB)			

#### Note

1. The default setting at power-up is 0000 0000.

## Digital TV Sound Processor (DTVSP)

## TDA9875A

Table 15 Gain control bits

MSB							LSB	AGC GAIN (dB)	SIF INPUT VOLTAGE [mV (p-p)]
B7	B6	B5	B4	B3	B2	B1	B0		
0	0	0/1	1	1	1	1	1	0.0	941/2976
0	0	0/1	1	1	1	1	0	0.8	861/2723
0	0	0/1	1	1	1	0	1	1.5	788/2490
0	0	0/1	1	1	1	0	0	2.3	720/2278
0	0	0/1	1	1	0	1	1	3.1	659/2084
0	0	0/1	1	1	0	1	0	3.9	603/1906
0	0	0/1	1	1	0	0	1	4.6	551/1744
0	0	0/1	1	1	0	0	0	5.4	504/1595
0	0	0/1	1	0	1	1	1	6.2	461/1459
0	0	0/1	1	0	1	1	0	7.0	422/1334
0	0	0/1	1	0	1	0	1	7.7	386/1221
0	0	0/1	1	0	1	0	0	8.5	353/1117
0	0	0/1	1	0	0	1	1	9.3	323/1021
0	0	0/1	1	0	0	1	0	10.1	295/934
0	0	0/1	1	0	0	0	1	10.8	270/855
0	0	0/1	1	0	0	0	0	11.6	247/782
0	0	0/1	0	1	1	1	1	12.4	226/715
0	0	0/1	0	1	1	1	0	13.2	207/654
0	0	0/1	0	1	1	0	1	13.9	189/598
0	0	0/1	0	1	1	0	0	14.7	173/547
0	0	0/1	0	1	0	1	1	15.5	158/501
0	0	0/1	0	1	0	1	0	16.3	145/458
0	0	0/1	0	1	0	0	1	17.0	132/419
0	0	0/1	0	1	0	0	0	17.8	121/383
0	0	0/1	0	0	1	1	1	18.6	111/350
0	0	0/1	0	0	1	1	0	19.4	101/321
0	0	0/1	0	0	1	0	1	20.1	93/293
0	0	0/1	0	0	1	0	0	20.9	85/268
0	0	0/1	0	0	0	1	1	21.7	78/245
0	0	0/1	0	0	0	1	0	22.5	71/224
0	0	0/1	0	0	0	0	1	23.2	65/205
0	0	0/1	0	0	0	0	0	24.0	59/188 (note 1)

**Note**

1. The default setting at power-up is 0000 0000.

## Digital TV Sound Processor (DTVSP)

## TDA9875A

## 10.3.2 GENERAL CONFIGURATION REGISTER

**Table 16** Subaddress 1 (note 1)

BIT	NAME	VALUE	DESCRIPTION
7 (MSB)	P2OUT	–	This bit controls the general purpose input/output pin P2. The contents of this bit is written directly to the corresponding pin. If input is desired, the bit must be set to logic 1 to allow the pin to be pulled LOW externally. Input from the pin is reflected in the device status register (see Section 10.4.1).
6	P1OUT	–	This bit controls the general purpose input/output pin P1. The contents of this bit is written directly to the corresponding pin. If input is desired, the bit must be set to logic 1 to allow the pin to be pulled LOW externally. Input from the pin is reflected in the device status register (see Section 10.4.1). P1OUT is recommended to be used for switching an SIF trap for the adjacent picture carrier in designs that employ such a trap.
5	STDBY	1	The IC is in the standby mode. Most functions are disabled and power dissipation is somewhat reduced, but the analog selectors/matrices remain operational to support analog copying from SCART-to-SCART.
		0	The IC is in the normal operating mode. On return from standby mode, the device is in its Power-on reset mode and needs to be re-initialized.
4	INIT	1	Causes initialization of the TDA9875A to its default settings. This has the same effect as a Power-on reset. If there is a conflict between the default settings and any bit set to logic 1 in this register, the bits of this register have priority over the corresponding default setting.
		0	Automatically reset to logic 0 after initialization. When set to logic 0, the TDA9875A is in its normal operating mode.
3	CLRPOR	1	Resets the power fail detector to LOW.
		0	This bit is automatically reset to logic 0 after bit POR in the device status register has been reset.
2	AGCSLOW	1	A longer decay time is selected for input signals with strong video modulation (intercarrier). This bit only has an effect when bit AGCOFF = 0.
		0	Selects normal attack and decay times for the AGC.
1	AGCOFF	1	Forces the AGC block to a fixed gain as defined in the AGC gain register.
		0	The automatic gain control function is enabled and the contents of the AGC gain register is ignored.
0 (LSB)	SIFSEL	1	Selects pin SIF2 for input (recommended for satellite tuner).
		0	Selects pin SIF1 for input (terrestrial TV).

**Note**

1. The default setting at power-up is 1100 0000.

## Digital TV Sound Processor (DTVSP)

## TDA9875A

## 10.3.3 MONITOR SELECT REGISTER

This register is used to define the signal source, the level of which is to be monitored, and if the peak level is to be monitored. Peak level refers to the magnitude of the maximum excursion of a signal.

Audio magnitude/phase is related to the FM demodulator output. Phase information is provided, when it operates in FM mode, while magnitude is supplied in AM mode.

Data can be read-out in the I<sup>2</sup>C-bus slave transmitter mode. By reading out level read-out registers (see Section 10.4) the current peak level will be reset.

Table 17 Subaddress 2 (note 1)

BIT	NAME	VALUE	DESCRIPTION
7 (MSB)	PEAKMON	1	selects the peak level of a source to be monitored
		0	the last sample will be supplied
6	B6	0	default value
5	B5	0	default value
4	B4	–	monitor output (see Table 18)
3	B3		
2	B2	–	signal source (see Table 19)
1	B1		
0 (LSB)	B0		

**Note**

1. The default setting at power-up is 0000 0000.

Table 18 Monitor output

B4	B3	MONITOR OUTPUT
0	0	$\frac{L \text{ input} + R \text{ input}}{2}$
0	1	L input (channel 1, respectively)
1	0	R input (channel 2, respectively)

Table 19 Signal source (note 1)

B2	B1	B0	SIGNAL SOURCE
0	0	0	DC output of FM demodulator
0	0	1	audio magnitude/phase, FM demodulator output
0	1	0	crossbar input from FM/AM channel
0	1	1	crossbar input from NICAM channel
1	0	0	crossbar input from I <sup>2</sup> S1 channel
1	0	1	crossbar input from I <sup>2</sup> S2 channel
1	1	0	crossbar input from audio ADC channel
1	1	1	input to Main channel DAC (without beeper)

**Note**

1. The term 'crossbar' refers to the digital selector, where level-adjusted signals from various sources are available.

## Digital TV Sound Processor (DTVSP)

## TDA9875A

## 10.3.4 CARRIER 1 FREQUENCY REGISTER

The three bytes together constitute a 24-bit frequency control word to represent the sound carrier (i.e. mixer) frequency in accordance with the following formula:

$$\text{data} = \frac{f_{\text{mix}}}{f_{\text{clk}}} \times 2^{24}$$

where:

data = 24-bit frequency control word

$f_{\text{mix}}$  = desired sound carrier frequency

$f_{\text{clk}}$  = 12.288 MHz (clock frequency of mixer)

$2^{24}$  = 16777216 (number of steps in a 24-bit word size).

Example: A 5.5 MHz sound carrier frequency will be generated by sending the following sequence of data bytes to the TDA9875A (data = 7509333 in decimal notation or 72555 in hexadecimal):  
01110010 10010101 01010101.

As three bytes are required to define a carrier frequency, execution of this command starts only after all bytes have been received. If an error occurs, e.g. a premature STOP condition, partial data for this function is ignored.

The default setting at power-up is 0000 0000 for all three bytes.

Most significant part at subaddress 3 and least significant part at subaddress 5 (see Table 20).

**Table 20** Subaddresses 3 to 5

SUB-ADDRESS	BIT	DESCRIPTION
3	7 (MSB)	carrier 1 frequency; most significant part
	6	
	5	
	4	
	3	
	2	
	1	
	0	
4	7	carrier 1 frequency
	6	
	5	
	4	
	3	
	2	
	1	
	0	
5	7	carrier 1 frequency; least significant part
	6	
	5	
	4	
	3	
	2	
	1	
	0 (LSB)	

## Digital TV Sound Processor (DTVSP)

## TDA9875A

## 10.3.5 CARRIER 2 FREQUENCY REGISTER

Same as for sound carrier 1, except for subaddresses (subaddresses 6 to 8). If the carrier 2 frequency register is used, it will be for either the second FM sound carrier of a terrestrial or satellite FM program or the NICAM sound carrier.

## 10.3.6 DEMODULATOR CONFIGURATION REGISTER

It is recommended to switch the FM sound mode identification off whenever the received program is not a terrestrial 2-carrier sound. Switching the identification off will reset the associated hardware to a defined state.

**Table 21** Subaddress 9 (note 1)

BIT	NAME	VALUE	DESCRIPTION
7 (MSB)	IDMOD1	–	these bits define the response time after which a FM sound mode identification result may be expected; the longer the time, the more reliable the identification (see Table 22)
6	IDMOD0		
5	IDAREA	1	selects FM identification frequencies in accordance with the specification for Korea
		0	selects frequencies for Europe (B/G and D/K standard)
4	FILTBW1	–	selects filter bandwidth (see Table 23)
3	CH2MOD1	–	channel 2 receive mode: these bits control the hardware for the second sound carrier (see Table 24); the NICAM mode employs a wider bandwidth of the decimation filters than the FM mode
2	CH2MOD0		
1	FILTBW0	–	selects the filter bandwidth (see Table 23)
0 (LSB)	CH1MODE	1	selects the hardware for the first sound carrier to operate in AM mode
		0	FM mode is assumed; this applies to both terrestrial and satellite FM reception

**Notes**

1. The default setting at power-up is 0000 0000.

**Table 22** Identification mode

B7	B6	IDENT MODE
0	0	slow
0	1	medium
1	0	fast
1	1	off/reset

**Table 23** Filter bandwidth channel 1 and channel 2

B4	B1	FILTER BANDWIDTH		FILTER MODES
		CH1	CH2	
0	0	narrow	narrow	recommended for nominal terrestrial broadcast conditions and SAT with 2 carriers
0	1	extra wide	narrow	recommended only for high-deviation SAT mono carriers (e.g. obsolete Main channel on Astra)
1	0	medium	medium	recommended for moderately overmodulated broadcast conditions
1	1	wide	wide	recommended for strongly overmodulated broadcast conditions

## Digital TV Sound Processor (DTVSP)

## TDA9875A

**Table 24** Channel 2 receive mode

B3	B2	CHANNEL 2
0	0	FM
0	1	AM
1	0	NICAM

## 10.3.7 FM DE-EMPHASIS REGISTER

This register is used to select the proper de-emphasis characteristics as appropriate for the standard of the received carrier. Bits B3 to B0 apply to sound carrier 1, bits B7 to B4 apply to sound carrier 2.

In the event of A2 reception, both groups must be set to the same characteristics.

**Table 25** Subaddress 10 (note 1)

BIT	NAME	VALUE	DESCRIPTION
7 (MSB)	ADEEM2	1	Activates the adaptive de-emphasis function, which is required for certain satellite FM channels. The standard FM de-emphasis must then be set to 75 $\mu$ s (note 2).
		0	The adaptive de-emphasis is off.
6	B6	–	Time constant selection for FM de-emphasis (see Table 26).
5	B5		
4	B4		
3	ADEEM1	1	Activates the adaptive de-emphasis function, which is required for certain satellite FM channels. The standard FM de-emphasis must then be set to 75 $\mu$ s (note 2).
		0	The adaptive de-emphasis is off.
2	B2	–	Time constant selection for FM de-emphasis (see Table 27).
1	B1		
0 (LSB)	B0		

**Note**

1. The default setting at power-up is 0000 0000.
2. The FM de-emphasis gain is 0 dB at 40 Hz.

**Table 26** De-emphasis sound carrier 2

B6	B5	B4	DE-EMPHASIS
0	0	0	50 $\mu$ s (Europe)
0	0	1	60 $\mu$ s
0	1	0	75 $\mu$ s (M standard)
0	1	1	J17
1	0	0	off

**Table 27** De-emphasis sound carrier 1

B2	B1	B0	DE-EMPHASIS
0	0	0	50 $\mu$ s (Europe)
0	0	1	60 $\mu$ s



## Digital TV Sound Processor (DTVSP)

## TDA9875A

B2	B1	B0	DE-EMPHASIS
0	1	0	75 $\mu$ s (M standard)
0	1	1	J17
1	0	0	off

## 10.3.8 FM MATRIX REGISTER

This register is used to select the proper dematrixing characteristics as appropriate for the standard of the received carrier and the related sound mode identification.

**Table 28** Subaddress 11 (note 1)

BIT	NAME	VALUE	DESCRIPTION
7 (MSB)	B7	0	default value
6	B6	0	default value
5	B5	0	default value
4	B4	0	default value
3	B3	0	default value
2	B2	–	dematrixing characteristics (see Table 29)
1	B1		
0 (LSB)	B0		

**Note**

- The default setting at power-up is 0000 0000.

**Table 29** Dematrixing characteristics

B2	B1	B0	L OUTPUT	R OUTPUT	MODE
0	0	0	CH1 input; note 1	CH1 input; note 1	mono 1
0	0	1	CH2 input; note 2	CH2 input; note 2	mono 2
0	1	0	CH1 input; note 1	CH2 input; note 2	dual
0	1	1	CH2 input; note 2	CH1 input; note 1	dual swapped
1	0	0	2CH1 input – CH2 input	CH2 input; note 2	stereo Europe
1	0	1	$\frac{\text{CH1 input} + \text{CH2 input}}{2}$	$\frac{\text{CH1 input} - \text{CH2 input}}{2}$	stereo Korea; note 3

**Notes**

- CH1 input: audio signal from FM channel 1.
- CH2 input: audio signal from FM channel 2.
- For stereo Korea the dematrix applies 6 dB attenuation (see Table 7).

## Digital TV Sound Processor (DTVSP)

## TDA9875A

## 10.3.9 FM CHANNEL 1 LEVEL ADJUST REGISTER

This register is used to correct for standard and station-dependent differences of signal levels.

Table 30 applies to sound carrier 1.

**Table 30** Subaddress 12

MSB				LSB				GAIN SETTING (dB)
B7	B6	B5	B4	B3	B2	B1	B0	
0	0	0	0	1	1	1	1	+15
0	0	0	0	1	1	1	0	+14
0	0	0	0	1	1	0	1	+13
0	0	0	0	1	1	0	0	+12
0	0	0	0	1	0	1	1	+11
0	0	0	0	1	0	1	0	+10
0	0	0	0	1	0	0	1	+9
0	0	0	0	1	0	0	0	+8
0	0	0	0	0	1	1	1	+7
0	0	0	0	0	1	1	0	+6
0	0	0	0	0	1	0	1	+5
0	0	0	0	0	1	0	0	+4
0	0	0	0	0	0	1	1	+3
0	0	0	0	0	0	1	0	+2
0	0	0	0	0	0	0	1	+1
0	0	0	0	0	0	0	0	0 (note 1)
0	0	0	1	1	1	1	1	-1
0	0	0	1	1	1	1	0	-2
0	0	0	1	1	1	0	1	-3
0	0	0	1	1	1	0	0	-4
0	0	0	1	1	0	1	1	-5
0	0	0	1	1	0	1	0	-6
0	0	0	1	1	0	0	1	-7
0	0	0	1	1	0	0	0	-8
0	0	0	1	0	1	1	1	-9
0	0	0	1	0	1	1	0	-10
0	0	0	1	0	1	0	1	-11
0	0	0	1	0	1	0	0	-12
0	0	0	1	0	0	1	1	-13
0	0	0	1	0	0	1	0	-14
0	0	0	1	0	0	0	1	-15
0	0	0	1	0	0	0	0	mute

**Note**

1. The default setting at power-up is 0000 0000.

## Digital TV Sound Processor (DTVSP)

## TDA9875A

## 10.3.10 FM CHANNEL 2 LEVEL ADJUST REGISTER

This register is used to correct for standard and station-dependent differences of signal levels. Table 31 applies to sound carrier 2 in its FM and AM modes. In the event of A2, channels 1 and 2 should be adjusted to the same level.

Table 31 Subaddress 13

MSB							LSB		GAIN SETTING (dB)
B7	B6	B5	B4	B3	B2	B1	B0		
0	0	0	0	1	1	1	1	+15	
0	0	0	0	1	1	1	0	+14	
0	0	0	0	1	1	0	1	+13	
0	0	0	0	1	1	0	0	+12	
0	0	0	0	1	0	1	1	+11	
0	0	0	0	1	0	1	0	+10	
0	0	0	0	1	0	0	1	+9	
0	0	0	0	1	0	0	0	+8	
0	0	0	0	0	1	1	1	+7	
0	0	0	0	0	1	1	0	+6	
0	0	0	0	0	1	0	1	+5	
0	0	0	0	0	1	0	0	+4	
0	0	0	0	0	0	1	1	+3	
0	0	0	0	0	0	1	0	+2	
0	0	0	0	0	0	0	1	+1	
0	0	0	0	0	0	0	0	0 (note 1)	
0	0	0	1	1	1	1	1	-1	
0	0	0	1	1	1	1	0	-2	
0	0	0	1	1	1	0	1	-3	
0	0	0	1	1	1	0	0	-4	
0	0	0	1	1	0	1	1	-5	
0	0	0	1	1	0	1	0	-6	
0	0	0	1	1	0	0	1	-7	
0	0	0	1	1	0	0	0	-8	
0	0	0	1	0	1	1	1	-9	
0	0	0	1	0	1	1	0	-10	
0	0	0	1	0	1	0	1	-11	
0	0	0	1	0	1	0	0	-12	
0	0	0	1	0	0	1	1	-13	
0	0	0	1	0	0	1	0	-14	
0	0	0	1	0	0	0	1	-15	
0	0	0	1	0	0	0	0	mute	

**Note**

1. The default setting at power-up is 0000 0000.

## Digital TV Sound Processor (DTVSP)

## TDA9875A

## 10.3.11 NICAM CONFIGURATION REGISTER

The decision of whether auto-muting is permitted shall be taken by the controlling microcontroller based on information contained in the TDA9875A's status registers. Thus, it depends on the strategy implemented in the software whether the auto-mute function is in accordance with "NICAM 728 ETS Revised for Data Applications" or any other preference.

The NICAM de-emphasis gain is 0 dB at 40 Hz.

**Table 32** Subaddress 14 (note 1)

BIT	NAME	VALUE	DESCRIPTION
7 (MSB)	DCXOPULL	1	Set to lower DCXO frequency during DCXO test mode.
		0	Set to higher DCXO frequency during DCXO test mode.
6	DCXOTEST	1	DCXO test mode on (available only during FM mode); note 2
		0	DCXO normal mode on
5	B5	0	Set logic to 0.
4	DOUTEN	1	Enables the output of the NICAM serial data stream from the DQPSK demodulator on pin NICAM and of the associated clock on pin PCLK
		0	Both outputs will be 3-stated.
3		0	Set logic to 0.
2	AMSEL	1	The auto-mute function will switch the output sound from NICAM L to the ADC output select register. With the ADC output select register the wanted signal source, e.g. the mono input, can be pre-set (see Section 10.3.20). This is useful, if the AM sound NICAM L system is demodulated externally.
		0	The auto-mute function will switch the output sound from NICAM L to the AM program on the internal first sound carrier.
1	NDEEM	1	Switches the NICAM J17 de-emphasis off.
		0	Switches the NICAM J17 de-emphasis on.
0 (LSB)	AMUTE	1	Automatic muting is disabled. This bit has only an effect when the second sound carrier is set to NICAM.
		0	Enables the automatic switching between NICAM and the program on the first sound carrier (i.e. FM mono or AM), dependent on the NICAM bit error rate.

### Notes

1. The default setting at power-up is 0000 0000.
2. The DCXO test mode is intended for checking the DCXO control range with the actually used PCB layout and crystal type. During the normal operating mode, the DCXO test mode should not be used.

## Digital TV Sound Processor (DTVSP)

## TDA9875A

## 10.3.12 NICAM LEVEL ADJUST REGISTER

This register is used to correct for standard and station-dependent differences of signal levels.

Table 33 applies to both NICAM sound outputs.

**Table 33** Subaddress 15 (note 1)

MSB							LSB		GAIN SETTING (dB)
B7	B6	B5	B4	B3	B2	B1	B0		
0	0	0	0	1	1	1	1	+15	
0	0	0	0	1	1	1	0	+14	
0	0	0	0	1	1	0	1	+13	
0	0	0	0	1	1	0	0	+12	
0	0	0	0	1	0	1	1	+11	
0	0	0	0	1	0	1	0	+10	
0	0	0	0	1	0	0	1	+9	
0	0	0	0	1	0	0	0	+8	
0	0	0	0	0	1	1	1	+7	
0	0	0	0	0	1	1	0	+6	
0	0	0	0	0	1	0	1	+5	
0	0	0	0	0	1	0	0	+4	
0	0	0	0	0	0	1	1	+3	
0	0	0	0	0	0	1	0	+2	
0	0	0	0	0	0	0	1	+1	
0	0	0	0	0	0	0	0	0 (note 1)	
0	0	0	1	1	1	1	1	-1	
0	0	0	1	1	1	1	0	-2	
0	0	0	1	1	1	0	1	-3	
0	0	0	1	1	1	0	0	-4	
0	0	0	1	1	0	1	1	-5	
0	0	0	1	1	0	1	0	-6	
0	0	0	1	1	0	0	1	-7	
0	0	0	1	1	0	0	0	-8	
0	0	0	1	0	1	1	1	-9	
0	0	0	1	0	1	1	0	-10	
0	0	0	1	0	1	0	1	-11	
0	0	0	1	0	1	0	0	-12	
0	0	0	1	0	0	1	1	-13	
0	0	0	1	0	0	1	0	-14	
0	0	0	1	0	0	0	1	-15	
0	0	0	1	0	0	0	0	mute	

**Note**

1. The default setting at power-up is 000 00000.

## Digital TV Sound Processor (DTVSP)

## TDA9875A

## 10.3.13 NICAM LOWER ERROR LIMIT REGISTER

When the auto-mute function is enabled (bit AMUTE in the NICAM configuration register) and the NICAM bit error count is lower than the value contained in this register, the NICAM signal is selected (again) for reproduction (see Section 10.3.14).

**Table 34** Subaddress 16 (notes 1 and 2)

BIT	NAME	VALUE	DESCRIPTION
7 (MSB)	B7	–	lower error limit value
6	B6		
5	B5		
4	B4		
3	B3		
2	B2		
1	B1		
0 (LSB)	B0		

**Notes**

1. The default setting at power-up is 0001 0100.
2. The lower bit error rate  
limit  $\cong$  subaddress 16  $\times$  1.74  $\times$  10<sup>-5</sup>.

## 10.3.14 NICAM UPPER ERROR LIMIT REGISTER

When the auto-mute function is enabled (bit AMUTE in the NICAM configuration register) and the NICAM bit error count is higher than the value contained in this register, the signal of the first sound carrier (i.e. FM mono or AM sound) or the external mono input (depending on bit AMSEL and ADC output selection) is selected for reproduction.

The difference between upper and lower error limit constitutes a hysteresis to avoid frequent switching between NICAM and the program on the first sound carrier.

**Table 35** Subaddress 17 (notes 1 and 2)

BIT	NAME	VALUE	DESCRIPTION
7 (MSB)	B7	–	upper error limit value
6	B6		
5	B5		
4	B4		
3	B3		
2	B2		
1	B1		
0 (LSB)	B0		

**Notes**

1. The default setting at power-up is 0101 0000.
2. The upper bit error rate  
limit  $\cong$  subaddress 17  $\times$  1.74  $\times$  10<sup>-5</sup>.

## Digital TV Sound Processor (DTVSP)

## TDA9875A

## 10.3.15 AUDIO MUTE CONTROL REGISTER

When any of these bits are set to logic 1, the corresponding pair of output channels will be muted. A bit set to logic 0 allows normal signal output.

There is a soft mute facility for the Main and Auxiliary output channels to provide click-free muting independent of the volume control. This is switched on/off by bits MUTMAIN and MUTAUX.

**Table 36** Subaddress 18 (note 1)

BIT	NAME	VALUE	DESCRIPTION
7 (MSB)	MUTI <sup>2</sup> S2	1	mute I <sup>2</sup> S2 output
		0	normal I <sup>2</sup> S2 output
6	MUTI <sup>2</sup> S1	1	mute I <sup>2</sup> S1 output
		0	normal I <sup>2</sup> S1 output
5	MUTDAC	1	mute internal DAC
		0	normal internal DAC
4	MUTLINE	1	mute line outputs
		0	normal line outputs
3	MUTSC2	1	mute SCART 2 outputs
		0	normal SCART 2 outputs
2	MUTSC1	1	mute SCART 1 outputs
		0	normal SCART 1 outputs
1	MUTAUX	1	mute Auxiliary outputs
		0	normal Auxiliary outputs
0 (LSB)	MUTMAIN	1	mute Main outputs
		0	normal Main outputs

**Note**

1. The default setting at power-up is 1111 1111.

## 10.3.16 DAC OUTPUT SELECT REGISTER

This register is used to define both the signal source to be entered into the DAC and the mode of the digital matrix for signal selection. The DAC is used for signal output from digital sources at analog outputs.

The bits DACGAIN1 and DACGAIN2 can introduce some extra gain at the input to the DAC; DACGAIN1 adds 3 dB and DACGAIN2 adds 6 dB of gain, respectively.

The two combinations of FM and NICAM apply to the (rare) condition that three different languages are being broadcast in an FM + NICAM system. They allow for a two-out-of-three selection for external use, such as recording.

## Digital TV Sound Processor (DTVSP)

## TDA9875A

**Table 37** Subaddress 19 (note 1)

BIT	NAME	VALUE	DESCRIPTION
7 (MSB)	DACGAIN2	–	extra gain setting (see Table 38)
6	B6	–	DAC output selection (see Table 39)
5	B5		
4	B4		
3	DACGAIN1	–	extra gain setting (see Table 38)
2	B2	–	signal source selection (see Table 40)
1	B1		
0 (LSB)	B0		

**Note**

1. The default setting at power-up is 0000 0000.

**Table 38** Extra gain setting

B7	B3	GAIN (dB)
0	0	0
0	1	3
1	0	6
1	1	9

**Table 39** DAC output selection

B6	B5	B4	L OUTPUT	R OUTPUT
0	0	0	L input	R input
0	0	1	L input	L input
0	1	0	R input	R input
0	1	1	R input	L input
1	0	0	$\frac{L + R}{2}$	$\frac{L + R}{2}$

**Table 40** Signal source selection

B2	B1	B0	SIGNAL SOURCE	
			LEFT	RIGHT
0	0	0	FM left	FM right
0	0	1	NICAM left	NICAM right
0	1	0	I <sup>2</sup> S1 left	I <sup>2</sup> S1 right
0	1	1	I <sup>2</sup> S2 left	I <sup>2</sup> S2 right
1	0	0	ADC left	ADC right
1	0	1	AVL left	AVL right
1	1	0	FM mono	NICAM M1
1	1	1	FM mono	NICAM M2



## Digital TV Sound Processor (DTVSP)

## TDA9875A

## 10.3.17 SCART 1 OUTPUT SELECT REGISTER

This register is used to define both the signal source to be output at SCART 1 and the output channel selector mode.

**Table 41** Subaddress 20 (note 1)

BIT	NAME	VALUE	DESCRIPTION
7 (MSB)	B7	0	default value
6	SC1GAIN	1	Activates the 3 dB gain stage at the SCART 1 output buffers. As any SCART input passes a 3 dB attenuator, this gain stage can be used to compensate that attenuation, resulting in a 0 dB insertion loss when copying from SCART 2 input to SCART 1 output. However, that gain must be used with great care, as it will cause signal clipping at high input levels.
		0	the audio signal output will be unchanged (0 dB gain)
5	B5	–	output channel selection (see Table 42)
4	B4		
3	B3	0	default value
2	B2	–	signal source selection (see Table 43)
1	B1		
0 (LSB)	B0		

**Note**

- The default setting at power-up is 0000 0001.

**Table 42** Output channel selection

B5	B4	L OUTPUT	R OUTPUT
0	0	L input	R input
0	1	L input	L input
1	0	R input	R input
1	1	R input	L input

**Table 43** Signal source selection

B2	B1	B0	SIGNAL SOURCE
0	0	0	SCART 1 input
0	0	1	SCART 2 input
0	1	0	external input
0	1	1	mono input
1	0	0	DAC input

## Digital TV Sound Processor (DTVSP)

## TDA9875A

## 10.3.18 SCART 2 OUTPUT SELECT REGISTER

This register is used to define both the signal source to be output at SCART 2 and the output channel selector mode.

**Table 44** Subaddress 21 (note 1)

BIT	NAME	VALUE	DESCRIPTION
7 (MSB)	B7	0	
6	SC2GAIN	1	Activates the 3 dB gain stage at the SCART 2 output buffers. As any SCART input passes a 3 dB attenuator, this gain stage can be used to compensate that attenuation, resulting in a 0 dB insertion loss when copying from SCART 1 input to SCART 2 output. However, that gain must be used with great care, as it will cause signal clipping at high input levels.
		0	the audio signal output will be output (0 dB gain)
5	B5	–	output channel selection (see Table 45)
4	B4		
3	B3	0	default value
2	B2	–	signal source selection (see Table 46)
1	B1		
0 (LSB)	B0		

**Note**

- The default setting at power-up is 0000 0000.

**Table 45** Output channel selection

B5	B4	L OUTPUT	R OUTPUT
0	0	L input	R input
0	1	L input	L input
1	0	R input	R input
1	1	R input	L input

**Table 46** Signal source selection

B2	B1	B0	SIGNAL SOURCE
0	0	0	SCART 1 input
0	0	1	SCART 2 input
0	1	0	external input
0	1	1	mono input
1	0	0	DAC input

## Digital TV Sound Processor (DTVSP)

## TDA9875A

## 10.3.19 LINE OUTPUT SELECT REGISTER

By definition, the line output conveys the same signal as the Main (loudspeaker) channel, but in a non-processed form. This register is used to characterize the signal to be output at the line output and define the output channel selector mode.

**Table 47** Subaddress 22 (note 1)

BIT	NAME	VALUE	DESCRIPTION
7 (MSB)	B7	0	set to logic 0
6	LINGAIN	1	activates the 3 dB gain stage at the line output buffers
		0	audio signal will be output unchanged (0 dB gain)
5	B5	–	output channel selection (see Table 48)
4	B4		
3	B3	0	set to logic 0
2	B2	0	set to logic 0
1	B1	0	set to logic 0
0 (LSB)	LINSEL	1	A signal from an analog source is being processed in the Main channel for line output. Analog signal sources comprise SCART 1 input, SCART 2 input, external input and mono input, i.e. any input to the ADC.
		0	A signal from a digital source is being processed in the Main channel for line output. Digital signal sources comprise FM, NICAM, I <sup>2</sup> S1 input and I <sup>2</sup> S2 input.

**Note**

1. The default setting at power-up is 0000 0000.

**Table 48** Output channel selection

B5	B4	L OUTPUT	R OUTPUT
0	0	L input	R input
0	1	L input	L input
1	0	R input	R input
1	1	R input	L input

## Digital TV Sound Processor (DTVSP)

## TDA9875A

## 10.3.20 ADC OUTPUT SELECT REGISTER

This register is used to define the signal source for the ADC. There is no output channel selector, because all digital signal sinks of the ADC have their own matrix. Instead, a level adjustment facility for the ADC output is provided.

**Table 49** Subaddress 23 (note 1)

BIT	NAME	VALUE	DESCRIPTION
7 (MSB)	B7	–	signal source selection (see Table 50)
6	B6		
5	B5		
4	B4	–	ADC level adjust (see Table 51)
3	B3		
2	B2		
1	B1		
0 (LSB)	B0		

**Note**

1. The default setting at power-up is 0000 0000.

**Table 50** Signal source selection

B7	B6	B5	SIGNAL SOURCE
0	0	0	SCART 1 input
0	0	1	SCART 2 input
0	1	0	external input
0	1	1	mono input

## Digital TV Sound Processor (DTVSP)

## TDA9875A

**Table 51** ADC level adjust (note 1)

B4	B3	B2	B1	B0	GAIN SETTING (dB)
0	1	1	1	1	+15
0	1	1	1	0	+14
0	1	1	0	1	+13
0	1	1	0	0	+12
0	1	0	1	1	+11
0	1	0	1	0	+10
0	1	0	0	1	+9
0	1	0	0	0	+8
0	0	1	1	1	+7
0	0	1	1	0	+6
0	0	1	0	1	+5
0	0	1	0	0	+4
0	0	0	1	1	+3
0	0	0	1	0	+2
0	0	0	0	1	+1
0	0	0	0	0	0
1	1	1	1	1	-1
1	1	1	1	0	-2
1	1	1	0	1	-3
1	1	1	0	0	-4
1	1	0	1	1	-5
1	1	0	1	0	-6
1	1	0	0	1	-7
1	1	0	0	0	-8
1	0	1	1	1	-9
1	0	1	1	0	-10
1	0	1	0	1	-11
1	0	1	0	0	-12
1	0	0	1	1	-13
1	0	0	1	0	-14
1	0	0	0	1	-15
1	0	0	0	0	mute

**Note**

1. If the ADC level adjust is set to 0 dB a full-scale input signal to the ADC results into a full-scale level of -6 dB at the digital crossbar.

## Digital TV Sound Processor (DTVSP)

## TDA9875A

## 10.3.21 MAIN CHANNEL SELECT REGISTER

This register is used to define both the signal source to be processed in the Main (loudspeaker) channel and the mode of the digital matrix for signal selection.

**Table 52** Subaddress 24 (note 1)

BIT	NAME	VALUE	DESCRIPTION
7 (MSB)	B7	0	default value
6	B6	–	output channel selection (see Table 53)
5	B5		
4	B4		
3	B3	0	default value
2	B2	–	signal source selection (see Table 54)
1	B1		
0 (LSB)	B0		

**Note**

1. The default setting at power-up is 0000 0000.

**Table 53** Output channel selection

B6	B5	B4	L OUTPUT	R OUTPUT
0	0	0	L input	R input
0	0	1	L input	L input
0	1	0	R input	R input
0	1	1	R input	L input
1	0	0	$\frac{L+R}{2}$	$\frac{L+R}{2}$

**Table 54** Signal source selection

B2	B1	B0	SIGNAL SOURCE
0	0	0	FM input
0	0	1	NICAM input
0	1	0	I <sup>2</sup> S1 input
0	1	1	I <sup>2</sup> S2 input
1	0	0	ADC input

## Digital TV Sound Processor (DTVSP)

## TDA9875A

## 10.3.22 AUDIO EFFECTS REGISTER (MAIN)

Switching the AVL off will reset the associated hardware to a defined state. When the signal source for the Main channel is changed while the AVL is on, the AVL needs to be reset in order to avoid excessive settling times. This can be achieved by switching the AVL off and on again.

The pseudo stereo function is based on an all-pass filter. A 90 degrees phase shift occurs at the frequencies stated in Table 57. There is a gain of 3 dB in the left audio channel.

**Table 55** Subaddress 25 (note 1)

BIT	NAME	VALUE	DESCRIPTION
7 (MSB)	B7	0	Default value.
6	B6	0	Default value.
5	SPATIAL1	–	These bits set the amount of the effect function (stereo base width expansion) for stereo signals in the Main channel (see Table 56). This function should be activated only in accordance with the result of the sound mode identification.
4	SPATIAL0		
3	PSEUDO1	–	These bits set the amount of the effect function (pseudo stereo) for mono signals in the Main channel (see Table 57). This function should be activated only in accordance with the result of the sound mode identification.
2	PSEUDO0		
1	AVL1	–	These bits set the mode of operation of the automatic volume level control function at the entrance to the Main (loudspeaker) channel (see Table 58).
0 (LSB)	AVL0		

**Note**

1. The default setting at power-up is 0000 0000.

**Table 56** Spatial control setting

B5	B4	SPATIAL SETTING (%)
0	0	off
0	1	30
1	0	40
1	1	52

**Table 57** Pseudo control setting

B3	B2	PSEUDO SETTING (Hz)
0	0	off
0	1	300
1	0	200
1	1	150

**Table 58** AVL control mode

B1	B0	AVL MODE
0	0	off/reset
0	1	short decay
1	0	medium decay
1	1	long decay

## Digital TV Sound Processor (DTVSP)

## TDA9875A

## 10.3.23 VOLUME CONTROL REGISTERS (MAIN)

These two registers control the volume setting of the Main (loudspeaker) channel. The register at subaddress 26 applies to the left channel signal, while the register at subaddress 27 applies to the right channel signal.

Balance control is exercised by offsetting the left and right channel volume settings.

**Table 59** Subaddresses 26 and 27

MSB							LSB		VOLUME SETTING (dB)
B7	B6	B5	B4	B3	B2	B1	B0		
0	0	0	1	1	0	0	0	+24	
0	0	0	1	0	1	1	1	+23	
0	0	0	1	0	1	1	0	+22	
0	0	0	1	0	1	0	1	+21	
0	0	0	1	0	1	0	0	+20	
0	0	0	1	0	0	1	1	+19	
0	0	0	1	0	0	1	0	+18	
0	0	0	1	0	0	0	1	+17	
0	0	0	1	0	0	0	0	+16	
0	0	0	0	1	1	1	1	+15	
0	0	0	0	1	1	1	0	+14	
0	0	0	0	1	1	0	1	+13	
0	0	0	0	1	1	0	0	+12	
0	0	0	0	1	0	1	1	+11	
0	0	0	0	1	0	1	0	+10	
0	0	0	0	1	0	0	1	+9	
0	0	0	0	1	0	0	0	+8	
0	0	0	0	0	1	1	1	+7	
0	0	0	0	0	1	1	0	+6	
0	0	0	0	0	1	0	1	+5	
0	0	0	0	0	1	0	0	+4	
0	0	0	0	0	0	1	1	+3	
0	0	0	0	0	0	1	0	+2	
0	0	0	0	0	0	0	1	+1	
0	0	0	0	0	0	0	0	0	
1	1	1	1	1	1	1	1	-1	
1	1	1	1	1	1	1	0	-2	
1	1	1	1	1	1	0	1	-3	
1	1	1	1	1	1	0	0	-4	
1	1	1	1	1	0	1	1	-5	
1	1	1	1	1	0	1	0	-6	
1	1	1	1	1	0	0	1	-7	
1	1	1	1	1	0	0	0	-8	
1	1	1	1	0	1	1	1	-9	



## Digital TV Sound Processor (DTVSP)

## TDA9875A

MSB							LSB		VOLUME SETTING (dB)
B7	B6	B5	B4	B3	B2	B1	B0		
1	1	1	1	0	1	1	0	-10	
1	1	1	1	0	1	0	1	-11	
1	1	1	1	0	1	0	0	-12	
1	1	1	1	0	0	1	1	-13	
1	1	1	1	0	0	1	0	-14	
1	1	1	1	0	0	0	1	-15	
1	1	1	1	0	0	0	0	-16	
1	1	1	0	1	1	1	1	-17	
1	1	1	0	1	1	1	0	-18	
1	1	1	0	1	1	0	1	-19	
1	1	1	0	1	1	0	0	-20	
1	1	1	0	1	0	1	1	-21	
1	1	1	0	1	0	1	0	-22	
1	1	1	0	1	0	0	1	-23	
1	1	1	0	1	0	0	0	-24	
1	1	1	0	0	1	1	1	-25	
1	1	1	0	0	1	1	0	-26	
1	1	1	0	0	1	0	1	-27	
1	1	1	0	0	1	0	0	-28	
1	1	1	0	0	0	1	1	-29	
1	1	1	0	0	0	1	0	-30	
1	1	1	0	0	0	0	1	-31	
1	1	1	0	0	0	0	0	-32	
1	1	0	1	1	1	1	1	-33	
1	1	0	1	1	1	1	0	-34	
1	1	0	1	1	1	0	1	-35	
1	1	0	1	1	1	0	0	-36	
1	1	0	1	1	0	1	1	-37	
1	1	0	1	1	0	1	0	-38	
1	1	0	1	1	0	0	1	-39	
1	1	0	1	1	0	0	0	-40	
1	1	0	1	0	1	1	1	-41	
1	1	0	1	0	1	1	0	-42	
1	1	0	1	0	1	0	1	-43	
1	1	0	1	0	1	0	0	-44	
1	1	0	1	0	0	1	1	-45	
1	1	0	1	0	0	1	0	-46	
1	1	0	1	0	0	0	1	-47	
1	1	0	1	0	0	0	0	-48	

## Digital TV Sound Processor (DTVSP)

## TDA9875A

MSB							LSB		VOLUME SETTING (dB)
B7	B6	B5	B4	B3	B2	B1	B0		
1	1	0	0	1	1	1	1	-49	
1	1	0	0	1	1	1	0	-50	
1	1	0	0	1	1	0	1	-51	
1	1	0	0	1	1	0	0	-52	
1	1	0	0	1	0	1	1	-53	
1	1	0	0	1	0	1	0	-54	
1	1	0	0	1	0	0	1	-55	
1	1	0	0	1	0	0	0	-56	
1	1	0	0	0	1	1	1	-57	
1	1	0	0	0	1	1	0	-58	
1	1	0	0	0	1	0	1	-59	
1	1	0	0	0	1	0	0	-60	
1	1	0	0	0	0	1	1	-61	
1	1	0	0	0	0	1	0	-62	
1	1	0	0	0	0	0	1	-63	
1	1	0	0	0	0	0	0	-64	
1	0	1	1	1	1	1	1	-65	
1	0	1	1	1	1	1	0	-66	
1	0	1	1	1	1	0	1	-67	
1	0	1	1	1	1	0	0	-68	
1	0	1	1	1	0	1	1	-69	
1	0	1	1	1	0	1	0	-70	
1	0	1	1	1	0	0	1	-71	
1	0	1	1	1	0	0	0	-72	
1	0	1	1	0	1	1	1	-73	
1	0	1	1	0	1	1	0	-74	
1	0	1	1	0	1	0	1	-75	
1	0	1	1	0	1	0	0	-76	
1	0	1	1	0	0	1	1	-77	
1	0	1	1	0	0	1	0	-78	
1	0	1	1	0	0	0	1	-79	
1	0	1	1	0	0	0	0	-80	
1	0	1	0	1	1	1	1	-81	
1	0	1	0	1	1	1	0	-82	
1	0	1	0	1	1	0	1	-83	
1	0	1	0	1	1	0	0	mute (note 1)	

**Note**

1. The default setting at power-up is 1010 1100.

## Digital TV Sound Processor (DTVSP)

## TDA9875A

## 10.3.24 CONTOUR CONTROL REGISTER (MAIN)

This register is used to apply the contour or loudness function (physiological volume control) to the left and right signal channels of the Main channel by means of an extra bass boost. The gain setting must be chosen in accordance with the volume control setting for the Main channel. For example, the contour gain could be incremented for every 5 dB, or so, of decrease of the volume setting. This needs to be done by the microcontroller. The 0 dB contour setting is equal to contour off.

Table 60 Subaddress 28

MSB							LSB		CONTOUR GAIN (dB)
B7	B6	B5	B4	B3	B2	B1	B0		
0	0	0	1	0	0	1	0	18	
0	0	0	1	0	0	0	1	17	
0	0	0	1	0	0	0	0	16	
0	0	0	0	1	1	1	1	15	
0	0	0	0	1	1	1	0	14	
0	0	0	0	1	1	0	1	13	
0	0	0	0	1	1	0	0	12	
0	0	0	0	1	0	1	1	11	
0	0	0	0	1	0	1	0	10	
0	0	0	0	1	0	0	1	9	
0	0	0	0	1	0	0	0	8	
0	0	0	0	0	1	1	1	7	
0	0	0	0	0	1	1	0	6	
0	0	0	0	0	1	0	1	5	
0	0	0	0	0	1	0	0	4	
0	0	0	0	0	0	1	1	3	
0	0	0	0	0	0	1	0	2	
0	0	0	0	0	0	0	1	1	
0	0	0	0	0	0	0	0	0 (note 1)	

**Note**

1. The default setting at power-up is 0000 0000.

## Digital TV Sound Processor (DTVSP)

## TDA9875A

## 10.3.25 BASS CONTROL REGISTER (MAIN)

This register is used to apply bass control to the left and right signal channels of the Main channel.

Table 61 Subaddress 29

MSB				LSB				BASS SETTING (dB)
B7	B6	B5	B4	B3	B2	B1	B0	
0	0	0	0	1	1	1	1	+15
0	0	0	0	1	1	1	0	+14
0	0	0	0	1	1	0	1	+13
0	0	0	0	1	1	0	0	+12
0	0	0	0	1	0	1	1	+11
0	0	0	0	1	0	1	0	+10
0	0	0	0	1	0	0	1	+9
0	0	0	0	1	0	0	0	+8
0	0	0	0	0	1	1	1	+7
0	0	0	0	0	1	1	0	+6
0	0	0	0	0	1	0	1	+5
0	0	0	0	0	1	0	0	+4
0	0	0	0	0	0	1	1	+3
0	0	0	0	0	0	1	0	+2
0	0	0	0	0	0	0	1	+1
0	0	0	0	0	0	0	0	0 (note 1)
0	0	0	1	1	1	1	1	-1
0	0	0	1	1	1	1	0	-2
0	0	0	1	1	1	0	1	-3
0	0	0	1	1	1	0	0	-4
0	0	0	1	1	0	1	1	-5
0	0	0	1	1	0	1	0	-6
0	0	0	1	1	0	0	1	-7
0	0	0	1	1	0	0	0	-8
0	0	0	1	0	1	1	1	-9
0	0	0	1	0	1	1	0	-10
0	0	0	1	0	1	0	1	-11
0	0	0	1	0	1	0	0	-12

**Note**

1. The default setting at power-up is 0000 0000.

## Digital TV Sound Processor (DTVSP)

## TDA9875A

## 10.3.26 TREBLE CONTROL REGISTER (MAIN)

This register is used to apply treble control to the left and right signal channels of the Main channel.

**Table 62** Subaddress 30

MSB							LSB		TREBLE SETTING (dB)
B7	B6	B5	B4	B3	B2	B1	B0		
0	0	0	0	1	1	0	0	+12	
0	0	0	0	1	0	1	1	+11	
0	0	0	0	1	0	1	0	+10	
0	0	0	0	1	0	0	1	+9	
0	0	0	0	1	0	0	0	+8	
0	0	0	0	0	1	1	1	+7	
0	0	0	0	0	1	1	0	+6	
0	0	0	0	0	1	0	1	+5	
0	0	0	0	0	1	0	0	+4	
0	0	0	0	0	0	1	1	+3	
0	0	0	0	0	0	1	0	+2	
0	0	0	0	0	0	0	1	+1	
0	0	0	0	0	0	0	0	0 (note 1)	
0	0	0	1	1	1	1	1	-1	
0	0	0	1	1	1	1	0	-2	
0	0	0	1	1	1	0	1	-3	
0	0	0	1	1	1	0	0	-4	
0	0	0	1	1	0	1	1	-5	
0	0	0	1	1	0	1	0	-6	
0	0	0	1	1	0	0	1	-7	
0	0	0	1	1	0	0	0	-8	
0	0	0	1	0	1	1	1	-9	
0	0	0	1	0	1	1	0	-10	
0	0	0	1	0	1	0	1	-11	
0	0	0	1	0	1	0	0	-12	

**Note**

1. The default setting at power-up is 0000 0000.

## Digital TV Sound Processor (DTVSP)

## TDA9875A

## 10.3.27 AUXILIARY CHANNEL SELECT REGISTER

This register is used to define both the signal source to be processed in the Auxiliary (headphone) channel and the mode of the digital matrix for signal selection.

**Table 63** Subaddress 31 (note 1)

BIT	NAME	VALUE	DESCRIPTION
7 (MSB)	B7	0	default value
6	B6	–	output channel selection (see Table 64)
5	B5		
4	B4		
3	B3	0	default value
2	B2	–	signal source selection (see Table 65)
1	B1		
0 (LSB)	B0		

**Note**

1. The default setting at power-up is 0000 0000.

**Table 64** Output channel selection

B6	B5	B4	L OUTPUT	R OUTPUT
0	0	0	L input	R input
0	0	1	L input	L input
0	1	0	R input	R input
0	1	1	R input	L input
1	0	0	$\frac{L+R}{2}$	$\frac{L+R}{2}$

**Table 65** Signal source selection

B2	B1	B0	SIGNAL SOURCE
0	0	0	FM input
0	0	1	NICAM input
0	1	0	I <sup>2</sup> S1 input
0	1	1	I <sup>2</sup> S2 input
1	0	0	ADC input
1	0	1	AVL input

## Digital TV Sound Processor (DTVSP)

## TDA9875A

## 10.3.28 VOLUME CONTROL REGISTERS (AUXILIARY)

These two registers control the volume setting of the Auxiliary (headphone) channel. The register at subaddress 32 applies to the left channel signal, while the register at subaddress 33 applies to the right channel signal.

Balance control is exercised by offsetting the left and right channel volume settings.

**Table 66** Subaddresses 32 and 33

MSB				LSB				VOLUME SETTING (dB)
B7	B6	B5	B4	B3	B2	B1	B0	
0	0	0	1	1	0	0	0	+24
0	0	0	1	0	1	1	1	+23
0	0	0	1	0	1	1	0	+22
0	0	0	1	0	1	0	1	+21
0	0	0	1	0	1	0	0	+20
0	0	0	1	0	0	1	1	+19
0	0	0	1	0	0	1	0	+18
0	0	0	1	0	0	0	1	+17
0	0	0	1	0	0	0	0	+16
0	0	0	0	1	1	1	1	+15
0	0	0	0	1	1	1	0	+14
0	0	0	0	1	1	0	1	+13
0	0	0	0	1	1	0	0	+12
0	0	0	0	1	0	1	1	+11
0	0	0	0	1	0	1	0	+10
0	0	0	0	1	0	0	1	+9
0	0	0	0	1	0	0	0	+8
0	0	0	0	0	1	1	1	+7
0	0	0	0	0	1	1	0	+6
0	0	0	0	0	1	0	1	+5
0	0	0	0	0	1	0	0	+4
0	0	0	0	0	0	1	1	+3
0	0	0	0	0	0	1	0	+2
0	0	0	0	0	0	0	1	+1
0	0	0	0	0	0	0	0	0
1	1	1	1	1	1	1	1	-1
1	1	1	1	1	1	1	0	-2
1	1	1	1	1	1	0	1	-3
1	1	1	1	1	1	0	0	-4
1	1	1	1	1	0	1	1	-5
1	1	1	1	1	0	1	0	-6
1	1	1	1	1	0	0	1	-7
1	1	1	1	1	0	0	0	-8
1	1	1	1	0	1	1	1	-9
1	1	1	1	0	1	1	0	-10

## Digital TV Sound Processor (DTVSP)

## TDA9875A

MSB							LSB		VOLUME SETTING (dB)
B7	B6	B5	B4	B3	B2	B1	B0		
1	1	1	1	0	1	0	1	-11	
1	1	1	1	0	1	0	0	-12	
1	1	1	1	0	0	1	1	-13	
1	1	1	1	0	0	1	0	-14	
1	1	1	1	0	0	0	1	-15	
1	1	1	1	0	0	0	0	-16	
1	1	1	0	1	1	1	1	-17	
1	1	1	0	1	1	1	0	-18	
1	1	1	0	1	1	0	1	-19	
1	1	1	0	1	1	0	0	-20	
1	1	1	0	1	0	1	1	-21	
1	1	1	0	1	0	1	0	-22	
1	1	1	0	1	0	0	1	-23	
1	1	1	0	1	0	0	0	-24	
1	1	1	0	0	1	1	1	-25	
1	1	1	0	0	1	1	0	-26	
1	1	1	0	0	1	0	1	-27	
1	1	1	0	0	1	0	0	-28	
1	1	1	0	0	0	1	1	-29	
1	1	1	0	0	0	1	0	-30	
1	1	1	0	0	0	0	1	-31	
1	1	1	0	0	0	0	0	-32	
1	1	0	1	1	1	1	1	-33	
1	1	0	1	1	1	1	0	-34	
1	1	0	1	1	1	0	1	-35	
1	1	0	1	1	1	0	0	-36	
1	1	0	1	1	0	1	1	-37	
1	1	0	1	1	0	1	0	-38	
1	1	0	1	1	0	0	1	-39	
1	1	0	1	1	0	0	0	-40	
1	1	0	1	0	1	1	1	-41	
1	1	0	1	0	1	1	0	-42	
1	1	0	1	0	1	0	1	-43	
1	1	0	1	0	1	0	0	-44	
1	1	0	1	0	0	1	1	-45	
1	1	0	1	0	0	1	0	-46	
1	1	0	1	0	0	0	1	-47	
1	1	0	1	0	0	0	0	-48	
1	1	0	0	1	1	1	1	-49	
1	1	0	0	1	1	1	0	-50	
1	1	0	0	1	1	0	1	-51	



## Digital TV Sound Processor (DTVSP)

## TDA9875A

MSB							LSB		VOLUME SETTING (dB)
B7	B6	B5	B4	B3	B2	B1	B0		
1	1	0	0	1	1	0	0	-52	
1	1	0	0	1	0	1	1	-53	
1	1	0	0	1	0	1	0	-54	
1	1	0	0	1	0	0	1	-55	
1	1	0	0	1	0	0	0	-56	
1	1	0	0	0	1	1	1	-57	
1	1	0	0	0	1	1	0	-58	
1	1	0	0	0	1	0	1	-59	
1	1	0	0	0	1	0	0	-60	
1	1	0	0	0	0	1	1	-61	
1	1	0	0	0	0	1	0	-62	
1	1	0	0	0	0	0	1	-63	
1	1	0	0	0	0	0	0	-64	
1	0	1	1	1	1	1	1	-65	
1	0	1	1	1	1	1	0	-66	
1	0	1	1	1	1	0	1	-67	
1	0	1	1	1	1	0	0	-68	
1	0	1	1	1	0	1	1	-69	
1	0	1	1	1	0	1	0	-70	
1	0	1	1	1	0	0	1	-71	
1	0	1	1	1	0	0	0	-72	
1	0	1	1	0	1	1	1	-73	
1	0	1	1	0	1	1	0	-74	
1	0	1	1	0	1	0	1	-75	
1	0	1	1	0	1	0	0	-76	
1	0	1	1	0	0	1	1	-77	
1	0	1	1	0	0	1	0	-78	
1	0	1	1	0	0	0	1	-79	
1	0	1	1	0	0	0	0	-80	
1	0	1	0	1	1	1	1	-81	
1	0	1	0	1	1	1	0	-82	
1	0	1	0	1	1	0	1	-83	
1	0	1	0	1	1	0	0	mute (note 1)	

**Note**

1. The default setting at power-up is 1010 1100.

## Digital TV Sound Processor (DTVSP)

## TDA9875A

## 10.3.29 BASS CONTROL REGISTER (AUXILIARY)

This register is used to apply bass control to the left and right signal channels of the Auxiliary channel.

Table 67 Subaddress 34

MSB							LSB		BASS SETTING (dB)
B7	B6	B5	B4	B3	B2	B1	B0		
0	0	0	0	1	1	1	1	+15	
0	0	0	0	1	1	1	0	+14	
0	0	0	0	1	1	0	1	+13	
0	0	0	0	1	1	0	0	+12	
0	0	0	0	1	0	1	1	+11	
0	0	0	0	1	0	1	0	+10	
0	0	0	0	1	0	0	1	+9	
0	0	0	0	1	0	0	0	+8	
0	0	0	0	0	1	1	1	+7	
0	0	0	0	0	1	1	0	+6	
0	0	0	0	0	1	0	1	+5	
0	0	0	0	0	1	0	0	+4	
0	0	0	0	0	0	1	1	+3	
0	0	0	0	0	0	1	0	+2	
0	0	0	0	0	0	0	1	+1	
0	0	0	0	0	0	0	0	0 (note 1)	
0	0	0	1	1	1	1	1	-1	
0	0	0	1	1	1	1	0	-2	
0	0	0	1	1	1	0	1	-3	
0	0	0	1	1	1	0	0	-4	
0	0	0	1	1	0	1	1	-5	
0	0	0	1	1	0	1	0	-6	
0	0	0	1	1	0	0	1	-7	
0	0	0	1	1	0	0	0	-8	
0	0	0	1	0	1	1	1	-9	
0	0	0	1	0	1	1	0	-10	
0	0	0	1	0	1	0	1	-11	
0	0	0	1	0	1	0	0	-12	

**Note**

1. The default setting at power-up is 0000 0000.

## Digital TV Sound Processor (DTVSP)

## TDA9875A

## 10.3.30 TREBLE CONTROL REGISTER (AUXILIARY)

This register is used to apply treble control to the left and right signal channels of the Auxiliary channel.

Table 68 Subaddress 35

MSB							LSB		TREBLE SETTING (dB)
B7	B6	B5	B4	B3	B2	B1	B0		
X	X	X	0	1	1	0	0	+12	
X	X	X	0	1	0	1	1	+11	
X	X	X	0	1	0	1	0	+10	
X	X	X	0	1	0	0	1	+9	
X	X	X	0	1	0	0	0	+8	
X	X	X	0	0	1	1	1	+7	
X	X	X	0	0	1	1	0	+6	
X	X	X	0	0	1	0	1	+5	
X	X	X	0	0	1	0	0	+4	
X	X	X	0	0	0	1	1	+3	
X	X	X	0	0	0	1	0	+2	
X	X	X	0	0	0	0	1	+1	
X	X	X	0	0	0	0	0	0 (note 1)	
X	X	X	1	1	1	1	1	-1	
X	X	X	1	1	1	1	0	-2	
X	X	X	1	1	1	0	1	-3	
X	X	X	1	1	1	0	0	-4	
X	X	X	1	1	0	1	1	-5	
X	X	X	1	1	0	1	0	-6	
X	X	X	1	1	0	0	1	-7	
X	X	X	1	1	0	0	0	-8	
X	X	X	1	0	1	1	1	-9	
X	X	X	1	0	1	1	0	-10	
X	X	X	1	0	1	0	1	-11	
X	X	X	1	0	1	0	0	-12	

**Note**

1. The default setting at power-up is 0000 0000.

## Digital TV Sound Processor (DTVSP)

## TDA9875A

## 10.3.31 FEATURE INTERFACE CONFIGURATION REGISTER

**Table 69** Subaddress 36 (note 1)

BIT	NAME	VALUE	DESCRIPTION
7 (MSB)	B7	0	default value
6	B6	0	default value
5	B5	0	default value
4	SYSCL1	–	system clock frequency selection (see Table 70)
3	SYSCL0		
2	SYSOUT	1	enables the output of a system (or master) clock signal at pin SYSCLK
		0	the output will be off, thereby improving the EMC performance
1	I <sup>2</sup> SFORM	1	an MSB-aligned (MSB-first) serial output format is selected, i.e. a level change at pin WS indicates the beginning of a new audio sample
		0	the standard I <sup>2</sup> S-bus output format is selected
0 (LSB)	I <sup>2</sup> SOUT	1	enables the I <sup>2</sup> S-bus outputs (both serial data outputs plus serial bit clock and word select) in a format determined by bit I <sup>2</sup> SFORM; the TDA9875A is then an I <sup>2</sup> S-bus master
		0	the outputs mentioned will be 3-stated, thereby improving the EMC performance

**Note**

1. The default setting at power-up is 0000 0000.

**Table 70** System clock frequency selection

B4	B3	SYSCLK OUTPUT	FREQUENCY (MHz)
0	0	$256f_s$	8.192
0	1	$384f_s$	12.288
1	0	$512f_s$	16.384 <sup>(1)</sup>
1	1	$768f_s$	24.576

**Note**

1. With 16.384 MHz the duty cycle is 33%.

## Digital TV Sound Processor (DTVSP)

## TDA9875A

10.3.32 I<sup>2</sup>S1 OUTPUT SELECT REGISTER

This register is used to define both the signal source to be output at I<sup>2</sup>S1 and the mode of the digital matrix for signal selection.

**Table 71** Subaddress 37 (note 1)

BIT	NAME	VALUE	DESCRIPTION
7 (MSB)	B7	0	default value
6	B6	–	output selection (see Table 72)
5	B5		
4	B4		
3	B3	0	default value
2	B2	–	signal source selection (see Table 73)
1	B1		
0 (LSB)	B0		

**Note**

- The default setting at power-up is 0000 0000.

**Table 72** Output selection

B6	B5	B4	L OUTPUT	R OUTPUT
0	0	0	L input	R input
0	0	1	L input	L input
0	1	0	R input	R input
0	1	1	R input	L input
1	0	0	$\frac{L + R}{2}$	$\frac{L + R}{2}$

**Table 73** Signal source selection (note 1)

B2	B1	B0	SIGNAL SOURCE
0	0	0	FM output
0	0	1	NICAM output
0	1	0	I <sup>2</sup> S1 input
0	1	1	I <sup>2</sup> S2 input
1	0	0	ADC output
1	0	1	AVL output
1	1	0	Auxiliary output
1	1	1	Main output

**Note**

- The Main and Auxiliary channel outputs will not contain the beeper signal.

## Digital TV Sound Processor (DTVSP)

## TDA9875A

10.3.33 I<sup>2</sup>S1 INPUT LEVEL ADJUST REGISTER

This register is used to adjust the input level at the I<sup>2</sup>S1 interface. Left and right signal channel are treated identically.

Table 74 Subaddress 38

MSB							LSB		GAIN SETTING (dB)
B7	B6	B5	B4	B3	B2	B1	B0		
0	0	0	0	1	1	1	1	+15	
0	0	0	0	1	1	1	0	+14	
0	0	0	0	1	1	0	1	+13	
0	0	0	0	1	1	0	0	+12	
0	0	0	0	1	0	1	1	+11	
0	0	0	0	1	0	1	0	+10	
0	0	0	0	1	0	0	1	+9	
0	0	0	0	1	0	0	0	+8	
0	0	0	0	0	1	1	1	+7	
0	0	0	0	0	1	1	0	+6	
0	0	0	0	0	1	0	1	+5	
0	0	0	0	0	1	0	0	+4	
0	0	0	0	0	0	1	1	+3	
0	0	0	0	0	0	1	0	+2	
0	0	0	0	0	0	0	1	+1	
0	0	0	0	0	0	0	0	0 (note 1)	
0	0	0	1	1	1	1	1	-1	
0	0	0	1	1	1	1	0	-2	
0	0	0	1	1	1	0	1	-3	
0	0	0	1	1	1	0	0	-4	
0	0	0	1	1	0	1	1	-5	
0	0	0	1	1	0	1	0	-6	
0	0	0	1	1	0	0	1	-7	
0	0	0	1	1	0	0	0	-8	
0	0	0	1	0	1	1	1	-9	
0	0	0	1	0	1	1	0	-10	
0	0	0	1	0	1	0	1	-11	
0	0	0	1	0	1	0	0	-12	
0	0	0	1	0	0	1	1	-13	
0	0	0	1	0	0	1	0	-14	
0	0	0	1	0	0	0	1	-15	
0	0	0	1	0	0	0	0	mute	

**Note**

1. The default setting at power-up is 0000 0000.

## Digital TV Sound Processor (DTVSP)

## TDA9875A

10.3.34 I<sup>2</sup>S1 OUTPUT LEVEL ADJUST REGISTER

This register is used to adjust the output level at the I<sup>2</sup>S1 interface. Left and right signal channel are treated identically.

Table 75 Subaddress 39

MSB				LSB				GAIN SETTING (dB)
B7	B6	B5	B4	B3	B2	B1	B0	
0	0	0	0	1	1	1	1	+15
0	0	0	0	1	1	1	0	+14
0	0	0	0	1	1	0	1	+13
0	0	0	0	1	1	0	0	+12
0	0	0	0	1	0	1	1	+11
0	0	0	0	1	0	1	0	+10
0	0	0	0	1	0	0	1	+9
0	0	0	0	1	0	0	0	+8
0	0	0	0	0	1	1	1	+7
0	0	0	0	0	1	1	0	+6
0	0	0	0	0	1	0	1	+5
0	0	0	0	0	1	0	0	+4
0	0	0	0	0	0	1	1	+3
0	0	0	0	0	0	1	0	+2
0	0	0	0	0	0	0	1	+1
0	0	0	0	0	0	0	0	0 (note 1)
0	0	0	1	1	1	1	1	-1
0	0	0	1	1	1	1	0	-2
0	0	0	1	1	1	0	1	-3
0	0	0	1	1	1	0	0	-4
0	0	0	1	1	0	1	1	-5
0	0	0	1	1	0	1	0	-6
0	0	0	1	1	0	0	1	-7
0	0	0	1	1	0	0	0	-8
0	0	0	1	0	1	1	1	-9
0	0	0	1	0	1	1	0	-10
0	0	0	1	0	1	0	1	-11
0	0	0	1	0	1	0	0	-12
0	0	0	1	0	0	1	1	-13
0	0	0	1	0	0	1	0	-14
0	0	0	1	0	0	0	1	-15
0	0	0	1	0	0	0	0	mute

**Note**

1. The default setting at power-up is 0000 0000.

## Digital TV Sound Processor (DTVSP)

## TDA9875A

10.3.35 I<sup>2</sup>S2 OUTPUT SELECT REGISTER

This register is used to define both the signal source to be output at I<sup>2</sup>S2 and the mode of the digital matrix for signal selection.

**Table 76** Subaddress 40 (note 1)

BIT	NAME	VALUE	DESCRIPTION
7 (MSB)	B7	0	default value
6	B6	–	output selection (see Table 77)
5	B5		
4	B4		
3	B3	0	default value
2	B2	–	signal source selection (see Table 78)
1	B1		
0 (LSB)	B0		

**Note**

- The default setting at power-up is 0000 0000.

**Table 77** Output selection

B6	B5	B4	L OUTPUT	R OUTPUT
0	0	0	L input	R input
0	0	1	L input	L input
0	1	0	R input	R input
0	1	1	R input	L input
1	0	0	$\frac{L + R}{2}$	$\frac{L + R}{2}$

**Table 78** Signal source selection (note 1)

B2	B1	B0	SIGNAL SOURCE
0	0	0	FM output
0	0	1	NICAM output
0	1	0	I <sup>2</sup> S1 input
0	1	1	I <sup>2</sup> S2 input
1	0	0	ADC output
1	0	1	AVL output
1	1	0	Auxiliary output
1	1	1	Main output

**Note**

- The Main and Auxiliary channel outputs will not contain the beeper signal.



## Digital TV Sound Processor (DTVSP)

## TDA9875A

10.3.36 I<sup>2</sup>S2 INPUT LEVEL ADJUST REGISTER

This register is used to adjust the input level at the I<sup>2</sup>S2 interface. Left and right signal channel are treated identically.

Table 79 Subaddress 41

MSB							LSB	GAIN SETTING (dB)
B7	B6	B5	B4	B3	B2	B1	B0	
0	0	0	0	1	1	1	1	+15
0	0	0	0	1	1	1	0	+14
0	0	0	0	1	1	0	1	+13
0	0	0	0	1	1	0	0	+12
0	0	0	0	1	0	1	1	+11
0	0	0	0	1	0	1	0	+10
0	0	0	0	1	0	0	1	+9
0	0	0	0	1	0	0	0	+8
0	0	0	0	0	1	1	1	+7
0	0	0	0	0	1	1	0	+6
0	0	0	0	0	1	0	1	+5
0	0	0	0	0	1	0	0	+4
0	0	0	0	0	0	1	1	+3
0	0	0	0	0	0	1	0	+2
0	0	0	0	0	0	0	1	+1
0	0	0	0	0	0	0	0	0 (note 1)
0	0	0	1	1	1	1	1	-1
0	0	0	1	1	1	1	0	-2
0	0	0	1	1	1	0	1	-3
0	0	0	1	1	1	0	0	-4
0	0	0	1	1	0	1	1	-5
0	0	0	1	1	0	1	0	-6
0	0	0	1	1	0	0	1	-7
0	0	0	1	1	0	0	0	-8
0	0	0	1	0	1	1	1	-9
0	0	0	1	0	1	1	0	-10
0	0	0	1	0	1	0	1	-11
0	0	0	1	0	1	0	0	-12
0	0	0	1	0	0	1	1	-13
0	0	0	1	0	0	1	0	-14
0	0	0	1	0	0	0	1	-15
0	0	0	1	0	0	0	0	mute

**Note**

1. The default setting at power-up is 0000 0000.

## Digital TV Sound Processor (DTVSP)

## TDA9875A

10.3.37 I<sup>2</sup>S2 OUTPUT LEVEL ADJUST REGISTER

This register is used to adjust the output level at the I<sup>2</sup>S2 interface. Left and right signal channel are treated identically.

**Table 80** Subaddress 42

MSB							LSB	GAIN SETTING (dB)
B7	B6	B5	B4	B3	B2	B1	B0	
0	0	0	0	1	1	1	1	+15
0	0	0	0	1	1	1	0	+14
0	0	0	0	1	1	0	1	+13
0	0	0	0	1	1	0	0	+12
0	0	0	0	1	0	1	1	+11
0	0	0	0	1	0	1	0	+10
0	0	0	0	1	0	0	1	+9
0	0	0	0	1	0	0	0	+8
0	0	0	0	0	1	1	1	+7
0	0	0	0	0	1	1	0	+6
0	0	0	0	0	1	0	1	+5
0	0	0	0	0	1	0	0	+4
0	0	0	0	0	0	1	1	+3
0	0	0	0	0	0	1	0	+2
0	0	0	0	0	0	0	1	+1
0	0	0	0	0	0	0	0	0 (note 1)
0	0	0	1	1	1	1	1	-1
0	0	0	1	1	1	1	0	-2
0	0	0	1	1	1	0	1	-3
0	0	0	1	1	1	0	0	-4
0	0	0	1	1	0	1	1	-5
0	0	0	1	1	0	1	0	-6
0	0	0	1	1	0	0	1	-7
0	0	0	1	1	0	0	0	-8
0	0	0	1	0	1	1	1	-9
0	0	0	1	0	1	1	0	-10
0	0	0	1	0	1	0	1	-11
0	0	0	1	0	1	0	0	-12
0	0	0	1	0	0	1	1	-13
0	0	0	1	0	0	1	0	-14
0	0	0	1	0	0	0	1	-15
0	0	0	1	0	0	0	0	mute

**Note**

1. The default setting at power-up is 0000 0000.

## Digital TV Sound Processor (DTVSP)

## TDA9875A

## 10.3.38 BEEPER FREQUENCY CONTROL REGISTER

This register is used to select from sample beeper oscillator frequencies. The beeper output signal is added to the Main and Auxiliary channel output DAC.

Due to the frequency response of the audio DACs upsampling filters, the 25 kHz beep is approximately 5 dB louder than the 390 Hz beep.

**Table 81** Subaddress 43 (note 1)

MSB							LSB		GENERATED FREQUENCY (Hz)
B7	B6	B5	B4	B3	B2	B1	B0		
0	0	0	0	0	1	1	1	25000	
0	0	0	0	0	1	1	0	7040	
0	0	0	0	0	1	0	1	3580	
0	0	0	0	0	1	0	0	1770	
0	0	0	0	0	0	1	1	1270	
0	0	0	0	0	0	1	0	900	
0	0	0	0	0	0	0	1	640	
0	0	0	0	0	0	0	0	390	

**Note**

1. The default setting at power-up is 0000 0000.

## 10.3.39 BEEPER VOLUME CONTROL REGISTER

This register is used to set the beeper volume. The gain setting is relative to digital full-scale at the input to the Main and Auxiliary channel output DACs. The beeper volume is independent of any other volume setting.

The beeper signal is added to the Main and Auxiliary channel output signals in the  $2 \times f_s$  domain. The beeper volume should be set with great care, when the audio signals in the Main and Auxiliary channels are close to digital full-scale, to avoid output signal distortion due to overload.

## Digital TV Sound Processor (DTVSP)

## TDA9875A

Table 82 Subaddress 44

MSB							LSB		GAIN SETTING (dB)
B7	B6	B5	B4	B3	B2	B1	B0		
0	0	0	0	0	0	0	0	0	
0	0	1	1	1	1	1	1	-3	
0	0	1	1	1	1	1	0	-6	
0	0	1	1	1	1	0	1	-9	
0	0	1	1	1	1	0	0	-12	
0	0	1	1	1	0	1	1	-15	
0	0	1	1	1	0	1	0	-18	
0	0	1	1	1	0	0	1	-21	
0	0	1	1	1	0	0	0	-24	
0	0	1	1	0	1	1	1	-27	
0	0	1	1	0	1	1	0	-30	
0	0	1	1	0	1	0	1	-33	
0	0	1	1	0	1	0	0	-36	
0	0	1	1	0	0	1	1	-39	
0	0	1	1	0	0	1	0	-42	
0	0	1	1	0	0	0	1	-45	
0	0	1	1	0	0	0	0	-48	
0	0	1	0	1	1	1	1	-51	
0	0	1	0	1	1	1	0	-54	
0	0	1	0	1	1	0	1	-57	
0	0	1	0	1	1	0	0	-60	
0	0	1	0	1	0	1	1	-63	
0	0	1	0	1	0	1	0	-66	
0	0	1	0	1	0	0	1	-69	
0	0	1	0	1	0	0	0	-72	
0	0	1	0	0	1	1	1	-75	
0	0	1	0	0	1	1	0	-78	
0	0	1	0	0	1	0	1	-81	
0	0	1	0	0	1	0	0	-84	
0	0	1	0	0	0	1	1	-87	
0	0	1	0	0	0	1	0	-90	
0	0	1	0	0	0	0	1	-93	
0	0	1	0	0	0	0	0	mute (note 1)	

**Note**

1. The default setting at power-up is 0010 0000.

## Digital TV Sound Processor (DTVSP)

## TDA9875A

## 10.3.40 BASS BOOST CONTROL REGISTER

This register is used to select from a few sample bass boost settings to modify the frequency characteristics of the Main channel (shelving filter). Bits B3 to B0 apply to the left channel, bits B7 to B4 apply to the right channel. This function must be used with care in order to avoid clipping distortion at high volume settings.

More sophisticated control of the bass boost filter can be exercised in the expert mode (see Section 10.5). The user then has full control over this second-order filter and can, within limits, realize bass equalizers with arbitrary centre frequencies, Q factors and boost/cut settings.

**Table 83** Subaddress 45 (note 1)

BIT	NAME	VALUE	DESCRIPTION
7 (MSB)	B7	–	gain setting of right channel (see Table 84)
6	B6		
5	B5		
4	B4		
3	B3	–	gain setting of left channel (see Table 85)
2	B2		
1	B1		
0 (LSB)	B0		

**Note**

1. The default setting at power-up is 0000 0000.

**Table 84** Gain setting right channel

B7	B6	B5	B4	GAIN SETTING (dB)	CORNER FREQUENCY (Hz)
1	0	1	0	20	350
1	0	0	1	18	350
1	0	0	0	16	350
0	1	1	1	14	350
0	1	1	0	12	350
0	1	0	1	10	350
0	1	0	0	8	350
0	0	1	1	6	350
0	0	1	0	4	350
0	0	0	1	2	350
0	0	0	0	0	350

## Digital TV Sound Processor (DTVSP)

TDA9875A

**Table 85** Gain setting left channel

<b>B3</b>	<b>B2</b>	<b>B1</b>	<b>B0</b>	<b>GAIN SETTING (dB)</b>	<b>CORNER FREQUENCY (Hz)</b>
1	0	1	0	20	350
1	0	0	1	18	350
1	0	0	0	16	350
0	1	1	1	14	350
0	1	1	0	12	350
0	1	0	1	10	350
0	1	0	0	8	350
0	0	1	1	6	350
0	0	1	0	4	350
0	0	0	1	2	350
0	0	0	0	0	350

## Digital TV Sound Processor (DTVSP)

## TDA9875A

**10.4 Slave transmitter mode**

As a slave transmitter, the TDA9875A provides 13 registers with status information and data, a part of which is for Philips internal purposes only. These registers can be accessed by means of subaddresses.

**Table 86** General format for reading data from the TDA9875A

S	SLAVE ADDRESS	0	ACK	SUBADDRESS	ACK	Sr	SLAVE ADDRESS	1	ACK	DATA	NAm	P
---	---------------	---	-----	------------	-----	----	---------------	---	-----	------	-----	---

**Table 87** Explanation of Tables 86 and 88

BIT	FUNCTION
S	START condition
SLAVE ADDRESS	7-bit device address
0	data direction bit (write to device)
ACK	acknowledge (by the slave)
SUBADDRESS	address of register to read from
Sr	repeated START condition
1	data direction bit (read from device)
DATA	data byte read from register
NAm	not acknowledge (by the master)
Am	acknowledge (by the master)
P	STOP condition

Reading of data can start at any valid subaddress. It is allowed to read more than 1 data byte per transmission from the TDA9875A. In this situation, the subaddress is automatically incremented after each data byte, which results in reading the sequence of data bytes from successive register locations, starting at SUBADDRESS.

**Table 88** Format of a transmission using automatic incrementing of subaddresses

S	SLAVE ADDRESS	0	ACK	SUBADDRESS	ACK	Sr	SLAVE ADDRESS	1	ACK	DATA BYTE Am <sup>(1)</sup>	DATA	NAm	P
---	---------------	---	-----	------------	-----	----	---------------	---	-----	--------------------------------	------	-----	---

**Note**

1. n data bytes with auto-increment of subaddresses.

Each data byte in a read sequence, except for the last one, is acknowledged with Am (acknowledge by the master). The subaddresses 'wrap around' from decimal 255 to 0. If an attempt is made to read from a non-existing subaddress, the device will send a data pattern of all ones, i.e. FF in hexadecimal notation.

## Digital TV Sound Processor (DTVSP)

TDA9875A

**Table 89** Overview of the slave transmitter registers (note 1)

SUBADDRESS (DECIMAL)	DATA								FUNCTION
	MSB				LSB				
0	s	s	s	s	s	s	s	s	device status (power-on, identification, etc.)
1	s	s	s	s	s	s	s	s	NICAM status
2	e	e	e	e	e	e	e	e	NICAM error count
3	d	d	d	d	d	d	d	d	additional data (LSB)
4	c	c	X	c	c	d	d	d	additional data (MSB)
5	l	l	l	l	l	l	l	l	level read-out (MSB)
6	l	l	l	l	l	l	l	l	level read-out (LSB)
7	X	X	X	c	c	c	c	c	SIF level
251	a	a	a	a	a	a	a	a	test register 3; note 2
252	a	a	a	a	a	a	a	a	test register 2; note 2
253	a	a	a	a	a	a	a	a	test register 1; note 2
254	d	d	d	d	d	d	d	d	device identification code
255	s	s	s	s	s	s	s	s	software identification code

**Notes**

1. X indicates a bit that has not been assigned to a function. This bit is reserved for future extensions.
2. Registers from subaddress 251 to 255 are for Philips internal purposes only. They are considered as a set of registers for the identification of individual members and some key parameters in a family of devices.

The following sub-sections provide a detailed description of the slave transmitter registers.



## Digital TV Sound Processor (DTVSP)

## TDA9875A

## 10.4.1 DEVICE STATUS REGISTER

**Table 90** Subaddress 0

BIT	NAME	VALUE	DESCRIPTION
7 (MSB)	P2IN	–	This bit reflects the status of the corresponding general purpose port of pin P2 (see Section 10.3.2).
6	P1IN	–	This bit reflects the status of the corresponding general purpose port of pin P1 (see Section 10.3.2).
5	RSSF	1	Reserve sound switching flag: this bit is a copy of the C4 bit in the NICAM status register. It indicates that the FM (or AM for standard L) sound matches the digital transmission and auto-muting should be enabled.
		0	Auto-muting should be disabled, as analog and digital sound are different.
4	AMSTAT	1	Auto-mute status: it indicates that the auto-muting function has switched from NICAM to the program of the first sound carrier (i.e. FM mono or AM in the NICAM L system) or to the ADC (depending on bit AMSEL).
		0	Auto-muting function has not switched.
3	VDSP	1	Indicates that digital transmission is a sound source (NICAM).
		0	The transmission is either data or currently undefined format (NICAM).
2	IDDUA	–	This bit is logic 1 if an FM dual-language signal has been identified. When neither IDSTE nor IDDUA are set, the received signal has to be assumed to be FM mono.
1	IDSTE	–	This bit is logic 1 if an FM stereo signal has been identified.
0 (LSB)	POR	–	Power fail bit: the power supply for the digital part of the device, $V_{DD2}$ , has temporarily been lower than the specified lower limit. If this is detected an initialization of the TDA9875A has to be carried out to ensure a reliable operation.

## Digital TV Sound Processor (DTVSP)

## TDA9875A

## 10.4.2 NICAM STATUS REGISTER

The TDA9875A does not support the Extended Control Modes. Therefore, the program of the first sound carrier (i.e. FM mono or AM) is selected for reproduction in case bit C3 is set to logic 1, independent of bit AMUTE in the NICAM configuration register being set or not.

When a NICAM transmitter is switched off, the device will lose synchronization. In this situation the program of the first sound carrier is selected for reproduction, independent of bit AMUTE being set or not.

**Table 91** Subaddress 1

BIT	NAME	VALUE	DESCRIPTION
7 (MSB)	C4	–	application control bits (C1 to C4 in the NICAM transmission)
6	C3		
5	C2		
4	C1		
3	OSB	1	indication that the device has both frame and C0 (16 frame) synchronization
		0	the audio output from the NICAM part should be digital silence
2	CFC	1	indication of a configuration change at the 16 frame (C0) boundary
		0	no configuration change
1	S/MB	1	indication of NICAM stereo mode
		0	no NICAM stereo mode
0 (LSB)	D/SB	1	indication NICAM dual mono mode
		0	no NICAM dual mono mode

## 10.4.3 NICAM ERROR COUNT REGISTER

Bits B7 to B0 contain the number of errors occurring in the previous 128 ms period. The register is updated every 128 ms.

**Table 92** Subaddress 2

BIT	NAME	VALUE	DESCRIPTION
7 (MSB)	B7	–	number of errors
6	B6		
5	B5		
4	B4		
3	B3		
2	B2		
1	B1		
0 (LSB)	B0		

## Digital TV Sound Processor (DTVSP)

TDA9875A

## 10.4.4 ADDITIONAL DATA REGISTERS

These two bytes provide information on the additional data bits.

**Table 93** Subaddress 3

BIT	NAME	VALUE	DESCRIPTION
7 (MSB)	AD7	–	comprise the additional data word
6	AD6		
5	AD5		
4	AD4		
3	AD3		
2	AD2		
1	AD1		
0 (LSB)	AD0		

**Table 94** Subaddress 4

BIT	NAME	VALUE	DESCRIPTION
7 (MSB)	OVW	1	new additional data bits are written to the IC without the previous bits being read
		0	no bits are written
6	SAD	1	new additional data is written into the IC
		0	this bit is set to logic 0 when the additional data bits are read
5	X	–	don't care
4	CI1	–	these are CI bits decoded by majority logic from the parity checks of the last ten samples in a frame
3	CI2		
2	AD10	–	comprise the additional data word
1	AD9		
0 (LSB)	AD8		

## Digital TV Sound Processor (DTVSP)

## TDA9875A

## 10.4.5 LEVEL READ-OUT REGISTERS

These two bytes constitute a word that provides data from a location that has been specified with the monitor select register. The most significant byte of the data is stored at subaddress 5.

If peak-level monitoring has been selected, the peak-level monitoring register is cleared and monitoring resumes after its contents has been transferred to these two bytes.

Table 95 Subaddresses 5 and 6

SUB-ADDRESS	BIT	DESCRIPTION
5	7 (MSB)	most significant bit or sign bit
	6	
	5	
	4	
	3	
	2	
	1	
	0 (LSB)	
6	7 (MSB)	
	6	
	5	
	4	
	3	
	2	
	1	
	0 (LSB)	least significant bit

## 10.4.6 SIF LEVEL REGISTER

When the SIF AGC is on, bits B4 to B0 of this register contain a number that gives an indication of the SIF input level. That number corresponds to the AGC gain register setting (see Section 10.3.1).

When the SIF AGC is off, this register returns the contents of the AGC gain register.

Table 96 Subaddress 7

BIT	NAME	VALUE	DESCRIPTION
7 (MSB)	B7	X	bit not assigned
6	B6	X	bit not assigned
5	B5	X	bit not assigned
4	B4	–	indication of SIF input level
3	B3		
2	B2		
1	B1		
0 (LSB)	B0		

## 10.4.7 TEST REGISTER 3

This register contains, as a binary number, the highest memory address used for the Coefficient RAM (CRAM, expert mode).

Table 97 Subaddress 251

MSB							LSB
B7	B6	B5	B4	B3	B2	B1	B0
0	1	1	1	1	1	1	1

## 10.4.8 TEST REGISTER 2

This register contains, as a binary number, the highest subaddress used for slave receiver registers.

Table 98 Subaddress 252

MSB							LSB
B7	B6	B5	B4	B3	B2	B1	B0
0	0	1	0	1	1	0	1

## Digital TV Sound Processor (DTVSP)

## TDA9875A

## 10.4.9 TEST REGISTER 1

This register contains, as a binary number, the highest subaddress used for slave transmitter (status) registers.

Table 99 Subaddress 253

MSB							LSB
B7	B6	B5	B4	B3	B2	B1	B0
0	0	0	0	0	1	1	1

## 10.4.10 DEVICE IDENTIFICATION CODE

There will be several devices in the digital TV sound processor family. This byte is used to identify the individual family members.

Table 100 Subaddress 254

MSB							LSB
B7	B6	B5	B4	B3	B2	B1	B0
0	0	0	0	0	0	1	0

## 10.4.11 SOFTWARE IDENTIFICATION CODE

It is likely that during the life time of this family of devices several versions of the DSP software will be made, e.g., to accommodate new application concepts, respond to customer wishes, etc. This byte is used to identify the different releases.

Table 101 Subaddress 255

MSB							LSB
B7	B6	B5	B4	B3	B2	B1	B0
0	0	0	0	0	0	1	0

## 10.5 Expert mode

In addition to the slave receiver and slave transmitter modes previously described, there is a special 'expert' mode that gives direct write access to the internal CRAM of the DSP.

In this mode, transferred data contain 12-bit coefficients. As these coefficients bypass on-chip coefficient look-up tables for many functions, they directly influence the processing of signals within the DSP.

This mode must be used with great care. It can be used to create user-defined characteristics, such as a tone control with different corner frequencies or special boost/cut characteristics to correct the low-frequency loudspeaker and/or cabinet frequency responses.

As the coefficients do not fit into one data byte, they have to be split and arranged (see Table 104). The most significant bit is transferred first.

The general format described in Table 104 shows the minimum number of data bytes required, i.e. two bytes for the transfer of a single coefficient.

Should more than one coefficient be sent, then the CRAM address will be automatically incremented after each coefficient, resulting in writing the sequence of coefficients into successive memory locations, starting at CRAM ADDRESS. A transmission can start with any valid CRAM address. If two coefficients are to be transferred, they are arranged as shown in Table 105.

With any odd number of coefficients to be transferred, the least significant nibble of the last byte is regarded as containing don't care data.

As the transfer of coefficients cannot be accomplished within one audio sample period, it is necessary that received coefficients be buffered and made active all at the same time to avoid audio signal transients. The receive buffer is designed to store up to 8 coefficients in addition to the CRAM address. Each byte that fits into the buffer is acknowledged with ACK (acknowledge). If an attempt is made to write more coefficients than the buffer can store, the device acknowledges with NACK (not acknowledge) and any further coefficients are ignored. Coefficients that are already in the receive buffer remain intact.

An expert mode transfer ends when the I<sup>2</sup>C-bus STOP condition or a repeated START condition has been detected. Only those coefficients that have been received during the last transmission will then be copied from the buffer to the CRAM.

To make efficient and correct use of the expert mode, it is recommended to transfer all coefficients for any one function in a single transmission.

There is no checking of memory addresses and the automatic incrementing of addresses does not stop at the highest used CRAM address. The user of this expert mode must be fully acquainted with the relevant procedures.

More information concerning the functions of this device, such as the number of coefficients per function, their default values, memory addresses, etc., can be supplied on request at a later date.

## Digital TV Sound Processor (DTVSP)

## TDA9875A

**Table 102** General format for entering the expert mode and writing coefficients into the TDA9875A

S	SLAVE ADDRESS	0	ACK	10000000	ACK	CRAM ADDRESS	ACK	DATA	ACK	DATA	ACK	P
---	---------------	---	-----	----------	-----	--------------	-----	------	-----	------	-----	---

**Table 103** Explanation of Table 102

BIT	FUNCTION
S	START condition
SLAVE ADDRESS	7-bit device address
0	data direction bit (write to device)
ACK	acknowledge
10000000	pattern to enter the expert mode
CRAM ADDRESS	start address of coefficient RAM to write to
DATA	data byte containing part of a coefficient
P	STOP condition

**Table 104** General format (notes 1, 2 and 3)

BYTE	DATA								DESCRIPTION
1 data byte	a	a	a	a	a	a	a	a	2 MST of 1st coefficient
2 data byte	a	a	a	a	X	X	X	X	1 LST of 1st coefficient

**Notes**

1. X = don't care.
2. MST = most significant third.
3. LST = least significant third.

**Table 105** Transfer of two coefficients

BYTE	DATA								DESCRIPTION
1 data byte	a	a	a	a	a	a	a	a	2 MST of 1st coefficient
2 data byte	a	a	a	a	b	b	b	b	1 LST of 1st coefficient + 1 MST of 2nd coefficient
3 data byte	b	b	b	b	b	b	b	b	2 LST of 2nd coefficient

## Digital TV Sound Processor (DTVSP)

## TDA9875A

### 11 I<sup>2</sup>S-BUS DESCRIPTION

The feature interface of the TDA9875A contains two serial audio inputs and outputs and associated clock signals. It can be used to supply, for example, audio signals from received TV programs to a digital audio output device (AES/EBU format), or import serial audio signals from other sources for reproduction through the TV set's loudspeaker and/or headphone channels. Apart from such simple data input or output, it is also possible to run audio signals through an external DSP, which performs some additional functions, such as room simulation, Dolby Surround Pro Logic etc. and feed those signals back into the loudspeaker and/or headphone channels of the TDA9875A.

Two serial audio formats are supported at the feature interface, i.e. the I<sup>2</sup>S-bus format and a very similar MSB-aligned format. The difference is illustrated in Fig.9.

In both formats the left audio channel of a stereo sample pair is output first and is placed on the serial data line (SDI for input, SDO for output) when the Word Select line (WS) is LOW. Data is written at the trailing edge of SCK and read at the leading edge of SCK. The most significant bit is sent first.

At power-up, the outputs of the feature interface are 3-stated to reduce EMC and allow for combinations with other ICs. If output is desired, it has to be activated by means of an I<sup>2</sup>C-bus command.

When the output is enabled, the serial audio data can be taken from pins SDO1 and SDO2. Depending on the signal source, switch and matrix positions, the output can be either mono, stereo or dual language sound on either output.

The word select output is clocked with the audio sample frequency at 32 kHz. The serial clock output (SCK) is clocked at a frequency of 2.048 MHz. This means, that there are 64 clock pulses per pair of stereo output samples, or 32 clock pulses per sample. Depending again on the signal source, the number of significant bits on the serial data outputs, SDO1 and SDO2, is between 14 and 18.

Apart from just feeding a digital audio device, such as a DAC or an AES/EBU transmitter, the serial data outputs can be connected directly to the serial inputs (loop-back connection) or first to an external device, e.g. a feature DSP such as the SAA7710 and then back to the serial inputs. In all of these configurations, the SCK and WS clocks will be generated by the TDA9875A, which then is the I<sup>2</sup>S-bus master.

The serial data inputs, SDI1 and SDI2, are active at all times, independent of the serial data outputs being on or off. When the serial data outputs are off (either after power-up or via the appropriate I<sup>2</sup>C-bus command) serial data and clocks WS and SCK from a separate digital audio source can be fed into the TDA9875A, be processed and output in accordance with internal selector positions, provided that the following criteria are met:

- 32 kHz audio sample frequency
- 32 clock bits per sample
- External timing and data synchronized to TDA9875A.

In such cases, the external source is the I<sup>2</sup>S-bus master and the TDA9875A is the I<sup>2</sup>S-bus slave.

To support synchronization of external devices or as a master clock for them, a system clock output, SYSCLK, is available from the TDA9875A. At power-up it is off. It can be enabled and the output frequency set via an I<sup>2</sup>C-bus command. Available output frequencies are 8.192, 12.288, 16.384 and 24.576 MHz.

Digital TV Sound Processor (DTVSP)

TDA9875A

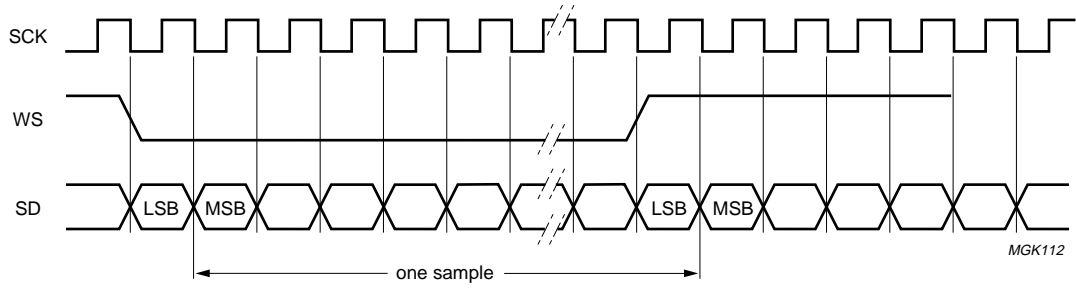

MGK112

a. I<sup>2</sup>S-bus format.

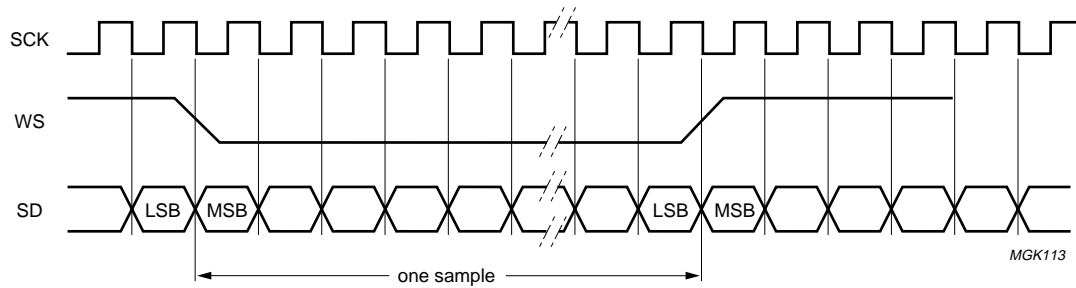

MGK113

b. MSB-aligned format.

Fig.9 Serial audio interface formats.



Digital TV Sound Processor (DTVSP)

TDA9875A

12 APPLICATION INFORMATION

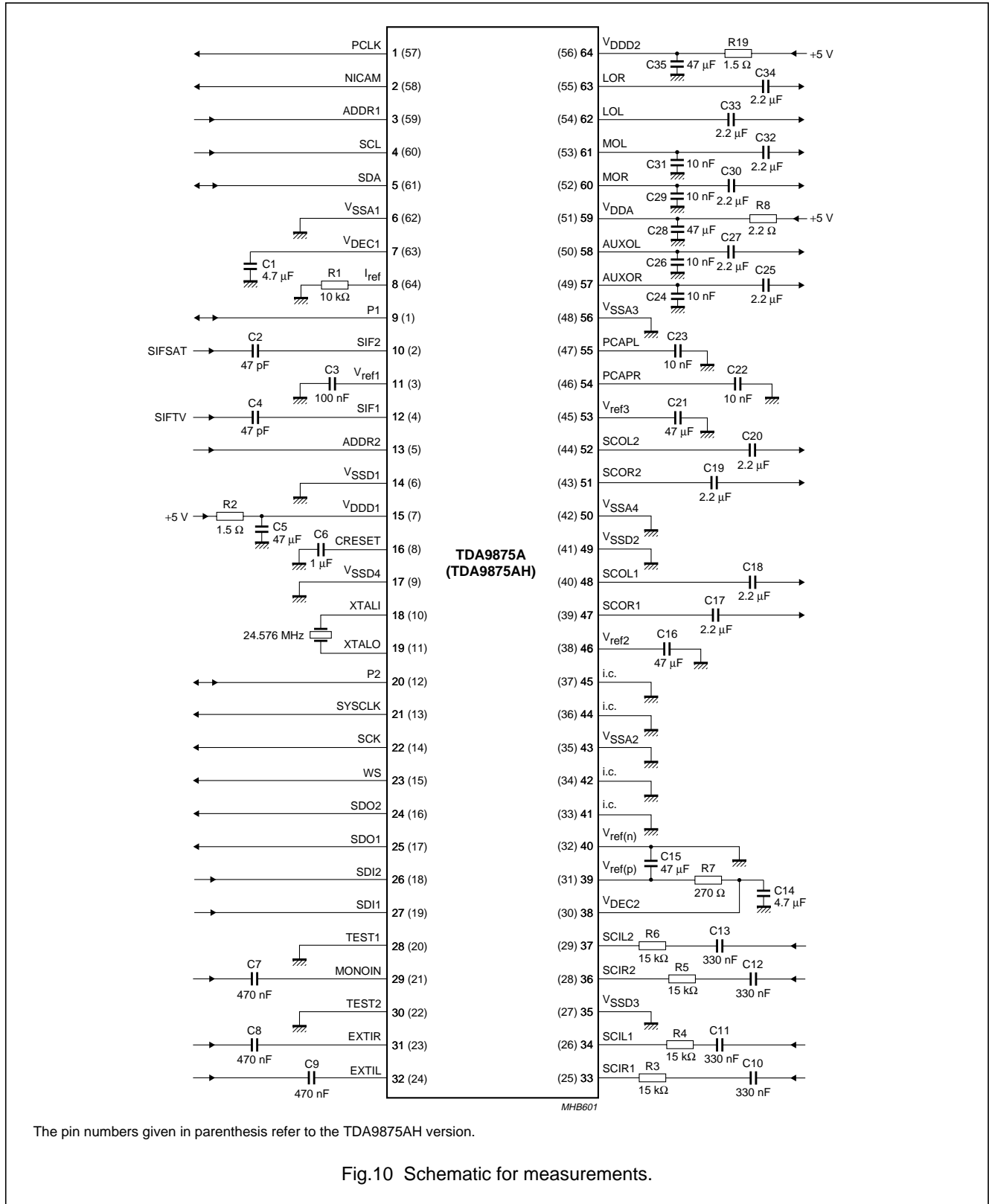

Digital TV Sound Processor (DTVSP)

TDA9875A

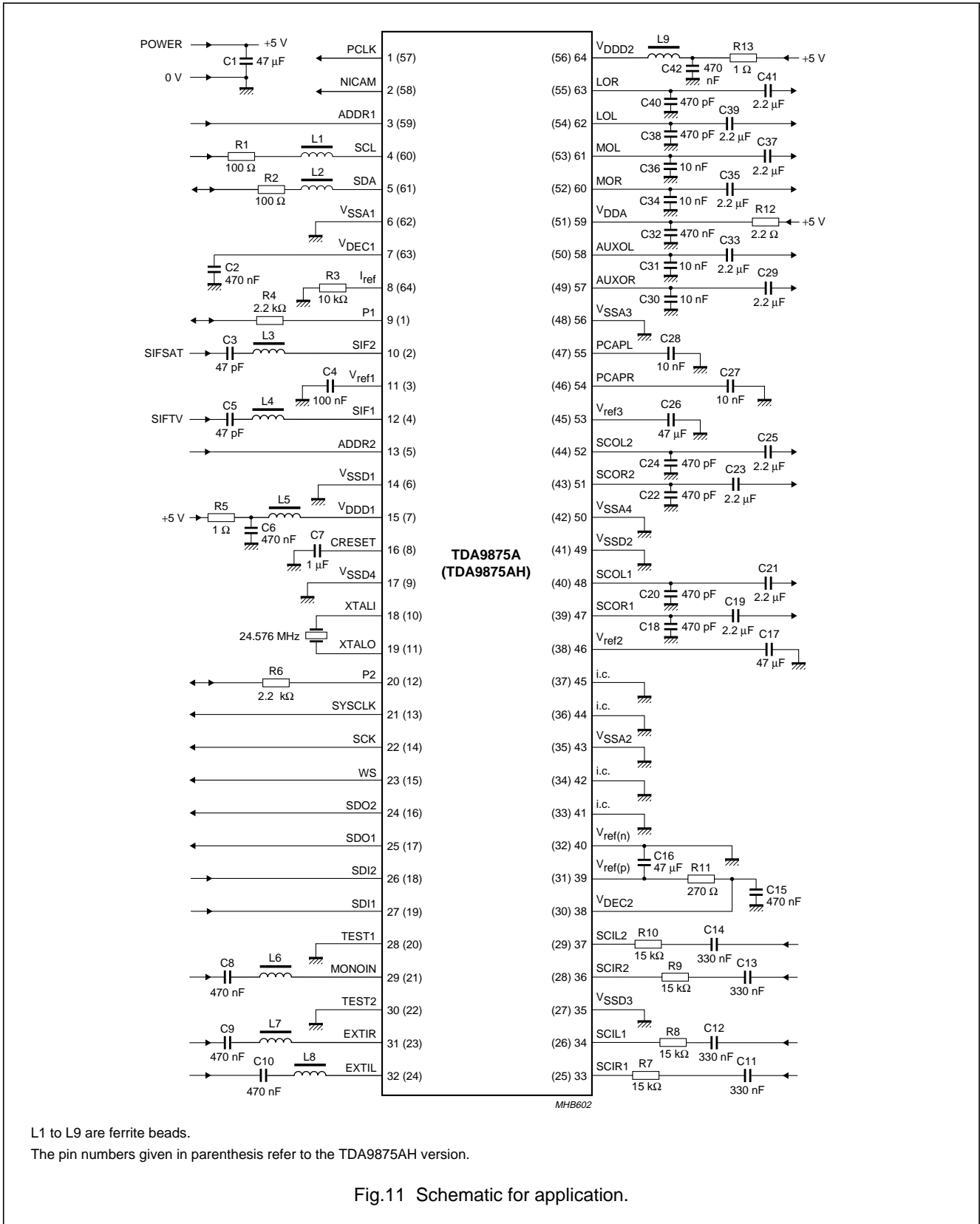

Digital TV Sound Processor (DTVSP)

TDA9875A

13 PACKAGE OUTLINES

SDIP64: plastic shrink dual in-line package; 64 leads (750 mil)

SOT274-1

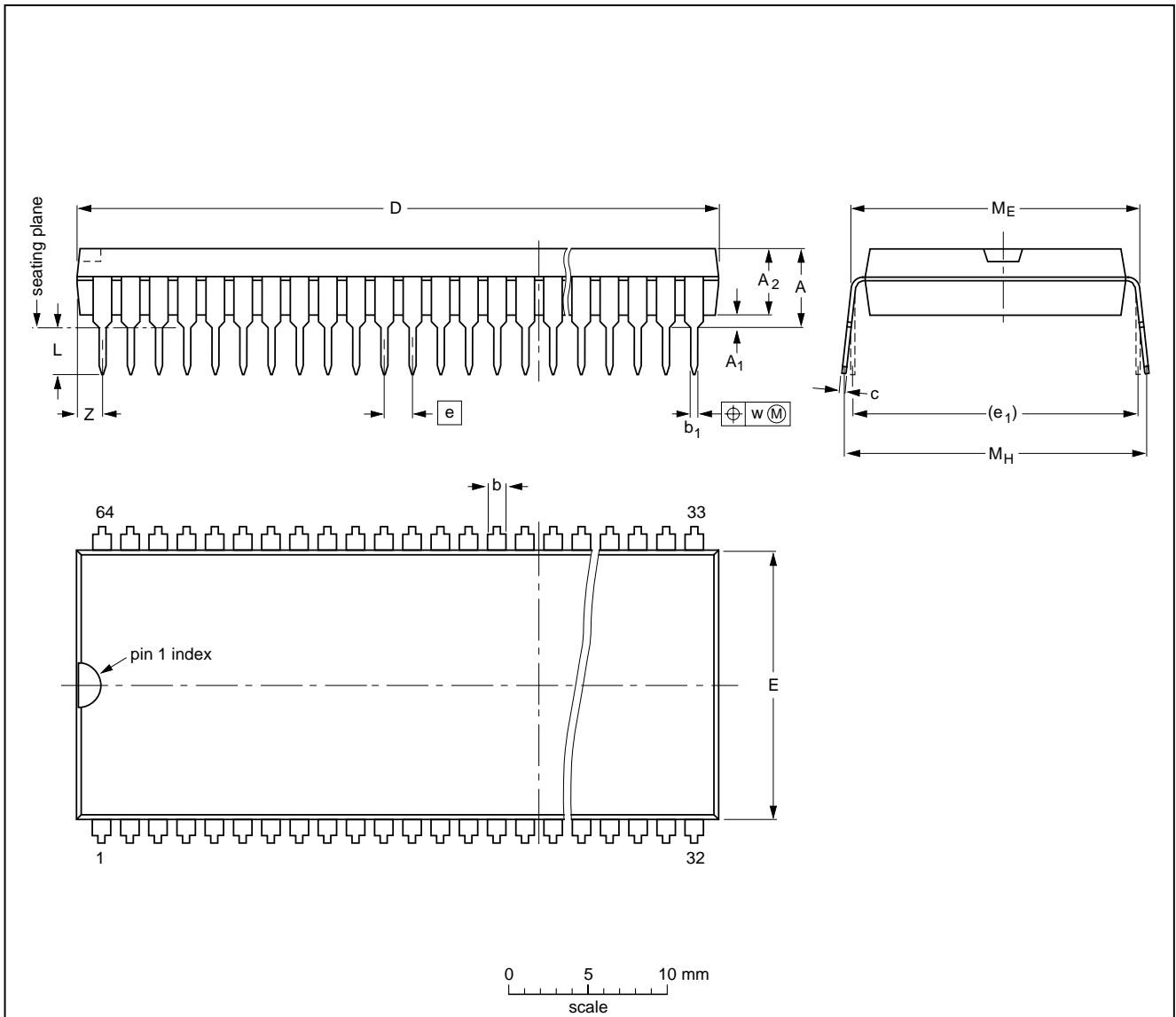

DIMENSIONS (mm are the original dimensions)

UNIT	A max.	A <sub>1</sub> min.	A <sub>2</sub> max.	b	b <sub>1</sub>	c	D <sup>(1)</sup>	E <sup>(1)</sup>	e	e <sub>1</sub>	L	M <sub>E</sub>	M <sub>H</sub>	w	Z <sup>(1)</sup> max.
mm	5.84	0.51	4.57	1.3 0.8	0.53 0.40	0.32 0.23	58.67 57.70	17.2 16.9	1.778	19.05	3.2 2.8	19.61 19.05	20.96 19.71	0.18	1.73

Note

1. Plastic or metal protrusions of 0.25 mm maximum per side are not included.

OUTLINE VERSION	REFERENCES				EUROPEAN PROJECTION	ISSUE DATE
	IEC	JEDEC	EIAJ			
SOT274-1		MS-021				95-02-04 99-12-27

Digital TV Sound Processor (DTVSP)

TDA9875A

QFP64: plastic quad flat package; 64 leads (lead length 1.6 mm); body 14 x 14 x 2.7 mm

SOT393-1

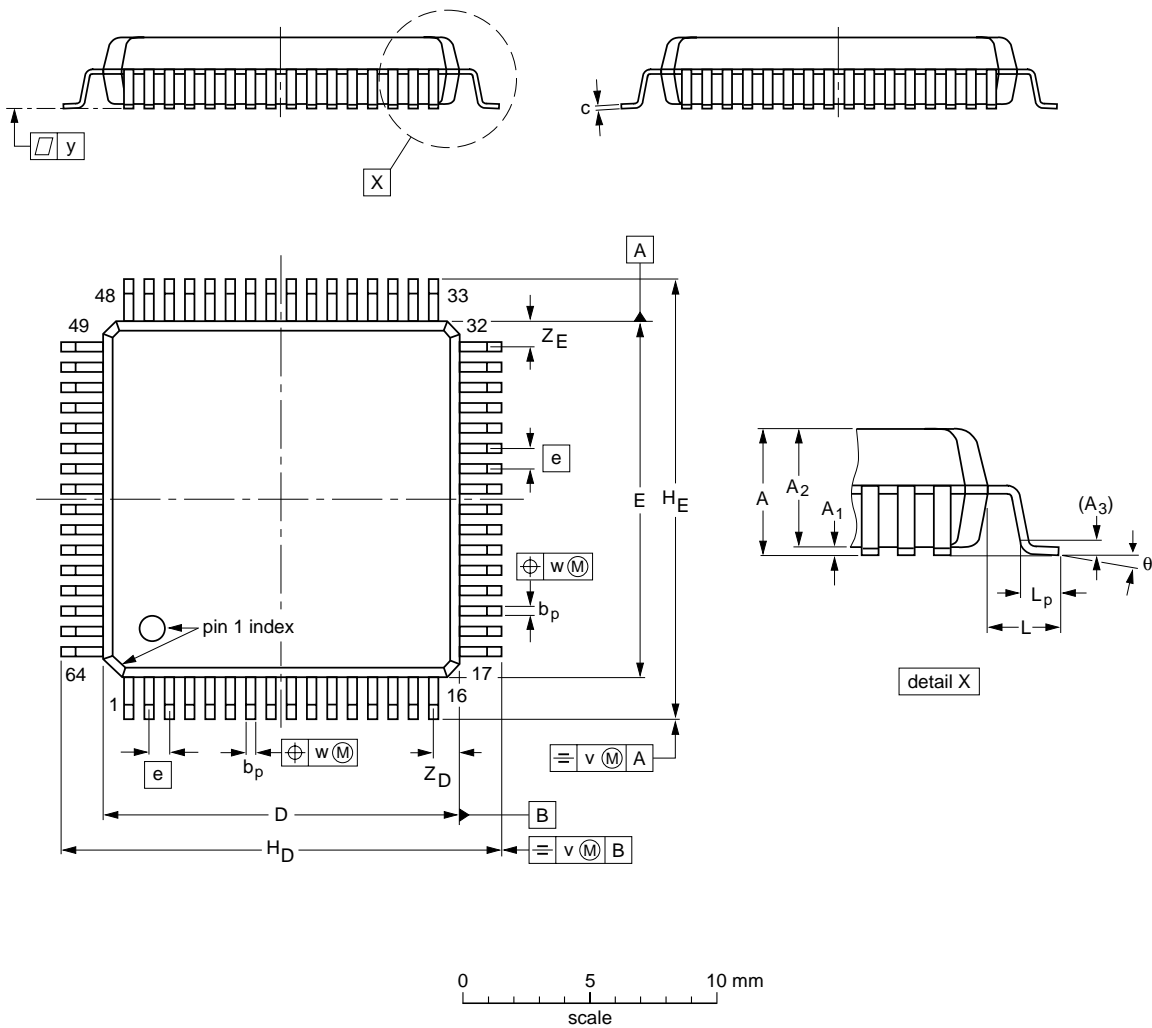

DIMENSIONS (mm are the original dimensions)

UNIT	A max.	A <sub>1</sub>	A <sub>2</sub>	A <sub>3</sub>	b <sub>p</sub>	c	D <sup>(1)</sup>	E <sup>(1)</sup>	e	H <sub>D</sub>	H <sub>E</sub>	L	L <sub>p</sub>	v	w	y	Z <sub>D</sub> <sup>(1)</sup>	Z <sub>E</sub> <sup>(1)</sup>	θ
mm	3.00	0.25 0.10	2.75 2.55	0.25	0.45 0.30	0.23 0.13	14.1 13.9	14.1 13.9	0.8	17.45 16.95	17.45 16.95	1.60	1.03 0.73	0.16	0.16	0.10	1.2 0.8	1.2 0.8	7° 0°

Note

1. Plastic or metal protrusions of 0.25 mm maximum per side are not included.

OUTLINE VERSION	REFERENCES				EUROPEAN PROJECTION	ISSUE DATE
	IEC	JEDEC	EIAJ			
SOT393-1		MS-022				97-08-04 99-12-27

## Digital TV Sound Processor (DTVSP)

## TDA9875A

### 14 SOLDERING

#### 14.1 Introduction

This text gives a very brief insight to a complex technology. A more in-depth account of soldering ICs can be found in our "Data Handbook IC26; Integrated Circuit Packages" (document order number 9398 652 90011).

There is no soldering method that is ideal for all IC packages. Wave soldering is often preferred when through-hole and surface mount components are mixed on one printed-circuit board. However, wave soldering is not always suitable for surface mount ICs, or for printed-circuit boards with high population densities. In these situations reflow soldering is often used.

#### 14.2 Through-hole mount packages

##### 14.2.1 SOLDERING BY DIPPING OR BY SOLDER WAVE

The maximum permissible temperature of the solder is 260 °C; solder at this temperature must not be in contact with the joints for more than 5 seconds. The total contact time of successive solder waves must not exceed 5 seconds.

The device may be mounted up to the seating plane, but the temperature of the plastic body must not exceed the specified maximum storage temperature ( $T_{stg(max)}$ ). If the printed-circuit board has been pre-heated, forced cooling may be necessary immediately after soldering to keep the temperature within the permissible limit.

##### 14.2.2 MANUAL SOLDERING

Apply the soldering iron (24 V or less) to the lead(s) of the package, either below the seating plane or not more than 2 mm above it. If the temperature of the soldering iron bit is less than 300 °C it may remain in contact for up to 10 seconds. If the bit temperature is between 300 and 400 °C, contact may be up to 5 seconds.

#### 14.3 Surface mount packages

##### 14.3.1 REFLOW SOLDERING

Reflow soldering requires solder paste (a suspension of fine solder particles, flux and binding agent) to be applied to the printed-circuit board by screen printing, stencilling or pressure-syringe dispensing before package placement.

Several methods exist for reflowing; for example, infrared/convection heating in a conveyor type oven. Throughput times (preheating, soldering and cooling) vary between 100 and 200 seconds depending on heating method.

Typical reflow peak temperatures range from 215 to 250 °C. The top-surface temperature of the packages should preferably be kept below 230 °C.

##### 14.3.2 WAVE SOLDERING

Conventional single wave soldering is not recommended for surface mount devices (SMDs) or printed-circuit boards with a high component density, as solder bridging and non-wetting can present major problems.

To overcome these problems the double-wave soldering method was specifically developed.

If wave soldering is used the following conditions must be observed for optimal results:

- Use a double-wave soldering method comprising a turbulent wave with high upward pressure followed by a smooth laminar wave.
- For packages with leads on two sides and a pitch (e):
  - larger than or equal to 1.27 mm, the footprint longitudinal axis is **preferred** to be parallel to the transport direction of the printed-circuit board;
  - smaller than 1.27 mm, the footprint longitudinal axis **must** be parallel to the transport direction of the printed-circuit board.

The footprint must incorporate solder thieves at the downstream end.

- For packages with leads on four sides, the footprint must be placed at a 45° angle to the transport direction of the printed-circuit board. The footprint must incorporate solder thieves downstream and at the side corners.

During placement and before soldering, the package must be fixed with a droplet of adhesive. The adhesive can be applied by screen printing, pin transfer or syringe dispensing. The package can be soldered after the adhesive is cured.

Typical dwell time is 4 seconds at 250 °C.

A mildly-activated flux will eliminate the need for removal of corrosive residues in most applications.

##### 14.3.3 MANUAL SOLDERING

Fix the component by first soldering two diagonally-opposite end leads. Use a low voltage (24 V or less) soldering iron applied to the flat part of the lead. Contact time must be limited to 10 seconds at up to 300 °C.

When using a dedicated tool, all other leads can be soldered in one operation within 2 to 5 seconds between 270 and 320 °C.

## Digital TV Sound Processor (DTVSP)

## TDA9875A

## 14.4 Suitability of IC packages for wave, reflow and dipping soldering methods

MOUNTING	PACKAGE	SOLDERING METHOD		
		WAVE	REFLOW <sup>(1)</sup>	DIPPING
Through-hole mount	DBS, DIP, HDIP, SDIP, SIL	suitable <sup>(2)</sup>	–	suitable
Surface mount	BGA, SQFP	not suitable	suitable	–
	HLQFP, HSQFP, HSOP, HTQFP, HTSSOP, SMS	not suitable <sup>(3)</sup>	suitable	–
	PLCC <sup>(4)</sup> , SO, SOJ	suitable	suitable	–
	LQFP, QFP, TQFP	not recommended <sup>(4)(5)</sup>	suitable	–
	SSOP, TSSOP, VSO	not recommended <sup>(6)</sup>	suitable	–

## Notes

1. All surface mount (SMD) packages are moisture sensitive. Depending upon the moisture content, the maximum temperature (with respect to time) and body size of the package, there is a risk that internal or external package cracks may occur due to vaporization of the moisture in them (the so called popcorn effect). For details, refer to the Drypack information in the "Data Handbook IC26; Integrated Circuit Packages; Section: Packing Methods".
2. For SDIP packages, the longitudinal axis must be parallel to the transport direction of the printed-circuit board.
3. These packages are not suitable for wave soldering as a solder joint between the printed-circuit board and heatsink (at bottom version) can not be achieved, and as solder may stick to the heatsink (on top version).
4. If wave soldering is considered, then the package must be placed at a 45° angle to the solder wave direction. The package footprint must incorporate solder thieves downstream and at the side corners.
5. Wave soldering is only suitable for LQFP, QFP and TQFP packages with a pitch (e) equal to or larger than 0.8 mm; it is definitely not suitable for packages with a pitch (e) equal to or smaller than 0.65 mm.
6. Wave soldering is only suitable for SSOP and TSSOP packages with a pitch (e) equal to or larger than 0.65 mm; it is definitely not suitable for packages with a pitch (e) equal to or smaller than 0.5 mm.

## Digital TV Sound Processor (DTVSP)

TDA9875A

**15 DEFINITIONS**

<b>Data sheet status</b>	
Objective specification	This data sheet contains target or goal specifications for product development.
Preliminary specification	This data sheet contains preliminary data; supplementary data may be published later.
Product specification	This data sheet contains final product specifications.
<b>Limiting values</b>	
Limiting values given are in accordance with the Absolute Maximum Rating System (IEC 134). Stress above one or more of the limiting values may cause permanent damage to the device. These are stress ratings only and operation of the device at these or at any other conditions above those given in the Characteristics sections of the specification is not implied. Exposure to limiting values for extended periods may affect device reliability.	
<b>Application information</b>	
Where application information is given, it is advisory and does not form part of the specification.	

**16 LIFE SUPPORT APPLICATIONS**

These products are not designed for use in life support appliances, devices, or systems where malfunction of these products can reasonably be expected to result in personal injury. Philips customers using or selling these products for use in such applications do so at their own risk and agree to fully indemnify Philips for any damages resulting from such improper use or sale.

**17 PURCHASE OF PHILIPS I<sup>2</sup>C COMPONENTS**

Purchase of Philips I<sup>2</sup>C components conveys a license under the Philips' I<sup>2</sup>C patent to use the components in the I<sup>2</sup>C system provided the system conforms to the I<sup>2</sup>C specification defined by Philips. This specification can be ordered using the code 9398 393 40011.

# Philips Semiconductors – a worldwide company

**Argentina:** see South America

**Australia:** 3 Figtree Drive, HOMEBUSH, NSW 2140,  
Tel. +61 2 9704 8141, Fax. +61 2 9704 8139

**Austria:** Computerstr. 6, A-1101 WIEN, P.O. Box 213,  
Tel. +43 1 60 101 1248, Fax. +43 1 60 101 1210

**Belarus:** Hotel Minsk Business Center, Bld. 3, r. 1211, Volodarski Str. 6,  
220050 MINSK, Tel. +375 172 20 0733, Fax. +375 172 20 0773

**Belgium:** see The Netherlands

**Brazil:** see South America

**Bulgaria:** Philips Bulgaria Ltd., Energoproject, 15th floor,  
51 James Bourchier Blvd., 1407 SOFIA,  
Tel. +359 2 68 9211, Fax. +359 2 68 9102

**Canada:** PHILIPS SEMICONDUCTORS/COMPONENTS,  
Tel. +1 800 234 7381, Fax. +1 800 943 0087

**China/Hong Kong:** 501 Hong Kong Industrial Technology Centre,  
72 Tat Chee Avenue, Kowloon Tong, HONG KONG,  
Tel. +852 2319 7888, Fax. +852 2319 7700

**Colombia:** see South America

**Czech Republic:** see Austria

**Denmark:** Sydhavnsgade 23, 1780 COPENHAGEN V,  
Tel. +45 33 29 3333, Fax. +45 33 29 3905

**Finland:** Sinikalliontie 3, FIN-02630 ESPOO,  
Tel. +358 9 615 800, Fax. +358 9 6158 0920

**France:** 51 Rue Carnot, BP317, 92156 SURESNES Cedex,  
Tel. +33 1 4099 6161, Fax. +33 1 4099 6427

**Germany:** Hammerbrookstraße 69, D-20097 HAMBURG,  
Tel. +49 40 2353 60, Fax. +49 40 2353 6300

**Hungary:** see Austria

**India:** Philips INDIA Ltd, Band Box Building, 2nd floor,  
254-D, Dr. Annie Besant Road, Worli, MUMBAI 400 025,  
Tel. +91 22 493 8541, Fax. +91 22 493 0966

**Indonesia:** PT Philips Development Corporation, Semiconductors Division,  
Gedung Philips, Jl. Buncit Raya Kav.99-100, JAKARTA 12510,  
Tel. +62 21 794 0040 ext. 2501, Fax. +62 21 794 0080

**Ireland:** Newstead, Clonskeagh, DUBLIN 14,  
Tel. +353 1 7640 000, Fax. +353 1 7640 200

**Israel:** RAPAC Electronics, 7 Kehilat Saloniki St, PO Box 18053,  
TEL AVIV 61180, Tel. +972 3 645 0444, Fax. +972 3 649 1007

**Italy:** PHILIPS SEMICONDUCTORS, Via Casati, 23 - 20052 MONZA (MI),  
Tel. +39 039 203 6838, Fax +39 039 203 6800

**Japan:** Philips Bldg 13-37, Kohnan 2-chome, Minato-ku,  
TOKYO 108-8507, Tel. +81 3 3740 5130, Fax. +81 3 3740 5057

**Korea:** Philips House, 260-199 Itaewon-dong, Yongsan-ku, SEOUL,  
Tel. +82 2 709 1412, Fax. +82 2 709 1415

**Malaysia:** No. 76 Jalan Universiti, 46200 PETALING JAYA, SELANGOR,  
Tel. +60 3 750 5214, Fax. +60 3 757 4880

**Mexico:** 5900 Gateway East, Suite 200, EL PASO, TEXAS 79905,  
Tel. +9-5 800 234 7381, Fax +9-5 800 943 0087

**Middle East:** see Italy

**Netherlands:** Postbus 90050, 5600 PB EINDHOVEN, Bldg. VB,  
Tel. +31 40 27 82785, Fax. +31 40 27 88399

**New Zealand:** 2 Wagener Place, C.P.O. Box 1041, AUCKLAND,  
Tel. +64 9 849 4160, Fax. +64 9 849 7811

**Norway:** Box 1, Manglerud 0612, OSLO,  
Tel. +47 22 74 8000, Fax. +47 22 74 8341

**Pakistan:** see Singapore

**Philippines:** Philips Semiconductors Philippines Inc.,  
106 Valero St. Salcedo Village, P.O. Box 2108 MCC, MAKATI,  
Metro MANILA, Tel. +63 2 816 6380, Fax. +63 2 817 3474

**Poland:** Al.Jerozolimskie 195 B, 02-222 WARSAW,  
Tel. +48 22 5710 000, Fax. +48 22 5710 001

**Portugal:** see Spain

**Romania:** see Italy

**Russia:** Philips Russia, Ul. Usatcheva 35A, 119048 MOSCOW,  
Tel. +7 095 755 6918, Fax. +7 095 755 6919

**Singapore:** Lorong 1, Toa Payoh, SINGAPORE 319762,  
Tel. +65 350 2538, Fax. +65 251 6500

**Slovakia:** see Austria

**Slovenia:** see Italy

**South Africa:** S.A. PHILIPS Pty Ltd., 195-215 Main Road Martindale,  
2092 JOHANNESBURG, P.O. Box 58088 Newville 2114,  
Tel. +27 11 471 5401, Fax. +27 11 471 5398

**South America:** Al. Vicente Pinzon, 173, 6th floor,  
04547-130 SÃO PAULO, SP, Brazil,  
Tel. +55 11 821 2333, Fax. +55 11 821 2382

**Spain:** Balmes 22, 08007 BARCELONA,  
Tel. +34 93 301 6312, Fax. +34 93 301 4107

**Sweden:** Kottbygatan 7, Akalla, S-16485 STOCKHOLM,  
Tel. +46 8 5985 2000, Fax. +46 8 5985 2745

**Switzerland:** Allmendstrasse 140, CH-8027 ZÜRICH,  
Tel. +41 1 488 2741 Fax. +41 1 488 3263

**Taiwan:** Philips Semiconductors, 6F, No. 96, Chien Kuo N. Rd., Sec. 1,  
TAIPEI, Taiwan Tel. +886 2 2134 2886, Fax. +886 2 2134 2874

**Thailand:** PHILIPS ELECTRONICS (THAILAND) Ltd.,  
209/2 Sanpavuth-Bangna Road Prakanong, BANGKOK 10260,  
Tel. +66 2 745 4090, Fax. +66 2 398 0793

**Turkey:** Yukari Dudullu, Org. San. Blg., 2.Cad. Nr. 28 81260 Umraniye,  
ISTANBUL, Tel. +90 216 522 1500, Fax. +90 216 522 1813

**Ukraine:** PHILIPS UKRAINE, 4 Patrice Lumumba str., Building B, Floor 7,  
252042 KIEV, Tel. +380 44 264 2776, Fax. +380 44 268 0461

**United Kingdom:** Philips Semiconductors Ltd., 276 Bath Road, Hayes,  
MIDDLESEX UB3 5BX, Tel. +44 208 730 5000, Fax. +44 208 754 8421

**United States:** 811 East Arques Avenue, SUNNYVALE, CA 94088-3409,  
Tel. +1 800 234 7381, Fax. +1 800 943 0087

**Uruguay:** see South America

**Vietnam:** see Singapore

**Yugoslavia:** PHILIPS, Trg N. Pasica 5/v, 11000 BEOGRAD,  
Tel. +381 11 62 5344, Fax. +381 11 63 5777

**For all other countries apply to:** Philips Semiconductors,  
International Marketing & Sales Communications, Building BE-p, P.O. Box 218,  
5600 MD EINDHOVEN, The Netherlands, Fax. +31 40 27 24825

**Internet:** <http://www.semiconductors.philips.com>

© Philips Electronics N.V. 1999

SCA 68

All rights are reserved. Reproduction in whole or in part is prohibited without the prior written consent of the copyright owner.

The information presented in this document does not form part of any quotation or contract, is believed to be accurate and reliable and may be changed without notice. No liability will be accepted by the publisher for any consequence of its use. Publication thereof does not convey nor imply any license under patent- or other industrial or intellectual property rights.

Printed in The Netherlands

545004/02/pp96

Date of release: 1999 Dec 20

Document order number: 9397 750 06065

*Let's make things better.*

Philips



PHILIPS