

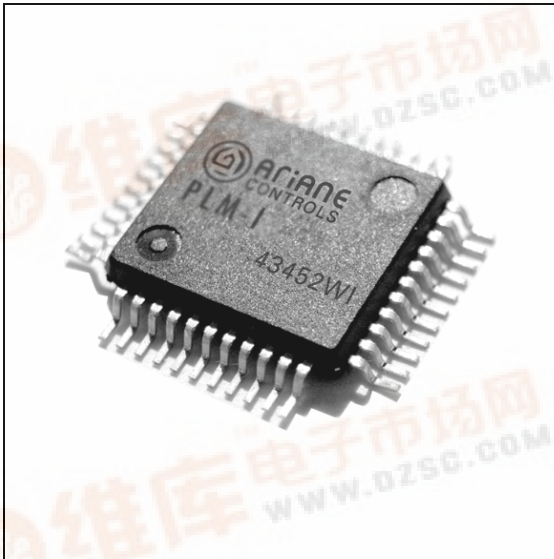

DATA SHEET

AC-PLM-1 Powerline Modem

DS01052 - January 2005 Revision March 2005



Features

- Very robust FSK demodulation technique, high noise immunity,
- Low-harmonic narrowband modulation
- Programmable baud rate from 100 bauds to 30,000 bauds
- Programmable carrier central frequency from 50 to 500 kHz
- Complete Medium Access Controls (MAC) logic on the device which can be disabled and implemented into the host to allow a better desired control
- CSMA/CD type collision detection and resolution
- Programmable packet-priority management with four levels (highest, high, standard and deferred)
- Packet queuing function
- Error detection (CRC 16)
- High-efficiency Forward Error Correction (FEC)
- Efficient nibble-oriented data encoding/decoding
- Full transaction-type management using unacknowledged and acknowledged messages
- General timer used for delay timing of retransmission, duplicate packet rejection
- Parallel and serial interface port (SPI compliant)
- Protocol neutrality, transports any high-level protocol packet (known or user-defined protocols) in a single network

Overview

The AC-PLM-1 ASIC is a single-chip digital modem implementing a half-duplex transmitter/receiver function to interface between a host and the power line. Using either a SPI or Parallel port, a host device is capable of sending and/or receiving information or commands to any other device connected to the power line. The modem includes a complete set of high-level functions, enabling designers to easily implement high-performance power line communication networks. The host can be any microcontroller with an SPI port or any computer with a parallel port.



Communication media

The AC-PLM-1 offers the possibility to transport any communication data over AC power line, DC line or twisted pair i.e. dedicated lines. This offers the possibility to link multiple existing networks.

Flexibility

The use of the AC-PLM-1 provides a lot of flexibility to your system. Based on the clock frequency, the baud rate and the carrier frequency, a number of parameters will be calculated using our tool. Those calculated parameters are used to configure the AC-PLM-1. After each soft or hard reset, the AC-PLM-1 expects to receive that string of parameters via its communication port. The CFGD pin indicates that the configuration string has been received with no error.

Host

Being SPI compliant, the communication port of the AC-PLM-1 can be linked to any micro-controller the application requires. The same communication port allows any PC to receive any command from the AC-PLM-1.

The following table shows the functionality of the Communication port pins based on the status of the PORTYPE pin:

PIN	PORTYPE	
	Serial (0)	Parallel (1)
PORT0	PDAV	DIO0/PDAV
PORT1	LBUSY	DIO1/LBUSY
PORT2	PBUSY	DIO2/PBUSY
PORT3	SDI	DIO3
PORT4	SDO	DIO4
PORT5	PCKPOL	RW
PORT6	PCK	STR
PORT7	Chip Select	Chip Select

NOTE: The data from the transceiver is nibble-oriented. A complete byte will be received every two transmissions. An interrupt is generated when a nibble has been received by the AC-PLM-1.

External Components

Few components are necessary to complete the functionality of the device. An external clock is required. It can come from an oscillator or if a microcontroller is used, its clock circuitry can be used to clock the transceiver.

Since the transceiver is using low-harmonic narrowband modulation, a ceramic filter is necessary to remove the out-of-band frequencies. Ariane Controls can provide you this component based on the central frequency chosen by your design team.

Applications

The Ariane Controls PLM-1 chip is a type B technology used in cost - sensitive, medium baud rate applications.

Utilities:

- Automatic Meter Reading (AMR)
- Remote Display
- Load Shedding
- Remote Diagnostic
- Street Light Monitoring

Building Automation:

- Light Switches
- Wall Outlets
- Thermostats/HVAC
- Clocks
- Sensors
- Alarm/Security
- People Care
- Access Controls

④ Transceiver Block Diagram

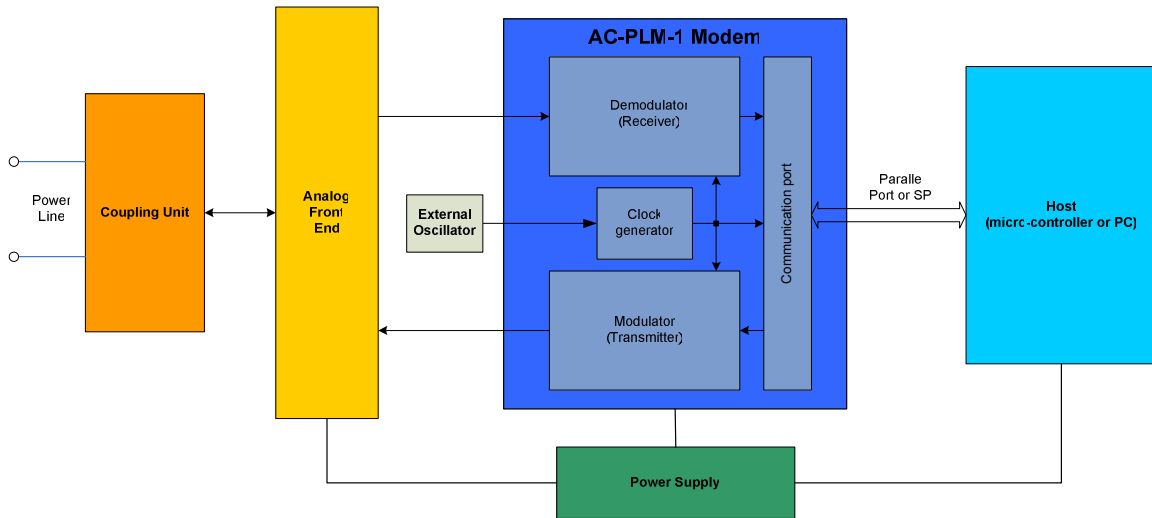

The external circuit diagrams can be provided upon request.

④ AC-PLM-1 Modem Pinout Diagram

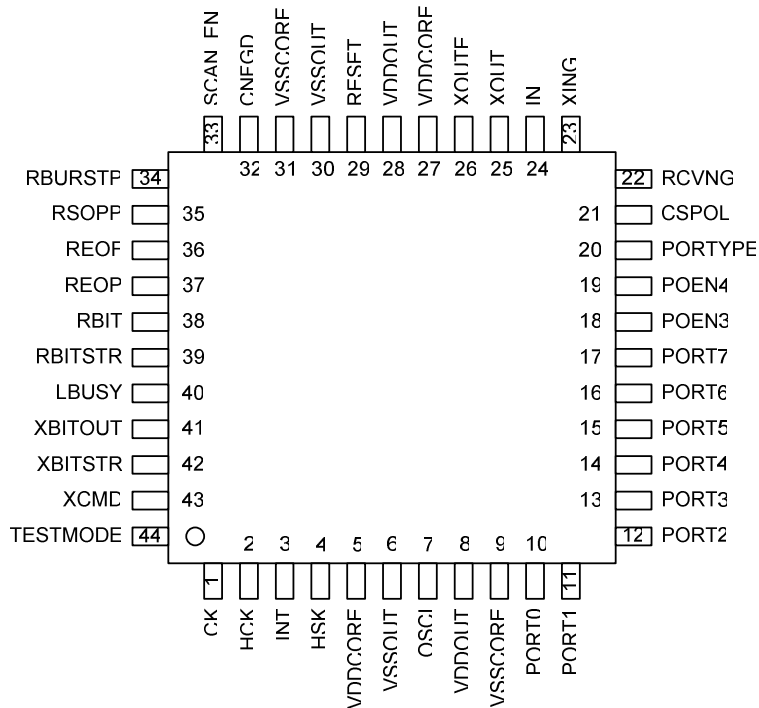

AC-PLM-1 Modem Pin Descriptions

Pin Name	Type	Pin No.	Drive (mA)	Functions
CK	Output	1	1	Frequency carrier = OSCI/XDVI.
HCK	Output	2	1	OSCI clock output.
INT ²	Output	3	2	Interrupt.
HSK ²	Tri-state	4	2	Handshake signal.
VDDCORE	VCC	5,27	-	3.3V input.
VSSOUT	GND	6,30	-	Ground signal.
OSCI	Input	7	-	Input clock signal.
VDDOUT	VCC	8,28	-	3.3V input.
VSSCORE	GND	9,31	-	Ground signal.
PORT0 ^{1,2}	Inout	10	2	Data IO 0 / Data available on the communication port.
PORT1 ^{1,2}	Inout	11	2	Data IO 1 / Line busy indication.
PORT2 ^{1,2}	Inout	12	2	Data IO 2 / Communication port busy indication.
PORT3 ^{1,2}	Inout	13	2	Data IO 3 / Serial data in (SDI).
PORT4 ^{1,2}	Inout	14	2	Data IO 4 / Serial data out (SDO).
PORT5 ^{1,2}	Input	15	-	Clock polarity in serial mode / read-write enable in parallel mode. Read = 1'b1.
PORT6 ^{1,2}	Input	16	-	Strobe or clock signal.
PORT7 ^{1,2}	Input	17	-	Chip Select.
POEN3 ²	Output	18	2	Port output enable for PORT3. Output when POEN3 = 1.
POEN4 ²	Output	19	2	Port output enable for PORT0, 1, 2 and 4. Output when POEN4 = 1.
PORTYPE ^{1,2}	Input	20	-	Communication port type. 1 = Parallel, 0 = serial.
CSPOL ^{1,2}	Input	21	-	Chip Select polarity. 1 = CS active high.
RCVNG	Output	22	8	Receiving a valid packet. Can drive a LED. Active low.
XING	Output	23	8	Transmitting a valid packet. Can drive a LED. Active low.
IN ²	Input	24	-	Receiver input.
XOUT ²	Output	25	1	Transmitter output. Need to be filtered to eliminate second frequency generated by the chip.
XOUTE ²	Output	26	1	Amplifier enable signal.
RESET	Output	29	-	Hardware reset. Active low. Internal pull-up.
CNFGD	Output	32	-	Configuration status. Active high. Can drive a LED.
SCAN_EN ³	Input	33	-	Use to internal test. Internal pull-down. Must be tied to GND.
RBURSTP	Output	34	1	DEBUG pin. Receiver burst pulse. No connect.
RSOPP	Output	35	1	DEBUG pin. Receiver side. Start of packet pulse. No connect.
REOF	Output	36	1	DEBUG pin. Receiver side. End of field. No connect.
REOP	Output	37	1	DEBUG pin. Receiver side. End of packet. No connect.
RBIT	Output	38	1	DEBUG pin. Receiver side. A bit of a packet.
RBITSTR	Output	39	1	DEBUG pin. Receiver side. Strobe to validate a RBIT.
LBUSY	Output	40	1	DEBUG pin. Line busy indicator.
XBITOUT	Output	41	1	DEBUG pin. TX side. Output bit before modulation.
XBITSTR	Output	42	1	DEBUG pin. TX side. Output bit strobe.
XCMD	Output	43	1	DEBUG pin. TX side. Command indicator.
TESTMODE	Output	44	1	Use by BIST test. Internal pull-down. Must be tied to GND.

1. This pin has a permanent pull-up of 50Kohms.

2. This pin is 5V Tolerant.

3. This pin has a permanent pull-down.

Ⓜ SPI Timing Diagram

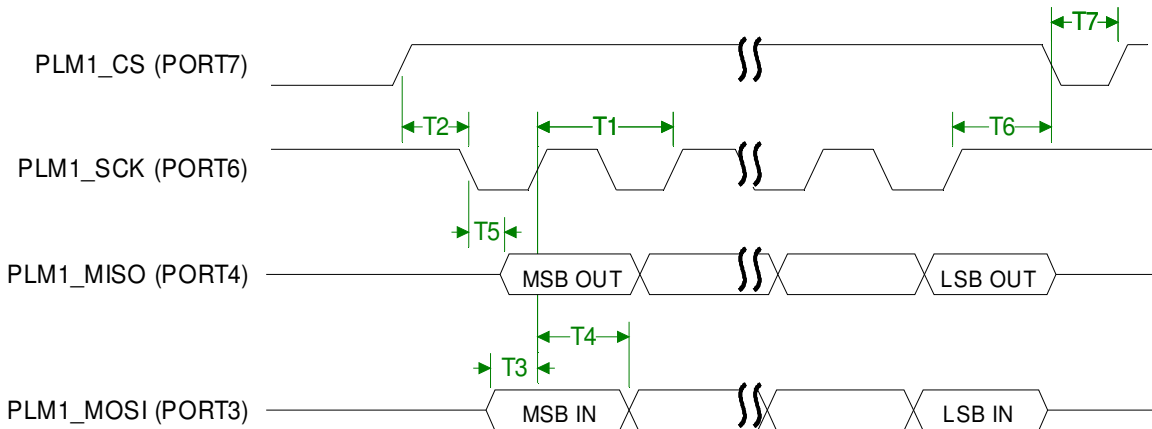

Num	Function	Min	Max	Unit
1	SCK period	4	32	t_{cyc}
2	Enable Time	4		t_{cyc}
3	Data Setup Time	30		ns
4	Data Hold Time	30		ns
5	Slave Access Time		2	t_{cyc}
6	Enable Log Time	2		t_{cyc}
7	Sequential Transfer Time	2		t_{cyc}

$$t_{cyc} = 1/f_{OSCI}$$

Ⓜ Operating Conditions

Symbol	Parameter	Min.	Typ.	Max.	Unit
V_{DDCORE}	Supply Voltage	3.0	3.3	3.6	V
V_{DDOUT}	Supply Voltage	3.0	3.3	3.6	V
OSCI	Clock frequency	4.0	6.144	20	MHz
F_{IN}	Baud rate = bandwidth of the ceramic filter @ -6dB	0.100	2.544	30	kHz
$F_{carrier}$	Carrier frequency, i.e. central frequency of the ceramic filter	50	262	500	kHz
T_A	Ambient Temperature	-40	25	85	°C

Ⓢ Electrical Specifications

Symbol	Parameter	Min.	Typ.	Max.	Unit
V _{IL}	Input Low-Level Voltage (3V TTL or 5V TTL Tolerant)	-	-	0.8	V
V _{IH}	Input High-Level Voltage (3V TTL or 5V TTL Tolerant)	2.0	-	-	V
V _{OL}	Output Low-Level Voltage	-	-	0.4	V
V _{OH}	Output High-Level Voltage	2.4	-	-	V

Ⓢ Absolute Maximum Ratings

Ambient operating temperature	-40 to 85°C
Storage Temperature	-55 to 125°C
Junction Temperature	88°C
Power dissipation	33 mW
The maximum DC current source by any VDD or VSS pin	±28 mA
Maximum Operating Frequency	20 MHz

Ⓢ AC-PLM-1 Modem Pad Layout

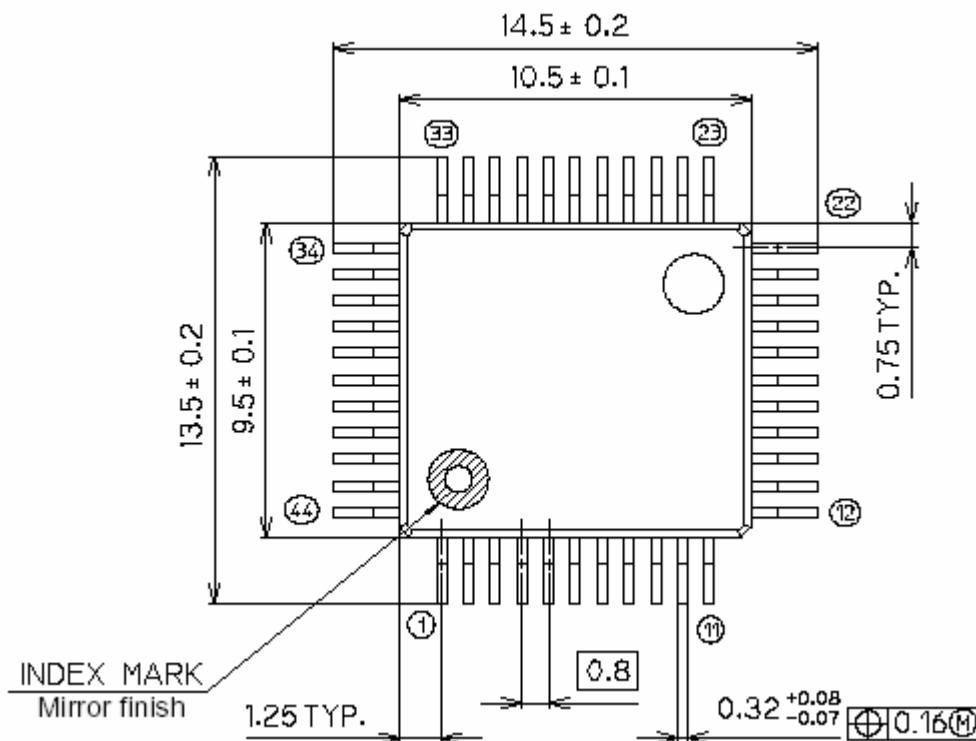

④ AC-PLM-1 Modem Package Diagram (POFP-44)

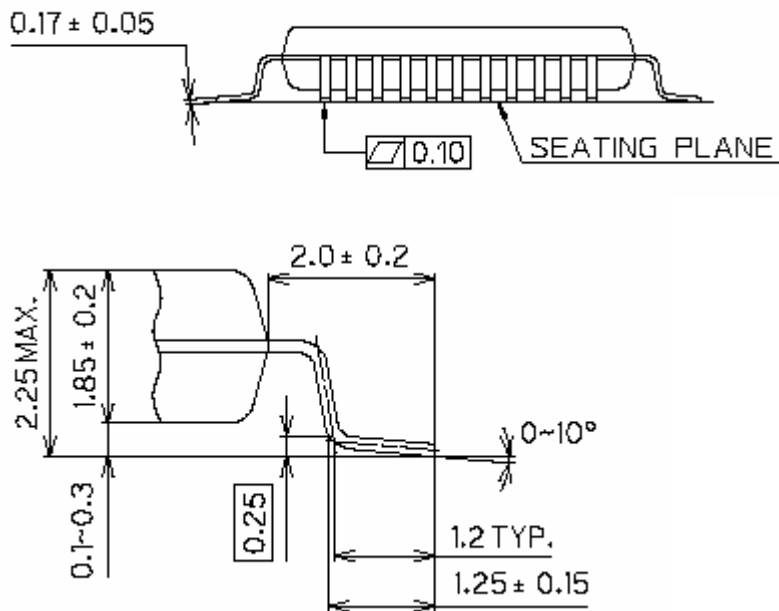

④ Ordering Information

Product number: AC-PLM-1
Contact: sales@arianecontrols.com

④ References

Web site: www.arianecontrols.com



4913 Lionel-Groulx, suite 22
Québec City, Québec
G3A 1V1 CANADA
Tel : +1 418 874 1919
Fax : +1 418 872 4348