



# 2 Pair/1 Pair ETSI Compatible HDSL Analog Front End

## Preliminary Technical Data

## AD5011

### FEATURES

- Integrated front End for Single Pair or Two Pair HDSL Systems
- Meets ETSI Specifications
- Supports 1168 kbps and 2.32 Mbps
- Programmable Filtering Supports Adaptive HDSL Transmit and Receive Signal Path Functions
- Receive Hybrid Amplifier, PGA, ADC and Adaptable Filter
- Transmit DAC, Adaptable Filter and Differential Outputs
- Normal Loopback
- Serial Interface to Digital Transceivers
- Single 3 V Power Supply

### GENERAL DESCRIPTION

The AD5011 is an analog front end for two pair or single pair HDSL applications that use 1168 kbps or 2.32 Mbps data rates. The device integrates all the transmit and receive functional blocks. A standard serial interface is used to communicate with the DAC and ADC. The filters in both the transmit and receive paths are programmable which allows adaptive HDSL to be performed also. The part is available in a 48-pin LQFP package and is specified for a temperature range of -40 °C to +85 °C.

### FUNCTIONAL BLOCK DIAGRAM

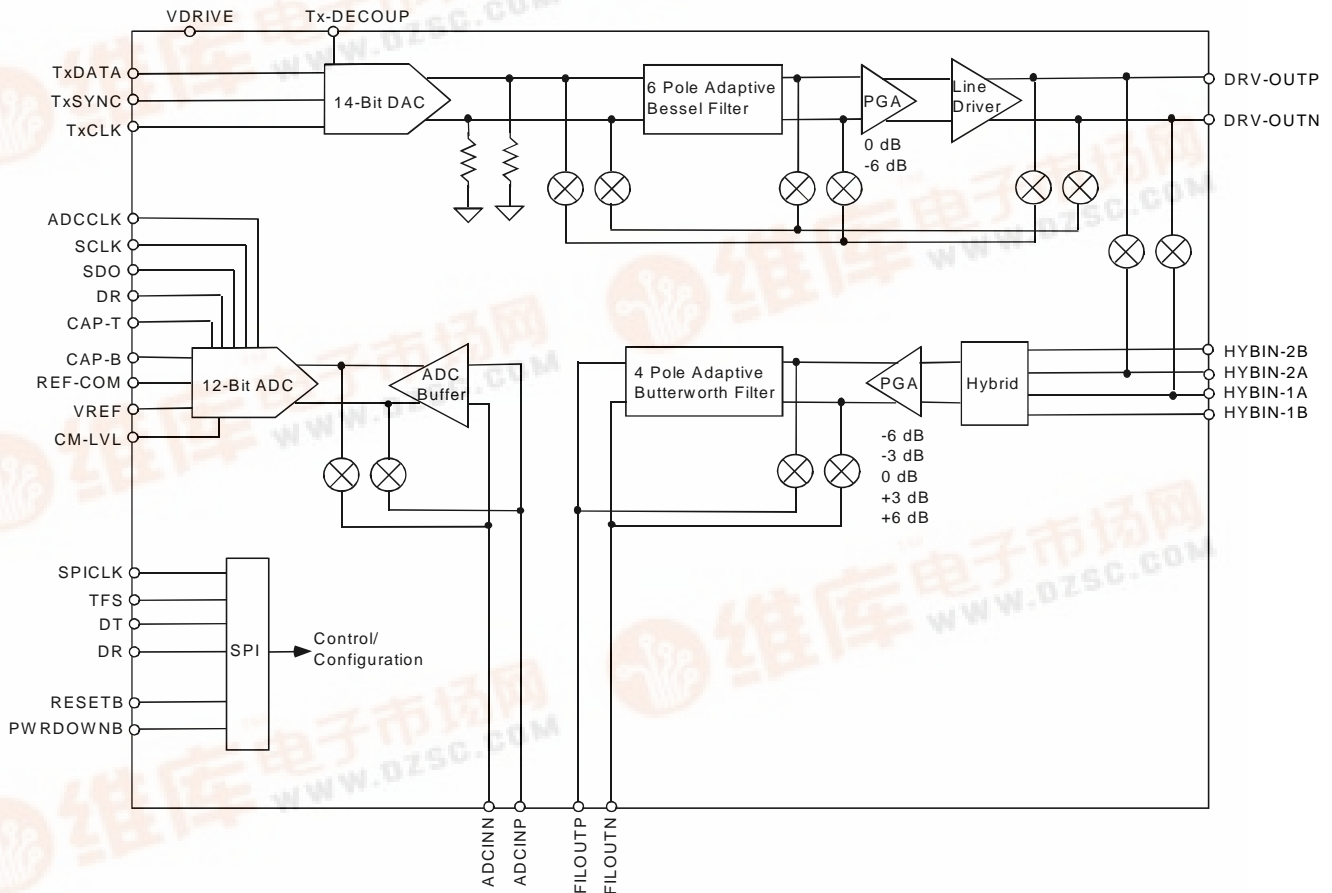

Information furnished by Analog Devices is believed to be accurate and reliable. However, no responsibility is assumed by Analog Devices for its use, nor for any infringements of patents or other rights of third parties which may result from its use. No license is granted by implication or otherwise under any patent or patent rights of Analog Devices.

# PRELIMINARY TECHNICAL DATA

## AD5011—SPECIFICATIONS<sup>1</sup>

( $V_{DD} = +3.15\text{ V to }+3.45\text{ V}$ ;  $AGND = DGND = 0\text{ V}$ ;  $T_A = T_{MIN}$  to  $T_{MAX}$  unless otherwise noted)

Parameter	AD5011B		Units	Test Conditions/Comments
	Min	Typ		
<b>TRANSMIT CHANNEL</b>				
Signal to Noise <sup>2</sup>	68	71	dB	$F_{OUT} = 73\text{ kHz}$
Total Harmonic Distortion <sup>2</sup>	66	71	dB	$F_{OUT} = 73\text{ kHz}$
<b>TRANSMIT DAC</b>				
Resolution		14	Bits	
Clock Frequency		18.688	MHz	
Coding		2s Complement		
Output Update Rate <sup>3</sup>		1168	kHz	
Output Voltage		1	V <sub>pp</sub> Diff	
<b>TRANSMIT FILTER</b>				
Cutoff Frequency <sup>4</sup>		49 - 120.8	kHz	Bottom Range (8 kHz steps)
		108 - 265	kHz	Mid Range (18 kHz steps)
		235 - 580	kHz	Top Range (40.5 kHz steps)
Corner Frequency Accuracy		±5	%	
Adjacent Corner Step		±40	% nom	
<b>LINE DRIVER<sup>5</sup></b>				
VCM		1.5	V	
Common Mode Voltage Error		±100	mV	
Output Power		13.5	dBm	
Output Voltage		4	V <sub>pp</sub> Diff	Tx-GAIN = 0
		2	V <sub>pp</sub> Diff	Tx-GAIN = 1
Channel Gain Accuracy		±1	dB	
<b>RECEIVE CHANNEL</b>				
Signal to (Noise + Distortion) <sup>6</sup>	66	68	dB	$F_{IN} = 73\text{ kHz}$
Total Harmonic Distortion	68	71	dB	$F_{IN} = 73\text{ kHz}$
<b>HYBRID INTERFACE</b>				
Input Voltage Range			5	V <sub>pp</sub> Diff
Common Mode Input Voltage		1.5	V	PGA = 0 dB
Input Impedance		10	k $\omega$	
Input Offset Voltage		80	mV	PGA = 0 dB
<b>PROGRAMMABLE GAIN AMPLIFIER<sup>7</sup></b>				
Overall Gain Accuracy		±1	dB	For all Gain Settings from -6 dB to +9 dB
Gain Step		3	dB	
Gain Step Accuracy		±0.25	dB	
<b>RECEIVE FILTER</b>				
Cutoff Frequency <sup>4</sup>		49 - 120.8	kHz	Bottom Range (8 kHz steps)
		108 - 265	kHz	Mid Range (18 kHz steps)
		235 - 580	kHz	Top Range (40.5 kHz steps)
Accuracy		±5	%	
Adjacent Corner Step		±40	% nom	
Output Load Capacitance			20	pF
Output Load Resistance		TBD	$\omega$	
<b>RECEIVE ADC</b>				
Resolution		12	Bits	
Coding		2s Complement		
Sample Rate		2.32	MHz	
<b>LOGIC INPUTS</b>				
Input Logic High, $V_{INH}$ <sup>8</sup>	2	3	V	
Input Logic Low, $V_{INL}$		0	0.2	V
$I_{IN}$ , Input Current			±10	mA
$C_{IN}$ , Input Capacitance			10	pF
				$V_{IN} = 0\text{ V to }DVDD$

# PRELIMINARY TECHNICAL DATA

AD5011

Parameter	AD7346B			Units	Test Conditions/Comments
	Min	Typ	Max		
LOGIC OUTPUTS					
Output Logic High, $V_{OH}$ <sup>9</sup>	VDD - 0.3			V	$I_{OUT} = 200\text{ mA}$
Output Logic Low, $V_{OL}$			0.3	V	$I_{OUT} = 200\text{ mA}$
POWER SUPPLIES					
AVDD, DVDD	3.15	3.3	3.45	V	
IDD					
Normal Mode (excluding Driver)		32		mA	
Line Driver		75		mA	33W Differential Load

<sup>1</sup>Operating temperature range is as follows: B Version:  $-40^{\circ}\text{C}$  to  $+85^{\circ}\text{C}$ .

<sup>2</sup>The complete transmit path spectrum and pulse shape comply with ETSI requirements. SNR and THD are measured within a 547 kHz bandwidth. Noise and Spurious tones beyond 540 kHz are therefore excluded.

<sup>3</sup>The transmit DAC maximum update rate is half the maximum output data rate i.e. 1168 kHz. The maximum transmit clock is  $16 \times 1168 = 18.688\text{ MHz}$ .

<sup>4</sup>There are three ranges (bottom range, mid range, top range), each range being divided into eight steps. The transmit filter corner frequency can be set independently from the receive filter corner frequency. The filter tuning circuit requires a continuous 16.384 MHz clock applied to the Fclk pin.

<sup>5</sup>Transformer turns ratio = 1:2:3 at 50 kHz when loaded by ETSI (RTR/TM3036) HDSL test loops.

<sup>6</sup>With 547 kHz filter and 0 dB PGA gain selected.

<sup>7</sup>The PGA gain is set by setting the PGA-GC bits in the control register.

<sup>8</sup>The input switching threshold voltage is approximately 1.2 V to allow interfacing to 2.5 V and 3.3 V logic.

<sup>9</sup>The output level is determined by the voltage on the logic supply pin  $V_{DRIVE}$ .

Specifications subject to change without notice.

# PRELIMINARY TECHNICAL DATA

## AD5011

### TIMING CHARACTERISTICS ( $V_{DD} = +2.7\text{ V to }+5.5\text{ V}$ ; $AGND = DGND = 0\text{ V}$ , unless otherwise noted)

Parameter	Limit at $T_{MIN}$ to $T_{MAX}$ (B Version)	Units	Test Conditions/Comments
<b>ADCCLK <math>\leq 1160\text{kHz}</math></b>			
$t_1$	$1.5 \cdot t_3$	ns min	ADCCLK Rising Edge to SCLK Rising Edge Delay
	$2 \cdot t_3$	ns typ	
$t_2$	$2.5 \cdot t_3$	ns min	SCLK Rising Edge to ADCCLK Falling Edge Delay
	$3 \cdot t_3$	ns typ	
$t_3$	26.939	ns min	SCLK Period ( $1/32 \cdot \text{ADCCLK Period}$ )
$t_4$	5	ns min	Data Setup Time Before SCLK Falling Edge
$t_5$	10	ns min	Data Hold Time After SCLK Falling Edge
<b>1160 kHz &lt; ADCCLK <math>\leq 2320\text{ kHz}</math></b>			
$t_6$	20	ns min	ADCCLK Rising Edge to SCLK Rising Edge Delay
	$1 \cdot t_8$	ns typ	
$t_7$	$1.5 \cdot t_8$	ns min	SCLK Rising Edge to ADCCLK Falling Edge Delay
	$2 \cdot t_8$	ns typ	
$t_8$	26.939	ns min	SCLK Period ( $1/16 \cdot \text{ADCCLK Period}$ )
$t_9$	5	ns min	Data Setup Time Before SCLK Falling Edge
$t_{10}$	10	ns min	Data Hold Time After SCLK Falling Edge
<b>TRANSMIT DAC</b>			
$t_{11}$	53.5	ns min	TxCLK Period ( $1/18.688\text{ MHz}$ )
$t_{12}$	12	ns min	Data Setup Time Before TxCLK Rising Edge
$t_{13}$	10	ns min	Data Hold Time After TxCLK Rising Edge
$t_{14}$	$t_{11}$	ns min	TxSYNC Low Time
$t_{15}$	3	ns min	TxCLK Rising Edge to TxSYNC Falling Edge Delay
		t11/2	ns max
<b>CONTROL REGISTER</b>			
$t_{16}$	50	ns min	SPICLK Period
	76	ns typ	
$t_{17}$	15	ns min	TFS Setup Time Before SPICLK Falling Edge
	$t_{16} - 15$	ns max	
$t_{18}$	15	ns min	TFS Hold Time After SPICLK Falling Edge
	$t_{16} - 15$	ns max	
$t_{19}$	$t_{16}$	ns typ	TFS High Time
$t_{20}$	7	ns min	DT Setup Time Before SPICLK Falling Edge
$t_{21}$	10	ns min	DT Hold Time After SPICLK Falling Edge
$t_{22}$	7	ns min	DR Setup Time Before SPICLK Falling Edge ( $R/\overline{W} = 1$ )
$t_{23}$	10	ns min	DR Hold Time After SPICLK Falling Edge ( $R/\overline{W} = 1$ )

Guaranteed by design but not production tested.

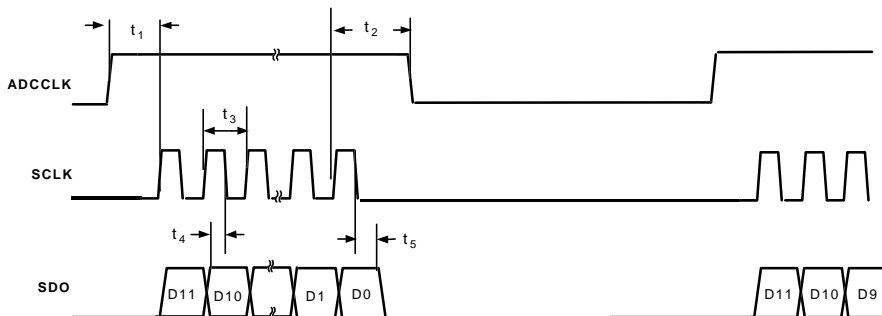

SCLK activity and serial output data activity does not coincide with the sensitive ADCCLK clock edges

Figure 1. ADC Timing (ADCCLK  $\leq 1160\text{ kHz}$ )

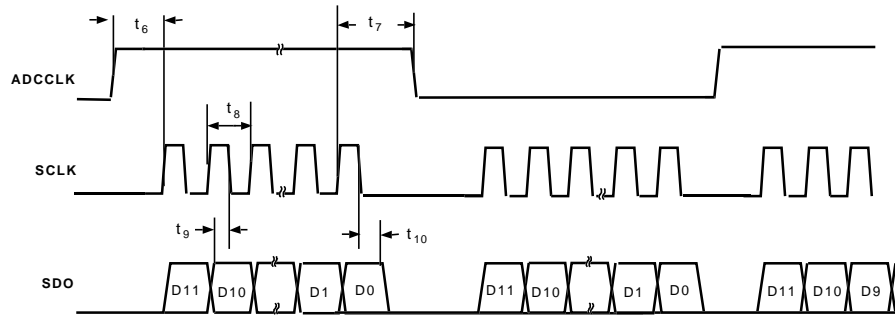

SCLK activity and serial output data activity does not coincide with the sensitive ADCCLK clock edges

Figure 2. ADC Timing ( $1160 \text{ kHz} < \text{ADCCLK} \leq 2320 \text{ kHz}$ )

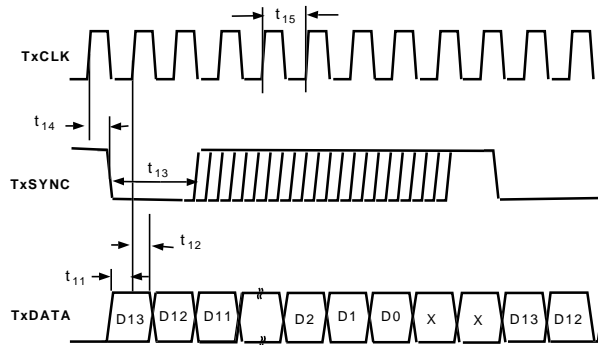

The rising edge of TxSYNC can occur anywhere as long as the TxSYNC low time exceeds one TxCLK period. The TxSYNC falling edge must occur after the TxCLK rising edge which captures the LSB of the previous word. This ensures correct loading into the DAC. The first 14 bits are loaded into the DAC, the 2 LSBs being don't cares.

Figure 3. DAC Timing

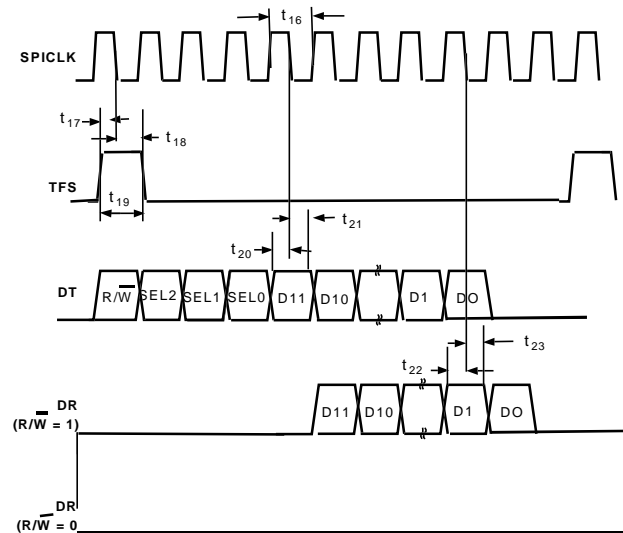

If  $R/\overline{W} = 1$ , the selected register's contents will be output on DR. If  $R/\overline{W} = 0$ , no data will be output on DR. The SEL bits identify which of the four register banks is being written to. The 12 LSBs contain the word. When the AD5011 is reset using RESETB, the registers are reset to zero.

Figure 4. Control Interface

# PRELIMINARY TECHNICAL DATA

## AD5011

### PIN DESCRIPTION

Mnemonic	Function
<b>POWER SUPPLY</b>	
VDRIVE	Digital output drive level.
AGND	Analog power supply.
AGND	Analog Ground.
DVDD	Positive power supply for the digital section.
DGND	Digital Ground.
<b>TRANSMIT CHANNEL</b>	
TxDATA	Transmit data input.
TxSYNC	Transmit data frame synchronization, logic input.
TxCLK	Transmit serial clock, logic input.
TxDECOUP	Transmit DAC reference decoupling pin. The reference which supplies the DAC needs some external decoupling.
DRV-OUTP	Differential line driver positive output.
DRV-OUTN	Differential line driver negative output.
<b>EXTERNAL INTERFACE</b>	
SPICLK	Serial interface clock, logic input.
TFS	Serial Interface frame synchronisation, logic input.
DT	Serial interface data input.
DR	Serial interface data output.
RESETB	Master Reset. This is an active low logic input.
PWRDWNB	Master powerdown. When PWRDWNB is taken low, the complete AD5011 device is placed in a sleep mode.
FCLK	Filter tuning clock. The clock for the filter tuning circuit in both the transmit and receive paths is supplied to FCLK. A 16.384 MHz should be connected to this pin to obtain the specified frequencies.
TEST	Test Mode. When TEST is tied to DVDD, the AD5011 is placed in a test mode. For normal operation, this pin should be tied to DGND.
<b>RECEIVE CHANNEL</b>	
HYBIN-2B	Hybrid non-inverting input.
HYBIN-2A	Hybrid inverting input.
HYBIN-1B	Hybrid inverting input.
HYBIN-1A	Hybrid non-inverting input.
FILTOUTP	Positive differential output of the antialiasing filter.
FILTOUTN	Negative differential output of the antialiasing filter.
ADCINP	Positive differential input to the ADC.
ADCINN	Negative differential input to the ADC.
CAP-T	Receive ADC reference decoupling pin. The reference which supplies the ADC needs some external decoupling.
CAP-B	Receive ADC reference decoupling pin. The reference which supplies the ADC needs some external decoupling.
VREF	Voltage Reference. The external reference is applied to this pin.
REF-COM	Reference common.
COM-LVL	Common mode level.
ADCCLK	ADC Sample clock, logic input. This clock also operates as the frame synchronization.
SCLK	ADC serial interface clock, logic input.
SDO	ADC serial data out.

# PRELIMINARY TECHNICAL DATA

AD5011

Table 1. Control Register

Serial Register	SEL[2:0]=000 Control Reg	SEL[2:0]=001 Tx Prog Filt Reg	SEL[2:0]=010 Rx Prog Filt Reg	SEL[2:0]=011 Test Purposes Only
D[15]	R/ $\overline{W}$ = 0	R/ $\overline{W}$ = 0	R/ $\overline{W}$ = 0	R/ $\overline{W}$ = 0
D[14]	SEL[2] = 0	SEL[2] = 0	SEL[2] = 0	SEL[2] = 0
D[13]	SEL[1] = 0	SEL[1] = 0	SEL[1] = 1	SEL[1] = 1
D[12]	SEL[0] = 0	SEL[0] = 1	SEL[0] = 0	SEL[0] = 1
D[11]	$\overline{PWDN-Tx}$	WRBOTH	WRBOTH	Reserved
D[10]	$\overline{PWDN-Rx}$	TPFD[10]	RPFD[10]	Reserved
D[9]	LOOPBACK	TPFD[9]	RPFD[9]	Reserved
D[8]	AA-BUF-BP	TFPD[8]	RPFD[8]	Reserved
D[7]	AA-FLTR-BP	TFPD[7]	RFPD[7]	Reserved
D[6]	Tx-GAIN-SEL	TFPD[6]	RFPD[6]	Reserved
D[5]	Tx-DACOUT	TFPD[5]	RFPD[5]	Reserved
D[4]	Tx-LPF-BP	TFPD[4]	RFPD[4]	Reserved
D[3]	Tx-DRVR-BP	TFPD[3]	RFPD[3]	Reserved
D[2]	PGA-GC2	TFPD[2]	RFPD[2]	Reserved
D[1]	PGA-GC1	TFPD[1]	RFPD[1]	Reserved
D[0]	PGA-GC0	TFPD[0]	RFPD[0]	Reserved

### Control Register Functions

Mnemonic	Function
R/ $\overline{W}$	When R/ $\overline{W}$ is high, the register bank addressed by SEL[2:0] is loaded into the output shift register. Serial data will subsequently be output onto the DR pin. If R/ $\overline{W}$ is low, the serial input data located at D[11:0] will be written into the register bank addressed by SEL[2:0].
$\overline{PWDN-Tx}$	When $\overline{PWDN-Tx}$ is low, the entire transmit channel is powered down. The line driver output is high impedance when the transmit channel is powered down.
$\overline{PWDN-Rx}$	When this bit is low, the entire receive channel is powered down.
LOOPBACK	When this bit is high, analog loopback is selected.
AA-BUF-BP	When this bit equals 1, the ADC buffer is bypassed.
AA-FLTR-BP	When this bit equals 1, the receive filter is bypassed.
Tx-GAIN-SEL	When Tx-GAIN-SEL equals 1, the output of the transmit filter is attenuated by 6 dB.
WRBOTH	The transmit and receive programmable filter corner frequencies are addressed by the 11-bit words TPFD and RPFD respectively. TPFD data is loaded from the serial input register to the transmit filter register if SEL[2:0] = 010. RPFD data is written to the receive filter register if SEL[2:0] = 010. If WRBOTH equals 1 during either of the above conditions, the word in the serial input register is loaded into both the TFPD and RFPD registers.

### Configuring the Transmit Channel

Tx-DACOUT	Tx-FILT-BP	Tx-DRVR-BP	Configuration
0	0	0	Default. All Components in the Tx channel are used.
1	0	0	The DAC output is seen at the line driver output pins. The line driver amplifier output is in a high impedance state.
0	1	0	The Tx filter is bypassed. The DACOUT is fed to the PGA. The filter amplifier output is in a high impedance state.
0	0	1	The filter output is seen at the line driver output pins. The line driver amplifier output is in a high impedance state.

# PRELIMINARY TECHNICAL DATA

AD5011

Programmable Gain Amplifier Gain Settings (Receive Signal)

GGA-GC2	PGA-GC1	PGA-GC0	Gain (dB)
0	0	0	-6
0	0	1	-3
0	1	0	0
0	1	1	3
1	0	0	6
1	0	1	9
1	1	0	9
1	1	1	9

Transmit and Receive Filter Corner Frequency (kHz)

TPFD [7:0] RPFd[0:7]	TPFD[8] RPFd[8]	TPFD[9] RPFd[9]	TPFD[10] RPFd[10]
TBD	49	108	235
TBD	52	114	250
TBD	59.8	131	287
TBD	67.5	148	324
TBD	75.3	165	361
TBD	83	182	399
TBD	90.8	199	436
TBD	98.5	216	473
TBD	106.3	233	510
TBD	114	250	547
TBD	120.8	265	580