

FEATURES

Dual channel

16-bit resolution: AD5547

14-bit resolution: AD5557

2- or 4-quadrant, 4 MHz BW multiplying DAC

± 1 LSB DNL

± 1 LSB INL for AD5557, ± 2 LSB INL for AD5547

Operating supply voltage: 2.7 V to 5.5 V

Low noise: 12 nV/ $\sqrt{\text{Hz}}$

Low power: $I_{DD} = 10 \mu\text{A}$ max

0.5 μs settling time

Built-in R_{FB} facilitates current-to-voltage conversion

Built-in 4-quadrant resistors allow 0 V to -10 V, 0 V to $+10$ V,
or ± 10 V outputs

2 mA full-scale current $\pm 20\%$, with $V_{REF} = 10$ V

Extended automotive operating temperature range:
 -40°C to $+125^\circ\text{C}$

Selectable zero-scale/midscale power-on presets

Compact TSSOP-38 package

APPLICATIONS

Automatic test equipment

Instrumentation

Digitally controlled calibration

Digital waveform generation

GENERAL DESCRIPTION

The AD5547/AD5557 are dual precision, 16-/14-bit, multiplying, low power, current-output, parallel input, digital-to-analog converters. They are designed to operate from single $+5$ V supply with ± 10 V multiplying references for 4-quadrant outputs with up to 4 MHz bandwidth.

FUNCTIONAL BLOCK DIAGRAM

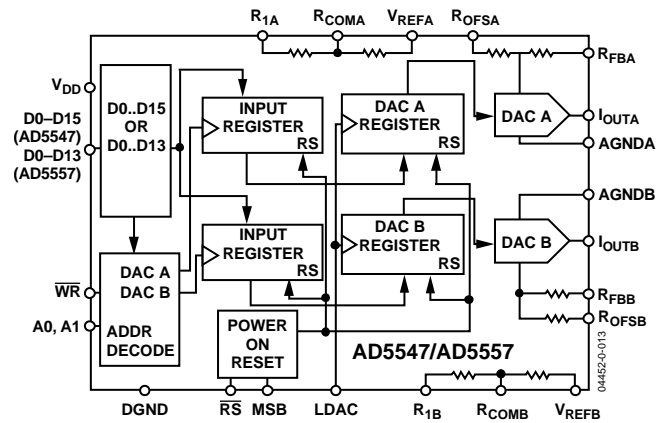

Figure 1.

The built-in 4-quadrant resistors facilitate resistance matching and temperature tracking, which minimize the numbers of components needed for multi-quadrant applications. In addition, the feedback resistor (R_{FB}) simplifies the I-V conversion with an external buffer.

The AD5547/AD5557 are available in a compact TSSOP-38 package and operate at the extended automotive temperature range of -40°C to $+125^\circ\text{C}$.

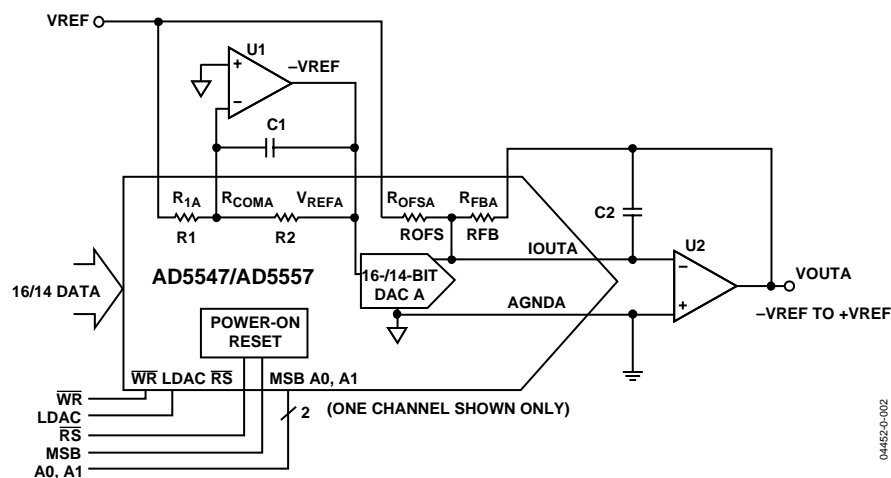

Figure 2. 16/14-Bit 4-Quadrant Multiplying DAC with Minimum of External Components (Only One Channel Shown)

Rev. 0

Information furnished by Analog Devices is believed to be accurate and reliable. However, no responsibility is assumed by Analog Devices for its use, nor for any infringements of patents or other rights of third parties that may result from its use. Specifications subject to change without notice. No license is granted by implication or otherwise under any patent or patent rights of Analog Devices. Trademarks and registered trademarks are the property of their respective owners.

TABLE OF CONTENTS

Specifications.....	3	PCB Layout, Power Supply Bypassing, and Ground Connections	13
Absolute Maximum Ratings.....	5	Applications.....	14
ESD Caution.....	5	Unipolar Mode	14
Pin Configurations and Function Descriptions	6	Bipolar Mode	16
Typical Performance Characteristics	9	Outline Dimensions	19
Circuit Operation	12	Ordering Guide	19
D/A Converter Section	12		
Digital Section.....	13		

REVISION HISTORY

Revision 0: Initial Version

SPECIFICATIONS

$V_{DD} = 2.7\text{ V to }5.5\text{ V}$, $I_{OUT} = \text{Virtual GND}$, $GND = 0\text{ V}$, $V_{REF} = -10\text{ V to }+10\text{ V}$, $T_A = -40^\circ\text{C to }+125^\circ\text{C}$, unless otherwise noted.

Table 1. Electrical Characteristics

Parameter	Symbol	Conditions	Min	Typ	Max	Unit
STATIC PERFORMANCE¹						
Resolution	N	AD5547, 1 LSB = $V_{REF}/2^{16} = 153\ \mu\text{V}$ at $V_{REF} = 10\text{ V}$ AD5557, 1 LSB = $V_{REF}/2^{14} = 610\ \mu\text{V}$ at $V_{REF} = 10\text{ V}$		16		Bits
Relative Accuracy	INL	Grade: AD5557C Grade: AD5547B			± 1	LSB
Differential Nonlinearity	DNL	Monotonic			± 1	LSB
Output Leakage Current	I_{OUT}	Data = zero scale, $T_A = 25^\circ\text{C}$ Data = zero scale, $T_A = T_A \text{ maximum}$			10	nA
Full-Scale Gain Error	G_{FSE}	Data = full scale		± 1	± 4	mV
Bipolar Mode Gain Error	G_E	Data = full scale		± 1	± 4	mV
Bipolar Mode Zero-Scale Error	G_{ZSE}	Data = full scale		± 1	± 3	mV
Full-Scale Tempco ²	TCV_{FS}			1		ppm/ $^\circ\text{C}$
REFERENCE INPUT						
V_{REF} Range	V_{REF}		-18		+18	V
REF Input Resistance	REF		4	5	6	k Ω
R1 and R2 Resistance	R1 and R2		4	5	6	k Ω
R1-to-R2 Mismatch	$\Delta(R1 \text{ to } R2)$			± 0.5	± 1.5	Ω
Feedback and Offset Resistance	R_{FB}, R_{OFS}		8	10	12	k Ω
Input Capacitance ²	C_{REF}			5		pF
ANALOG OUTPUT						
Output Current	I_{OUT}	Data = full scale		2		mA
Output Capacitance ²	C_{OUT}	Code dependent		200		pF
LOGIC INPUT AND OUTPUT						
Logic Input Low Voltage	V_{IL}	$V_{DD} = 5\text{ V}$ $V_{DD} = 3\text{ V}$			0.8 0.4	V
Logic Input High Voltage	V_{IH}	$V_{DD} = 5\text{ V}$ $V_{DD} = 3\text{ V}$	2.4 2.1			V
Input Leakage Current	I_{IL}				10	μA
Input Capacitance ²	C_{IL}				10	pF
INTERFACE TIMING^{2,3}						
Data to \overline{WR} Setup Time	t_{DS}	$V_{DD} = 5\text{ V}$ $V_{DD} = 3\text{ V}$	20 35			ns
Data to \overline{WR} Hold Time	t_{DH}	$V_{DD} = 5\text{ V}$ $V_{DD} = 3\text{ V}$	0 0			ns
\overline{WR} Pulse Width	$t_{\overline{WR}}$	$V_{DD} = 5\text{ V}$ $V_{DD} = 3\text{ V}$	20 35			ns
LDAC Pulse Width	t_{LDAC}	$V_{DD} = 5\text{ V}$ $V_{DD} = 3\text{ V}$	20 35			ns
\overline{RS} Pulse Width	t_{RS}	$V_{DD} = 5\text{ V}$ $V_{DD} = 3\text{ V}$	20 35			ns
\overline{WR} to LDAC Delay Time	t_{LWD}	$V_{DD} = 5\text{ V}$ $V_{DD} = 3\text{ V}$	0 0			ns
SUPPLY CHARACTERISTICS						
Power Supply Range	$V_{DD \text{ RANGE}}$		2.7		5.5	V
Positive Supply Current	I_{DD}	Logic inputs = 0 V			10	μA
Power Dissipation	P_{DISS}	Logic inputs = 0 V			0.055	mW
Power Supply Sensitivity	P_{SS}	$\Delta V_{DD} = \pm 5\%$			0.003	%/%

AD5547/AD5557

Parameter	Symbol	Conditions	Min	Typ	Max	Unit
AC CHARACTERISTICS ⁴						
Output Voltage Settling Time	t_s	To $\pm 0.1\%$ of full scale, data cycles from zero scale to full scale to zero scale		0.5		μs
Reference Multiplying BW	BW	$V_{REF} = 5 V$ p-p, data = full scale		4		MHz
DAC Glitch Impulse	Q	$V_{REF} = 0 V$, midscale to midscale - 1		7		nV-s
Multiplying Feedthrough Error	V_{OUT}/V_{REF}	$V_{REF} = 100 mV$ rms, $f = 10 kHz$		-65		dB
Digital Feedthrough	Q_D	$\overline{WR} = 1$, LDAC toggles at 1 MHz		7		nV-s
Total Harmonic Distortion	THD	$V_{REF} = 5 V$ p-p, data = full scale, $f = 1 kHz$		-85		dB
Output Noise Density	e_n	$f = 1 kHz$, BW = 1 Hz		12		nV/\sqrt{Hz}
Analog Crosstalk	C_{AT}	Signal input at Channel A and measure the output at Channel B, $f = 1 kHz$		-95		dB

¹ All static performance tests (except I_{OUT}) are performed in a closed-loop system using an external precision OP97 I-V converter amplifier. The device R_{FB} terminal is tied to the amplifier output. The OP97's +IN pin is grounded, and the DAC's I_{OUT} is tied to the OP97's -IN pin. Typical values represent average readings measured at 25°C.

² Guaranteed by design; not subject to production testing.

³ All input control signals are specified with $t_r = t_f = 2.5 ns$ (10% to 90% of 3 V), and are timed from a voltage level of 1.5 V.

⁴ All ac characteristic tests are performed in a closed-loop system using an AD841 I-V converter amplifier.

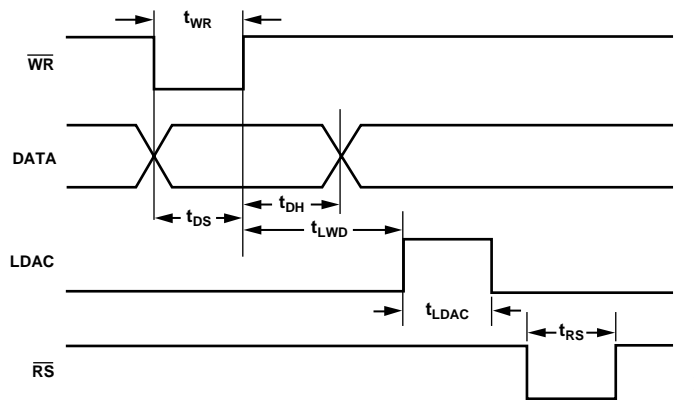

Figure 3. AD5547/AD5557 Timing Diagram

ABSOLUTE MAXIMUM RATINGS

Table 2.

Parameter	Rating
V _{DD} to GND	-0.3 V, +8 V
R _{FB} , R _{OF5} , R1, R _{COM} , and VREF to GND	-18 V, 18 V
Logic Inputs to GND	-0.3 V, +8 V
V(I _{OUT}) to GND	-0.3 V, V _{DD} + 0.3 V
Input Current to Any Pin except Supplies	±50 mA
Thermal Resistance (θ _{JA}) ¹	
Maximum Junction Temperature (T _{J MAX})	150°C
Operating Temperature Range	-40°C to +125°C
Storage Temperature Range	-65°C to +150°C
Lead Temperature	
Vapor Phase, 60 s	215°C
Infrared, 15 s	220°C

Stresses above those listed under Absolute Maximum Ratings may cause permanent damage to the device. This is a stress rating only; functional operation of the device at these or any other conditions above those listed in the operational sections of this specification is not implied. Exposure to absolute maximum rating conditions for extended periods may affect device reliability.

¹ Package power dissipation = (T_{J MAX} - T_A)/θ_{JA}.

ESD CAUTION

ESD (electrostatic discharge) sensitive device. Electrostatic charges as high as 4000 V readily accumulate on the human body and test equipment and can discharge without detection. Although this product features proprietary ESD protection circuitry, permanent damage may occur on devices subjected to high energy electrostatic discharges. Therefore, proper ESD precautions are recommended to avoid performance degradation or loss of functionality.



PIN CONFIGURATIONS AND FUNCTION DESCRIPTIONS

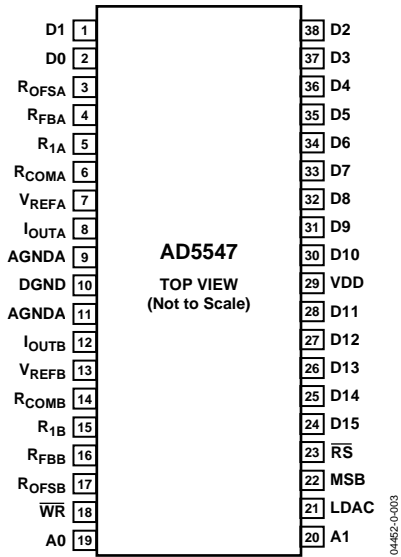

Figure 4. AD5547 TSSOP-38 Pin Configuration

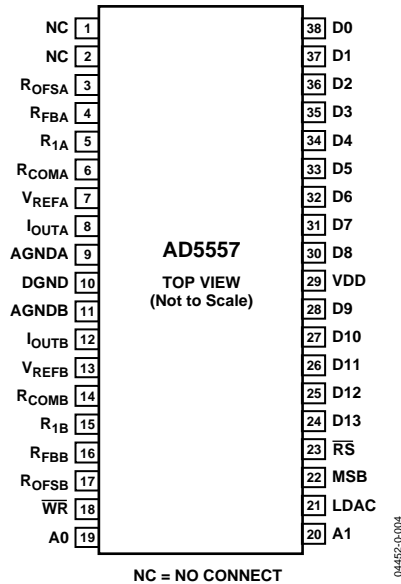

Figure 5. AD5557 TSSOP-38 Pin Configuration

Table 3. AD5547 Pin Function Descriptions

Pin No.	Mnemonic	Function
1, 2, 24–28, 30–38	D0–D15	Digital Input Data Bits D0 to D15. Signal level must be $\leq V_{DD} + 0.3 V$.
3	ROFSA	Bipolar Offset Resistor A. Accepts up to $\pm 18 V$. In 2-quadrant mode, ROFSA ties to RFBA. In 4-quadrant mode, ROFSA ties to R1A and the external reference.
4	RFBA	Internal Matching Feedback Resistor A. Connects to the external op amp for I-V conversion.
5	R1A	4-Quadrant Resistor. In 2-quadrant mode, R1A shorts to the VREFA pin. In 4-quadrant mode, R1A ties to ROFSA. Do not connect when operating in unipolar mode.
6	RCOMA	Center Tap Point of the Two 4-Quadrant Resistors, R1A and R2A. In 4-quadrant mode, RCOMA ties to the inverting node of the reference amplifier. In 2-quadrant mode, RCOMA shorts to the VREF pin. Do not connect if operating in unipolar mode.
7	VREFA	DAC A Reference Input in 2-Quadrant Mode, R2 Terminal in 4-Quadrant Mode. In 2-quadrant mode, VREFA is the reference input with constant input resistance versus code. In 4-quadrant mode, VREFA is driven by the external reference amplifier.
8	IOUTA	DAC A Current Output. Connects to the inverting terminal of external precision I-V op amp for voltage output.
9	AGNDA	DAC A Analog Ground.
10	DGND	Digital Ground.
11	AGNDB	DAC B Analog Ground.
12	IOUTB	DAC B Current Output. Connects to inverting terminal of external precision I-V op amp for voltage output.
13	VREFB	DAC B Reference Input Pin. Establishes DAC full-scale voltage. Constant input resistance versus code. If configured with an external op amp for 4-quadrant multiplying, VREFB becomes $-V_{REF}$.
14	RCOMB	Center Tap Point of the Two 4-Quadrant Resistors, R1B and R2B. In 4-quadrant mode, RCOMB ties to the inverting node of the reference amplifier. In 2-quadrant mode, RCOMB shorts to the VREF pin. Do not connect if operating in unipolar mode.
15	R1B	4-Quadrant Resistor. In 2-quadrant mode, R1B shorts to the VREFB pin. In 4-quadrant mode, R1B ties to ROFSB. Do not connect if operating in unipolar mode.
16	RFBB	Internal Matching Feedback Resistor B. Connects to external op amp for I-V conversion.
17	ROFSB	Bipolar Offset Resistor B. Accepts up to $\pm 18 V$. In 2-quadrant mode, ROFSB ties to RFBB. In 4-quadrant mode, ROFSB ties to R1B and an external reference.

Pin No.	Mnemonic	Function
18	WR	Write Control Digital Input In, Active Low. WR transfers shift register data to the DAC register on the rising edge. Signal level must be $\leq V_{DD} + 0.3$ V.
19	A0	Address Pin 0. Signal level must be $\leq V_{DD} + 0.3$ V.
20	A1	Address Pin 1. Signal level must be $\leq V_{DD} + 0.3$ V.
21	LDAC	Digital Input Load DAC Control. Signal level must be $\leq V_{DD} + 0.3$ V.
22	MSB	Power-On Reset State. MSB = 0 corresponds to zero-scale reset; MSB = 1 corresponds to midscale reset. The signal level must be $\leq V_{DD} + 0.3$ V.
23	\overline{RS}	Active low resets both input and DAC registers. Resets to zero-scale if MSB = 0, and to midscale if MSB = 1. Signal level must be $\leq V_{DD} + 0.3$ V.
29	VDD	Positive Power Supply Input. The specified range of operation is 2.7 V to 5.5 V.

Table 4. AD5557 Pin Function Descriptions



Pin No.	Mnemonic	Function
1, 2	NC	No Connection. Do not connect anything other than dummy pads to these pins.
3	R _{OFSA}	Bipolar Offset Resistor A. Accepts up to ± 18 V. In 2-quadrant mode, R _{OFSA} ties to R _{FBA} . In 4-quadrant mode, R _{OFSA} ties to R _{1A} and the external reference.
4	R _{FBA}	Internal Matching Feedback Resistor A. Connects to the external op amp for I-V conversion.
5	R _{1A}	4-Quadrant Resistor. In 2-quadrant mode, R _{1A} shorts to the V _{REFA} pin. In 4-quadrant mode, R _{1A} ties to R _{OFSA} . Do not connect when operating in unipolar mode.
6	R _{COMA}	Center Tap Point of the Two 4-Quadrant Resistors, R _{1A} and R _{2A} . In 4-quadrant mode, R _{COMA} ties to the inverting node of the reference amplifier. In 2-quadrant mode, R _{COMA} shorts to the VREF pin. Do not connect if operating in unipolar mode.
7	V _{REFA}	DAC A Reference Input in 2-Quadrant Mode, R2 Terminal in 4-Quadrant Mode. In 2-quadrant mode, V _{REFA} is the reference input with constant input resistance versus code. In 4-quadrant mode, V _{REFA} is driven by the external reference amplifier.
8	I _{OUTA}	DAC A Current Output. Connects to the inverting terminal of external precision I-V op amp for voltage output.
9	AGNDA	DAC A Analog Ground.
10	DGND	Digital Ground.
11	AGNDB	DAC B Analog Ground.
12	I _{OUTB}	DAC B Current Output. Connects to inverting terminal of external precision I-V op amp for voltage output.
13	V _{REFB}	DAC B Reference Input Pin. Establishes DAC full-scale voltage. Constant input resistance versus code. If configured with an external op amp for 4-quadrant multiplying, V _{REFB} becomes $-V_{REF}$.
14	R _{COMB}	Center Tap Point of the Two 4-Quadrant Resistors, R _{1B} and R _{2B} . In 4-quadrant mode, R _{COMB} ties to the inverting node of the reference amplifier. In 2-quadrant mode, R _{COMB} shorts to the VREF pin. Do not connect if operating in unipolar mode.
15	R _{1B}	4-Quadrant Resistor. In 2-quadrant mode, R _{1B} shorts to the V _{REFB} pin. In 4-quadrant mode, R _{1B} ties to R _{OFSB} . Do not connect if operating in unipolar mode.
16	R _{FBB}	Internal Matching Feedback Resistor B. Connects to external op amp for I-V conversion.
17	R _{OFSB}	Bipolar Offset Resistor B. Accepts up to ± 18 V. In 2-quadrant mode, R _{OFSB} ties to R _{FBB} . In 4-quadrant mode, R _{OFSB} ties to R _{1B} and an external reference.
18	WR	Write Control Digital Input In, Active Low. Transfers shift register data to the DAC register on the rising edge. Signal level must be $\leq V_{DD} + 0.3$ V.
19	A0	Address Pin 0. Signal level must be $\leq V_{DD} + 0.3$ V.
20	A1	Address Pin 1. Signal level must be $\leq V_{DD} + 0.3$ V.
21	LDAC	Digital Input Load DAC Control. Signal level must be $\leq V_{DD} + 0.3$ V.
22	MSB	Power-On Reset State. MSB = 0 corresponds to zero-scale reset; MSB = 1 corresponds to midscale reset. The signal level must be $\leq V_{DD} + 0.3$ V.
23	\overline{RS}	Active low resets both input and DAC registers. Resets to zero-scale if MSB = 0, and to midscale if MSB = 1. Signal level must be $\leq V_{DD} + 0.3$ V.
24–28, 30–38	D13 to D0	Digital Input Data Bits D13 to D0. Signal level must be $\leq V_{DD} + 0.3$ V.
29	VDD	Positive Power Supply Input. The specified range of operation is 2.7 V to 5.5 V.

AD5547/AD5557

Table 5. Address Decoder Pins

A1	A0	Output Update
0	0	DAC A
0	1	None
1	0	DAC A and B
1	1	DAC B

Table 6. Control Inputs

RS	WR	LDAC	Register Operation
0	X	X	Reset the output to 0 with MSB pin = 0; reset the output to midscale with MSB pin = 1.
1	0	0	Load the input register with data bits.
1	1	1	Load the DAC register with the contents of the input register.
1	0	1	The input and DAC registers are transparent.
1			When LDAC and \overline{WR} are tied together and programmed as a pulse, the data bits are loaded into the input register on the falling edge of the pulse, and are then loaded into the DAC register on the rising edge of the pulse.
1	1	0	No register operation.

TYPICAL PERFORMANCE CHARACTERISTICS

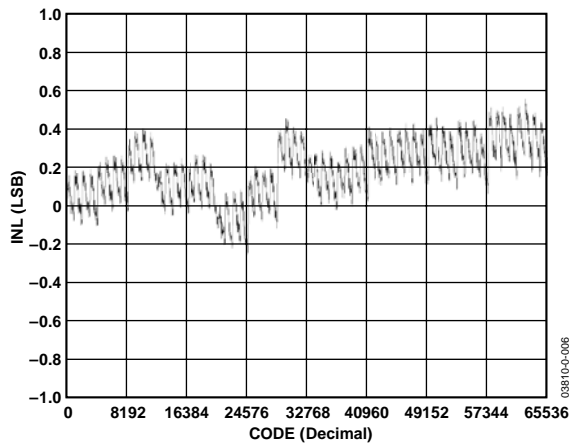

Figure 6. AD5547 Integral Nonlinearity Error

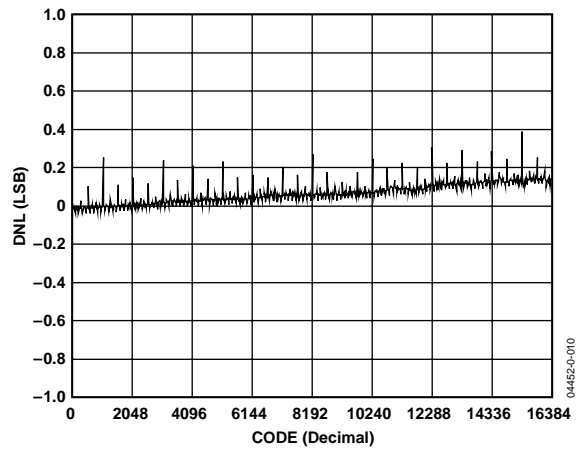

Figure 9. AD5557 Differential Nonlinearity Error

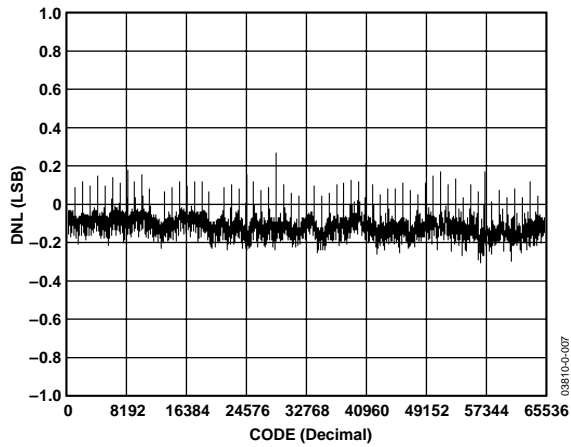

Figure 7. AD5547 Differential Nonlinearity Error

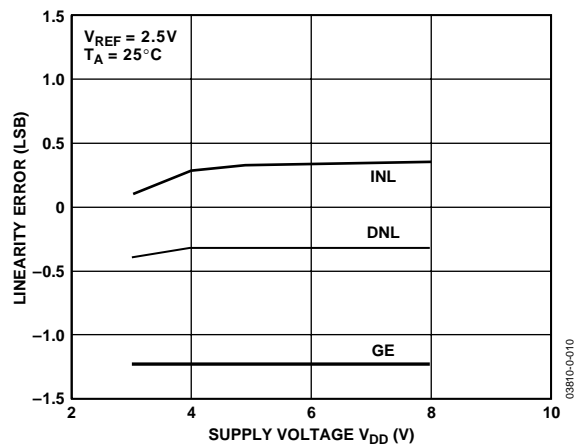

Figure 10. Linearity Error vs. V_{DD}

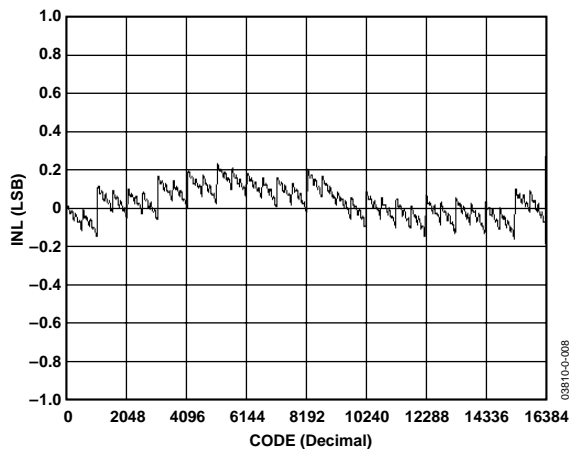

Figure 8. AD5557 Integral Nonlinearity Error

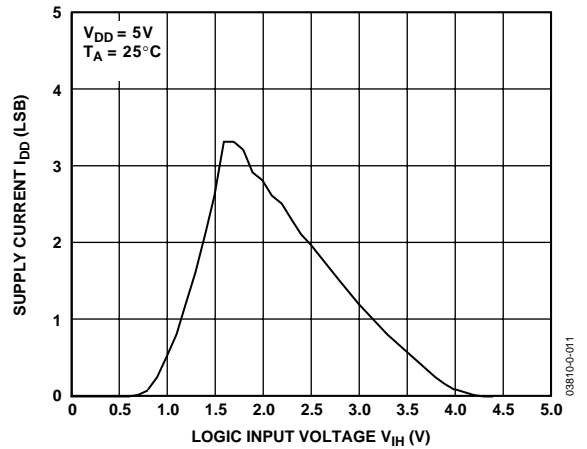

Figure 11. Supply Current vs. Logic Input Voltage

AD5547/AD5557

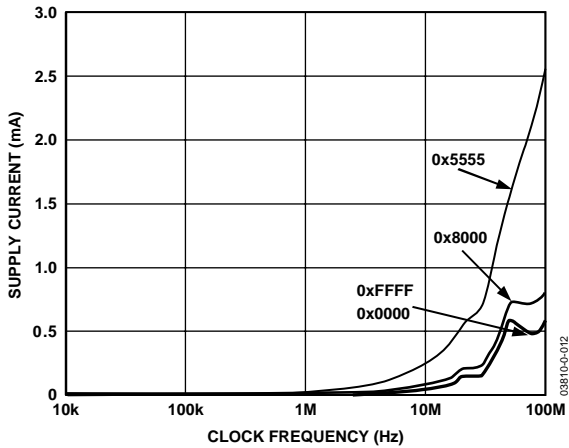

Figure 12. AD5547 Supply Current vs. Clock Frequency

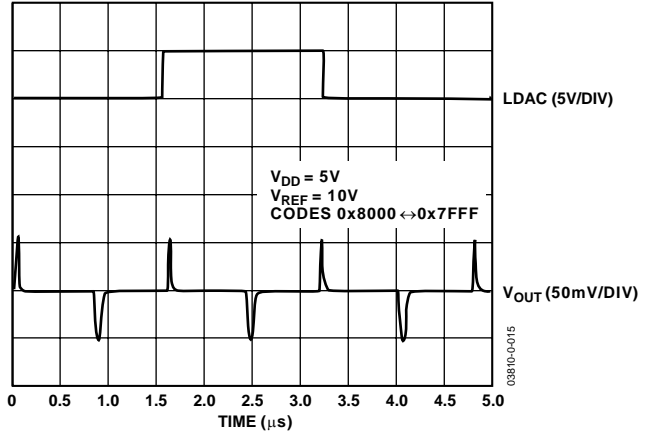

Figure 15. AD5547 Midscale Transition and Digital Feedthrough

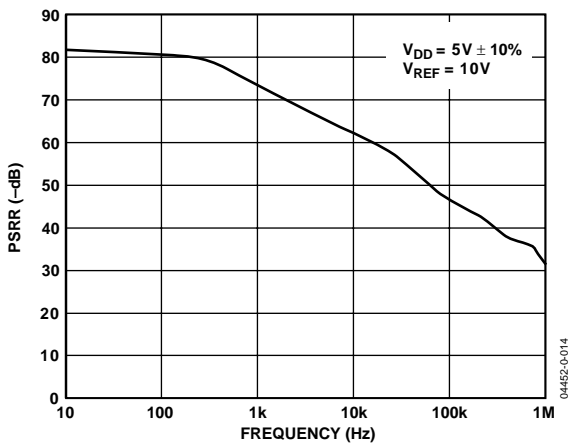

Figure 13. Power Supply Rejection Ratio vs. Frequency

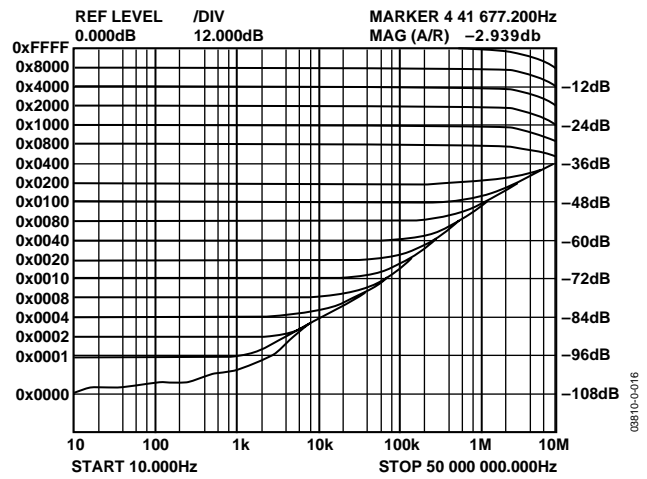

Figure 16. AD5547 Unipolar Reference Multiplying Bandwidth

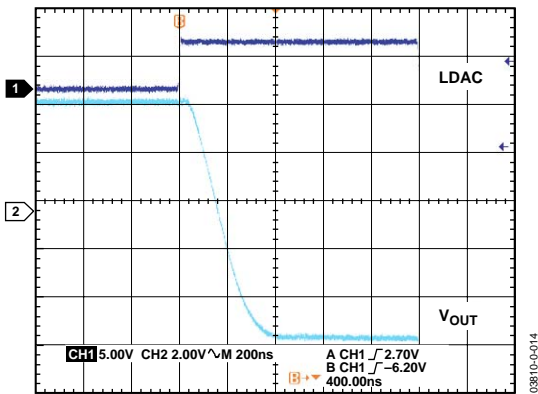

Figure 14. Settling Time from Full Scale to Zero Scale

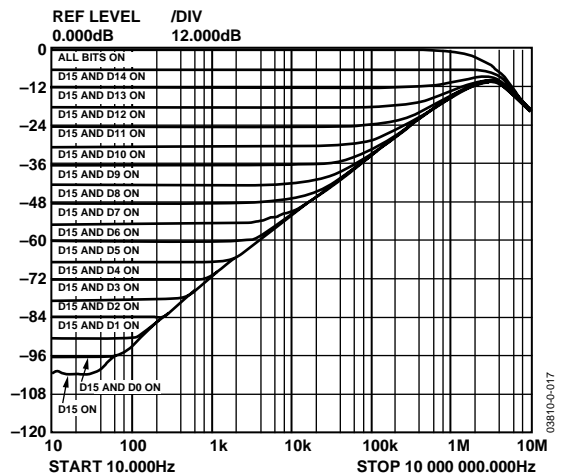

Figure 17. AD5547 Bipolar Reference Multiplying Bandwidth (Codes from Midscale to Full Scale)

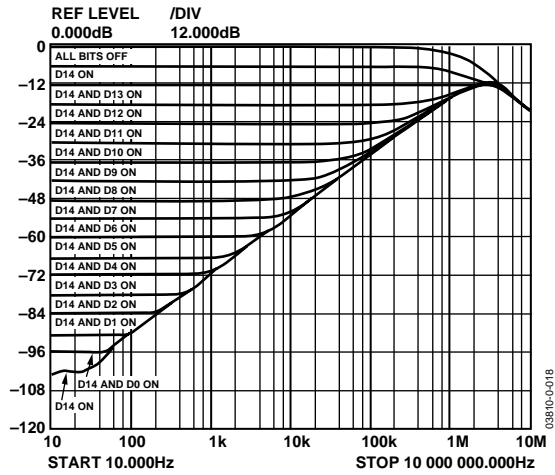

Figure 18. AD5547 Bipolar Reference Multiplying Bandwidth (Codes from Midscale to Zero Scale)

CIRCUIT OPERATION

D/A CONVERTER SECTION

The AD5547/AD5557 are 16-/14-bit, multiplying, current output, parallel input DACs. The devices operate from a single 2.7 V to 5.5 V supply, and provide both unipolar (0 V to $-V_{REF}$ or 0 V to $+V_{REF}$), and bipolar ($\pm V_{REF}$) output ranges from -18 V to $+18$ V references. In addition to the precision conversion R_{FB} commonly found in current output DACs, there are three additional precision resistors for 4-quadrant bipolar applications.

The AD5547/AD5557 consist of two groups of precision R-2R ladders, which make up the 12/10 LSBs, respectively. Furthermore, the 4 MSBs are decoded into 15 segments of resistor value 2R. Figure 19 shows the architecture of the 16-bit AD5547. Each of the 16 segments and the R-2R ladder carries an equally weighted current of one-sixteenth of full scale. The feedback resistor R_{FB} and 4-quadrant resistor R_{OFS} have values of 10 k Ω . Each 4-quadrant resistor, R1 and R2, equals 5 k Ω . In 4-quadrant operation, R1, R2, and an external op amp work together to invert the reference voltage and apply it to the VREF input. With R_{OFS} and R_{FB} connected as shown in Figure 2, the output can swing from $-V_{REF}$ to $+V_{REF}$.

The reference voltage inputs exhibit a constant input resistance of 5 k Ω \pm 20%. The impedance of I_{OUT} , the DAC output, is code dependent. External amplifier choice should take into account

the variation of the AD5547/AD5557 output impedance. The feedback resistance in parallel with the DAC ladder resistance dominates output voltage noise. To maintain good analog performance, it is recommended that the power supply is bypassed with a 0.01 μ F to 0.1 μ F ceramic or chip capacitor in parallel with a 1 μ F tantalum capacitor. Also, to minimize gain error, PCB metal traces between V_{REF} and R_{FB} should match.

Every code change of the DAC corresponds to a step function; gain peaking at each output step may occur if the op amp has limited GBP and excessive parasitic capacitance present at the op amp's inverting node. A compensation capacitor, therefore, may be needed between the I-V op amp inverting and output nodes to smooth the step transition. Such a compensation capacitor should be found empirically, but a 20 pF capacitor is generally adequate for the compensation.

The V_{DD} power is used primarily by the internal logic to drive the DAC switches. Note that the output precision degrades if the operating voltage falls below the specified voltage. Users should also avoid using switching regulators because device power supply rejection degrades at higher frequencies.

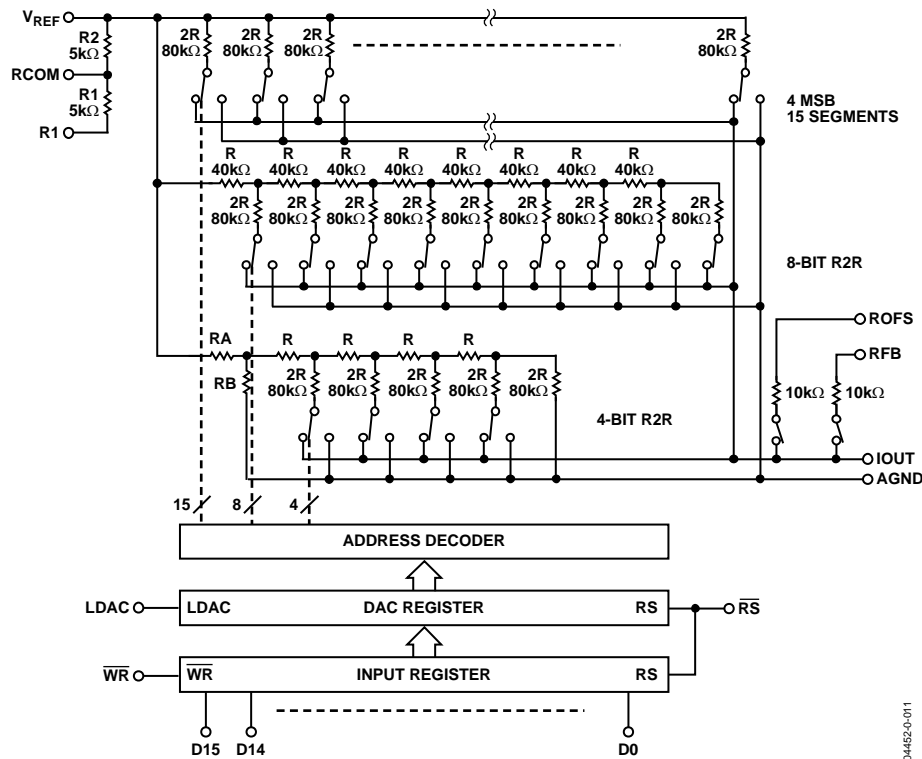

Figure 19. 16-Bit AD5547 Equivalent R-2R DAC Circuit with Digital Section, One Channel Shown

DIGITAL SECTION

The AD5547/AD5557 have 16-/14-bit parallel inputs. The devices are double-buffered with 16-/14-bit registers. The double-buffered feature allows the simultaneous update of several AD5547/AD5557s. For the AD5547, the input register is loaded directly from a 16-bit controller bus when \overline{WR} is brought low. The DAC register is updated with data from the input register when LDAC is brought high. Updating the DAC register updates the DAC output with the new data (see Figure 19). To make both registers transparent, tie \overline{WR} low and LDAC high. The asynchronous \overline{RS} pin resets the part to zero scale if the MSB pin = 0, and to midscale if the MSB pin = 1.

ESD Protection Circuits

All logic input pins contain back-biased ESD protection Zeners connected to ground (GND) and V_{DD} , as shown in Figure 20. As a result, the voltage level of the logic input should not be greater than the supply voltage.

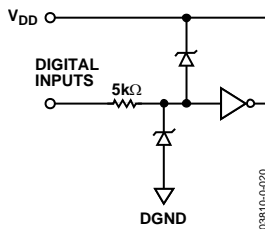

Figure 20. Equivalent ESD Protection Circuits

Amplifier Selection

In addition to offset voltage, the bias current is important in op amp selection for precision current output DACs. A 30 nA input bias current in the op amp contributes to 1 LSB in the AD5547's full-scale error. The OP1177 and AD8628 op amps are good candidates for the I-V conversion.

Reference Selection

The initial accuracy and rated output of the voltage reference determine the full-span adjustment. The initial accuracy of the reference is usually a secondary concern because it can be trimmed. Figure 26 shows an example of a trimming circuit. The zero-scale error can also be minimized by standard op amp nulling techniques.

The voltage reference temperature coefficient and long-term drift are primary considerations. For example, a 5 V reference with a TC of 5 ppm/°C means the output changes by 25 $\mu\text{V}/^\circ\text{C}$. As a result, a reference operating at 55°C contributes an additional 750 μV full-scale error.

Similarly, the same 5 V reference with a ± 50 ppm long-term drift means the output may change by ± 250 μV over time. Therefore, it is practical to calibrate a system periodically to maintain its optimum precision.

PCB LAYOUT, POWER SUPPLY BYPASSING, AND GROUND CONNECTIONS

It is a good practice to employ a compact, minimum-lead length PCB layout design. The leads to the input should be as short as possible to minimize IR drop and stray inductance.

The PCB metal traces between V_{REF} and R_{FB} should also be matched to minimize gain error.

It is also essential to bypass the power supply with quality capacitors for optimum stability. Supply leads to the device should be bypassed with 0.01 μF to 0.1 μF disc or chip ceramic capacitors. Low ESR 1 μF to 10 μF tantalum or electrolytic capacitors should also be applied at the supply in parallel with the ceramic capacitor to minimize transient disturbance and filter out low frequency ripple.

To minimize the digital ground bounce, the AD5547/AD5557 DGND terminal should be joined with the AGND terminal at a single point. Figure 21 illustrates the basic supply-bypassing configuration and AGND/DGND connection for the AD5547/AD5557.

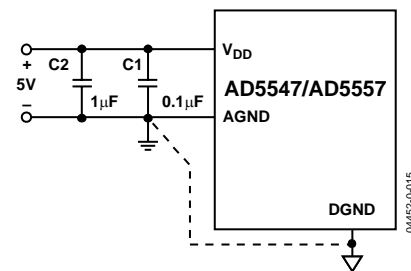

Figure 21. Power Supply Bypassing

2-Quadrant Multiplying Mode, $V_{OUT} = 0\text{ V to }+V_{REF}$

The AD5547/AD5557 are designed to operate with either positive or negative reference voltages. As a result, a positive output can be achieved with an additional op amp, (see Figure 23); the output becomes

$$V_{OUT} = +V_{REF} \times D/65,536 \text{ (AD5547)} \quad (3)$$

$$V_{OUT} = +V_{REF} \times D/16,384 \text{ (AD5557)} \quad (4)$$

Table 8 shows the positive output versus code for the AD5547.

Table 8. AD5547 Unipolar Mode Positive Output vs. Code

D in Binary	V_{OUT} (V)
1111 1111 1111 1111	$+V_{REF}(65,535/65,536)$
1000 0000 0000 0000	$+V_{REF}/2$
0000 0000 0000 0001	$+V_{REF}(1/65,536)$
0000 0000 0000 0000	0

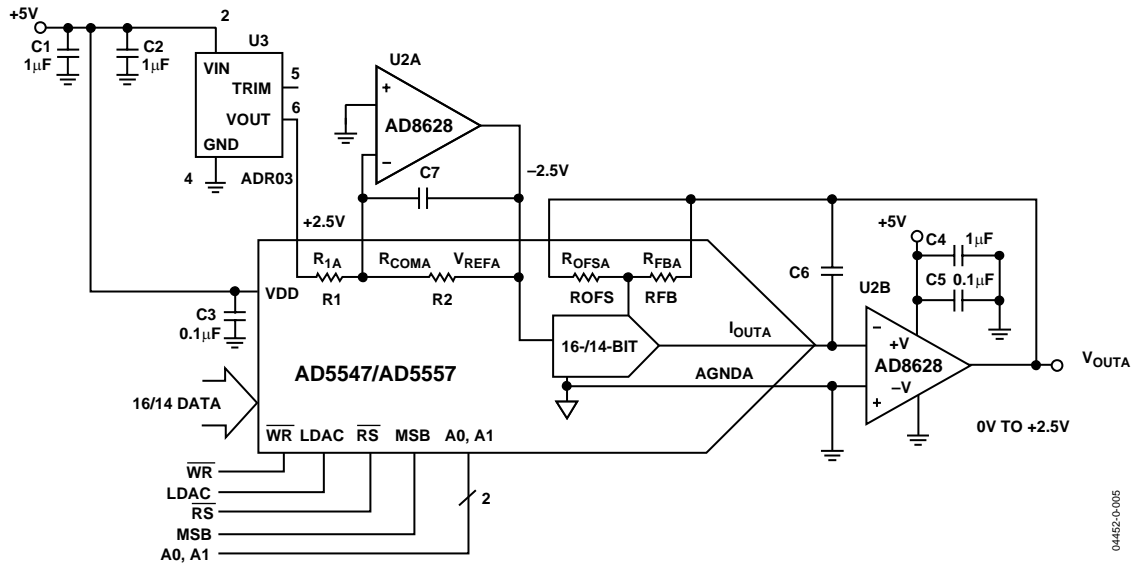

Figure 23. Unipolar 2-Quadrant Multiplying Mode, $V_{OUT} = 0\text{ to }+V_{REF}$

AD5547/AD5557

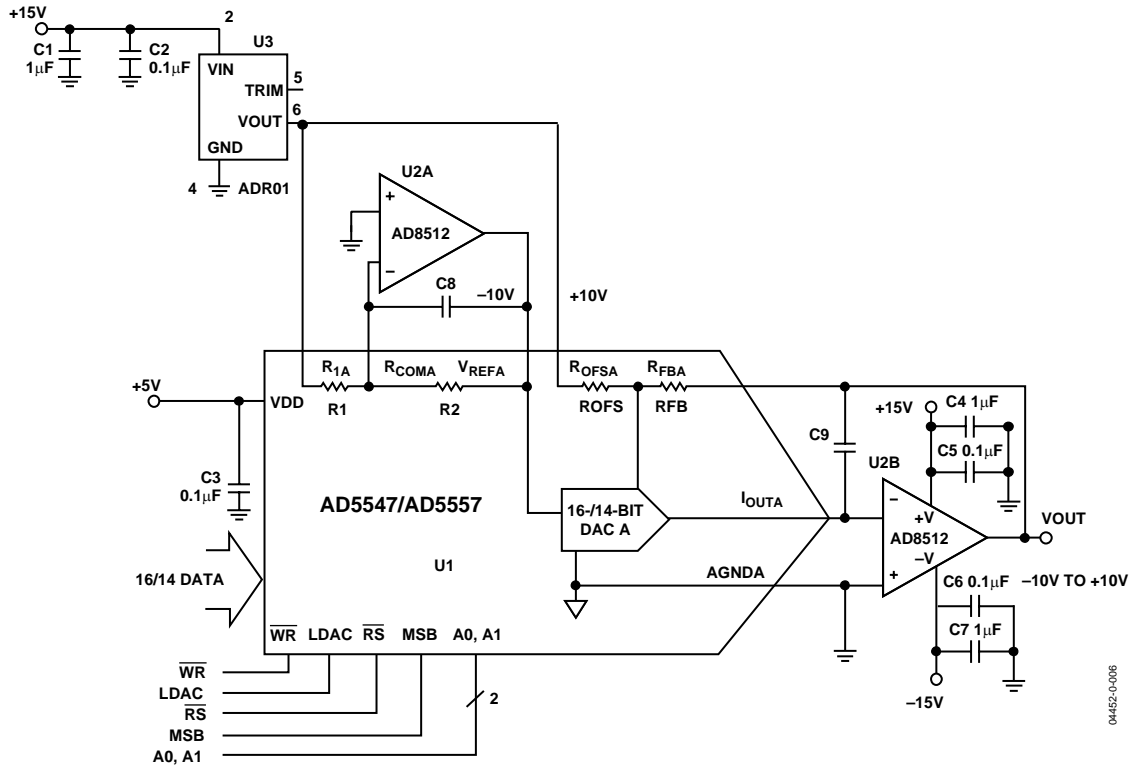

Figure 24. 4-Quadrant Multiplying Mode, $V_{OUT} = -V_{REF}$ to $+V_{REF}$

BIPOLAR MODE

4-Quadrant Multiplying Mode, $V_{OUT} = -V_{REF}$ to $+V_{REF}$

The AD5547/AD5557 contain on-chip all the 4-quadrant resistors necessary for precision bipolar multiplying operation. Such a feature minimizes the number of exponent components to only a voltage reference, dual op amp, and compensation capacitor (see Figure 24). For example, with a +10 V reference, the circuit yields a precision, bipolar -10 V to +10 V output. Table 9 shows some of the results for the 16-bit AD5547.

$$V_{OUT} = (D/32768 - 1) \times V_{REF} \text{ (AD5547)} \quad (5)$$

$$V_{OUT} = (D/16384 - 1) \times V_{REF} \text{ (AD5557)} \quad (6)$$

Table 9. AD5547 Output vs. Code

D in Binary	V _{OUT}
1111 1111 1111 1111	+V _{REF} (32,767/32,768)
1000 0000 0000 0001	+V _{REF} (1/32,768)
1000 0000 0000 0000	0
0111 1111 1111 1111	-V _{REF} (1/32,768)
0000 0000 0000 0000	-V _{REF}

AC Reference Signal Attenuator

Besides handling the digital waveform decoded from the parallel input data, the AD5547/AD5557 can also handle low frequency ac reference signals for signal attenuation, channel equalization, and waveform generation applications. The maximum signal range can be up to ± 18 V (See Figure 25).

System Calibration

The initial accuracy of the system can be adjusted by trimming the voltage reference ADR0x with a digital potentiometer (see Figure 26). The AD5170 provides a one-time programmable (OTP), 8-bit adjustment that is ideal and reliable for such calibration. ADI's OTP digital potentiometer comes with programmable software that simplifies factory calibration.

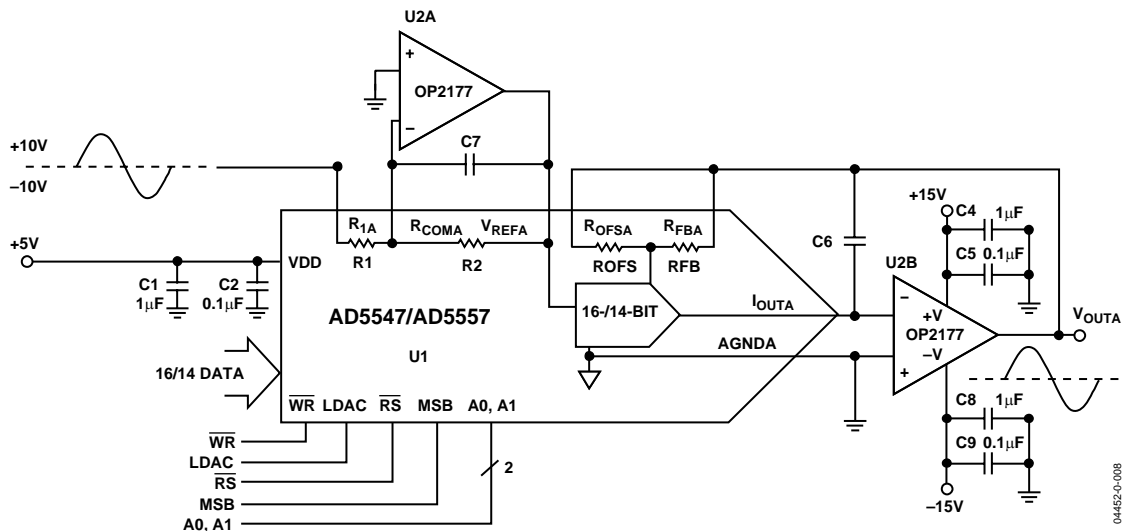

Figure 25. Signal Attenuator with AC Reference

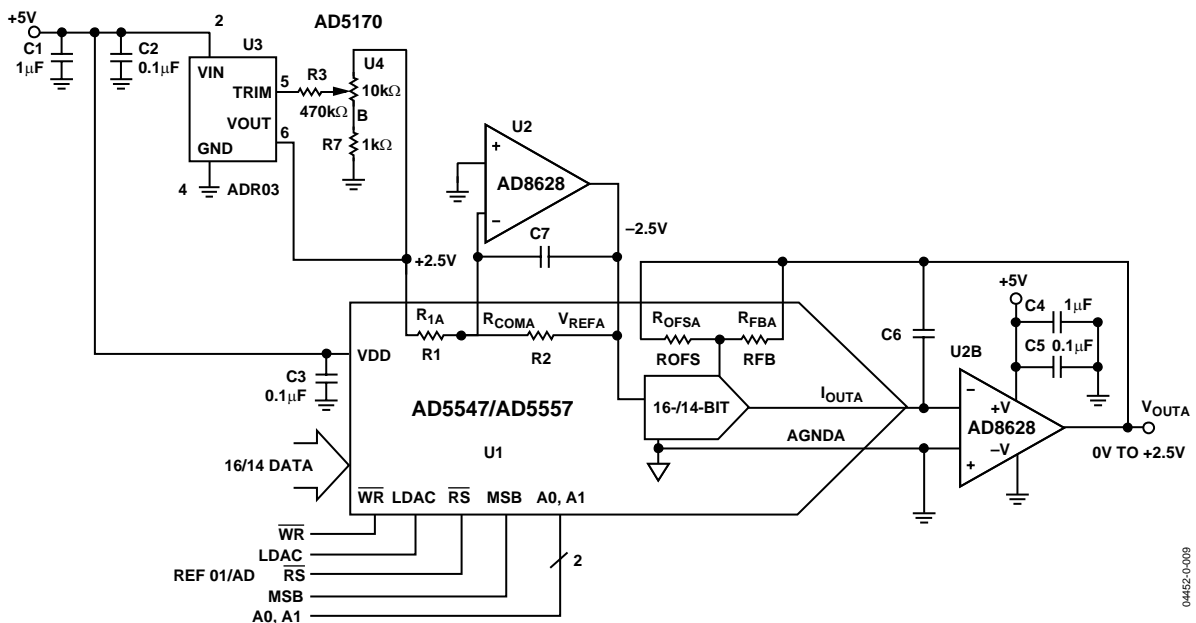

Figure 26. Full-Span Calibration

AD5547/AD5557

Table 10 lists the latest DACs available from Analog Devices.

Table 10. ADI Current Output DACs

Model	Bits	Outputs	Interface	Package	Comments
AD5425	8	1	SPI, 8-Bit Load	MSOP-10	Fast 8-bit load; see also AD5426.
AD5426	8	1	SPI	MSOP-10	See also AD5425 fast load.
AD5450	8	1	SPI	SOT23-8	See also AD5425 fast load.
AD5424	8	1	Parallel	TSSOP-16	
AD5429	8	2	SPI	TSSOP-16	
AD5428	8	2	Parallel	TSSOP-20	
AD5432	10	1	SPI	MSOP-10	
AD5451	10	1	SPI	SOT23-8	
AD5433	10	1	Parallel	TSSOP-20	
AD5439	10	2	SPI	TSSOP-16	
AD5440	10	2	Parallel	TSSOP-24	
AD5443	12	1	SPI	MSOP-10	See also AD5452 and AD5444.
AD5452	12	1	SPI	SOT23-8	Higher accuracy version of AD5443; see also AD5444.
AD5445	12	1	Parallel	TSSOP-20	
AD5444	12	1	SPI	MSOP-10	Higher accuracy version of AD5443; see also AD5452.
AD5449	12	2	SPI	TSSOP-16	
AD5415	12	2	SPI	TSSOP-24	Uncommitted resistors.
AD5447	12	2	Parallel	TSSOP-24	
AD5405	12	2	Parallel	LFCSP-40	Uncommitted resistors.
AD5453	14	1	SPI	SOT23-8	
AD5553	14	1	SPI	MSOP-8	
AD5556	14	1	Parallel	TSSOP-28	
AD5446	14	1	SPI	MSOP-10	MSOP version of AD5453; compatible with AD5443, AD5432, and AD5426.
AD5555	14	2	SPI	TSSOP-16	
AD5557	14	2	Parallel	TSSOP-38	
AD5543	16	1	SPI	MSOP-8	
AD5546	16	1	Parallel	TSSOP-28	
AD5545	16	2	SPI	TSSOP-16	
AD5547	16	2	Parallel	TSSOP-38	

OUTLINE DIMENSIONS

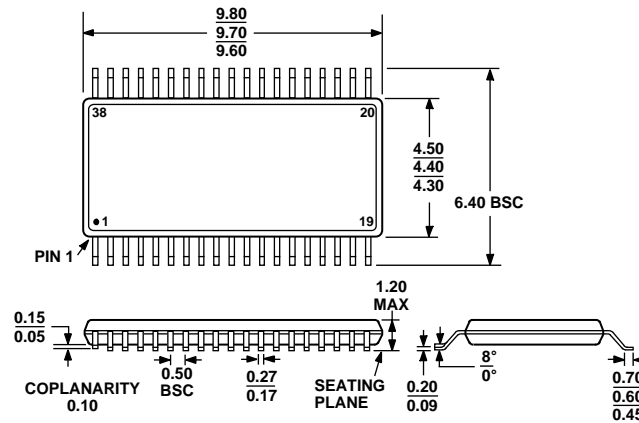

COMPLIANT TO JEDEC STANDARDS MO-153BD-1

Figure 27. 38-Lead Thin Shrink Small Outline Package [TSSOP]
(RU-38)

Dimensions shown in millimeters

ORDERING GUIDE

Model	Resolution (Bits)	DNL (LSB)	INL (LSB)	Temperature Range	Ordering Quantity	Package Description	Package Option
AD5547BRU	16	±1	±2	-40°C to +125°C	50	Thin Shrink Small Outline Package (TSSOP)	RU-38
AD5547BRU-REEL7	16	±1	±2	-40°C to +125°C	1,000	Thin Shrink Small Outline Package (TSSOP)	RU-38
AD5557CRU	14	±1	±1	-40°C to +125°C	50	Thin Shrink Small Outline Package (TSSOP)	RU-38
AD5557CRU-REEL7	14	±1	±1	-40°C to +125°C	1,000	Thin Shrink Small Outline Package (TSSOP)	RU-38

AD5547/AD5557

NOTES