

ADC0803, ADC0805 8-BIT ANALOG-TO-DIGITAL CONVERTERS WITH DIFFERENTIAL INPUTS

SLAS034 – NOVEMBER 1983 – REVISED SEPTEMBER 1986

- **8-Bit Resolution**
- **Ratiometric Conversion**
- **100- μ s Conversion Time**
- **135-ns Access Time**
- **Guaranteed Monotonicity**
- **High Reference Ladder Impedance
8 k Ω Typical**
- **No Zero Adjust Requirement**
- **On-Chip Clock Generator**
- **Single 5-V Power Supply**
- **Operates With Microprocessor or as
Stand-Alone**
- **Designed to Be interchangeable With
National Semiconductor and Signetics
ADC0803 and ADC0805**

**N PACKAGE
(TOP VIEW)**

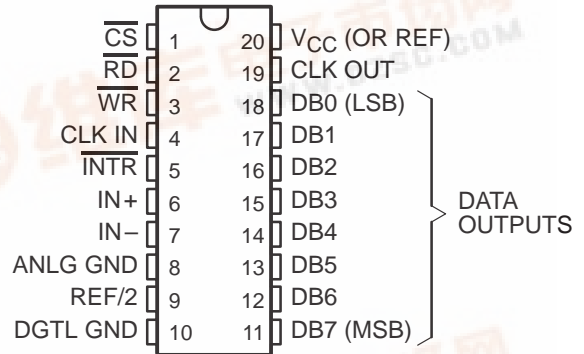

description

The ADC0803 and ADC0805 are CMOS 8-bit, successive-approximation, analog-to-digital converters that use a modified potentiometric (256R) ladder. These devices are designed to operate from common microprocessor control buses with the 3-state output latches driving the data bus. The devices can be made to appear to the microprocessor as a memory location or an I/O port. Detailed information on interfacing to most popular microprocessors is readily available from the factory.

A differential analog voltage input allows increased common-mode rejection and offset of the zero-input analog voltage value. Although a reference input (REF/2) is available to allow 8-bit conversion over smaller analog voltage spans or to make use of an external reference, ratiometric conversion is possible with the REF/2 input open. Without an external reference, the conversion takes place over a span from V_{CC} to ANLG GND. The devices can operate with an external clock signal or with an additional resistor and capacitor, using an on-chip clock generator.

The ADC0803C and ADC0805C are characterized for operation from 0°C to 70°C. The ADC0803I and ADC0805I are characterized for operation from -40°C to 85°C.



ADC0803, ADC0805

8-BIT ANALOG-TO-DIGITAL CONVERTERS

WITH DIFFERENTIAL INPUTS

SLAS034 – NOVEMBER 1983 – REVISED SEPTEMBER 1986

functional block diagram (positive logic)

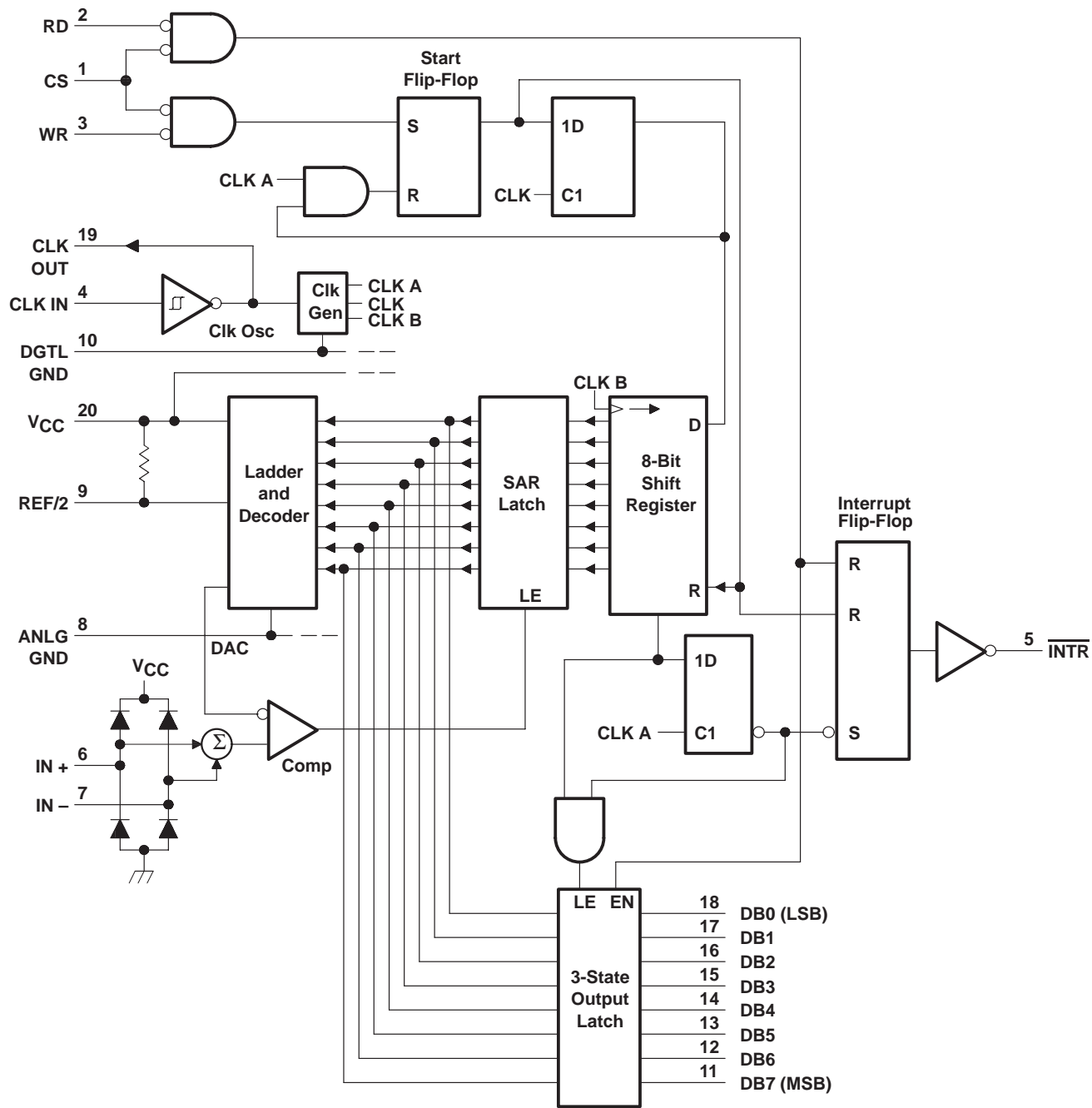

ADC0803, ADC0805 8-BIT ANALOG-TO-DIGITAL CONVERTERS WITH DIFFERENTIAL INPUTS

SLAS034 – NOVEMBER 1983 – REVISED SEPTEMBER 1986

absolute maximum ratings over operating free-air temperature range (unless otherwise noted)

Supply voltage, V_{CC} (see Note 1)	6.5 V
Input voltage range: \overline{CS} , \overline{RD} , \overline{WR}	–0.3 V to 18 V
Other inputs	–0.3 V to V_{CC} 0.3 V
Output voltage range	–0.3 V to V_{CC} 0.3 V
Operating free-air temperature range: ADC080_C	0°C to 70°C
ADC080_I	–40°C to 85°C
Storage temperature range	– 65°C to 150°C
Lead temperature 1,6 mm (1/16 inch) from case for 10 seconds	260°C

NOTE 1: All voltage values are with respect to digital ground (DGTL GND) with DGTL GND and ANLG GND connected together unless otherwise noted.

recommended operating conditions

	MIN	NOM	MAX	UNIT
Supply voltage, V_{CC}	4.5	5	6.3	V
Analog input voltage (see Note 2)	–0.05	$V_{CC} = 0.05$		V
Voltage at REF/2 (see Note 3), $V_{REF/2}$	0.25	2.5		V
High-level input voltage at \overline{CS} , \overline{RD} , or \overline{WR} , V_{IH}	2		15	V
Low-level input voltage at \overline{CS} , \overline{RD} , or \overline{WR} , V_{IL}			0.8	V
Analog ground voltage (see Note 4)	–0.05	0	1	V
Clock input frequency (see Note 5), f_{clock}	100	640	1460	kHz
Duty cycle for f_{clock} above 640 kHz (see Note 5)	40%		60%	
Pulse duration, clock input (high or low) for f_{clock} below 640 kHz, $t_W(\text{CLK})$	275	781		ns
Pulse duration, \overline{WR} input low, $t_W(\overline{WR})$	100			ns
Operating free-air temperature, T_A	ADC080_C		0	°C
	ADC080_I		–40	

- NOTES:
2. When the differential input voltage ($V_{I+} - V_{I-}$) is less than or equal to 0 V, the output code is 0000 0000.
 3. The internal reference voltage is equal to the voltage applied to REF/2 or approximately equal to one-half of the V_{CC} when REF/2 is left open. The voltage at REF/2 should be one-half the full-scale differential input voltage between the analog inputs. Thus, the differential input voltage range when REF/2 is open and $V_{CC} = 5$ V is 0 V to 5 V. $V_{REF/2}$ for an input voltage range from 0.5 V to 3.5 V (full-scale differential voltage of 3 V) is 1.5 V.
 4. These values are with respect to DGTL GND.
 5. Total unadjusted error is specified only at an f_{clock} of 640 kHz with a duty cycle of 40% to 60% (pulse duration 625 ns to 937 ns). For frequencies above this limit or pulse duration below 625 ns, error may increase. The duty cycle limits should be observed for an f_{clock} greater than 640 kHz. Below 640 kHz, this duty cycle limit can be exceeded provided $t_W(\text{CLK})$ remains within limits.

ADC0803, ADC0805

8-BIT ANALOG-TO-DIGITAL CONVERTERS

WITH DIFFERENTIAL INPUTS

SLAS034 – NOVEMBER 1983 – REVISED SEPTEMBER 1986

electrical characteristics over recommended range of operating free-air temperature, $V_{CC} = 5\text{ V}$, $f_{\text{clock}} = 640\text{ kHz}$, $V_{\text{REF}/2} = 2.5\text{ V}$ (unless otherwise noted)

PARAMETER		TEST CONDITIONS		MIN	TYP†	MAX	UNIT
VOH	High-level output voltage	All outputs	$V_{CC} = 4.75\text{ V}$, $I_{OH} = -360\text{ }\mu\text{A}$	2.4			V
		DB and INTR	$V_{CC} = 4.75\text{ V}$, $I_{OH} = -10\text{ }\mu\text{A}$	4.5			
VOL	Low-level output voltage	Data outputs	$V_{CC} = 4.75\text{ V}$, $I_{OL} = 1.6\text{ mA}$			0.4	V
		INTR output	$V_{CC} = 4.75\text{ V}$, $I_{OL} = 1\text{ mA}$			0.4	
		CLK OUT	$V_{CC} = 4.75\text{ V}$, $I_{OL} = 360\text{ }\mu\text{A}$			0.4	
VT+	Clock positive-going threshold voltage			2.7	3.1	3.5	V
VT-	Clock negative-going threshold voltage			1.5	1.8	2.1	V
VT+ - VT-		Clock input hysteresis		0.6	1.3	2	V
I _{IH}	High-level input current				0.005	1	μA
I _{IL}	Low-level input current				-0.005	-1	μA
I _{OZ}	Off-state output current		$V_O = 0$			-3	μA
			$V_O = 5\text{ V}$			3	
I _{OHS}	Short-current output current	Output high	$V_O = 0$, $T_A = 25^\circ\text{C}$	-4.5	-6		mA
I _{OLS}	Short-circuit output current	Output low	$V_O = 5\text{ V}$, $T_A = 25^\circ\text{C}$	9	16		mA
I _{CC}	Supply current plus reference current		$V_{\text{REF}/2} = \text{open}$, $T_A = 25^\circ\text{C}$, $\text{CS} = 5\text{ V}$		1.1	1.8	mA
R _{REF/2}	Input resistance to reference ladder		See Note 6	2.5	8		k Ω
C _i	Input capacitance (control)				5	7.5	pF
C _o	Output capacitance (DB)				5	7.5	pF

NOTE 6: Resistance is calculated from the current drawn from a 5-V supply applied to ANLG GND and REF/2.

operating characteristics over recommended operating free-air temperature, $V_{CC} = 5\text{ V}$, $V_{\text{REF}/2} = 2.5\text{ V}$, $f_{\text{clock}} = 640\text{ kHz}$ (unless otherwise noted)

PARAMETER		TEST CONDITIONS		MIN	TYP†	MAX	UNIT
Supply-voltage-variation error		$V_{CC} = 4.5\text{ to }5.5\text{ V}$,	See Note 7		+1/16	$\pm 1/8$	LSB
Total adjusted error	ADC0803	With full-scale adjust,	See Notes 7 and 8			$\pm 1/4$	LSB
						$\pm 1/2$	
Total unadjusted error	ADC0805	$V_{\text{REF}/2} = 2.5\text{ V}$,	See Notes 7 and 8			$\pm 1/2$	LSB
				$V_{\text{REF}/2}$ open,	See Notes 7 and 8	± 1	
DC common-mode error		See Notes 7 and 8			$\pm 1/16$	$\pm 1/8$	LSB
t _{en}	Output enable time		$T_A = 25^\circ\text{C}$, $C_L = 100\text{ pF}$		135	200	ns
t _{dis}	Output disable time		$T_A = 25^\circ\text{C}$, $C_L = 10\text{ pF}$, $R_L = 10\text{ k}\Omega$		125	200	ns
t _{d(INTR)}	Delay time to reset INTR		$T_A = 25^\circ\text{C}$		300	450	nx
t _{conv}	Conversion cycle time		$f_{\text{clock}} = 100\text{ kHz to }1.46\text{ MHz}$, $T_A = 25^\circ\text{C}$, See Note 9			73	clock cycles
CR	Free-running conversion rate		INTR connected to WR, CS at 0 V	66		8770	conv/s

† All typical values are at $T_A = 25^\circ\text{C}$.

- NOTES: 7. These parameters are specified over the recommended analog input voltage range.
 8. All errors are measured with reference to an ideal straight line through the end-points of the analog-to-digital transfer characteristics.
 9. Although internal conversion is completed in 64 clock periods, a $\overline{\text{CS}}$ or WR low-to-high transition is followed by 1 to 8 clock periods before conversion starts. After conversion is complete, part of another clock period is required before a high-to-low transition of INTR completes the cycle.

ADC0803, ADC0805
8-BIT ANALOG-TO-DIGITAL CONVERTERS
WITH DIFFERENTIAL INPUTS

SLAS034 – NOVEMBER 1983 – REVISED SEPTEMBER 1986

PARAMETER MEASUREMENT INFORMATION

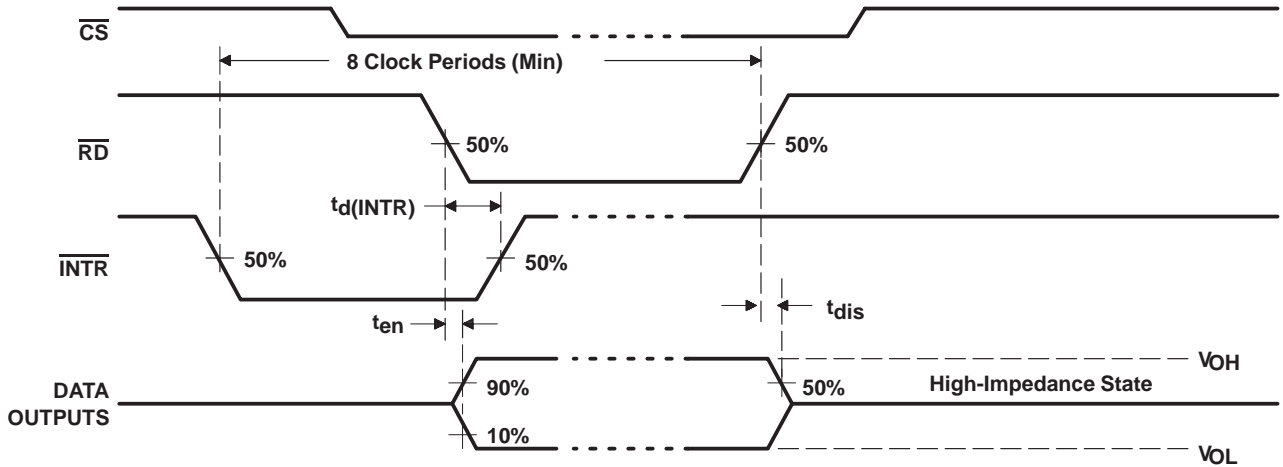

Figure 1. Read Operation Timing Diagram

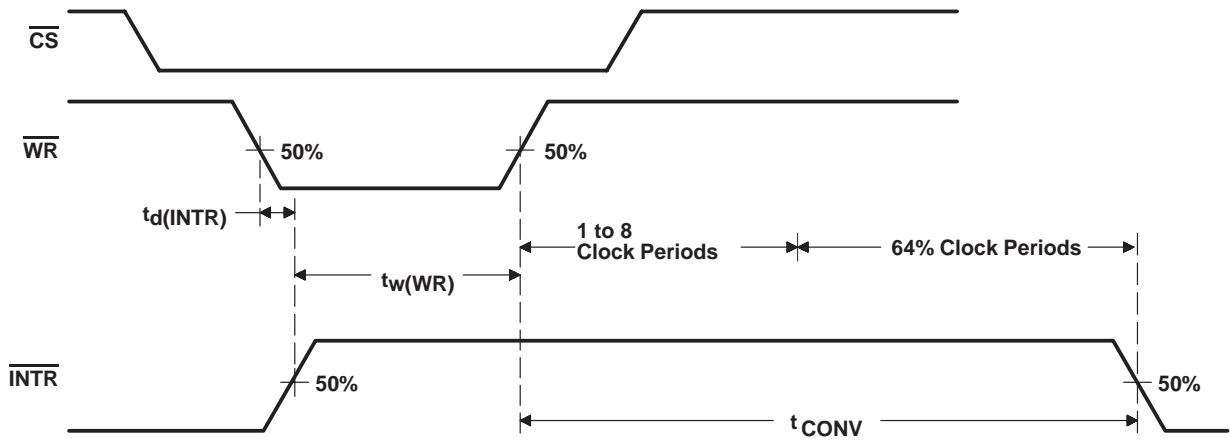

Figure 2. Write Operation Timing Diagram

ADC0803, ADC0805

8-BIT ANALOG-TO-DIGITAL CONVERTERS

WITH DIFFERENTIAL INPUTS

SLAS034 – NOVEMBER 1983 – REVISED SEPTEMBER 1986

PRINCIPLES OF OPERATION

The ADC0803 and ADC0805 each contain a circuit equivalent to 256-resistor network. Analog switches are sequenced by successive-approximation logic to match an analog differential input voltage ($V_{I+} - V_{I-}$) to a corresponding tap on the 256R network. The most significant bit (MSB) is tested first. After eight spelled out comparisons (64 clock periods), an eight-bit binary code (1111 1111 = full scale) is transferred to an output latch and the interrupt (\overline{INTR}) output goes low. The device can be operated in a free-running mode by connecting the \overline{INTR} output to the write (\overline{WR}) input and holding the conversion start (\overline{CS}) input at a low level. To ensure start up under all conditions, a low-level \overline{WR} input is required during the power-up cycle. Taking \overline{CS} low any time after that will interrupt a conversion in process.

When \overline{WR} goes low, the internal successive-approximation register (SAR) and 8-bit shift register are reset. As long as both \overline{CS} and \overline{WR} remain low, the analog-to-digital converter remains in a reset state. One to eight clock periods after \overline{CS} or \overline{WR} makes a low-to-high transition, conversion starts.

When \overline{CS} and \overline{WR} are low, the start flip-flop is set and the interrupt flip-flop and 8-bit register are reset. The next clock pulse transfers a logic high to the output of the start flip-flop. The logic high is ANDed with the next clock pulse, placing a logic high on the reset input of the start flip-flop. If either \overline{CS} or \overline{WR} have gone high, the set signal to the start flip-flop is removed, causing it to be reset. A logic high is placed on the D input of the eight-bit shift register and the conversion process is started. If \overline{CS} and \overline{WR} are still low, the start flip-flop, the 8-bit shift register, and the SAR remain reset. This action allows for wide \overline{CS} and \overline{WR} inputs, with conversion starting from one to eight clock periods after one of the inputs goes high.

When the logic high input has been clocked through the 8-bit shift register, which completes the SAR search, it is applied to an AND gate controlling the output latches and to the D input of a flip-flop. On the next clock pulse, the digital word is transferred to the 3-state output latches and the interrupt flip-flop is set. The output of the interrupt flip-flop is inverted to provide an \overline{INTR} output that is high during conversion and low when the conversion is complete.

When a low is at both \overline{CS} and \overline{RD} , an output is applied to the DB0 through DB7 outputs and the interrupt flip-flop is reset. When either \overline{CS} or \overline{RD} return to a high state, the DB0 through DB7 outputs are disabled (returned to the high-impedance state). The interrupt flip-flop remains reset.

IMPORTANT NOTICE

Texas Instruments and its subsidiaries (TI) reserve the right to make changes to their products or to discontinue any product or service without notice, and advise customers to obtain the latest version of relevant information to verify, before placing orders, that information being relied on is current and complete. All products are sold subject to the terms and conditions of sale supplied at the time of order acknowledgement, including those pertaining to warranty, patent infringement, and limitation of liability.

TI warrants performance of its semiconductor products to the specifications applicable at the time of sale in accordance with TI's standard warranty. Testing and other quality control techniques are utilized to the extent TI deems necessary to support this warranty. Specific testing of all parameters of each device is not necessarily performed, except those mandated by government requirements.

CERTAIN APPLICATIONS USING SEMICONDUCTOR PRODUCTS MAY INVOLVE POTENTIAL RISKS OF DEATH, PERSONAL INJURY, OR SEVERE PROPERTY OR ENVIRONMENTAL DAMAGE ("CRITICAL APPLICATIONS"). TI SEMICONDUCTOR PRODUCTS ARE NOT DESIGNED, AUTHORIZED, OR WARRANTED TO BE SUITABLE FOR USE IN LIFE-SUPPORT DEVICES OR SYSTEMS OR OTHER CRITICAL APPLICATIONS. INCLUSION OF TI PRODUCTS IN SUCH APPLICATIONS IS UNDERSTOOD TO BE FULLY AT THE CUSTOMER'S RISK.

In order to minimize risks associated with the customer's applications, adequate design and operating safeguards must be provided by the customer to minimize inherent or procedural hazards.

TI assumes no liability for applications assistance or customer product design. TI does not warrant or represent that any license, either express or implied, is granted under any patent right, copyright, mask work right, or other intellectual property right of TI covering or relating to any combination, machine, or process in which such semiconductor products or services might be or are used. TI's publication of information regarding any third party's products or services does not constitute TI's approval, warranty or endorsement thereof.