

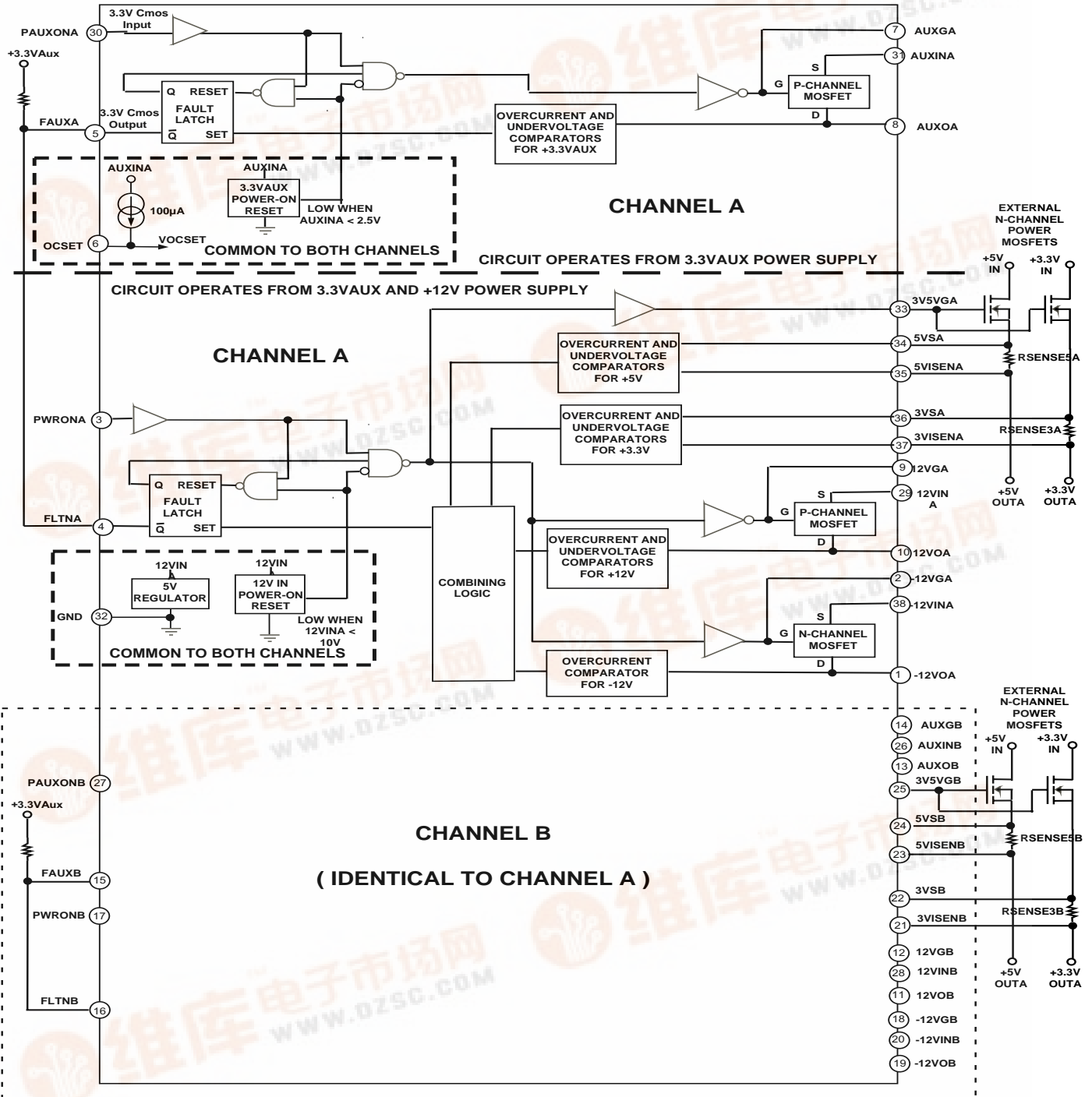

Dual PCI Hot-Plug™ Controller

Preliminary Technical Data

ADM1014



REV. PrN 1/02

Information furnished by Analog Devices is believed to be accurate and reliable. However, no responsibility is assumed by Analog Devices for its use, nor for any infringements of patents or other rights of third parties which may result from its use. No license is granted by implication or otherwise under any patent or patent rights of Analog Devices.

™ Hot Plug is a trademark of Core International, Inc.

One Technology Way, P.O. Box 9106, Norwood, MA 02062-9106, U.S.A.
Tel: 781/329-4700
www.analog.com
Fax: 781/329-0709

ADM1014–SPECIFICATIONS

FEATURES

Controls Two PCI Slots
 Controls all Four PCI Supplies, +3.3V, +5V, +12V, -12V, plus 3.3V auxiliary supply
 Internal MOSFET Switches for +3.3V AUX, +12V and -12V outputs
 Adjustable Overcurrent Protection for all Outputs
 Undervoltage Protection on +3.3V, +5V, +12V and +3.3V AUX Supplies
 Open-Drain Fault Output with Adjustable Delay
 Logic Control of Outputs
 Adjustable Soft-start

APPLICATIONS

Compact PCI
 PCI Hot-Plug™

GENERAL DESCRIPTION

The ADM1014 is a dual PCI voltage bus controller that allows hot-plugging of adapter cards into and out of an active or passive backplane. The device requires only four external power MOSFETs and a few discrete components for a complete power-control solution for two PCI slots.

The ADM1014 operates from a +12V and +3.3V AUX supply and controls five independent supplies (+3.3V, +3.3VAUX, +5V, +12V and -12V) on two separate channels (A and B). The power switches for the +3.3VAUX, +12V and -12V supplies are integrated onto the chip, and internal current limiting is provided. For the +3.3V and +5V supplies, the device drives external, N-channel, power MOSFETs, and provides overcurrent protection by sensing the voltage drop across external current-sense resistors.

The current limits for all 10 supplies are set by a single resistor to GND, connected to the OCSET pin.

Undervoltage sensing is provided on the +3.3V, +5V, +12V and +3.3VAux supplies. Overcurrent sensing is provided on all supplies. In the event of an overcurrent or undervoltage fault on any of the outputs of either channel, all outputs on that channel will be turned off.

Turn-on slew rate may be controlled using eight external capacitors, connected to the gate drives of all of the supplies.

Logic control of the four main outputs is provided by the PWRONA and PWRONB pins. When these pins are high, the outputs are turned on, when low, the outputs are turned off. The +3.3VAUX supplies have their own control inputs, PAUXA and PAUXB.

(Specifications are for each channel, 3.3VAUX=AUXINA=3.3V, $V_{CC} = 12VIN = +12V$, $-12VIN = -12V$, Nominal 3.3V and 5V supplies to external MOSFETs, $T_A = 0^\circ\text{C}$ to $+70^\circ\text{C}$, unless otherwise noted.)

Parameter	Min	Typ	Max	Units	Test Conditions/Comments
5V/ 3.3V SUPPLY CONTROL					
5V Overcurrent Threshold	-	8	-	A	See Typical Application Diagram
5V Overcurrent Threshold Voltage	33	42	50	mV	$V_{OCSET} = 0.6V$
5V Overcurrent Threshold Voltage	70	80	90	mV	$V_{OCSET} = 1.2V$
5V Undervoltage Trip Threshold	4.42	4.65	4.7	V	
5V Undervoltage Fault Response Time	-	110	160	ns	
5V Turn-On Time (PWRON High to 5VOUT = 4.75V)	-	9.75	-	ms	$C_{3V5VG} = 0.033\mu\text{F}$, $C_{5VOUT} = 2000\mu\text{F}$, $R_L = 1\Omega$
3V Overcurrent Threshold	-	10	-	A	See Typical Application Diagram
3V Overcurrent Threshold Voltage	41	52	62	mV	$OCSET = 0.6V$
3V Overcurrent Threshold Voltage	89	98	108	mV	$OCSET = 1.2V$
3V Undervoltage Trip Threshold	2.74	2.86	2.9	V	
3V Undervoltage Fault Response Time	-	110	160	ns	
3V5VG Undervoltage Enable Threshold Voltage	-	9.6	-	V	
3V Turn-On Time (PWRON High to 3VOUT = 3.00V)	-	9.75	-	ms	$C_{3V5VG} = 0.033\mu\text{F}$, $C_{3VOUT} = 2000\mu\text{F}$, $R_L = 0.43\Omega$
3V5VG Vout High	11.5	11.8	-	V	PWRON = High, FLTN = High
Gate Output Charge Current	19	25.0	29	μA	PWRON = High, $V_{3V5VG} = 4V$
Gate Turn-On Time (PWRON High to 3V5VG = 11V)	-	280	-	μs	$C_{3V5VG} = 0.033\mu\text{F}$, 3V5VG Rising 10% to 90%
Gate Turn-Off Time	-	2	-	μs	$C_{3V5VG} = 0.033\mu\text{F}$, 3V5VG Falling 90% to 10%
+12V SUPPLY CONTROL					
On Resistance of Internal PMOS	-	0.3	0.35	Ω	PWRON = High, $I_D = 0.5A$, $T_A = T_J = 25^\circ\text{C}$
On Resistance of Internal PMOS	-	0.35	0.5	Ω	PWRON = High, $I_D = 0.5A$, $T_A = T_J = 70^\circ\text{C}$
Overcurrent Threshold	0.6	0.75	0.9	A	$V_{OCSET} = 0.6V$
Overcurrent Threshold	1.25	1.50	1.8	A	$V_{OCSET} = 1.2V$
12V Undervoltage Trip Threshold	10.25	10.6	10.8	V	
Undervoltage Fault Response Time	-	110	-	ns	

ADM1014–SPECIFICATIONS (Continued)

(Specifications are for each channel, 3.3VAUX=AUXINA=3.3V, $V_{CC} = 12VIN = +12V$, $-12VIN = -12V$, Nominal 3.3V and 5V supplies to external MOSFETs, $T_A = 0^\circ\text{C}$ to $+70^\circ\text{C}$, unless otherwise noted.)

Parameter	Min	Typ	Max	Units	Test Conditions/Comments
Gate Charge Current	19	25.0	29	μA	PWRON = High, V 12VG = 10V
Turn-On Time (PWRON High to 12VG = 1V)	-	16	-	ms	$C_{12VG} = 0.033\mu\text{F}$, 12VG Falling 90% - 10%
Turn-Off Time	-	4.5	-	μs	$C_{12VG} = 0.033\mu\text{F}$, 12VG Rising 10% - 90%
-12V SUPPLY CONTROL					
On Resistance of Internal NMOS	-	0.7	1	Ω	PWRON = High, $I_D = 0.1\text{A}$, $T_A=T_J=25^\circ\text{C}$
On Resistance of Internal NMOS	-	1	1.3	Ω	PWRON = High, $I_D = 0.1\text{A}$, $T_A=T_J=70^\circ\text{C}$
Overcurrent Threshold	0.13	0.18	0.25	A	$V_{OCSET} = 0.6\text{V}$
Overcurrent Threshold	0.23	0.38	0.52	A	$V_{OCSET} = 1.2\text{V}$
Gate Output Charge Current	19	25	29	μA	PWRON = High, $V_{M12VG} = -10\text{V}$
Turn-On Time (PWRON High to M12VO = -10.8V)	-	16	-	ms	$C_{M12VG} = 0.033\mu\text{F}$, $C_{M12VO} = 50\mu\text{F}$, $R_L = 120\Omega$
Turn-Off Time	-	3	-	μs	$C_{M12VG} = 0.033\mu\text{F}$, M12VG Falling 90% - 10%
M12VIN Input Bias Current	-	2.5	5	mA	PWRON = High
+3.3VAUX SUPPLY CONTROL					
On Resistance of Internal PMOS	-	0.25	TBD	Ω	PAUXON = High, $I_D = 0.375\text{A}$, $T_A=T_J=25^\circ\text{C}$
On Resistance of Internal PMOS	-	0.25	TBD	Ω	PAUXON = High, $I_D = 0.375\text{A}$, $T_A=T_J=70^\circ\text{C}$
Overcurrent Threshold	-	0.5	TBD	A	$V_{OCSET} = 0.6\text{V}$
Overcurrent Threshold	-	1.0	TBD	A	$V_{OCSET} = 1.2\text{V}$
3.3VAUX Undervoltage Trip Threshold	-	2.9	TBD	V	
Undervoltage Fault Response Time	-	110	-	ns	
Gate Charge Current	19	25.0	29	μA	PAUXON = High, $V_{AUXG} = 3\text{V}$
Turn-On Time (PAUXON High to AUXG = 1V)	-	16	-	ms	$C_{AUXG} = 0.033\mu\text{F}$
Turn-Off Time	-	3	-	μs	$C_{AUXG} = 0.033\mu\text{F}$, AUXG Rising 10% - 90%
3.3VAUX Power On Reset Threshold	-	2.5	-	V	AUXIN Voltage Rising
CONTROL PINS					
12VIN Supply Current	-	5.3	8	mA	
AUXIN Supply Current	-	3	TBD	mA	
OCSET Current	93	100	107	μA	
Overcurrent to Fault Response Time	-	500	960	ns	
PWRON/A/B, PAUXA/B Threshold Voltage	1.0	1.6	2.1	V	
12V Power On Enable Threshold	9.4	10	10.2	V	12VINA Voltage Rising
12V Power On Reset Threshold	8.9	9.1	9.3	V	12VINA Voltage Falling
FAULT O/P PINS					
$\overline{\text{FLTA}}/\overline{\text{B}}$ Output Low Voltage	-	0.5	0.7	V	$I_{\overline{\text{FLT}}} = 2\text{mA}$
$\overline{\text{FLTA}}/\overline{\text{B}}$ Output High Voltage	AUXIN-0.5	AUXIN-0.1	-	V	$I_{\overline{\text{FLT}}} = 0$
$\overline{\text{FLTA}}/\overline{\text{B}}$ Output Latch Threshold	TBD	1.6	TBD	V	$I_{\overline{\text{FLT}}}$ High to Low transition
$\overline{\text{FAUXA}}/\overline{\text{B}}$ Output Low Voltage	-	0.5	0.7	V	$I_{\overline{\text{FAUX}}} = 2\text{mA}$
$\overline{\text{FAUXA}}/\overline{\text{B}}$ Output High Voltage	AUXIN-0.5	AUXIN-0.1	-	V	$I_{\overline{\text{FAUX}}} = 0$
$\overline{\text{FAUXA}}/\overline{\text{B}}$ Output Latch Threshold	TBD	1.6	TBD	V	$I_{\overline{\text{FAUX}}}$ High to Low transition

NOTES

Specifications subject to change without notice.

ADM1014–SPECIFICATIONS

ABSOLUTE MAXIMUM RATINGS*

(T_A = +25°C unless otherwise noted)

V _{CC} , 12VIN	-0.5V to +14.0V
12VO, 12VG, 3V5VG	-0.5V to V _{12VIN} +0.5V
-12VIN	-14.0V to +0.5V
-12VO, -12VG	V _{-12VIN} -0.5V to +0.5V
3VISEN, 5VISEN	-0.5V to the Lesser of 12VIN or +7.0V
Voltage, Any Other Pin	-0.5V to +7.0V
12VO Output Current	3A
-12VO Output Current	0.8A
Continuous Power Dissipation (T _A = +70°C)	667mW
TSSOP (derate 8.3mW/oC above +70°C)	

Operating Temperature Range

Commercial (J Version) 0°C to +70°C

Storage Temperature Range -65°C to +150°C

Lead Temperature (Soldering, 10 sec) +300°C

*This is a stress rating only and functional operation of the device at these or any other conditions above those indicated in the operation sections of this specification is not implied. Exposure to absolute maximum rating conditions for extended periods of time may affect reliability.

THERMAL CHARACTERISTICS

38-Pin TSSOP Package:

θ_{JA} = 100°C/Watt, θ_{JC} = 10°C/Watt

ORDERING GUIDE

Model	Temperature Range	Package Description	Package Option
ADM1014JRU	0°C to +70°C	38-Pin TSSOP	RU-38

PIN CONFIGURATION

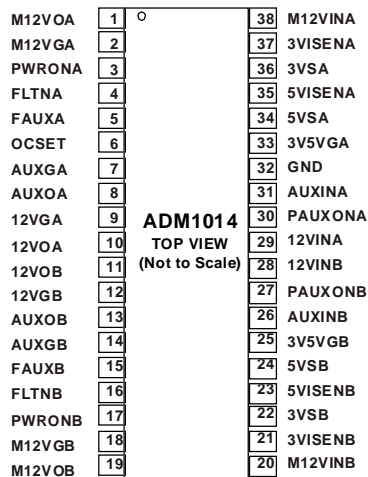

PIN FUNCTION DESCRIPTION

Pin	Mnemonic	Function
1	M12VOA	Switched -12V output for channel A. Rated for 100mA.
2	M12VGA	Gate of channel A internal NMOS transistor. A capacitor connected from this pin to -12VOA (pin 1) sets the start-up ramp for the +12V supply. During turn-on, this capacitor is charged from a 25 μ A current source.
3	PWRONA	Power on control for channel A. 3.3V CMOS-compatible logic input controls all four main supplies. PWRONA high = outputs on, PWRONA low = outputs off.
4	FLTNA	Active-low, 5V compatible, Open Drain fault output for channel A. A pull-up resistor connects the pin to 3.3VAux. 4.7k Ω is recommended for this function. An optional capacitor may be connected from this pin to GND to provide improved immunity to power supply transients.
5	FAUXA	Active-low, 3.3V compatible, Open Drain fault output for Aux channel A. The same pull-up resistor as that on FLTNA connects the pin to 3.3VAux.
6	OCSET	Overcurrent set for all 10 outputs. A resistor connected from this pin to ground sets the overcurrent trip point of all eight supplies. All eight overcurrent trip-points can be programmed by changing the value of this resistor. The default value of 6.04k Ω , $\pm 1\%$ is compatible with the maximum currents allowed by the PCI specification.
7	AUXGA	Gate of channel A +3.3VAUX internal PMOS transistor. A capacitor connected from this pin to AUXOA (pin 8) sets the start-up ramp for the +3.3VAUX supply. During turn-on, this capacitor is charged from a 25 μ A current source.
8	AUXOA	Switched 3.3V auxiliary output for channel A. Rated for 0.375A.
9	12VGA	Gate of channel A internal PMOS transistor. A capacitor connected from this pin to 12VOA (pin 10) sets the start-up ramp for the +12V supply. During turn-on, this capacitor is charged from a 25 μ A current source. The undervoltage circuitry is disabled when the voltage on 12VGA rises above 1.2V. If the capacitor on pin 7 (AUXGA) or pin 33 (3V5VGA) is more than 25% larger than the capacitor on pin 9 (12VGA) a false undervoltage condition may be detected during startup.
10	12VOA	Switched 12V output for channel A. Rated for 0.5A.
11	12VOB	Switched 12V output for channel B. Rated for 0.5A.
12	12VGB	Gate of channel B internal PMOS transistor. A capacitor connected from this pin to 12VOB (pin 11) sets the start-up ramp for the +12V supply. During turn-on, this capacitor is charged from a 25 μ A current source. The undervoltage circuitry is disabled when the voltage on 12VGB rises above 1.2V. If the capacitor on the pin 25 (3V5VGB) or pin 14 (AUXGB) is more than 25% larger than the capacitor on pin 12 (12VGB) a false undervoltage condition may be detected during startup.
13	AUXOB	Switched 3.3V auxiliary output for channel B. Rated for 0.375A.
14	AUXGB	Gate of channel B +3.3VAUX internal PMOS transistor. A capacitor connected from this pin to AUXOB (pin 13) sets the start-up ramp for the +3.3VAUX supply. During turn-on, this capacitor is charged from a 25 μ A current source.
15	FAUXB	Active-low, 3.3V compatible, Open Drain fault output for Aux channel B. The same pull-up resistor as that on FLTNA connects the pin to 3.3VAux.
16	FLTNB	Active-low, 5V compatible, Open Drain fault output for channel B. A pull-up resistor connects the pin to 3.3VAux. 4.7k Ω is recommended for this function. An optional capacitor may be connected from this pin to GND to provide improved immunity to power supply transients.
17	PWRONB	Power on control for channel B. 3.3V CMOS-compatible logic input controls all four main supplies. PWRONB high = outputs on, PWRONB low = outputs off.
18	M12VGB	Gate of channel B internal NMOS transistor. A capacitor connected from this pin to -12VOB (pin 19) sets the start-up ramp for the +12V supply. During turn-on, this capacitor is charged from a 25 μ A current source.
19	M12VOB	Switched -12V output for channel B. Rated for 100mA.

PIN FUNCTION DESCRIPTION (CONTINUED)

Pin	Mnemonic	Function
20	M12VINB	-12V supply input for channel B. Also provides power to the -12V overcurrent circuitry.
21	3VISENB	3.3V current sense for channel B. A current-sensing resistor is connected between this pin and 3VSB (pin 22). Connect to the load side of the current sense resistor.
22	3VSB	3.3V source for channel B. The source of the 3.3V MOSFET is connected to this pin and a current-sensing resistor is connected between this pin and pin 21.
23	5VISENB	5V current sense for channel B. A current-sensing resistor is connected between this pin and 5VSB (pin 24). Connect to the load side of the current sense resistor.
24	5VSB	5V source for channel B. The source of the 5V MOSFET is connected to this pin and a current-sensing resistor is connected between this pin and pin 23.
25	3V5VGB	3.3V and 5V gate output for channel B, drives the gates of the external 3.3V and 5V MOSFETs. A capacitor connected from this pin to GND sets the start-up ramp for the 3.3V and 5V supplies. During turn-on, this capacitor is charged from a 25 μ A current source. The undervoltage circuitry is disabled when the voltage on 3V5VGB falls below 12VIN-1.2V.
26	AUXINB	+3.3V auxiliary supply input for channel B.
27	PAUXONB	Power on control for channel B +3.3V auxiliary output. 3.3V CMOS-compatible logic input. PAUXONB high = outputs on, PAUXONB low = outputs off.
28	12VINB	Switched +12V supply input for channel B.
29	12VINA	Switched +12V supply input for channel A and for OCSET and power-on RESET circuits.
30	PAUXONA	Power on control for channel A +3.3V auxiliary output. 3.3V CMOS-compatible logic input. PAUXONA high = outputs on, PAUXONA low = outputs off.
31	AUXINA	+3.3V auxiliary supply input for channel A.
32	GND	Ground for all chip circuits. Connect to common of power supplies.
33	3V5VGA	3.3V and 5V gate output for channel A, drives the gates of the external 3.3V and 5V MOSFETs. A capacitor connected from this pin to GND sets the start-up ramp for the 3.3V and 5V supplies. During turn-on, this capacitor is charged from a 25 μ A current source. The undervoltage circuitry is disabled when the voltage on 3V5VGA falls below 12VIN-1.2V.
34	5VSA	5V source for channel A. The source of the 5V MOSFET is connected to this pin and a current-sensing resistor is connected between this pin and pin 35.
35	5VISENA	5V current sense for channel A. A current-sensing resistor is connected between this pin and 5VSA (pin 34). Connect to the load side of the current sense resistor.
36	3VSA	3.3V source for channel A. The source of the 3.3V MOSFET is connected to this pin and a current-sensing resistor is connected between this pin and pin 37.
37	3VISENA	3.3V current sense for channel A. A current-sensing resistor is connected between this pin and 3VSA (pin 36). Connect to the load side of the current sense resistor.
38	M12VINA	-12V supply input for channel A. Also provides power to the -12V overcurrent circuitry.

ADM1014

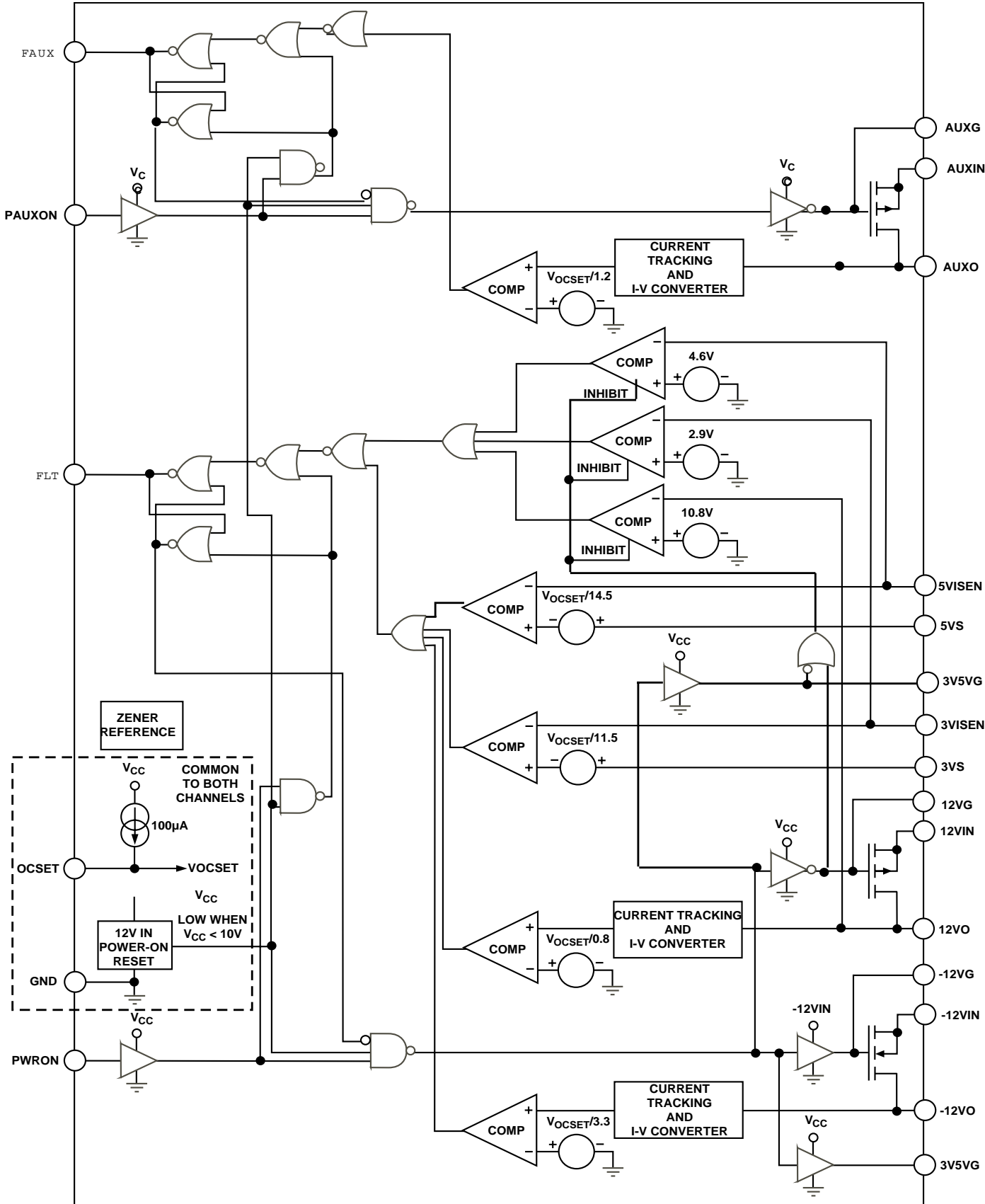

CIRCUIT OF ONE CHANNEL SHOWN, BOTH CHANNELS ARE IDENTICAL. RESET AND OCSET CIRCUITRY WITHIN DASHED LINE IS COMMON TO BOTH CHANNELS

Figure 1. Simplified Schematic

ADM1014

FUNCTIONAL DESCRIPTION

VOLTAGE OUTPUTS

The ADM1014 consists of two independent, identical channels, A and B, each of which controls four main power supply voltages and an auxiliary voltage. As the channels are identical, the following description applies to either channel, except where otherwise stated.

An on-chip PMOS transistor connected between 12VIN and 12VO switches the +12V supply at currents up to 1.5A, whilst an on-chip NMOS transistor connected between -12VIN and -12VO switches the -12V supply at currents up to 0.38A. The +3.3V and +5V supplies are switched by external, N-channel MOSFETs, whose gate drive is provided by the 3V5VG pins. Using suitable MOSFETs, singly or in parallel, currents of several amps may be switched with very low voltage drops.

The four main power supplies may be switched on and off under control of the PWRON pin.

The 3.3V auxiliary supply has an on-chip PMOS transistor, which can switch currents at up to 1A. This supply is controlled independently of the other four supplies by the PAUXON pin.

All five supplies are protected against overcurrent and the four positive supplies are also protected against undervoltage.

EXTERNAL CURRENT LIMIT

The external power MOSFETs are protected and overcurrent shutdown is provided on the +3.3V and +5V supplies by external current-sense resistors and on-chip comparators.

Current-sensing resistors are connected between the +5V output pin and the 5VISEN pin, and between the +3.3V output pin and the 3.3VISEN pin. The sense pins are connected to the inverting inputs of the current-limit comparator directly, while the voltage outputs are connected to the non-inverting inputs via a reference voltage proportional to the voltage on the OCSET pin. This voltage is $V_{OCSET}/14.5$ in the case of the 5V output and $V_{OCSET}/11.5$ in the case of the 3.3V output. These values were chosen so that the 3.3V and 5V sense resistors could both be 5m Ω in PCI applications.

When the voltage drop across the current-sensing resistor exceeds the reference voltage, the output of the comparator will go high, the fault latch will be set and all four main outputs and the auxiliary output on the channel will be turned off. The other main channel and auxiliary channel will remain on.

The reference voltages for the current-limit comparators are set by connecting a resistor between the OCSET pin and GND. An on-chip, 100 μ A current source generates a voltage across this resistor. The current limit may also be adjusted by the choice of current-sensing resistor.

$$\begin{aligned} I_{LIMIT}(3.3V) &= V_{OCSET}/(11.5 \times R_{SENSE3}) \\ &= (R_{SET} \times 10^{-4})/(11.5 \times R_{SENSE3}) \\ I_{LIMIT}(5V) &= V_{OCSET}/(14.5 \times R_{SENSE5}) \\ &= (R_{SET} \times 10^{-4})/(14.5 \times R_{SENSE5}) \end{aligned}$$

Where:

I_{LIMIT} = current limit in Amps

R_{SET} is resistor from OCSET to GND in Ω

R_{SENSE} is current-sense resistor in Ω

Note: The OCSET current source obtains its power supply from 12VINA.

INTERNAL CURRENT LIMIT

The +3.3VAUX, +12V and -12V supplies have the power MOSFET switches on-chip. These devices are protected and overcurrent shutdown is provided by a completely self-contained current sensing system. The output current through the on-chip power MOSFET is tracked at a lower level by a second, smaller MOSFET. The current through this MOSFET is then converted to a voltage, which is compared to a reference voltage determined by R_{SET} . In the case of the +12V and -12V outputs, if the current-sense voltage exceeds this reference voltage, the comparator output will go high, the fault latch will be set and all four main outputs and the auxiliary output will be turned off. Similarly in the case of the auxiliary output, if the current-sense voltage exceeds the reference voltage, the comparator output will go high, the fault latch will be set, FAUXN/FLTIN will go low, and the auxiliary output and the four main outputs will turn off.

The typical internal limiting currents may be calculated as follows:

$$\begin{aligned} I_{LIMIT}(+3.3VAUX) &= V_{OCSET}/1.2 \\ &= (10^{-4} \times R_{SET})/1.2 \\ I_{LIMIT}(+12V) &= 1.25 \times V_{OCSET} \\ &= 1.25 \times 10^{-4} \times R_{SET} \\ I_{LIMIT}(-12V) &= V_{OCSET}/3.3 \\ &= (10^{-4} \times R_{SET})/3.3 \end{aligned}$$

Where:

I_{LIMIT} = current limit in Amps

R_{SET} is resistor from OCSET to GND in Ω

Due to tolerances in the current tracking FETs, the variations in the internal current limit are quite wide, typically $\pm 20\%$ of the calculated value for the +12V supply and $+35\%$ - 20% of the calculated value for the -12V supply.

CHOICE OF R_{SET} AND R_{SENSE}

Using the above equations, R_{SET} is chosen to set the required current limits for the +3.3VAUX, +12V and -12V supplies. Once R_{SET} has been chosen, R_{SENSE3} and R_{SENSE5} can be chosen to set the current limits for the 3.3V and 5V outputs.

For PCI applications R_{SET} should be 6.04k Ω and the current sense resistors should both be 5m $\Omega \pm 1\%$. This will set the current limits to the maximum values for the PCI specification. For other applications, the following limits should be noted.

1. The minimum value of R_{SET} is limited by the minimum voltage the current-limit comparators can reliably sense, which is determined by noise, comparator offset voltage and the overdrive required to switch the comparator. The reference voltage set by R_{SET} should not be less than 33mV for the 5V output, which has the smallest reference voltage. The minimum recommended value for R_{SET} is 6k Ω , which gives a reference voltage of 35mV for the 5V output and 45mV for the 3.3V output.
2. The maximum value of R_{SET} is limited by the junction temperature. This is determined by the power dissipated in the on-chip MOSFETs, (which is dependent upon the current passed

by the devices and their on-resistance), the thermal resistance of the package (100°C/W), and the ambient temperature.

The maximum on-resistance of the +3.3VAUX MOSFET is 0.65Ω, that of the +12V MOSFET is 0.35Ω and that of the -12V MOSFET is 0.9Ω, so the power dissipation will be:

$$P_D = (0.65 \times (I_{+3.3VAUX})^2 + 0.35 \times (I_{+12V})^2 + 0.9 \times (I_{-12V})^2)$$

Where:

P_D is power dissipation in Watts

I is current in Amps

Under normal operating conditions the maximum recommended value for R_{SET} is 15kΩ.

UNDERVOLTAGE SENSING

Undervoltage sensing of the +3.3V, +5V, +12V and +3.3VAUX supplies is carried out by four voltage comparators. The supply voltages being monitoring are applied to the inverting inputs of these comparators, whilst reference voltages of 2.9V, 4.6V, 10.8V and 2.9V (derived from an on-chip zener reference) are applied to their non-inverting inputs. Should any of the output voltages fall below the corresponding reference voltage, the output of the comparator will go high, the fault latch will be set, turning off all the supplies (main and auxiliary) on that channel.

FLTN AND FAUXN OUTPUTS

The FLTN and FAUXN outputs are active-low, 3.3V compatible, Open- Drain fault outputs. These outputs are shorted together and then connected to the 3.3VAux supply using a 4.7kΩ pull-up resistors. Should an overcurrent or undervoltage event occur on one of the supplies, main or auxiliary, then the fault latch will be set, FLTA and FAUXA or FLTB and FAUXB will go low and all outputs on the faulting channel will be turned off.

PROGRAMMABLE FAULT LATCH DELAY

The delay between an overcurrent or undervoltage fault occurring and the outputs shutting down may be set by connecting a capacitor between a FLTN or FAUXN output and GND. This delays the start of the FLTN/FAUXN output 1 to 0 transition and slows down the fall time of the FLTN/FAUXN output, thus delaying shutdown of the outputs. If the fault latch threshold (~1.6V) is reached on FLTN/FAUXN then the fault latch will be set and the four supply outputs and the auxiliary output will be shut down. If the fault disappears before the latching threshold is reached, the fault latch will not be set and the FLTN/FAUXN output will return to a high state.

This adjustable delay allows the ADM1014 to ignore overcurrent and undervoltage transients that might otherwise cause an unwanted shutdown. It should be noted that if a fault is asserted on FLTN and FAUXN at the same time, then the delay is halved, as shown in fig. 2 and Table 1.

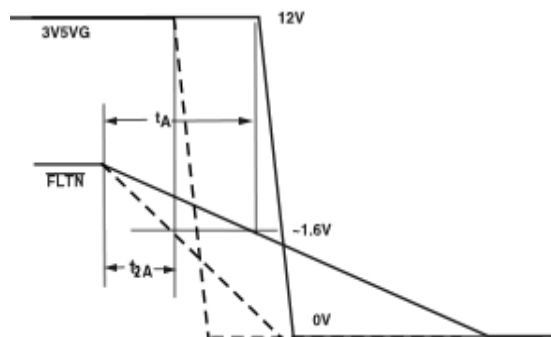

Figure 2. FLTN and 3V5VG Delay

TABLE 1. FLT AND 3V5VG DELAY VS. C_{FLT}

C_{FLT}	t_A	t_{2A}
OPEN	0.1μs	0.05μs
0.001μF	0.44μs	0.22μs
0.01μF	2.9μs	1.5μs
0.1μF	28μs	14μs

POWER CONTROL INPUTS

The PWRONA and PWRONB inputs are 3.3V CMOS-compatible logic inputs, which may be used to switch all four main outputs on and off, and is also used to reset the fault latch and turn the outputs back on after an overcurrent or undervoltage shutdown.

When PWRON is high, the four main supplies are turned on. With PWRON held low, the supplies are turned off. After an overcurrent or undervoltage shutdown, PWRON should be toggled low then high again to reset the fault latch and turn on the outputs.

PAUXONA and PAUXONB are also 3.3V CMOS-compatible logic inputs which perform a similar function for the +3.3V auxiliary supplies.

POWER-ON SEQUENCE AND SOFT START

When the device is powered on with PWRON held high, the outputs are inhibited by the power-on reset circuit and will not become active until V_{CC} exceeds 10V. During this time the undervoltage comparators are inhibited and the fault latch is held in a reset condition.

Note: the power-on reset circuit monitors 12VINA.

After the power-on delay, all five outputs are turned on simultaneously. The undervoltage comparators are enabled when the voltage on the gate of the internal PMOS transistor, 12VG, has fallen below about 400mV.

The rise time of the outputs may be controlled by connecting capacitors between the gate and output pins of the +3.3VAUX, +12V and -12V outputs, and from the 3V5VG pin to GND. During output turn-on, these capacitors are charged from a nominal 25μA current source. Limiting the output rise times also limits the charging currents drawn by any supply decoupling capacitors in the circuits being driven. With fast turn-on these currents might be excessive and cause overcurrent faults at power-on.

Care must be taken when choosing these capacitors. If the capacitor on AUXG or 3V5VG is more than 25% larger than

ADM1014

the capacitor on 12V_G, the +3.3V_{AUX}, 3.3V and 5V outputs may not have exceeded their undervoltage thresholds by the time the undervoltage comparators are enabled, and a false undervoltage condition may be detected. For this reason it is recommended to use the same value for all three gate capacitors.

For PCI applications the minimum recommended value is 0.033μF. Smaller values may cause overcurrent faults at power-up due to excessive charging currents drawn by decoupling capacitors.

The maximum value of the gate capacitors is determined by the need to discharge them quickly when turning off the outputs under fault conditions. If the capacitors are too large the ADM1014 may be unable to protect the power bus or the external MOSFETs. With 0.033μF capacitors, the turn-off time will be less than 6μs.

APPLICATIONS INFORMATION

APPLICATION CIRCUIT

Figure 3 shows a typical circuit configuration for the ADM1014 in a PCI application, controlling supply voltages of +3.3V at up to 7.6A, +5V at up to 5A, +12V at up to 0.5A and -12V at up to 0.1A. In this circuit, two external MOSFETs are connected in parallel for the 3.3V and 5V outputs to minimise on-resistance.

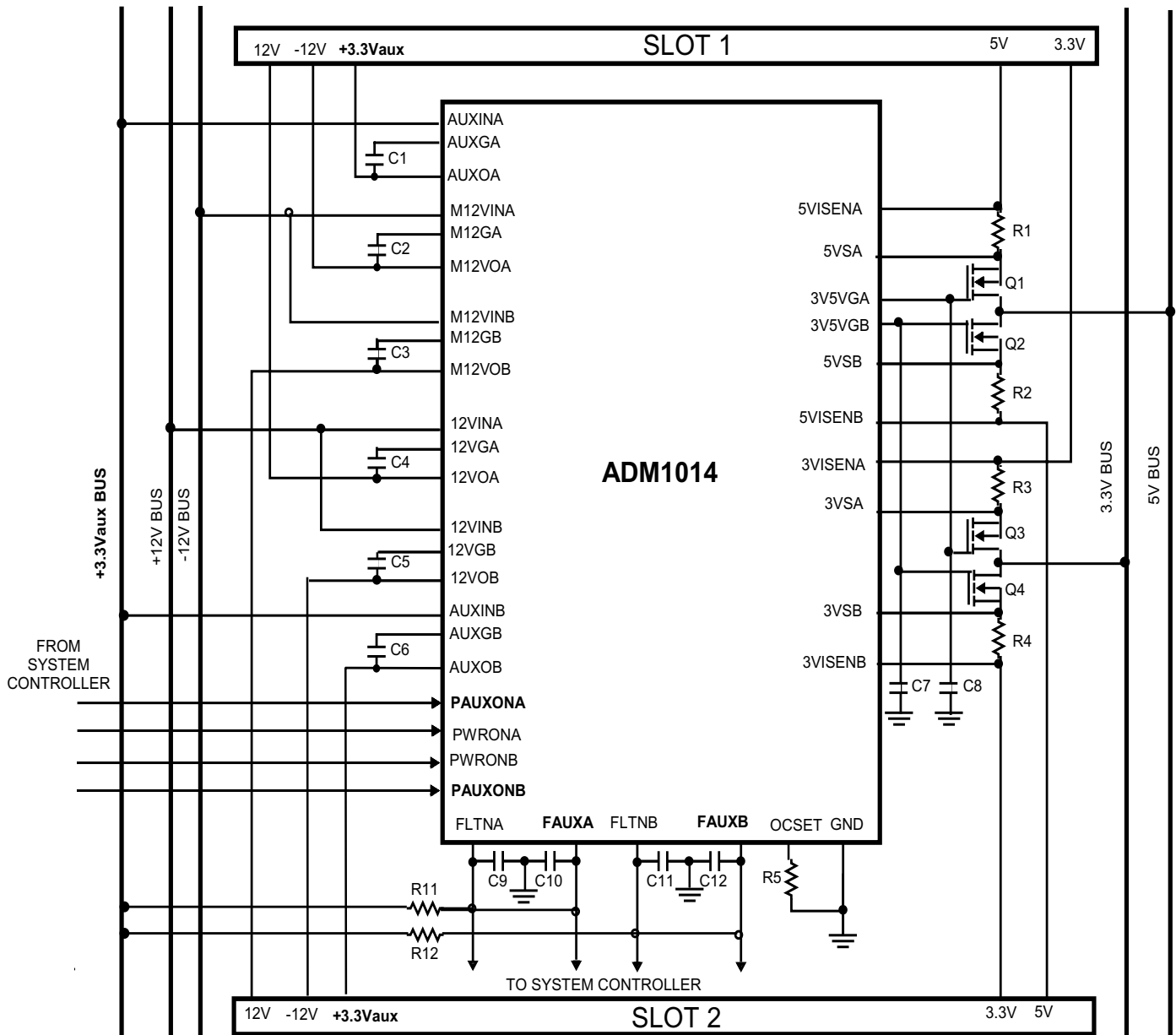

Figure 3. Typical Application Circuit

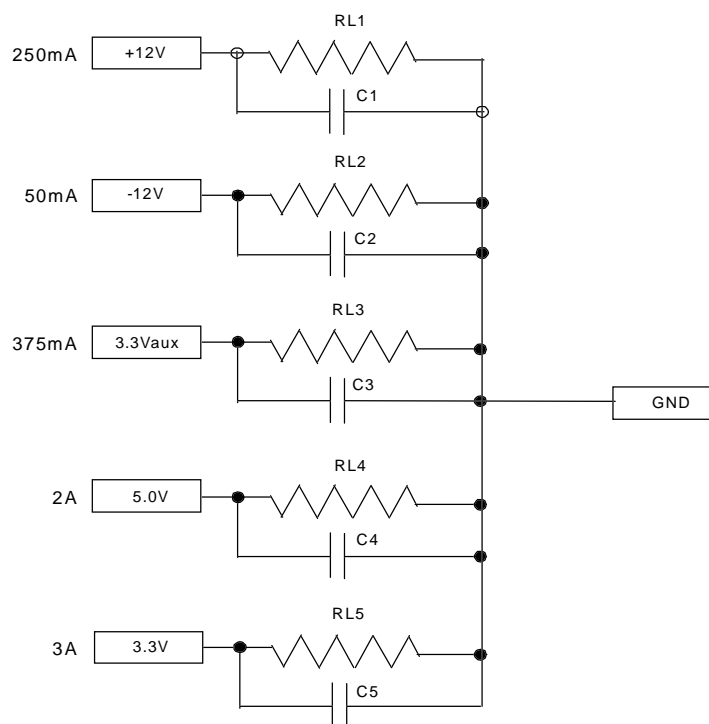

Figure 4. Load Board for Typical Application Circuit

Main Board Components

Item	Qty	Ref Des	Description
1	1	U1	ADM1014
2	1	SKT1	38 Pin Tssop Socket
3	4	Q1-4	IRF7413 Power Mosfet
4	4	D1-4	Green SMD LED
5	4	R1-4	5mΩ Metal Strip Resistor
6	2	R5-6	470Ω 0805 chip resistor
7	2	R7-8	1K5Ω 0805 chip resistor
8	2	R9-10	6K04Ω 0805 chip resistor
9	8	C1-8	CAP,0.033UF
10	4	C9-12	CAP,0.47UF
11	3	C13-15	Electrolytic capacitor space
12	1	S1	SPDT Slide Switch
13	8	T1-8	Testpoint
14	2	P1-2	20 Pin Edge Conn Skt
15	4	J1 J4-J6	4mm 10A PCB Sockets-Red
16	1	J2	4mm 10A PCB Sockets-Green
17	1	J3	4mm 10A PCB Sockets-Black
18	4	P4-7	SMB
19	1	PCB	EVAL-ADM1014 Main Board
20	4	R11-12	4K7Ω 0805 chip resistor
21	2	Load Board	Fully Assembled Load Board

Load Board Components

Item	Qty	Ref Des	Description
1	1	PCB	EVAL-ADM1014Load Board
2	3	CL1-CL3	100uF 16V Electrolytic Caps
3	2	CL4-CL5	2200uF 16V Electrolytic Caps
4	1	RL1	47Ω 6W (W22 Series) Res
5	1	RL2	240Ω 2.5W (W21 Series) Res
6	1	RL3	10Ω 6W (W22 Series) Res
7	1	RL4	2.2Ω 12W (W24 Series) Res
8	1	RL5	1Ω 12W (W24 Series) Res

ADM1014

LAYOUT CONSIDERATIONS

Any circuits supplied by the ADM1014 are outside the control loops of the main system power supplies, which means that any series resistance between the four supply inputs and the outputs will cause a degradation of the supply load regulation. This includes connector contact resistance, PCB trace resistance, on-resistance of MOSFETs (both external and on-chip) and current sense resistors.

Care must therefore be taken to ensure that:

- a) PCB traces are as heavy as possible.
- b) External MOSFETs have low-on resistance.
- c) Current sense resistors are as small as possible.

The current sense resistors have very small values ($5\text{m}\Omega$ in the preceding example) to minimise the voltage drop across them. Because of this, PCB trace resistance can be a significant percentage of the sense resistance. It is therefore essential to ensure that the ADM1014 senses the voltage drop directly across the sense resistors and not across any current-carrying trace resistance in series with them. Connections from the ADM1014 to the sense resistors must go directly to the ends of the resistors. Figure 4 shows examples of good and bad practice

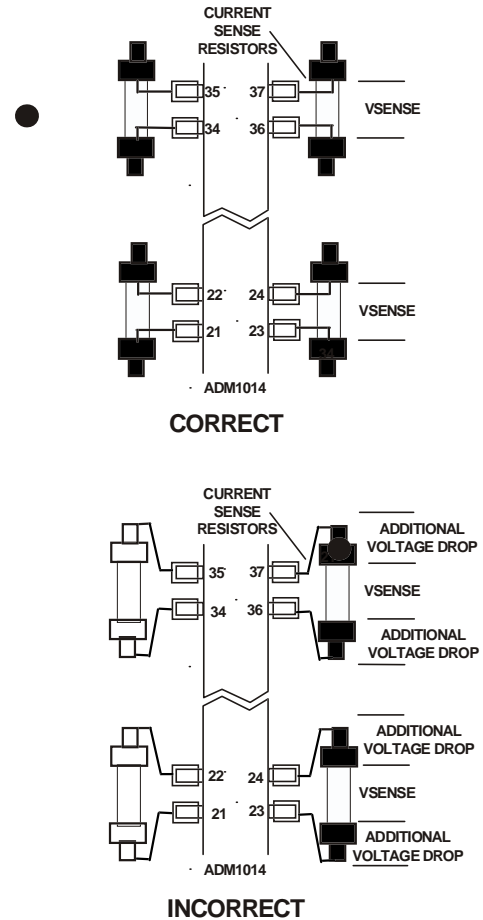

Figure 4. Good and Bad Practice For Sense Resistor Connection

OUTLINE DIMENSIONS

Dimensions shown in inches and (mm).

38-Pin TSSOP (RU-38)

