

PolySwitch Automotive

Resettable Devices

Raychem has provided PPTC resettable devices in the automotive industry for over twenty years. Until recently, the products sold by Raychem to this industry were either custom products (TD and Chip series devices) or our standard commercial versions of PPTC resettable devices. With the advent of QS-9000 and our continued involvement in the automotive industry, we were asked to develop automotive-specific versions of our PPTC resettable devices. The result of that work is the four device series (AHS, ASMD, AHR and AGR) featured in this section (as well as adding other products to the automotive qualification on an ongoing basis). These products

are qualified and sold under our PS400 specification which is derived from AEC-Q200, the standard for electronic components used in the automotive industry. The key difference of these products is the rigorous additional testing these devices have successfully passed to meet the demanding environmental conditions that can be found in automotive applications, and the addition of new specification values which characterize the products' performance after being subjected to these specified environmental and electrical stress conditions.

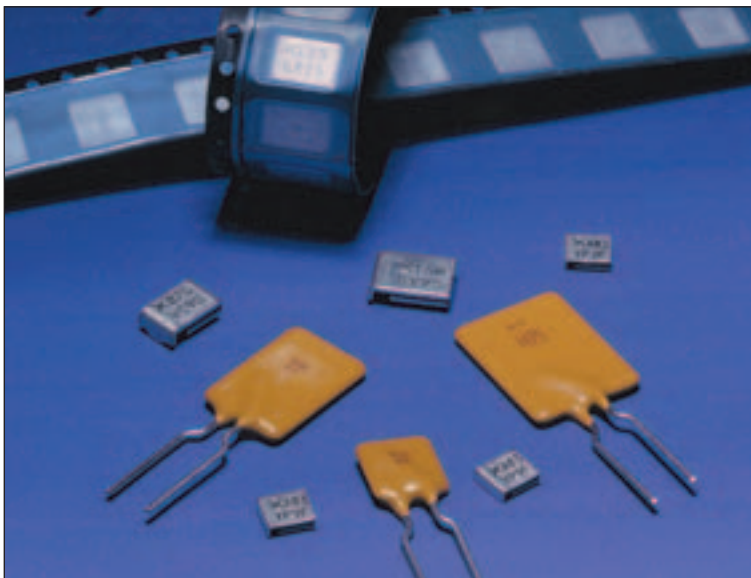

4

Benefits:

- Many product choices give engineers more design flexibility
- Compatible with high volume electronics assembly
- Assists in meeting regulatory requirements
- Higher voltage ratings allow use in new applications

Features:

- Wide range of resettable devices for the automotive industry
- Current ratings from 0.3A to 15A
- Voltage ratings from 15V to 60V
- Meets automotive industry standards
- Fast time-to-trip
- Low resistance

Applications:

- Electronic control modules
- Automotive small and medium motors
- Junction boxes
- Lamp protection
- Power outlet protection
- Powered antennae
- Telematics powered components protection
- HVAC and climate control

Devices in this section are grouped by:

Form Factor, Product Series, Hold Current

4

Step 1. Determine the circuit’s operating parameters.

Fill in the following information about the circuit:

Maximum ambient operating temperature _____

Normal operating current _____

Maximum operating voltage
(i.e. AGR400 is 16V_{MAX}*) _____

Maximum interrupt current _____

Step 2. Select the PolySwitch device that will accommodate the circuit’s maximum ambient temperature and normal operating current.

Look across the top of Table A2 to find the temperature that most closely matches the circuit’s maximum operating temperature. Look down that column to find the value equal to or greater than the circuit’s normal operating current. Now look to the far left of that row to find the part number for the PolySwitch device that will best accommodate the circuit. Devices in this section are grouped by form factor, therefore your operating current requirement may be found in more than one product grouping.

The thermal derating curves located in Figures A1 and A2 are the normalized representations of the data in Table A2.

Step 3. Compare the selected device’s maximum electrical ratings with the circuit’s maximum operating voltage and maximum interrupt current.

Look down the first column of Table A3 to find the part number you selected in Step 2. Look to the right in that row to find the device’s maximum operating voltage (V_{MAX}) and maximum interrupt current (I_{MAX}). Ensure that V_{MAX} and I_{MAX} are greater than or equal to the circuit’s maximum operating voltage and maximum interrupt current.

Step 4. Determine time-to-trip.

Time-to-trip is the amount of time it takes for a device to switch to a high-resistance state once a fault current has been applied across the device. Identifying the PolySwitch device's time-to-trip is important in order to provide the desired protection capabilities. If the device you choose trips too fast, undesired or nuisance tripping will occur. If the device trips too slowly, the components being protected may be damaged before the device switches to a high-resistance state.

Refer to the typical time-to-trip curves for each of the PolySwitch devices found in Figures A8-A11.

If the PolySwitch device's time-to-trip is too fast or too slow for the circuit, go back to Step 2 and choose an alternate device.

Step 5. Verify ambient operating conditions.

Ensure that your application's minimum and maximum ambient temperatures are within the operating temperature of -40°C to 85°C (-40°C to 125°C for AHR, AHS series devices).

Step 6. Verify the PolySwitch device dimensions.

Using dimensions in Table A4, compare the dimensions of the PolySwitch device you selected with the application's space considerations.

Table A1. Product Series – Current Rating, Voltage Rating/Typical Resistance for Automotive Devices

	AGR	AHR	AHS	ASMD		
Voltage Rating	16V	16V	16V	15V	30V	60V
Hold Current (A)						
0.30	—	—	—	—	—	0.23Ω
0.50	—	—	—	—	—	0.90Ω
0.75	—	—	—	—	0.60Ω	—
0.80	—	—	0.25Ω	—	—	—
1.00	—	—	—	—	0.30Ω	—
1.25	—	—	—	0.16Ω	—	—
1.50	—	—	—	0.16Ω	—	—
1.60	—	—	0.10Ω	—	—	—
2.00	—	—	—	0.09Ω	—	—
2.50	—	—	—	0.06Ω	—	—
4.00	0.030Ω	—	—	—	—	—
4.50	—	0.029Ω	—	—	—	—
5.00	0.0192Ω	—	—	—	—	—
6.00	0.0145Ω	0.018Ω	—	—	—	—
6.50	—	0.014Ω	—	—	—	—
7.00	0.0105Ω	—	—	—	—	—
7.50	—	0.012Ω	—	—	—	—
8.00	0.0086Ω	—	—	—	—	—
9.00	0.0070Ω	0.010Ω	—	—	—	—
10.00	0.0056Ω	0.0083Ω	—	—	—	—
11.00	0.0050Ω	—	—	—	—	—
12.00	0.0046Ω	—	—	—	—	—
13.00	—	0.0055Ω	—	—	—	—
14.00	0.0040Ω	—	—	—	—	—
15.00	—	0.0048Ω	—	—	—	—

Table A2. Thermal Derating for Automotive Devices [Hold Current (A) at Ambient Temperature (°C)]

Part Number	Maximum Ambient Temperature										
	-40°C	-20°C	0°C	20°C	25°C	40°C	50°C	60°C	70°C	85°C	125°C
AGR (AGRF for Pb-free version of product)											
16V—Leaded											
AGR400	5.9	5.3	4.8	4.1	4.0	3.5	3.2	2.8	2.5	1.9	—
AGR500	7.3	6.6	6.0	5.2	5.0	4.4	4.0	3.6	3.1	2.4	—
AGR600	8.8	8.0	7.2	6.2	6.0	5.2	4.8	4.2	3.8	2.8	—
AGR700	10.3	9.3	8.4	7.3	7.0	6.2	5.6	5.0	4.4	3.3	—
AGR800	11.7	10.7	9.6	8.3	8.0	6.9	6.4	5.6	5.1	3.7	—
AGR900	13.2	11.9	10.7	9.4	9.0	7.9	7.2	6.4	5.6	4.2	—
AGR1000	14.7	13.3	12.0	10.3	10.0	8.7	8.0	7.0	6.3	4.7	—
AGR1100	16.1	14.6	13.1	11.5	11.0	9.7	8.8	7.8	6.9	5.2	—
AGR1200	17.6	16.0	14.4	12.4	12.0	10.4	9.6	8.4	7.6	5.6	—
AGR1400	20.5	18.7	16.8	14.5	14.0	12.1	11.2	9.8	8.9	6.5	—
AHR (High Temperature) (AHRF for Pb-free version of product)											
16V—Leaded											
AHR450	6.1	5.6	5.1	4.6	4.5	4.0	3.6	3.3	3.0	2.5	1.1
AHR600	8.2	7.5	6.8	6.2	6.0	5.3	4.9	4.4	4.0	3.3	1.5
AHR650	8.8	8.1	7.4	6.7	6.5	5.7	5.3	4.8	4.3	3.6	1.6
AHR750	10.2	9.4	8.6	7.7	7.5	6.6	6.1	5.6	5.0	4.1	1.9
AHR1000	13.6	12.5	11.4	10.3	10.0	8.8	8.1	7.4	6.6	5.5	2.5
AHR1300	17.7	16.3	14.8	13.4	13.0	11.4	10.5	9.6	8.6	7.2	3.3
AHS (High Temperature)											
16V—Surface-mount											
AHS080-2018	1.20	1.04	0.90	0.80	0.77	0.68	0.62	0.60	0.53	0.46	0.26
AHS160	2.15	1.96	1.78	1.60	1.55	1.42	1.33	1.24	1.15	1.01	0.64
ASMD											
15-60V—Surface-mount											
ASMD030	0.35	0.31	0.27	0.23	0.22	0.19	0.17	0.15	0.13	0.11	—
ASMD050	0.59	0.53	0.46	0.39	0.37	0.33	0.29	0.26	0.23	0.18	—
ASMD075	0.91	0.81	0.71	0.60	0.58	0.50	0.45	0.40	0.35	0.28	—
ASMD100	1.37	1.22	1.06	0.90	0.86	0.76	0.68	0.60	0.52	0.41	—
ASMD125	1.58	1.40	1.23	1.04	1.00	0.87	0.78	0.70	0.60	0.48	—
ASMD150	1.93	1.70	1.50	1.27	1.22	1.07	0.95	0.85	0.74	0.58	—
ASMD200	2.63	2.34	2.04	1.73	1.66	1.45	1.30	1.16	1.00	0.80	—
ASMD250	3.00	2.66	2.32	1.97	1.89	1.65	1.48	1.32	1.14	0.91	—

Figures A1-A2. Thermal Derating Curves for Automotive Devices

A = AGR/AGRF

B = AHR/AHRF

Figure A1

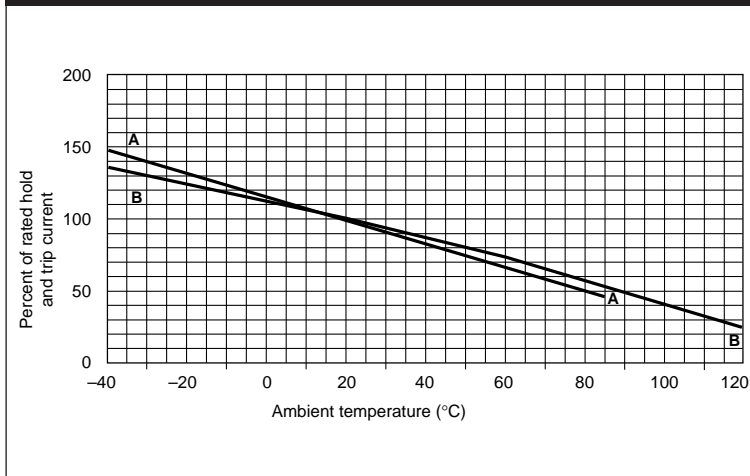

4

A = ASMD

B = AHS

Figure A2

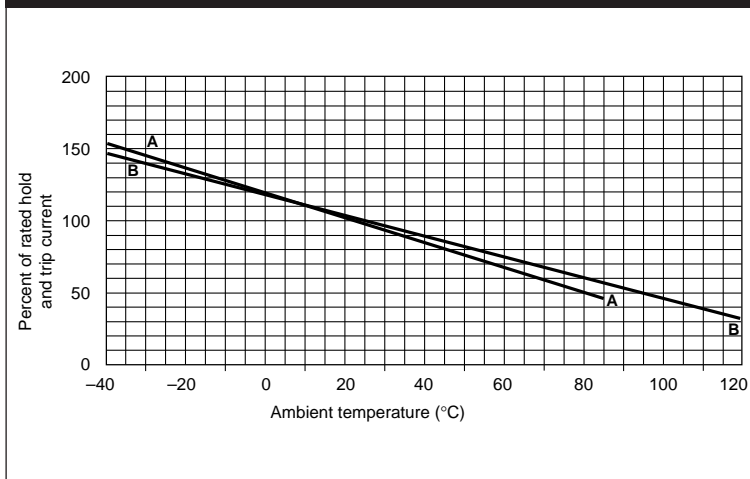

Table A3. Electrical Characteristics for Automotive Devices

Part Number	I_H (A) @	I_H (A) @	I_T (A)	V_{MAX} (V_{DC})	I_{MAX} (A)	$P_{D TYP}$ (W)	Max. Time-to-trip		R_{MIN} (Ω)	R_{1MAX} (Ω)	R_{2MAX} (Ω)	Figures for Dimensions
	R_{1MAX}	R_{2MAX}					(A)	(s)				
AGR (AGRF for Pb-free version of product)												
16V-Leaded												
AGR400	4.0	3.0	7.6	16	100	2.5	20	2.0	0.0186	0.061	0.085	A3, A6, A7
AGR500	5.0	4.3	9.4	16	100	2.7	25	2.5	0.0140	0.034	0.048	A3, A6, A7
AGR600	6.0	5.3	10.7	16	100	2.8	30	3.5	0.0095	0.028	0.032	A3, A6, A7
AGR700	7.0	6.5	13.2	16	100	3.0	35	4.0	0.0066	0.020	0.022	A3, A6, A7
AGR800	8.0	7.6	15.0	16	100	3.2	40	5.5	0.0049	0.0175	0.0181	A3, A6, A7
AGR900	9.0	8.6	16.5	16	100	3.4	45	6.0	0.0041	0.0135	0.0140	A3, A6, A7
AGR1000	10.0	9.6	18.5	16	100	3.6	50	7.0	0.0034	0.0102	0.0106	A3, A6, A7
AGR1100	11.0	10.5	20.3	16	100	3.7	55	7.5	0.0033	0.0089	0.0093	A3, A6, A7
AGR1200	12.0	11.5	22.1	16	100	4.2	60	8.0	0.0030	0.0086	0.0091	A3, A6, A7
AGR1400	14.0	13.0	27.3	16	100	4.6	70	9.0	0.0022	0.0064	0.0067	A3, A6, A7
AHR (AHRF for Pb-free version of product)												
16V-Leaded (High Temperature)												
AHR450	4.5	4.5	8.7	16	100	3.6	22.5	4.0	0.0170	0.054	0.054	A3, A6, A7
AHR600	6.0	6.0	12.0	16	100	4.1	30.0	6.5	0.0100	0.032	0.032	A3, A6, A7
AHR650	6.5	6.5	13.7	16	100	4.3	32.5	7.0	0.0090	0.026	0.026	A3, A6, A7
AHR750	7.5	7.5	14.8	16	100	4.5	37.5	8.0	0.0074	0.022	0.022	A3, A6, A7
AHR1000	10.0	10.0	20.5	16	100	5.3	50	10.5	0.0051	0.015	0.015	A3, A6, A7
AHR1300	13.0	13.0	27.0	16	100	6.9	65	15.0	0.0034	0.010	0.010	A3, A6, A7
AHS												
16V-Surface-mount (High Temperature)												
AHS080-2018	0.80	0.80	2.00	16	70	1.5	8.0	9.0	0.130	0.550	0.550	A4
AHS160	1.60	1.60	3.20	16	70	2.1	8.0	15.0	0.050	0.150	0.150	A5
ASMD												
15-60V-Surface-mount												
ASMD030	0.23	0.23	0.59	60	10	1.1	1.15	12.0	0.98	4.800	4.800	A5
ASMD050	0.39	0.39	0.98	60	10	1.1	1.95	20.0	0.29	1.400	1.400	A5
ASMD075	0.60	0.60	1.48	30	40	1.1	3.00	20.0	0.29	1.000	1.000	A5
ASMD100	0.90	0.90	2.16	30	40	1.1	4.50	20.0	0.098	0.480	0.480	A5
ASMD125	1.04	1.04	2.46	15	40	1.1	5.20	20.0	0.057	0.250	0.250	A5
ASMD150	1.27	1.27	2.95	15	40	1.2	6.35	25.0	0.049	0.250	0.250	A5
ASDM200	1.73	1.73	3.93	15	40	1.2	8.65	30.0	0.05	0.120	0.120	A5
ASMD250	1.97	1.97	5.00	15	40	1.2	9.85	30.0	0.035	0.085	0.085	A5

Notes:

I_H = Hold current: maximum current device will pass without interruption in 25°C unless otherwise specified (20°C for ASMD).

I_T = Trip current: minimum current that will switch the device from low resistance to high resistance in 25°C still air unless otherwise specified.

V_{MAX} = Maximum voltage device can withstand without damage at rated current.

I_{MAX} = Maximum fault current device can withstand without damage at rated voltage.

P_D = Power dissipated from device when in the tripped state in 25°C still air unless otherwise specified.

R_{1MAX} = Maximum resistance of device when measured one hour post reflow (surface-mount device) or one hour post trip (radial leaded device) at 25°C unless otherwise specified.

R_{2MIN} = Minimum functional resistance of device after being subjected to the stresses described in PS400 at 25°C unless otherwise specified.

R_{2MAX} = Maximum functional resistance of device after being subjected to the stresses described in PS400 at 25°C unless otherwise specified.

R_{MIN} = Minimum resistance of device as supplied at 25°C unless otherwise specified.

Figures A3–A7. Physical Description for Dimensions for Automotive Devices

Figure A3

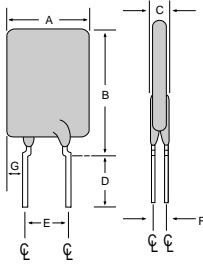

Figure A4

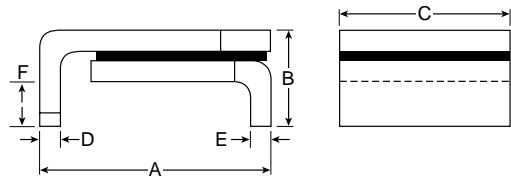

Figure A5

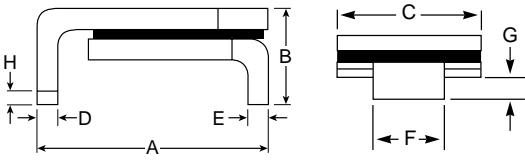

Figure A6

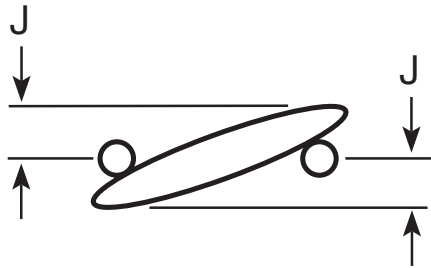
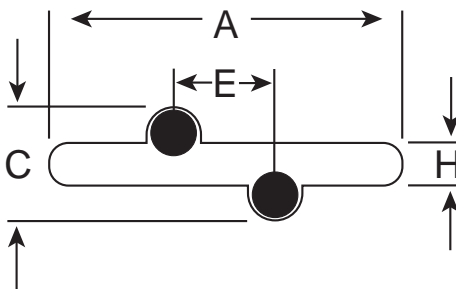

Figure A7



4

Table A4. Dimensions for Automotive Devices in Millimeters (Inches)

Part Number	Dimension												Figures						
	A		B		C		D		E		F			G		H		J	
	Min.	Max.	Min.	Max.	Min.	Max.	Min.	Max.	Min.	Max.	Typ.	Max.		Min.	Max.	Typ.	Max.	Typ.	Max.
AGR (AGRF for Pb-free version of product)																			
16V—Leaded																			
AGR400	—	8.9 (0.35)	—	14.1 (0.56)	—	3.0 (0.12)	7.6 (0.3)	—	4.3 (0.17)	5.8 (0.23)	1.2 (0.15)	—	—	3.05 (0.120)	1.24 (0.049)	1.4 (0.06)	A3, A6, A7		
AGR500	—	10.4 (0.41)	—	15.6 (0.61)	—	3.0 (0.12)	7.6 (0.3)	—	4.3 (0.17)	5.8 (0.23)	1.2 (0.05)	—	—	3.94 (0.155)	1.24 (0.049)	1.6 (0.06)	A3, A6, A7		
AGR600	—	10.7 (0.42)	—	18.4 (0.73)	—	3.0 (0.12)	7.6 (0.3)	—	4.3 (0.17)	5.8 (0.23)	1.2 (0.05)	—	—	4.07 (0.160)	1.24 (0.049)	1.6 (0.06)	A3, A6, A7		
AGR700	—	11.2 (0.44)	—	21.0 (0.73)	—	3.0 (0.12)	7.6 (0.3)	—	4.3 (0.17)	5.8 (0.23)	1.2 (0.05)	—	—	4.49 (0.177)	1.24 (0.049)	1.7 (0.07)	A3, A6, A7		
AGR800	—	12.7 (0.50)	—	22.2 (0.88)	—	3.0 (0.12)	7.6 (0.3)	—	4.3 (0.17)	5.8 (0.23)	1.2 (0.05)	—	—	5.08 (0.200)	1.24 (0.049)	1.8 (0.07)	A3, A6, A7		
AGR900	—	14.0 (0.55)	—	23.0 (0.91)	—	3.0 (0.12)	7.6 (0.3)	—	4.3 (0.17)	5.8 (0.23)	1.2 (0.05)	—	—	5.69 (0.224)	1.24 (0.049)	2.0 (0.08)	A3, A6, A7		
AGR1000	—	16.51 (0.65)	—	25.7 (1.01)	—	3.0 (0.12)	7.6 (0.3)	—	4.3 (0.17)	5.8 (0.23)	1.2 (0.05)	—	—	6.96 (0.274)	1.24 (0.049)	2.0 (0.08)	A3, A6, A7		
AGR1100	—	17.5 (0.69)	—	26.5 (1.04)	—	3.0 (0.12)	7.6 (0.3)	—	4.3 (0.17)	5.8 (0.23)	1.2 (0.05)	—	—	7.47 (0.294)	1.24 (0.049)	2.4 (0.09)	A3, A6, A7		
AGR1200	—	17.5 (0.69)	—	28.8 (1.14)	—	3.5 (0.14)	7.6 (0.3)	—	9.4 (0.37)	10.9 (0.43)	1.4 (0.06)	—	—	4.83 (0.190)	1.45 (0.057)	1.5 (0.06)	A3, A6, A7		
AGR1400	—	23.5 (0.925)	—	28.7 (1.13)	—	3.5 (0.14)	7.6 (0.3)	—	9.4 (0.37)	10.9 (0.43)	1.4 (0.06)	—	—	7.82 (0.308)	1.45 (0.057)	1.9 (0.07)	A3, A6, A7		
AHR (High Temperature) (AHRF for Pb-free version of product)																			
16V—Leaded																			
AHR450	—	10.4 (0.41)	—	15.6 (0.61)	—	3.0 (0.12)	7.6 (0.30)	—	4.3 (0.17)	5.8 (0.23)	1.2 (0.05)	—	—	3.94 (0.155)	1.24 (0.049)	1.6 (0.06)	A3, A6, A7		
AHR600	—	11.2 (0.44)	—	21.0 (0.73)	—	3.0 (0.12)	7.6 (0.30)	—	4.3 (0.17)	5.8 (0.23)	1.2 (0.05)	—	—	4.49 (0.177)	1.24 (0.049)	1.7 (0.067)	A3, A6, A7		
AHR650	—	12.7 (0.50)	—	22.2 (0.88)	—	3.0 (0.12)	7.6 (0.30)	—	4.3 (0.17)	5.8 (0.23)	1.2 (0.05)	—	—	5.08 (0.200)	1.24 (0.049)	1.8 (0.07)	A3, A6, A7		
AHR750	—	14.0 (0.55)	—	23.5 (0.93)	—	3.0 (0.14)	7.6 (0.30)	—	4.3 (0.17)	5.8 (0.23)	1.2 (0.05)	—	—	5.69 (0.224)	1.24 (0.049)	2.0 (0.08)	A3, A6, A7		
AHR1000	—	17.5 (0.69)	—	26.5 (1.04)	—	3.0 (0.12)	7.6 (0.30)	—	9.4 (0.37)	10.9 (0.43)	1.2 (0.05)	—	—	7.47 (0.294)	1.24 (0.049)	1.5 (0.06)	A3, A6, A7		
AHR1300	—	23.5 (0.925)	—	28.7 (1.13)	—	3.5 (0.14)	7.6 (0.30)	—	9.4 (0.37)	10.9 (0.43)	1.4 (0.06)	—	—	7.82 (0.308)	1.45 (0.057)	1.9 (0.08)	A3, A6, A7		

Table A4. Dimensions for Automotive Devices in Millimeters (Inches) *continued*

Part Number	Dimension																Figures
	A		B		C		D		E		F		G		H		
	Min.	Max.	Min.	Max.	Min.	Max.	Min.	Max.	Min.	Max.	Min.	Max.	Min.	Max.	Min.	Max.	
AHS (High Temperature)																	
16V—Surface-mount																	
AHS080-2018	4.72 (0.186)	5.44 (0.214)	—	1.52 (0.060)	4.22 (0.166)	4.93 (0.194)	0.25 (0.010)	0.36 (0.014)	0.25 (0.010)	0.36 (0.014)	0.30 (0.012)	0.46 (0.018)	—	—	—	—	A4
AHS160	8.00 (0.315)	9.40 (0.370)	—	3.00 (0.118)	6.0 (0.24)	6.71 (0.264)	0.56 (0.022)	0.71 (0.028)	0.56 (0.022)	0.71 (0.028)	3.68 (0.145)	3.94 (0.155)	0.66 (0.026)	1.37 (0.054)	0.43 (0.017)	—	A5
ASMD																	
15-60V—Surface-mount																	
ASMD030	6.73 (0.265)	7.98 (0.314)	—	3.18 (0.125)	4.8 (0.19)	5.44 (0.214)	0.56 (0.022)	0.71 (0.028)	0.56 (0.022)	0.71 (0.028)	2.16 (0.085)	2.41 (0.095)	0.66 (0.026)	1.37 (0.054)	0.43 (0.017)	—	A5
ASMD050	6.73 (0.265)	7.98 (0.314)	—	3.18 (0.125)	4.8 (0.19)	5.44 (0.214)	0.56 (0.022)	0.71 (0.028)	0.56 (0.022)	0.71 (0.028)	2.16 (0.085)	2.41 (0.095)	0.66 (0.026)	1.37 (0.054)	0.43 (0.017)	—	A5
ASMD075	6.73 (0.265)	7.98 (0.314)	—	3.18 (0.125)	4.8 (0.19)	5.44 (0.214)	0.56 (0.022)	0.71 (0.028)	0.56 (0.022)	0.71 (0.028)	2.16 (0.085)	2.41 (0.095)	0.66 (0.026)	1.37 (0.054)	0.43 (0.017)	—	A5
ASMD100	6.73 (0.265)	7.98 (0.314)	—	3.00 (0.118)	4.8 (0.19)	5.44 (0.214)	0.56 (0.022)	0.71 (0.028)	0.56 (0.022)	0.71 (0.028)	2.16 (0.085)	2.41 (0.095)	0.66 (0.026)	1.37 (0.054)	0.43 (0.017)	—	A5
ASMD125	6.73 (0.265)	7.98 (0.314)	—	3.00 (0.118)	4.8 (0.19)	5.44 (0.214)	0.56 (0.022)	0.71 (0.028)	0.56 (0.022)	0.71 (0.028)	2.16 (0.085)	2.41 (0.095)	0.66 (0.026)	1.37 (0.054)	0.43 (0.017)	—	A5
ASMD150	8.00 (0.315)	9.40 (0.370)	—	3.00 (0.118)	6.0 (0.24)	6.71 (0.264)	0.56 (0.022)	0.71 (0.028)	0.56 (0.022)	0.71 (0.028)	3.68 (0.145)	3.94 (0.155)	0.66 (0.026)	1.37 (0.054)	0.43 (0.017)	—	A5
ASMD200	8.00 (0.315)	9.40 (0.370)	—	3.00 (0.118)	6.0 (0.24)	6.71 (0.264)	0.56 (0.022)	0.71 (0.028)	0.56 (0.022)	0.71 (0.028)	3.68 (0.145)	3.94 (0.155)	0.66 (0.026)	1.37 (0.054)	0.43 (0.017)	—	A5
ASMD250	8.00 (0.315)	9.40 (0.370)	—	3.00 (0.118)	6.0 (0.24)	6.71 (0.264)	0.56 (0.022)	0.71 (0.028)	0.56 (0.022)	0.71 (0.028)	3.68 (0.145)	3.94 (0.155)	0.66 (0.026)	1.37 (0.054)	0.43 (0.017)	—	A5

Figures A8–A11. Typical Time-to-trip at 25°C for Automotive Devices

AGR/AGRF

- A = AGR400
- B = AGR500
- C = AGR600
- D = AGR700
- E = AGR800
- F = AGR900
- G = AGR1000
- H = AGR1100
- I = AGR1200
- J = AGR1400

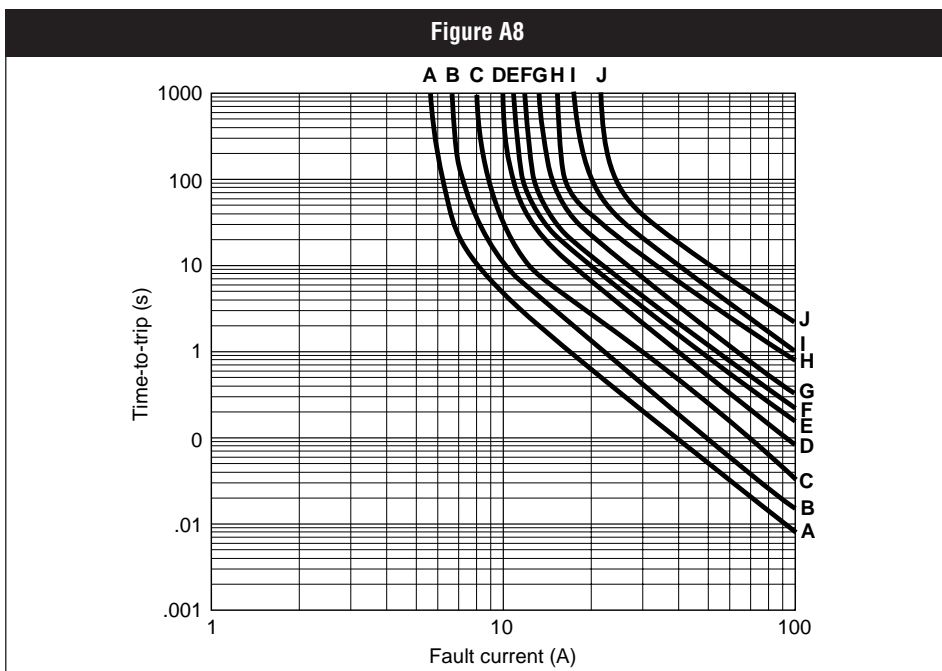

AHR/AHRF

- A = AHR450
- B = AHR600
- C = AHR650
- D = AHR750
- E = AHR1000
- F = AHR1300

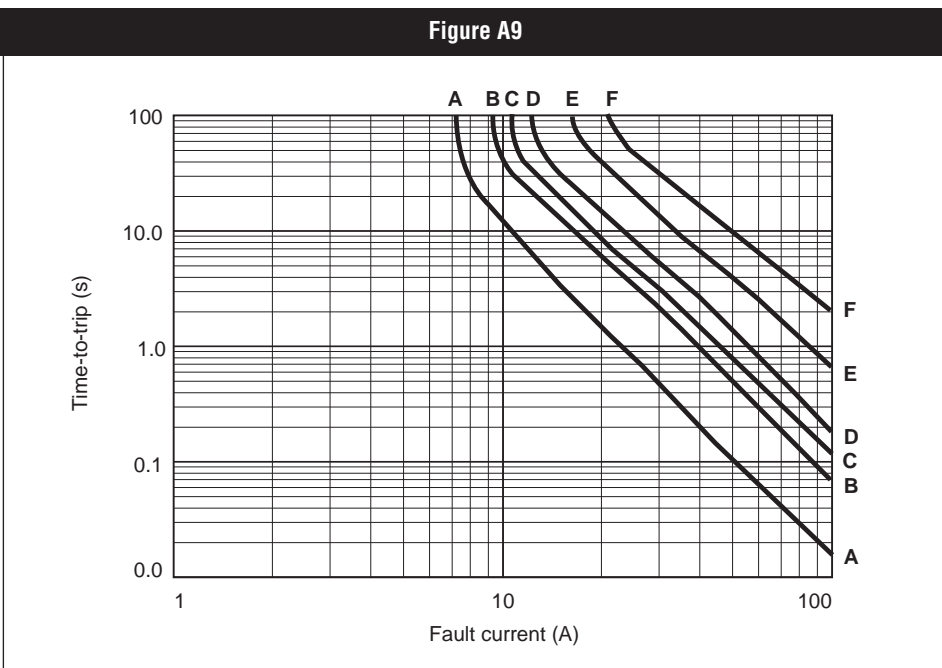

Figures A8–A11. Typical Time-to-trip at 25°C for Automotive Devices *continued*

AHS

A = AHS080-2018

B = AHS160

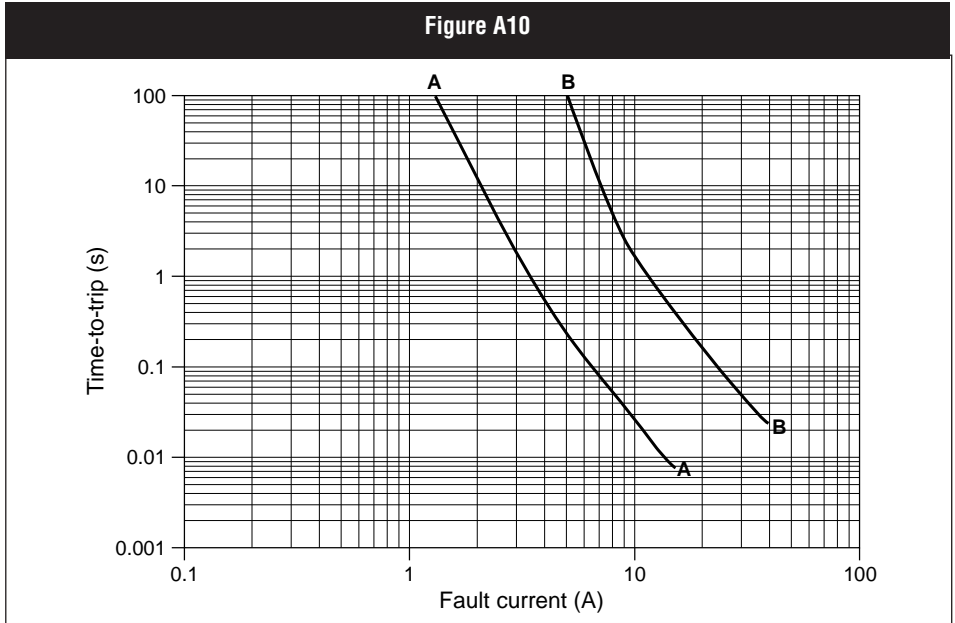

4

ASMD

A = ASMD030

B = ASMD050

C = ASMD075

D = ASMD100

E = ASMD125

F = ASMD150

G = ASMD200

H = ASMD250

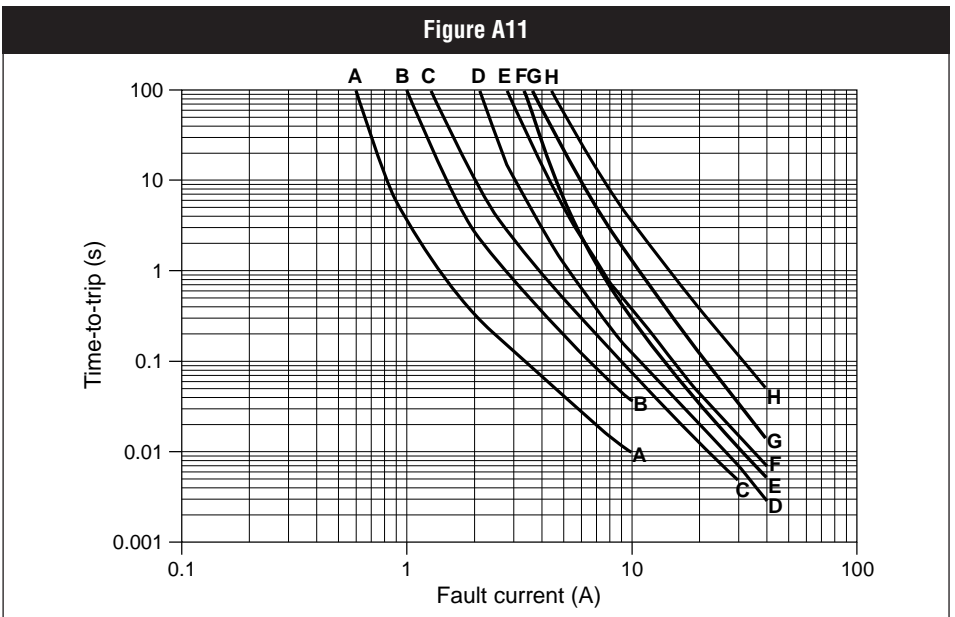

Table A5. Physical Characteristics and Environmental Specifications for Automotive Devices

AGR	
Physical characteristics	
Lead material	AGR400 to AGR1000: Tin/Lead Plated Copper, 0.52mm ² (20AWG) ϕ 0.8 mm/0.032in AGR1200 to AGR1400: Tin/Lead Plated Copper, 0.82mm ² (18AWG) ϕ 1.0mm/0.040in
Soldering characteristics	Solderability per ANSI/J-STD-002 Category 3
Solder heat withstand	AGR400: per IEC68-2-20 Test Tb, method 1a, condition a: can withstand 5 seconds at 260°C \pm 5°C AGR500-AGR1400: per IEC68-2-20 Test Tb, method 1a, condition b: can withstand 10 seconds at 260°C \pm 5°C
Insulating material	Cured, flame-retardant epoxy polymer; meets UL 94V-0
See PS400 for other physical characteristics	

*Devices are not designed to be placed through a reflow process.

AGRF	
Physical characteristics	
Lead material	AGRF400 to AGRF1000: Tin plated copper, 0.52mm ² (20AWG) ϕ 0.8 mm/0.032in AGRF1200 to AGRF1400: Tin plated copper, 0.82mm ² (18AWG) ϕ 1.0mm/0.040in
Soldering characteristics	Solderability per ANSI/J-STD-002 Category 3
Solder heat withstand	AGR400: per IEC68-2-20 Test Tb, method 1a, condition a: can withstand 5 seconds at 260°C \pm 5°C AGR500-AGR1400: per IEC68-2-20 Test Tb, method 1a, condition b: can withstand 10 seconds at 260°C \pm 5°C
Insulating material	Cured, flame-retardant epoxy polymer; meets UL 94V-0
See PS400 for other physical characteristics	

*Devices are not designed to be placed through a reflow process.

AGR/AGRF		
Environmental specifications		
Test	Conditions	Resistance Change
Passive aging	70°C, 1000 hours	\pm 5%
	85°C, 1000 hours	\pm 5%
Humidity aging	85°C, 85% RH, 1000 hours	\pm 5%
Thermal shock	85°C, -40°C (10 times)	\pm 5%
Solvent resistance	MIL-STD-202, Method 215F	No change
See PS400 for other environmental specifications		

AHR	
Physical characteristics	
Lead material	AHR450 to AHR1000: Tin/lead-plated Copper 0.52mm ² (20 AWG), ϕ 0.81mm/0.032in AHR1300: Tin lead-plated copper 0.82mm ² (18AWG), ϕ 1.0mm/0.04 in
Soldering characteristics	Solderability per ANSI/J-STD 002 Category 3
Solder heat withstand	per IEC 68-2-20, Test Tb, Method 1a, condition b; can withstand 10 seconds at 260°C \pm 5°C
Insulating material	Cured, flame-retardant epoxy polymer; meets UL 94V-0 requirements
See PS400 for other physical specifications	

*Devices are not designed to be placed through a reflow process.

AHRF	
Physical characteristics	
Lead material	AHR450 to AHR1000: Tin-plated Copper 0.52mm ² (20 AWG), ϕ 0.81mm/0.032in AHR1300: Tin-plated copper 0.82mm ² (18AWG), ϕ 1.0mm/0.04 in
Soldering characteristics	Solderability per ANSI/J-STD 002 Category 3
Solder heat withstand	per IEC 68-2-20, Test Tb, Method 1a, condition b; can withstand 10 seconds at 260°C \pm 5°C
Insulating material	Cured, flame-retardant epoxy polymer; meets UL 94V-0 requirements
See PS400 for other physical specifications	

*Devices are not designed to be placed through a reflow process.

Table A5. Physical Characteristics and Environmental Specifications for Automotive Devices *continued***AHR/AHRF****Environmental specifications**

Test	Conditions	Resistance Change
Passive aging	70°C, 1000 hours	±5%
	85°C, 1000 hours	±5%
Humidity aging	85°C, 85% RH, 1000 hours	±5%
Thermal shock	125°C, -40°C (10 times)	±5%
Solvent resistance	MIL-STD-202, Method 215F	No change
See PS400 for other environmental specifications		

ASMD**Physical characteristics**

Terminal pad material	98%+ Tin-plated Brass
Soldering characteristics	Solderability per ANSI-J-STD-002 Category 1
Solder heat withstand	per IEC-STD 68-2-20, Test Tb, Section 5, Method 1A
Flammability resistance	per IEC 695-2-2 Needle flame test for 20 seconds
Recommended storage conditions	40°C max, 70% RH max; devices may not meet specified ratings if storage conditions are exceeded
See PS400 for other physical characteristics	

Environmental specifications

Test	Conditions	Resistance Change
Passive aging	60°C, 1000 hours	±3% typical
	85°C, 1000 hours	±5% typical
Humidity aging	85°C, 85% RH, 100 hours	±1.2% typical
Thermal shock	85°C, -40°C (20 times)	-33% typical
	125°C, -55°C (10 times)	-33% typical
Solvent resistance	Freon	No change
	Trichloroethane	No change
	Hydrocarbons	No change
See PS400 for other environmental specifications		

AHS**Physical characteristics**

Lead material	Tin-plated brass to MIL-T-10727B
Soldering characteristics	Solderability per ANSI-J-STD-002 Category 1
Solder heat withstand	per IEC-STD 68-2-20, Test Tb, Section 5, Method 1A
Flammability	per IEC 695-2-2 Needle flame test for 20 seconds
See PS400 for other physical characteristics	

Environmental specifications

Test	Conditions	Resistance Change
Passive aging	70°C, 1000 hours	±3% Typical
	85°C, 1000 hours	±5% Typical
Humidity aging	85°C, 85% RH, 1000 hours	±1.2% Typical
Thermal shock	125°C, -40°C (20 times)	-33% Typical
Solvent resistance	Freon	No change
	Trichloroethane	No change
	Hydrocarbons	No change
See PS400 for other environmental specifications		

Table A6. Packaging and Marking Information for Radial-leaded Automotive Devices

Part Number	Bag Quantity	Tape & Reel Quantity	Ammo Pack Quantity	Standard Package Quantity	Part Marking	Agency Recognition
AGR Leaded						
AGR400	500	—	—	10,000	G4	*
AGR400-2	—	2,500	—	12,500	G4	*
AGR400-AP	—	—	2,000	10,000	G4	*
AGR500	500	—	—	10,000	G5	*
AGR500-2	—	2,000	—	10,000	G5	*
AGR500-AP	—	—	2,000	10,000	G5	*
AGR600	500	—	—	10,000	G6	*
AGR600-2	—	2,000	—	10,000	G6	*
AGR600-AP	—	—	2,000	10,000	G6	*
AGR700	500	—	—	10,000	G7	*
AGR700-2	—	1,500	—	7,500	G7	*
AGR700-AP	—	—	1,500	7,500	G7	*
AGR800	500	—	—	10,000	G8	*
AGR800-2	—	1,000	—	5,000	G8	*
AGR800-AP	—	—	1,000	5,000	G8	*
AGR900	500	—	—	10,000	G9	*
AGR900-2	—	1,000	—	5,000	G9	*
AGR900-AP	—	—	1,000	5,000	G9	*
AGR1000	250	—	—	5,000	G10	*
AGR1000-2	—	1,000	—	5,000	G10	*
AGR1000-AP	—	—	1,000	5,000	G10	*
AGR1100	250	—	—	5,000	G11	*
AGR1100-2	—	1,000	—	5,000	G11	*
AGR1100-AP	—	—	1,000	5,000	G11	*
AGR1200	250	—	—	5,000	G12	*
AGR1200-2	—	1,000	—	5,000	G12	*
AGR1200-AP	—	—	1,000	5,000	G12	*
AGR1400	250	—	—	5,000	G14	*
AGR1400-2	—	1,000	—	5,000	G14	*
AGR1400-AP	—	—	1,000	5,000	G14	*

*These devices have been designed for use in automotive applications. For commercial alternatives to these product series please see the Radial-leaded or Surface-mount section of this Databook.

Table A6. Packaging and Marking Information for Radial-leaded Automotive Devices *continued*

Part Number	Bag Quantity	Tape & Reel Quantity	Ammo Pack Quantity	Standard Package Quantity	Part Marking	Agency Recognition
AHR (High Temperature) Leaded						
AHR450	500	—	—	10,000	H4.5	*
AHR450-2	—	1,500	—	7,500	H4.5	*
AHR450-AP	—	—	1,500	7,500	H4.5	*
AHR600	500	—	—	10,000	H6	*
AHR600-2	—	1,500	—	7,500	H6	*
AHR600-AP	—	—	1,500	7,500	H6	*
AHR650	500	—	—	10,000	H6.5	*
AHR650-2	—	1,500	—	7,500	H6.5	*
AHR650-AP	—	—	1,500	7,500	H6.5	*
AHR750	500	—	—	10,000	H7.5	*
AHR750-2	—	1,000	—	5,000	H7.5	*
AHR750-AP	—	—	1,000	5,000	H7.5	*
AHR1000	250	—	—	5,000	H10	*
AHR1000-2	—	1,000	—	5,000	H10	*
AHR1000-AP	—	—	1,000	5,000	H10	*
AHR1300	250	—	—	5,000	H13	*
AHR1300-2	—	1,000	—	5,000	H13	*
AHR1300-AP	—	—	1,000	5,000	H13	*

Table A7. Packaging and Marking Information for Surface-mount Automotive Devices

Part Number	Tape & Reel Quantity	Standard Package Quantity	Part Marking	Recommended Pad Layouts [mm (in) See Figure A12]			Agency Recognition
				Dimension A (min*/nom)	Dimension B (nom)	Dimension C (nom)	
AHS (High Temperature)							
AHS080-2018	4,000	20,000	H08	4.6 (0.18)	1.5 (0.09)	3.4 (0.134)	*
AHS160	1,500	7,500	160	4.6 (0.18)	2.3 (0.09)	6.1 (0.240)	*
ASMD							
ASMD030	2,000	10,000	030	3.1 (0.12)	2.3 (0.09)	5.1 (0.201)	*
ASMD050	2,000	10,000	050	3.1 (0.12)	2.3 (0.09)	5.1 (0.201)	*
ASMD075	2,000	10,000	075	3.1 (0.12)	2.3 (0.09)	5.1 (0.201)	*
ASMD100	2,000	10,000	100	3.1 (0.12)	2.3 (0.09)	5.1 (0.201)	*
ASMD125	2,000	10,000	125	3.1 (0.12)	2.3 (0.09)	5.1 (0.201)	*
ASMD150	1,500	7,500	150	4.6 (0.18)	2.3 (0.09)	6.1 (0.240)	*
ASMD200	1,500	7,500	200	4.6 (0.18)	2.3 (0.09)	6.1 (0.240)	*
ASMD250	1,500	7,500	250	4.6 (0.18)	2.3 (0.09)	6.1 (0.240)	*

*These devices have been designed for use in automotive applications. For commercial alternatives to these product series please see the Radial-leaded or Surface-mount section of this Databook.

Figure A12. Recommended Pad Layout for Automotive Devices

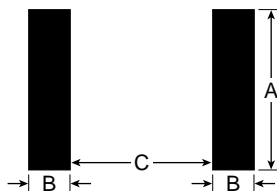

Part Numbering System for Automotive Devices

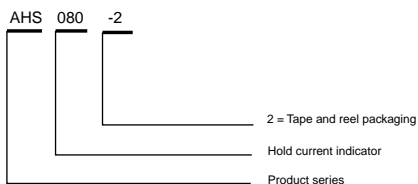
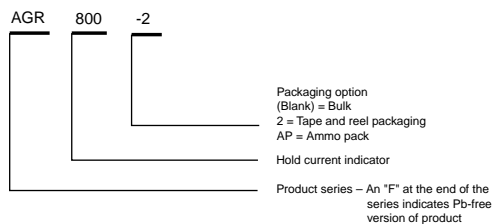

Part Marking System for Radial-leaded Automotive Devices

Side 1

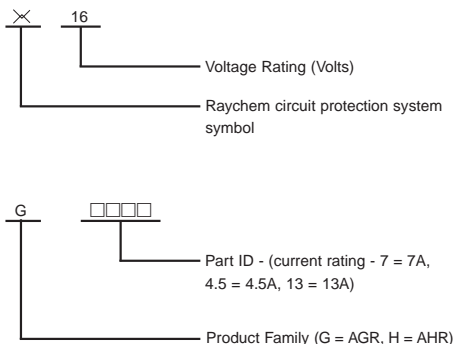

Side 2

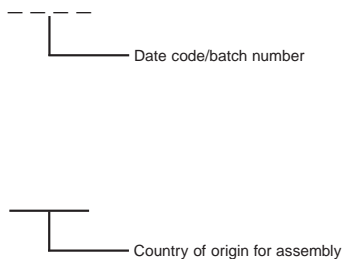

Part Marking System for Surface-mount Automotive Devices

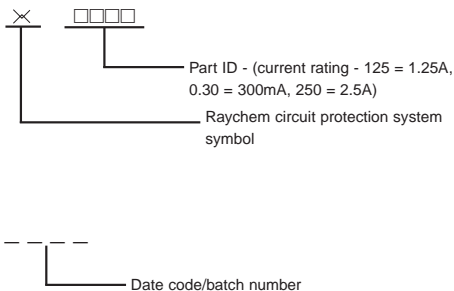

Table A8. Tape and Reel Specifications for Automotive Devices

AGR and AHR devices are available in tape and reel packaging per EIA468-B/IEC286-2 and EIA 481-2 standards. See Figures A13 and A14 for details.

Description	EIA Mark	Dimensions (mm)	Tolerance
Carrier tape width	W	18.0	-0.5/+1.0
Hold down tape width	W ₄	11.0	Minimum
Top distance between tape edges	W ₆	3.0	Maximum
Sprocket hole position	W ₅	9.0	-0.5/+0.75
Sprocket hole diameter	D ₀	4.0	±0.2
Abscissa to plane	H ₀	16.0	±0.5
Abscissa to top AGR500 to AGR600 & AHR450	H ₁	32.2	Maximum
Abscissa to top AGR700 to AGR1400 & AHR600 to AHR1300*	H ₁	45.0	Maximum
Overall width w/lead protrusion AGR400 to AGR600 & AHR450	C ₁	43.2	Maximum
Overall width w/lead protrusion AGR700 to AGR1400 & AHR600 to AHR1300	C ₁	55.0	Maximum
Overall width w/o lead protrusion AGR400 to AGR600 & AHR450	C ₂	42.5	Maximum
Overall width w/o lead protrusion AGR700 to AGR1400 & AHR600 to AHR1300	C ₂	54.0	Maximum
Lead protrusion	L ₁	1.0	Maximum
Protrusion of cut-out	L	11.0	Maximum
Protrusion beyond hold-down tape	I ₂	Not specified	—
Sprocket hole pitch	P ₀	12.7	±0.3
Device pitch AGR400 to AGR700, AHR450 to AHR600	—	12.7	±0.3
Device pitch AGR800 to AGR1400, AHR650 to AHR1300	—	25.4	±0.6
Pitch tolerance	—	20 consec.	±0.1
Tape thickness	t	0.9	Maximum
Overall tape and lead thickness AGR400 to AGR1100, AHR450 to AHR1000*	t ₁	2.0	Maximum
Overall tape and lead thickness AGR1200 to AGR1400, AHR1300*	t ₁	2.3	Maximum
Splice sprocket hole alignment	—	0	±0.3
Body lateral deviation	Dh	0	±1.0
Body tape plane deviation	Dp	0	±1.3
Ordinate to adjacent component lead AGR400 to AGR1100, AHR450 to AHR750	P1	3.81	±0.7
Ordinate to adjacent component lead AGR1200 to AGR1400, AHR1000 to AHR1300	P ₁	7.62	±0.7
Lead spacing AGR400 to AGR1100, AHR450 to AHR750*	F	5.08	±0.75/-0.5
Lead spacing AGR1200 to AGR1400, AHR1000 to AHR1300*	F	10.2	±0.75/-0.5
Reel width AGR400 to AGR600 & AHR450	w ₂	56.0	Maximum
Reel width AGR700 to AGR1400, AHR600 to AHR1300*	w ₂	63.5	Maximum
Reel diameter	a	370.0	Maximum
Space between flanges less device*	w ₁	4.75	±3.25
Arbor hold diameter	c	26.0	±12.0
Core diameter*	n	91.0	Maximum
Box	—	64/372/362	Maximum
Consecutive missing places	—	None	—
Empty places per reel	—	0.1%	Maximum

* Differs from EIA specification

Figure A13. EIA Referenced Taped Component Dimensions for AGR, AHR

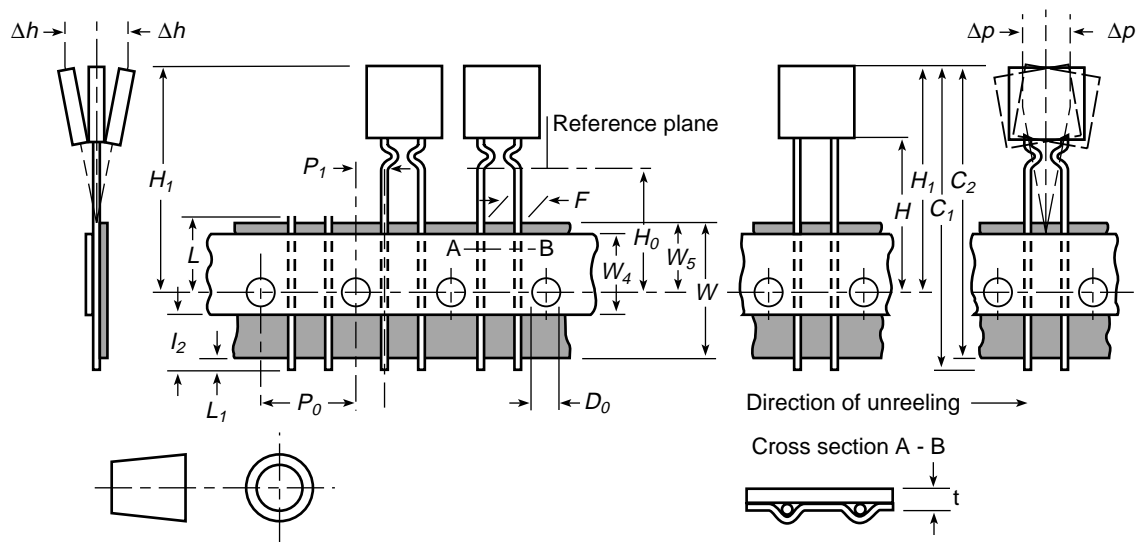
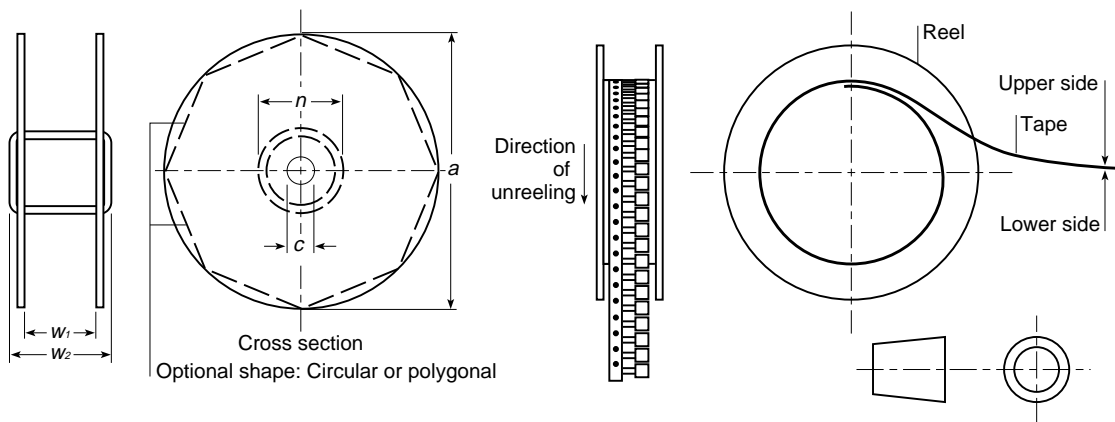

Figure A14. EIA Referenced Taped Component Dimensions for AHR, AGR



4

Table A8. Tape and Reel Specifications for Automotive Devices *continued*

AHS and ASMD devices are available in tape and reel packaging per EIA 468-2 standards. See Figures A15 and A16 for details.

Description	EIA Mark	Dimensions (mm)	Tolerance
Carrier tape width	W	16.0	± 0.3
Sprocket hole pitch	P ₀	4.0	± 0.10
Embossed cavity pitch (ASMD030 to ASMD125 & AHS080)	P ₁	8.0	± 0.10
Embossed cavity pitch (ASMD150 to ASMD250 & AHS160)	P ₁	12.0	± 0.10
Ordinate to embossed cavity center	P ₂	2.0	± 0.10
Embossed cavity length (inside) (AHS080)	A ₀	5.11	± 0.15
Embossed cavity length (inside) (ASMD030 to ASMD125 & AHS160)	A ₀	5.6	± 0.23
Embossed cavity length (inside) (ASMD150 to ASMD250)	A ₀	6.9	± 0.23
Embossed cavity width (inside) (AHS080)	B ₀	5.6	± 0.23
Embossed cavity width (inside) (ASMD030 to ASMD125)	B ₀	8.1	± 0.15
Embossed cavity width (inside) (ASMD150 to ASMD250)	B ₀	9.6	± 0.15
Embossed cavity length (outside)	B ₁ max.	12.1	—
Sprocket hole diameter	D ₀	1.5	+ 0.1, -0
Abscissa to embossed cavity center	F	7.5	± 0.10
Sprocket hole location	E ₁	1.75	± 0.10
Sprocket hole location (across embossed cavity)	E ₂ min.	14.25	—
Carrier tape thickness	T max.	0.6	—
Cover tape thickness	T ₁ max.	0.1	—
AHS080	K ₀	1.8	± 0.15
ASMD100, ASMD125	K ₀	3.2	± 0.15
ASMD150 to 250	K ₀	3.4	± 0.15
Embossed cavity depth (inside)	K ₀	—	± 0.15
Leader min.	—	400	—
Trailer min.	—	160	—
Reel diameter	A max.	609	—
Core diameter	N min.	50	—
Reel width measured at inside hub	W ₁	16.4	+ 2.0, -0
Reel width measured at outside hub	W ₂ max.	22.4	—

Figure A15. EIA Referenced Taped Component Dimensions for AHS and ASMD Devices

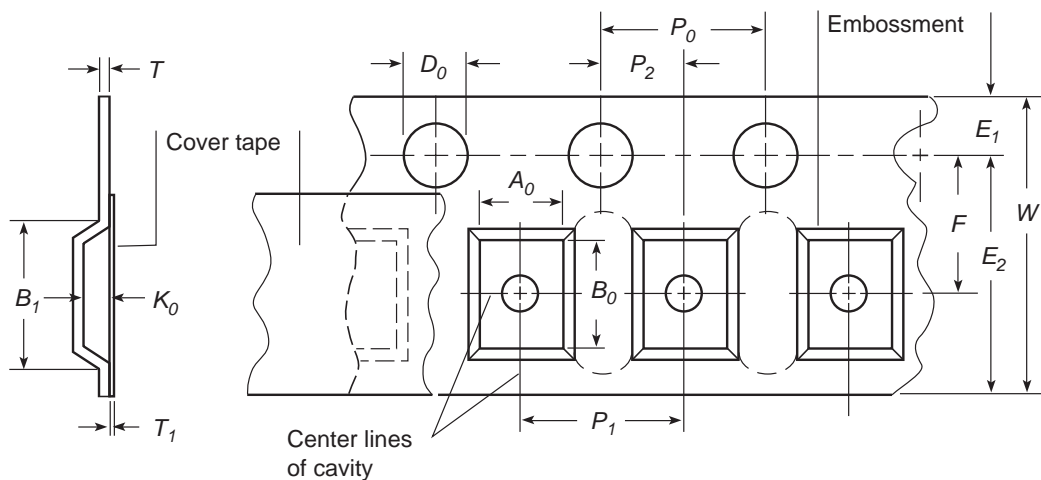

4

Figure A16. EIA Referenced Reel Dimensions for AHS and ASMD Devices

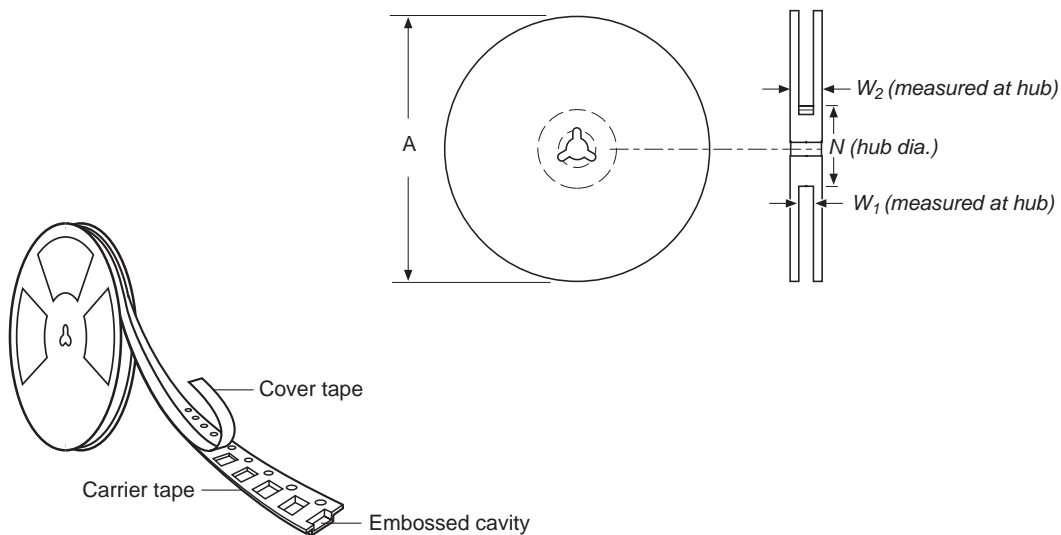

Latest Information

- Please visit us at www.circuitprotection.com or contact your local representative for the latest information.
- The information in this Databook contains some preliminary information. Raychem Circuit Protection, a division of Tyco Electronics reserves the right to change any of the specifications without notice. In addition, Tyco Electronics reserves the right to make changes—without notification to Buyer—to materials or processing that do not affect compliance with any applicable specification.



WARNING:

- Operation beyond the maximum ratings or improper use may result in device damage and possible electrical arcing and flame.
- The devices are intended for protection against occasional overcurrent or overtemperature fault conditions and should not be used when repeated fault conditions or prolonged trip events are anticipated.
- Contamination of the PPTC material with certain silicon based oils or some aggressive solvents can adversely impact the performance of the devices.
- Device performance can be impacted negatively if devices are handled in a manner inconsistent with recommended electronic, thermal, and mechanical procedures for electronic components.
- Operation in circuit with a large inductance can generate a circuit voltage ($L \frac{di}{dt}$) above the rated voltage of the PolySwitch resettable device.