



AH101

Medium Power, High Linearity Amplifier

The Communications Edge™

Advanced Product Information

Product Features

- 50-1500 MHz
- +45 dBm Output IP3
- 13 dB Gain
- +27 dBm P1dB
- MTBF >100 Years
- Unconditionally Stable
- Internally Matched
- Single Bias Supply (+7.0 to +9.0 V)



Actual Size

Product Description

The AH101 is a medium power gain block that offers excellent dynamic range in a low cost surface mount package. The combination of a single supply voltage and an unconditionally stable internally matched device, makes it ideal for both narrow band and broadband applications. Superior thermal design allows the product to achieve +45 dBm OIP3 performance at a mounting temperature of +85°C with an associated MTBF of >100 years³.

Functional Diagram

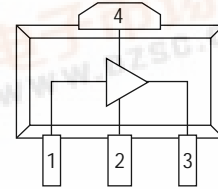

Function	Pin No.
Input	1
Ground	2
Output/Bias	3
Ground	4

Specifications

Parameter	Units	Min.	Typical	Max.
Frequency Range	MHz		50-1500	
S21 - Gain	dB	12	13.5	
S11 - Input Return Loss	dB		-20	
S22 - Output Return Loss	dB		-13	
Output IP3	dBm	+43	+47	
Output P1dB	dBm		+27	
Noise Figure	dB		5.0	
Operating Current Range	mA	170	200	230
Supply Voltage	V		9.0	

Test conditions unless otherwise noted.

1. T = 25°C, Vdd = 9.0 V, Frequency = 800 MHz, 50 ohm system.

2. OIP3 measured with two tones at an output power of 8 dBm/tone separated by 10 MHz. The suppression on the largest IM3 product is used to calculate the OIP3 using a 2:1 slope rule.

3. MTBF calculated with channel temperature at 155°C.

Recommended Maximum Ratings

Parameter	Rating
Operating Case Temperature	-40 to +85°C
Storage Temperature	-55 to +125°C
DC Voltage	+11 V
RF Input Power (continuous)	+18 dBm

Operation of this device above any of these parameters may cause permanent damage.

Typical Parameters

Parameter	Units	Typical	
Frequency	MHz	900	1500
S21	dB	13.5	12
S11	dB	-20	-12
S22	dB	-15	-12
Output IP3	dBm	+47	+46
Output P1dB	dBm	+27.0	+25.0
Noise Figure	dB	3.5	4.0

Typical parameters reflect performance in an application circuit.

Ordering Information

Part No.	Description
AH101	Medium Power High Linearity Amplifier (Available in tape and reel)
AH101-PCB	Fully Assembled Application Circuit



AH101

Advanced Product Information

Performance Charts (Vd = 9.0 V, Id = 200 mA, T = 25°C)

Gain vs. Frequency

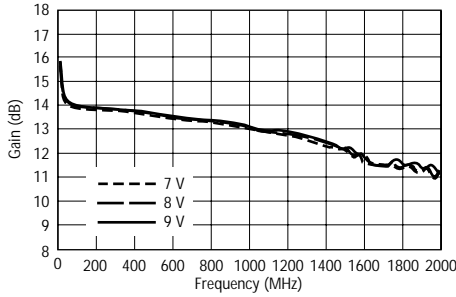

Return Loss vs. Frequency

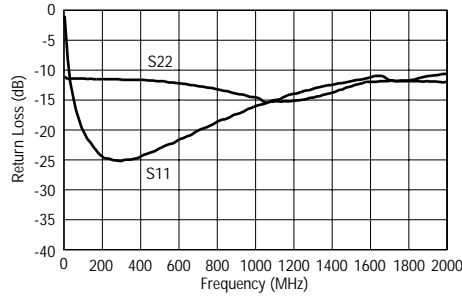

Noise Figure vs. Frequency

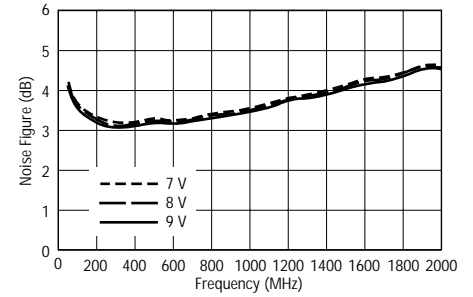

OIP3 vs. Frequency

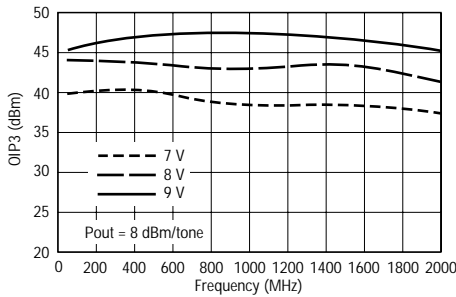

OIP3 vs. Pout

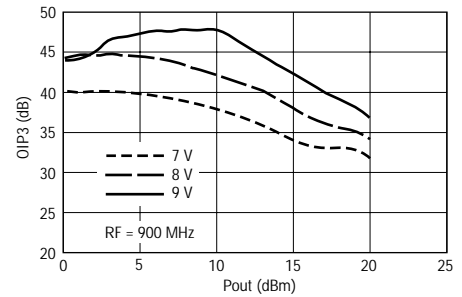

P1dB vs. Frequency

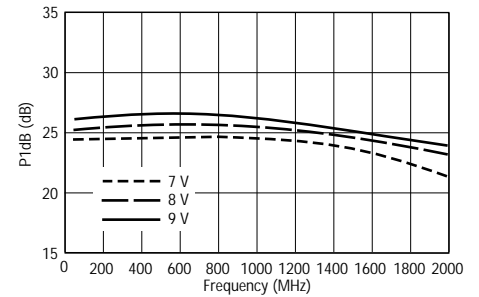

S21 vs. Frequency over Temperature

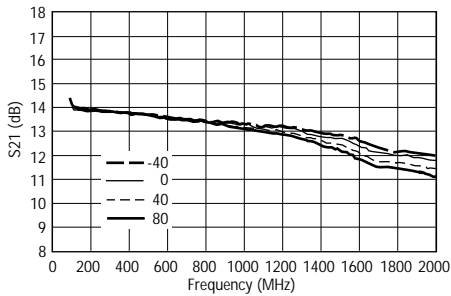

S11 vs. Frequency over Temperature

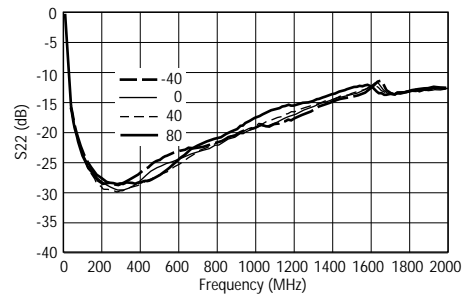

S22 vs. Frequency over Temperature

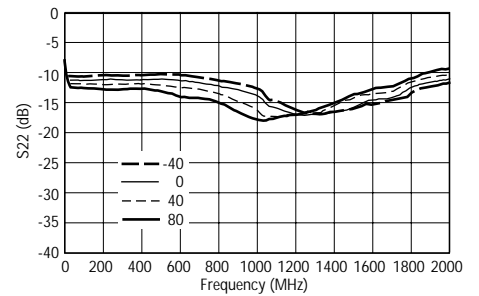

OIP3 vs. Temperature

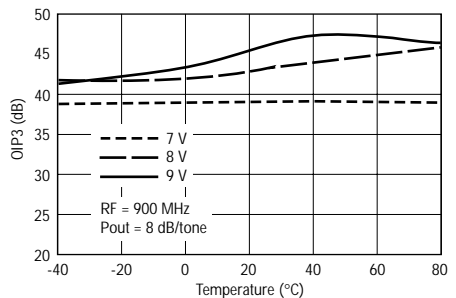

Gain vs. Pout

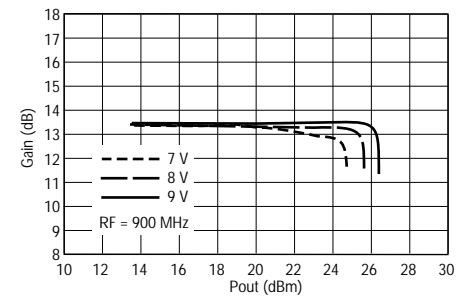

Application Circuit: 50ohm Evaluation Board

Typical Performance

Frequency	50 MHz	860 MHz	1500 MHz
Magnitude S21	14.0 dB	13.5 dB	12.0 dB
Magnitude S11	-12.0 dB	-20.0 dB	-12.0 dB
Magnitude S22	-12.0 dB	-15.0 dB	-12.0 dB
OIP3	45.0 dBm	47.0 dBm	46.0 dBm
Noise Figure	4.0 dB	3.5 dB	4.0 dB
Bias	Vd = 9 V, Id = 200 mA		

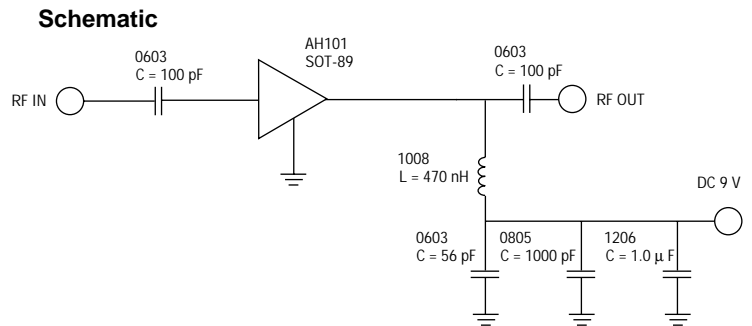

FR4 Board Layout (T = 14 Mil)

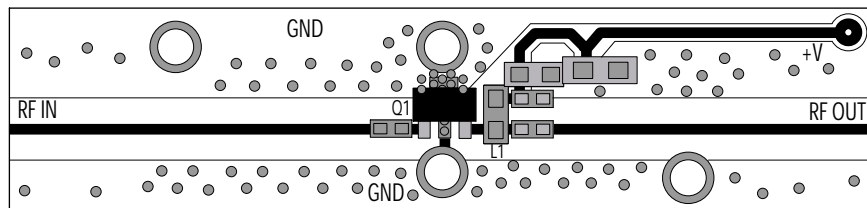

Thermal Specifications

Parameter	Rating
Operating Case Temperature	-40 to +85°C
Thermal Resistance (Maximum)	25°C/W
Junctions Temperature (Recommended Maximum)	+155°C

Notes:

1. Thermal Resistance determined at Maximum Tab Temperature and Maximum Power Dissipation.
2. Recommended Maximum Junction Temperature insures a MTBF of 1 million hours.
3. Refer to WJ Application Note "AH101 Temperature Effects on Reliability" for more information.

MTBF vs. Temperature

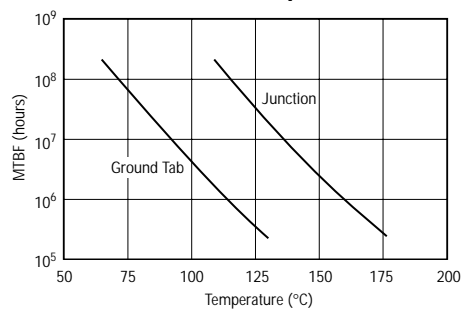

AH101

Advanced Product Information

Outline Drawing

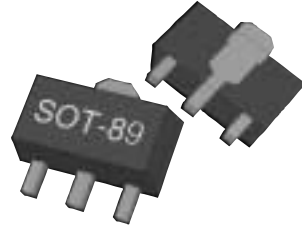
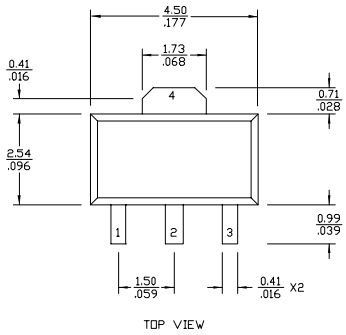

mm
inch

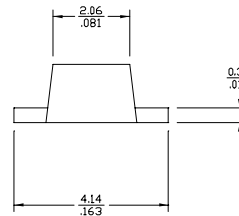
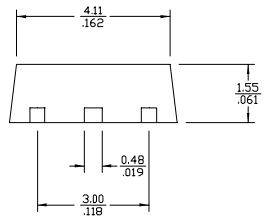

Land Pattern

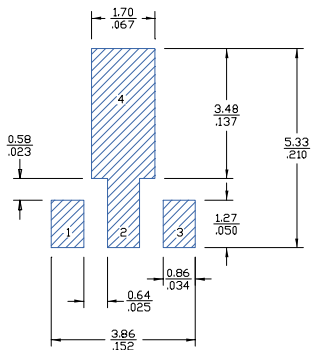

FUNCTION	PIN NO.
INPUT	1
GROUND	2
OUTPUT (BIAS)	3
GROUND	4

- Notes: 1. Ground vias are critical for thermal and RF grounding considerations.
 2. Two 2-56 screws with washers should be used for thermal grounding to the main chassis.
 3. Ground plane on the backside should extend past the holes for the 2-56 screws as a minimum.
 4. No soldermask should be applied to the backside where heat sink area contacts the main chassis.
 5. Holes for the 2-56 screws should be plated through.
 6. Keepout diameter for the 2-56 screw is to allow good thermal contact for the screw and washer.
 7. Trace width depends on PC board.
 8. A minimum of 1 oz. / 1 oz. copper should be used.

Mounting Configuration

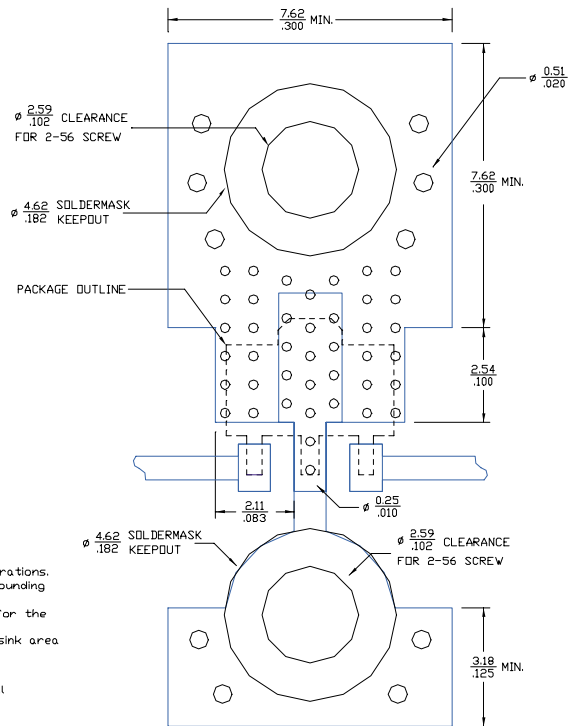

Typical Test Data

S-Parameters (V_{ds} = 9.0 V, I_{ds} = 200 mA, T = 25°C, unmatched device in a 50 ohm system)

Freq (MHz)	S11 (Mag)	S11 (Ang)	S21 (Mag)	S21 (Ang)	S12 (Mag)	S12 (Ang)	S22 (Mag)	S22 (Ang)
0.05	0.0959	-110.85	4.968	171.05	0.103	4.225	0.302	-170.06
0.10	0.0723	-112.91	4.955	170.61	0.102	0.790	0.297	-179.82
0.15	0.0703	-114.59	4.944	169.56	0.102	-1.529	0.298	174.82
0.20	0.0719	-115.94	4.916	168.02	0.103	-4.184	0.303	171.08
0.25	0.0719	-116.09	4.903	166.05	0.101	-5.445	0.260	161.00
0.30	0.0713	-117.70	4.895	163.86	0.101	-7.761	0.264	156.32
0.35	0.0725	-118.68	4.881	161.55	0.102	-8.193	0.268	152.73
0.40	0.0723	-119.46	4.858	159.30	0.103	-9.772	0.271	149.01
0.45	0.0758	-124.56	4.844	157.11	0.102	-11.460	0.273	145.78
0.50	0.0856	-125.91	4.826	154.77	0.099	-12.929	0.274	142.15
0.55	0.0972	-129.25	4.808	152.44	0.100	-14.689	0.275	138.78
0.60	0.1026	-129.83	4.785	150.13	0.102	-15.349	0.278	135.59
0.65	0.1141	-129.99	4.770	147.87	0.100	-15.673	0.279	132.17
0.70	0.1194	-130.49	4.748	145.62	0.100	-17.163	0.282	129.00
0.75	0.1274	-132.04	4.729	143.29	0.097	-19.586	0.282	126.06
0.80	0.1340	-134.79	4.710	141.08	0.097	-20.479	0.281	123.21
0.85	0.1403	-136.04	4.661	138.77	0.098	-20.997	0.280	120.33
0.90	0.1467	-138.98	4.649	136.55	0.094	-23.306	0.278	118.05
0.95	0.1550	-139.78	4.629	134.24	0.097	-23.698	0.277	114.72
1.00	0.1598	-143.31	4.612	132.01	0.095	-25.201	0.276	112.04
1.05	0.1733	-145.77	4.584	129.93	0.093	-26.567	0.271	109.60
1.10	0.1820	-145.80	4.556	127.42	0.093	-26.982	0.266	106.55
1.15	0.1950	-146.37	4.531	125.40	0.092	-29.315	0.262	104.05
1.20	0.2009	-148.27	4.514	123.25	0.093	-29.005	0.258	102.02
1.25	0.1931	-148.96	4.511	120.81	0.093	-31.669	0.239	99.07
1.30	0.2044	-148.12	4.485	118.58	0.091	-32.752	0.228	95.57
1.35	0.2107	-147.11	4.457	116.21	0.091	-33.430	0.219	90.80
1.40	0.2159	-146.41	4.429	113.99	0.089	-33.634	0.209	85.99
1.45	0.2232	-146.08	4.414	111.69	0.089	-36.007	0.198	80.96
1.50	0.2286	-145.80	4.380	109.44	0.090	-37.650	0.188	74.86
1.55	0.2417	-145.81	4.351	107.20	0.087	-37.629	0.179	69.19
1.60	0.2485	-144.28	4.321	104.96	0.086	-40.058	0.173	61.75
1.65	0.2565	-144.16	4.292	102.66	0.084	-39.799	0.165	54.63
1.70	0.2649	-144.02	4.258	100.33	0.083	-42.630	0.158	47.28
1.75	0.2753	-143.58	4.225	98.17	0.082	-43.869	0.154	37.81
1.80	0.2848	-143.91	4.189	95.91	0.082	-44.693	0.152	28.22
1.85	0.2921	-141.92	4.148	93.68	0.079	-45.864	0.154	19.31
1.90	0.2994	-141.30	4.112	91.50	0.080	-47.211	0.156	10.28
1.95	0.3036	-142.04	4.075	89.29	0.075	-48.646	0.162	1.73
2.00	0.3107	-141.08	4.034	87.00	0.076	-48.697	0.170	-6.35

