



GENERAL DESCRIPTION

The AK4103A is a digital audio transmitter (DIT) which supports data rate up to 192kHz sample rate operation. The AK4103A supports AES3, IEC60958, S/PDIF & EIAJ CP1201 interface standards. The AK4103A accepts audio data, auxiliary information data and etc, which is then biphase-encoded and driven on to a cable. The audio serial port supports eight formats.

FEATURES

- Sampling Rate up to 192kHz
- Support AES3, IEC60958, S/PDIF & EIAJ CP1201 professional and consumer formats
- Generates CRCC codes and parity bits
- On-chip RS422 line driver
- 16-byte on-chip buffer memory for Channel Status and User bits
- Supports synchronous/asynchronous access to Channel Status and User bits
- Supports multiple clock frequencies: 128fs, 256fs, 384fs and 512fs
- Supports Left/Right justified and I²S audio formats
- Easy to use 4 wire, Serial Host Interface
- Audio Routing Mode (Transparent Mode)
- Power supply: 4.75 to 5.25V
- TTL level I/F
- Small Package: 24pin VSOP
- Temperature range of - 40 to 85 °C



■ Block Diagram

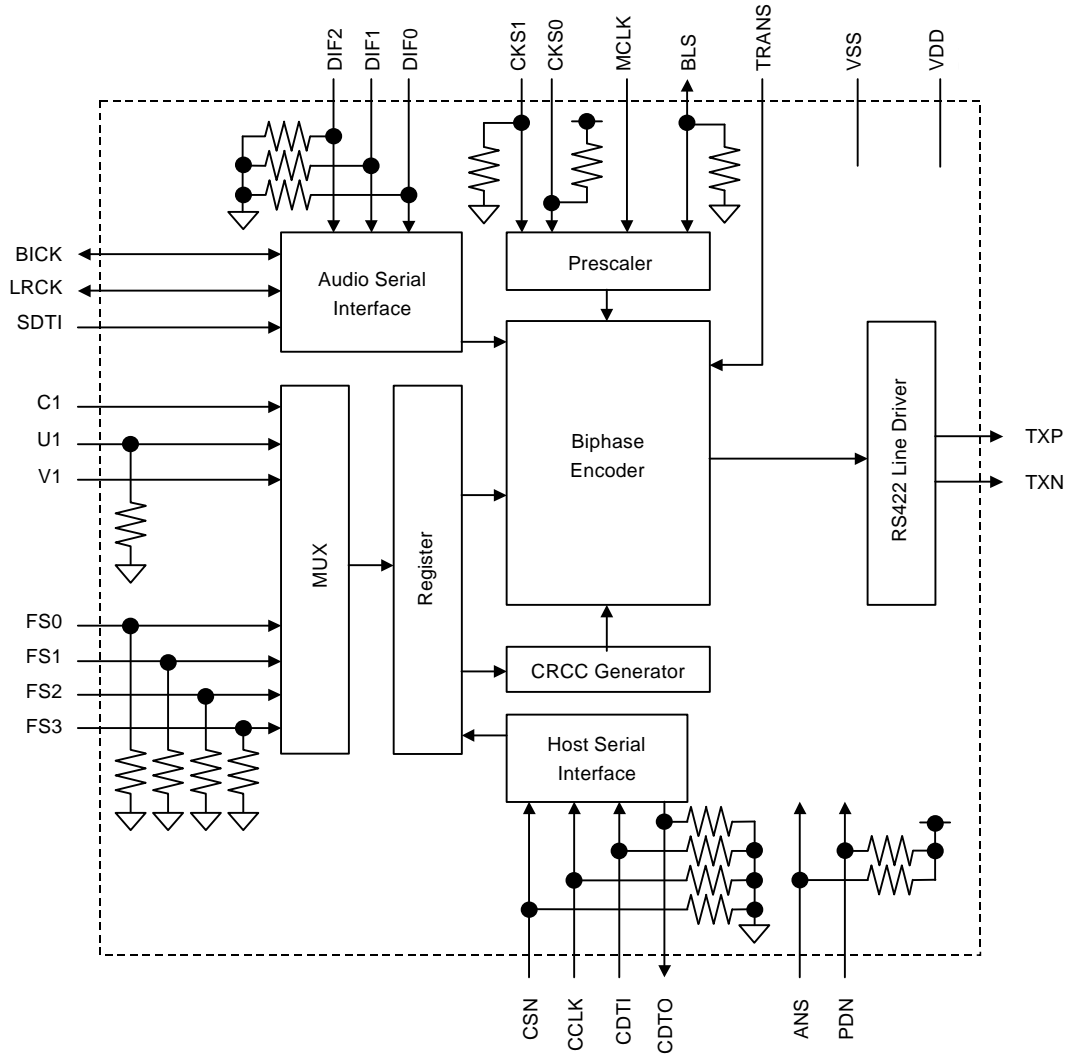

■ Ordering Guide

AK4103AVF -40 ~ +85°C 24pin VSOP (0.65mm pitch)

■ Pin Layout

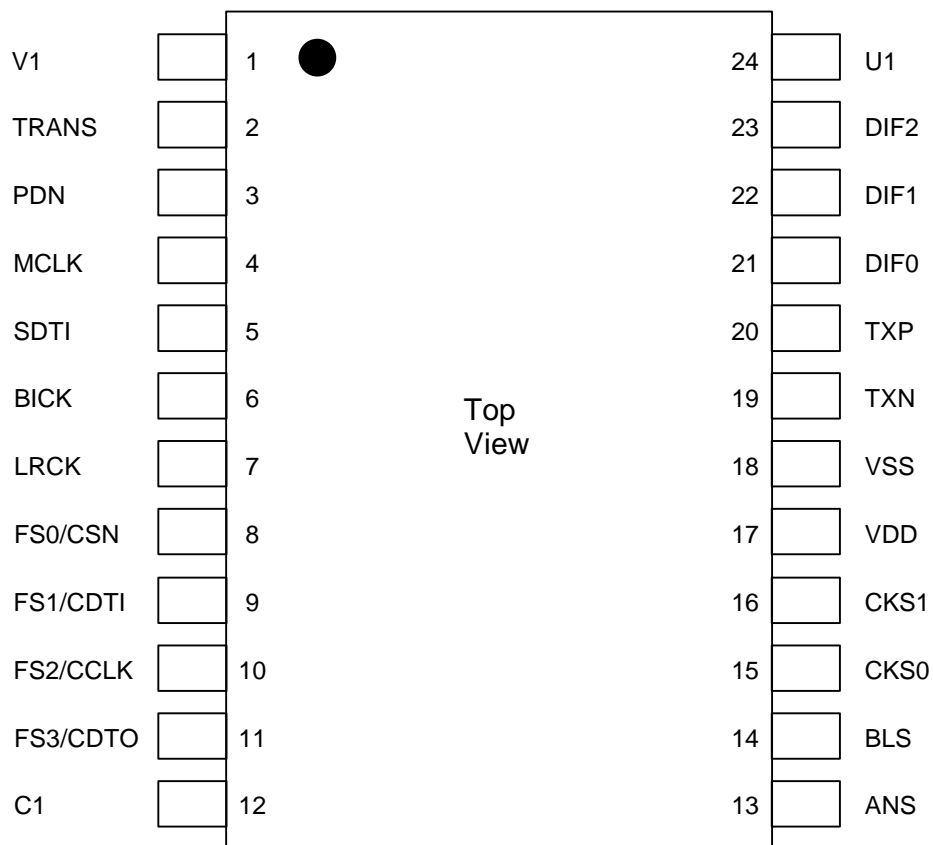

■ Comparison AK4103 with AK4103A

| Function | | AK4103 | AK4103A |
|-------------------------------|-------------------|------------|-------------------|
| Ambient Temperature | | -10 ~ 70°C | -40 ~ 85°C |
| CRCC generation by FS3-0 pins | Synchronous mode | X | O |
| CRCC generation by FS3-0 bits | Asynchronous mode | X | O |

O: Input data is reflected to CRCC.
 X: Input data is ignored for CRCC.

| PIN/FUNCTION | | | |
|--------------|----------|-----|---|
| No. | Pin Name | I/O | Description |
| 1 | V1 | I | Validity Bit Input Pin |
| 2 | TRANS | I | Audio Routing Mode (Transparent Mode) Pin at Synchronous mode 0: Normal mode, 1: Audio routing mode (transparent mode) |
| 3 | PDN | I | Power Down & Reset Pin (Pull-up Pin) When “L”, the AK4103A is powered-down, TXP/N pins are “L” and the control registers are reset to default values. |
| 4 | MCLK | I | Master Clock Input Pin |
| 5 | SDTI | I | Audio Serial Data Input Pin |
| 6 | BICK | I/O | Audio Serial Data Clock Input/Output Pin Serial Clock for SDTI pin which can be configured as an output based on the DIF2-0 inputs. |
| 7 | LRCK | I/O | Input/Output Channel Clock Pin Indicates left or right channel, and can be configured as an output based on the DIF2-0 inputs. |
| 8 | FS0 | I | Sampling Frequency Select 0 Pin at Synchronous mode (Pull-down Pin) |
| | CSN | I | Host Interface Chip Select Pin at Asynchronous mode (Pull-down Pin) |
| | AKMODE | I | AK4112B Mode Pin at Audio routing mode (Pull-down Pin) 0: Non-AKM receivers mode, 1: AK4112B mode |
| 9 | FS1 | I | Sampling Frequency Select 1 Pin at Synchronous mode (Pull-down Pin) |
| | CDTI | I | Host Interface Data Input Pin at Asynchronous mode (Pull-down Pin) |
| 10 | FS2 | I | Sampling Frequency Select 2 Pin at Synchronous mode (Pull-down Pin) |
| | CCLK | I | Host Interface Bit Clock Input Pin at Asynchronous mode (Pull-down Pin) |
| 11 | FS3 | I | Sampling Frequency Select 3 Pin at Synchronous mode (Pull-down Pin) |
| | CDTO | O | Host Interface Data Output Pin at Asynchronous mode (Pull-down Pin) |
| 12 | C1 | I | Channel Status Bit Input Pin |
| 13 | ANS | I | Asynchronous/Synchronous Mode Select Pin (Pull-up Pin) 0: Asynchronous mode, 1: Synchronous mode |
| 14 | BLS | I/O | Block Start Input/Output Pin (Pull-down Pin) In normal mode, the channel status block output is “H” for the first four bytes. In audio routing mode, the pin is configured as an input. When PDN pin = “L”, BLS pin goes “H” at Normal mode. |
| 15 | CKS0 | I | Clock Mode Select 0 Pin (Pull-up Pin) |
| 16 | CKS1 | I | Clock Mode Select 1 Pin (Pull-down Pin) |
| 17 | VDD | - | Power Supply Pin, 4.75V~5.25V |
| 18 | VSS | - | Ground Pin, 0V |
| 19 | TXN | O | Negative Differential Output Pin |
| 20 | TXP | O | Positive Differential Output Pin |
| 21 | DIF0 | I | Audio Serial Interface Select 0 Pin (Pull-down Pin) |
| 22 | DIF1 | I | Audio Serial Interface Select 1 Pin (Pull-down Pin) |
| 23 | DIF2 | I | Audio Serial Interface Select 2 Pin (Pull-down Pin) |
| 24 | U1 | I | User Data Bit Input Pin for Channel 1 (Pull-down Pin) |

Notes:

1. Internal pull-up and pull-down resistors are connected on-chip. The value of the resistors is 43kΩ (typ).
2. All input pins except internal pull-down/pull-up pins should not be left floating.

| |
|---------------------------------|
| ABSOLUTE MAXIMUM RATINGS |
|---------------------------------|

(VSS=0V; Note 3)

| Parameter | Symbol | min | max | Units |
|---|--------|------|---------|-------|
| Power Supply | VDD | -0.3 | 6.0 | V |
| Input Current (All pins except supply pins) | IIN | - | ±10 | mA |
| Input Voltage | VIND | -0.3 | VDD+0.3 | V |
| Ambient Operating Temperature | Ta | -40 | 85 | °C |
| Storage Temperature | Tstg | -65 | 150 | °C |

Notes:

- All voltages with respect to ground.

WARNING: Operation at or beyond these limits may result in permanent damage to the device.

Normal operation is not guaranteed at these extremes.

| |
|---|
| RECOMMENDED OPERATING CONDITIONS |
|---|

(VSS=0V; Note 1)

| Parameter | Symbol | min | typ | max | Units |
|--------------|--------|------|-----|------|-------|
| Power Supply | VDD | 4.75 | 5.0 | 5.25 | V |

*AKM assumes no responsibility for the usage beyond the conditions in this datasheet.

| |
|---------------------------|
| DC CHARACTERISTICS |
|---------------------------|

(Ta=25°C; VDD=4.75~5.25V)

| Parameter | Symbol | min | typ | max | Units |
|---|--------|---------|-----|-----|-------|
| Power Supply Current (fs=108kHz, Note 4) | IDD | | 6 | 15 | mA |
| High-Level Input Voltage | VIH | 2.4 | - | - | V |
| Low-Level Input Voltage | VIL | - | - | 0.8 | V |
| High-Level Output Voltage (Except TXP/N pins: Iout=-400μA) | VOH | VDD-1.0 | - | - | V |
| (TXP/N pins: Iout= -8mA) | VOH | VDD-0.8 | - | - | V |
| Low-Level Output Voltage (Except TXP/N pins: Iout= 400μA) | VOL | - | - | 0.4 | V |
| (TXP/N pins: Iout= 8mA) | VOL | - | - | 0.6 | V |
| Input Leakage Current | Iin | - | - | ±10 | μA |

Notes:

- Power supply current (IDD) is 3mA(typ)@fs=48kHz and 9mA(typ)@fs=192kHz.

IDD increases by 20mA(typ) with professional output driver circuit.

IDD is 350μA(typ) if PDN pin = "L", TRANS pin = "H" and all other input pins except internal pull-up/pull-down pins are held to VSS.

| |
|----------------------------------|
| SWITCHING CHARACTERISTICS |
|----------------------------------|

(Ta=25°C; VDD=4.75~5.25V; CL=20pF)

| Parameter | Symbol | min | typ | max | Units |
|--------------------------------------|--------|-------|------|--------|-------|
| Master Clock Timing | | | | | |
| Frequency | fCLK | 3.584 | | 27.648 | MHz |
| Duty Cycle | dCLK | 40 | | 60 | % |
| LRCK Timing | | | | | |
| Frequency | fs | 28 | | 192 | kHz |
| Duty Cycle at Slave Mode | dLCK | 45 | | 55 | % |
| Duty Cycle at Master Mode | | | 50 | | % |
| Audio Interface Timing | | | | | |
| Slave Mode | | | | | |
| BICK Period | tBCK | 36 | | | ns |
| BICK Pulse Width Low | tBCKL | 15 | | | ns |
| Pulse Width High | tBCKH | 15 | | | ns |
| LRCK Edge to BICK “↑” | tLRB | 15 | | | ns |
| BICK “↑” to LRCK Edge | tBLR | 15 | | | ns |
| SDTI Hold Time | tSDH | 8 | | | ns |
| SDTI Setup Time | tSDS | 8 | | | ns |
| Master Mode | | | | | |
| BICK Frequency | fBCK | | 64fs | | Hz |
| BICK Duty | dBCK | | 50 | | % |
| BICK “↓” to LRCK | tMBLR | -20 | | 20 | ns |
| SDTI Hold Time | tSDH | 20 | | | ns |
| SDTI Setup Time | tSDS | 20 | | | ns |
| Control Interface Timing | | | | | |
| CCLK Period | tCCK | 200 | | | ns |
| CCLK Pulse Width Low | tCCKL | 80 | | | ns |
| Pulse Width High | tCCKH | 80 | | | ns |
| CDTI Setup Time | tCDS | 50 | | | ns |
| CDTI Hold Time | tCDH | 50 | | | ns |
| CSN “H” Time | tCSW | 520 | | | ns |
| CSN “↓” to CCLK “↑” | tCSS | 50 | | | ns |
| CCLK “↑” to CSN “↑” | tCSH | 50 | | | ns |
| CDTO Delay | tDCD | | | 45 | ns |
| CSN “↑” to CDTO Hi-Z | tCCZ | | | 70 | ns |
| Power-down & Reset Timing | | | | | |
| PDN Pulse Width | tPDW | 150 | | | ns |

Notes:

5. BICK rising edge must not occur at the same time as LRCK edge.
6. CDTO pin is internally connected to a pull-down resistor.

■ Timing Diagram

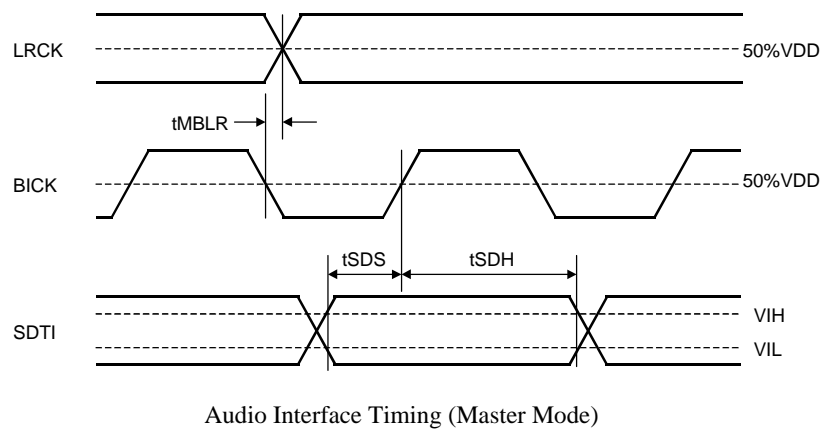
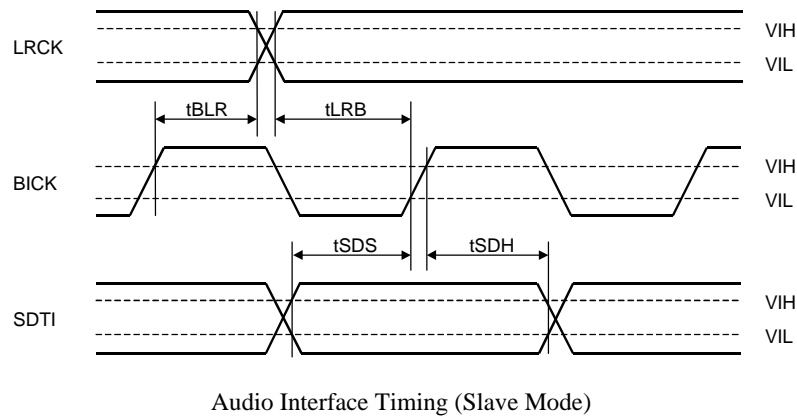
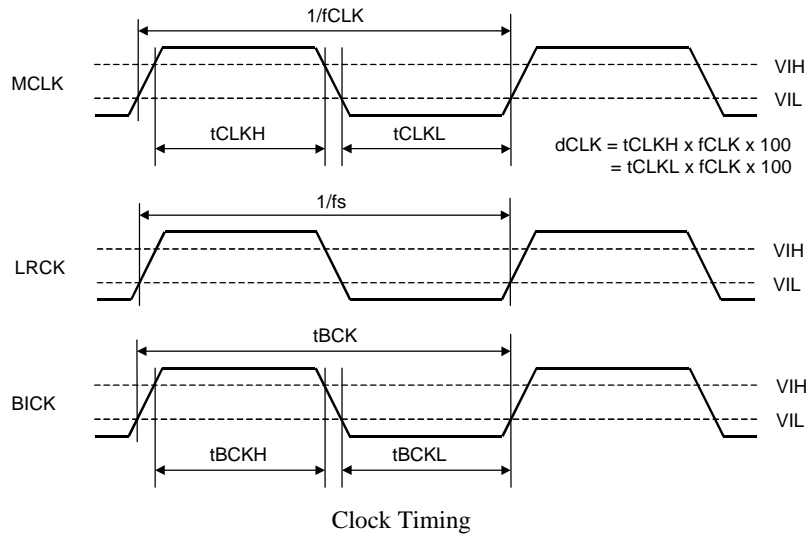

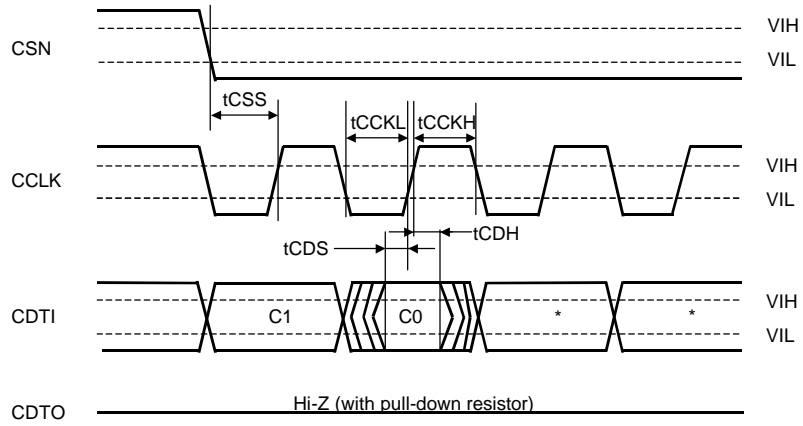

WRITE/READ Command Input Timing

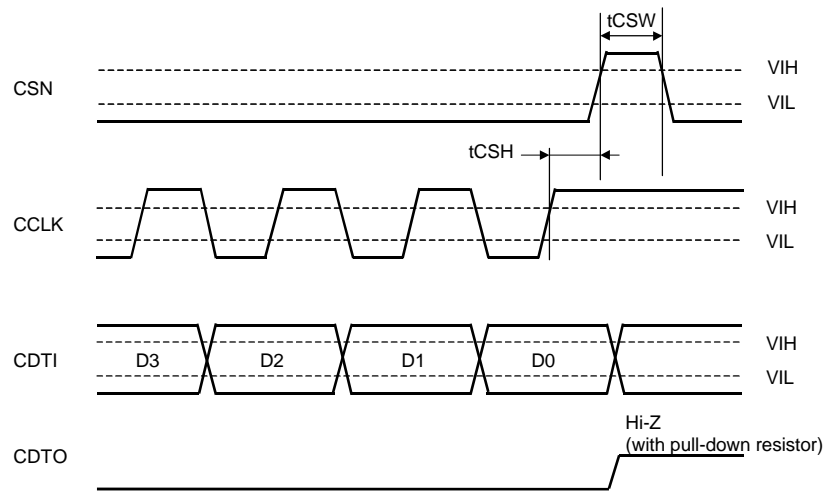

WRITE Data Input Timing

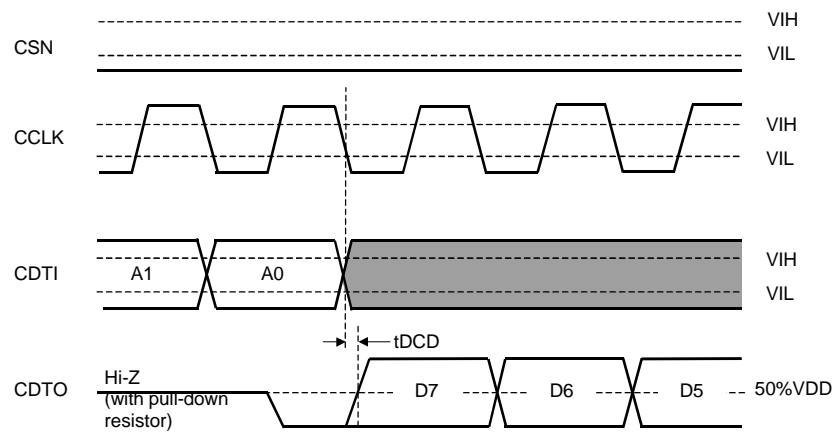

READ Data Output Timing 1

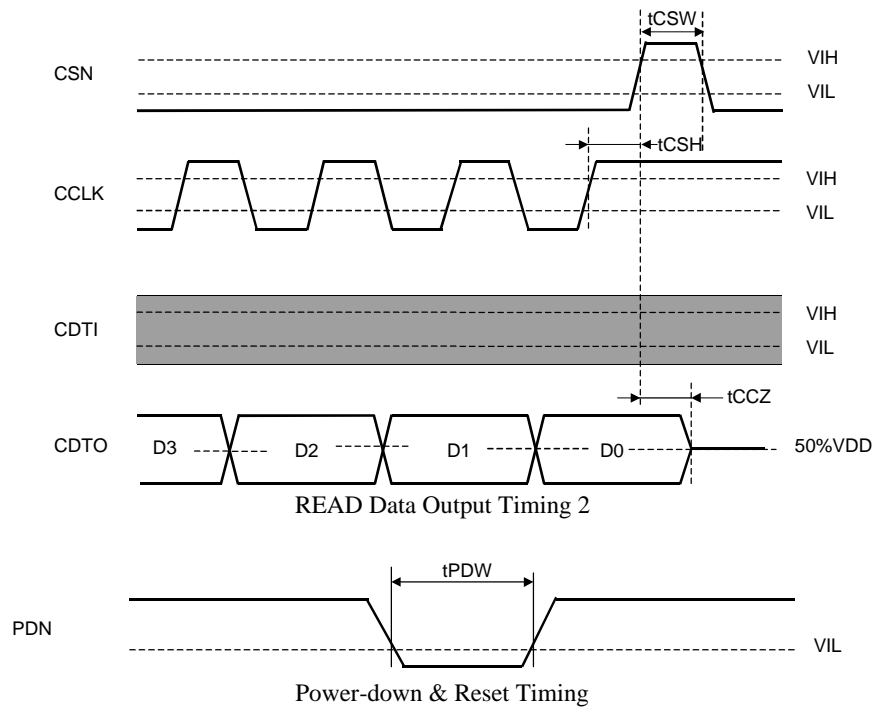

| |
|---------------------------|
| OPERATION OVERVIEW |
|---------------------------|

■ General Description

The AK4103A is a monolithic CMOS circuit that biphas-encodes and transmits audio data, auxiliary information data and etc according to the AES3, IEC60958, S/PDIF and EIAJ CP1201 interface standards. There is one set of stereo channels that can be transmitted simultaneously. The chip accepts audio data and auxiliary information data separately, biphas-mark encodes the data internally, and drives it directly or through a transformer to a transmission line. There are two modes of operation: asynchronous and synchronous. See section of “Asynchronous mode / Synchronous mode”.

■ Initialization

The AK4103A takes 8 bit clock cycles to initialize after PDN pin goes inactive. Also, for correct synchronization, MCLK should be synchronized with LRCK but the phase is not critical.

■ MCLK and LRCK Relationship

For correct synchronization, MCLK and LRCK should be derived from the same clock signal either directly (as through a frequency divider) or indirectly (for example, as through a DSP). The relationship of BICK to LRCK is fixed and should not change. If MCLK or LRCK move such that they are shifted (128fs x 3) or more MCLK cycles from their initial conditions, the chip will reset the internal frame and bit counters. However, control registers are not initialized. The following frequencies are supported for MCLK.

| CKS1 | CKS0 | MCLK | fs |
|------|------|-------|------------|
| 0 | 0 | 128fs | 28k-192kHz |
| 0 | 1 | 256fs | 28k-108kHz |
| 1 | 0 | 384fs | 28k-54kHz |
| 1 | 1 | 512fs | 28k-54kHz |

Table 1. MCLK Frequency

■ Asynchronous Mode/ Synchronous Mode

1. Asynchronous Mode (software controlled)

The AK4103A can be configured in the asynchronous mode by connecting the ANS pin to logic “L”. In this mode the 16 to 24-bit audio samples are accepted through a configured audio serial port, and the channel status and user data through a serial control host interface (SCI). The SCI allows access to internal buffer memory and control registers which are used to store the channel status and user data. 4bytes per channel of user and channel status is stored. This data is multiplexed with the audio data from the audio serial port, the parity bit is generated, and the bit stream is biphas-mark encoded and driven through the RS422 line driver. The CRCC code for the channel status is also generated according to the professional mode definition in the AES3 standards. This mode also allows for software control for mute, reset, audio format selection, clock frequency settings and output enables, via the serial host interface.

2. Synchronous Mode (hardware controlled)

The AK4103A when configured in synchronous mode accepts 16 - 24 bit audio samples through the audio serial port and provides dedicated pins for the control data and allows all channel status, user data and validity bits to be serially input through port pins. This data is multiplexed, the parity bit generated, and the bit stream is biphase-mark encoded and driven through an RS422 line driver.

2-1. Audio Routing Mode (Transparent Mode)

The AK4103A can be configured in audio routing mode (transparent mode) by ANS pin = TRANS pin = "1". In this mode, the channel status(C), user data(U) and validity(V) bits must pass through unaltered. The Block Start(B) signal is configured as an input, allowing the transmit block structure to be slaved to the block structure of the receiver. The C, U and V are now transmitted with the current audio sample. In audio routing mode, no CRCC bytes are generated and C bits pass through unaltered. In audio routing mode, the FS0/CSN pin changes definition to AKMODE pin. When set "H" the AK4103A can be configured directly with the AK4112B receiver. When set "L", it may be used with other non-AKM receivers. Setting the part with TRANS pin = "1" and ANS pin = "0" is illegal and places the chip into a test mode.

| Pin | | Modes | | Source for C, U and V bits |
|-----|-------|--------------------------|--------------------|---|
| ANS | TRANS | Synchronous/Asynchronous | Audio Routing | |
| 0 | 0 | Asynchronous mode | Normal mode | C Pin ORed Control Register U Pin ORed Control Register V Pin ORed Control Register |
| 0 | 1 | (Test mode) | | |
| 1 | 0 | Synchronous mode | Normal mode | C,U and V pin |
| 1 | 1 | | Audio routing mode | |

Table 2. Mode setting

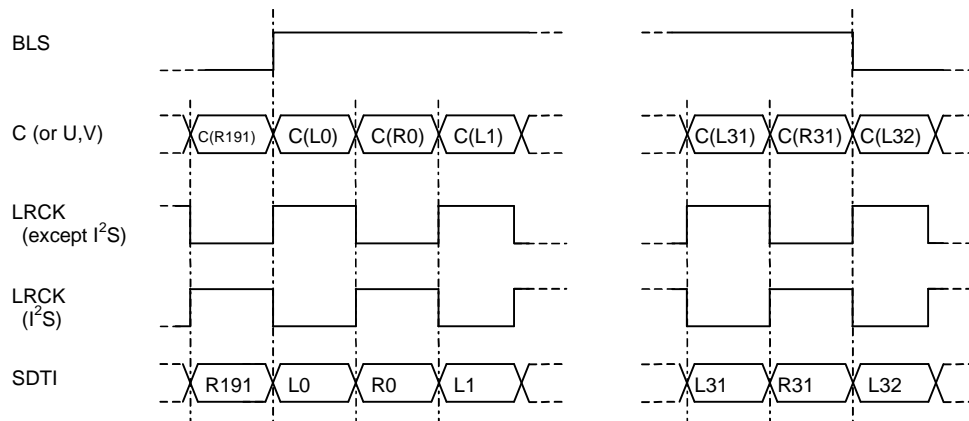

Figure 1. Audio routing mode timing (AKMODE pin = "0")

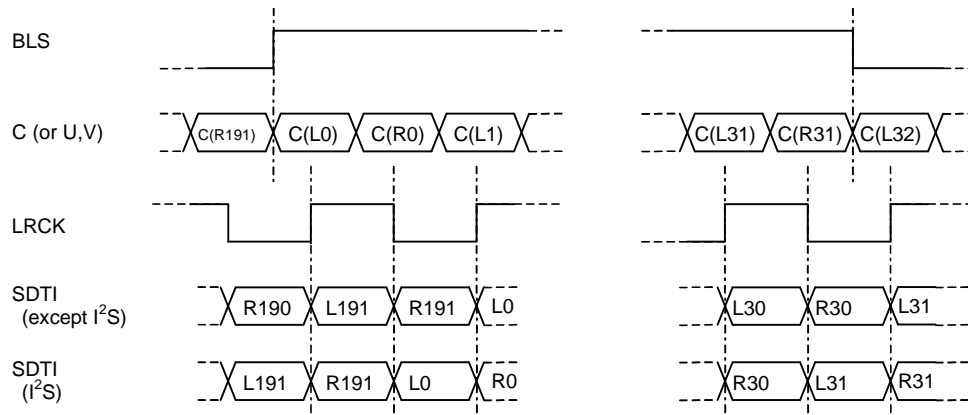

Figure 2. Audio routing mode timing (AKMODE pin = "1")

■ Block Start Timing

Normal mode

In normal mode (TRANS pin = "0"), the block start signal is an output. It goes "H" two bit cycle after the beginning of channel 2 of frame 0 in each block, and stays "H" for the first 32 frames.

Audio Routing Mode (Transparent Mode)

In audio routing mode (transparent mode) (ANS pin = TRANS pin = "1"), the block start becomes an input. Except in I²S mode, a block start signal sampled any time from the first positive BICK edge of the previous left channel to the positive BICK edge preceding the transition of an LRCK indicating the left channel will result in the current left channel being taken as the first sub frame of the current block. See Figure 3 below.

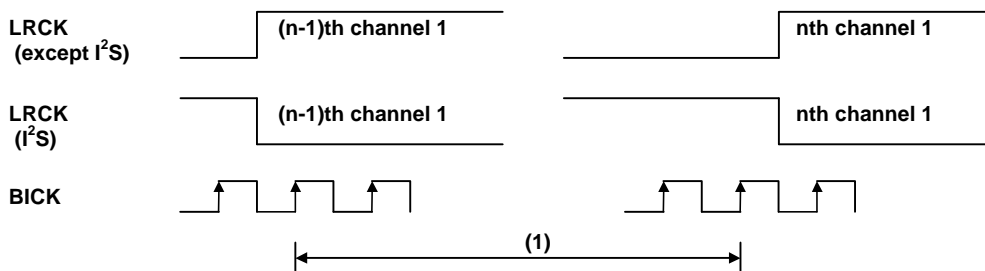

Figure 3. Block start timing in audio routing mode

A block start signal arriving during "(1)" period will result in the usage of "nth channel 1" as the first sub-frame of the block.

■ C, U, V Serial Ports

Normal mode

In normal mode (TRANS pin = “0”), the C, U and V bits are captured (either from the pins, in synchronous mode, or the control registers, in the asynchronous mode) in the sub frame following the audio data. The V bit is set to zero to indicate the audio data is suitable for conversion. See Figure 4 and Figure 5.

Audio routing mode (transparent mode)

In audio routing mode (transparent mode) (ANS pin = TRANS pin = “1”), the C, U and V bits are captured with the same sub-frame as the data to which the C, U and V bits correspond. In all DIF modes except 5 and 7, the C, U and V bits are captured at the first, rising edge of BICK after an LRCK transition. In modes 5 and 7 (I²S), the C, U and V bits are captured at the second rising edge. See Figure 6 and Figure 7.

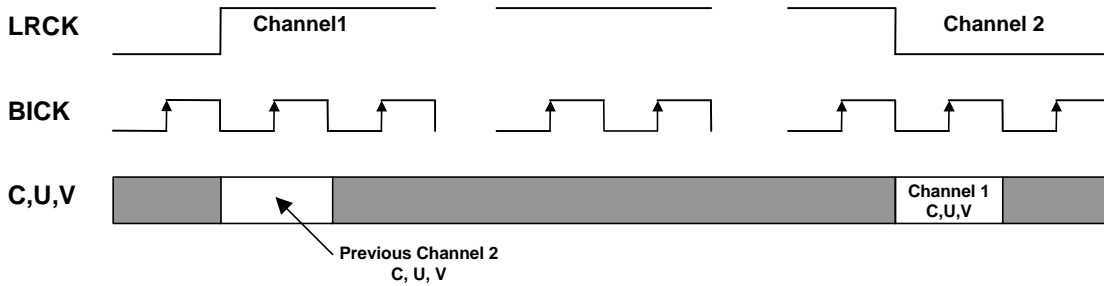

Figure 4. Normal, DIF modes 0, 1, 2, 3, 4, and 6

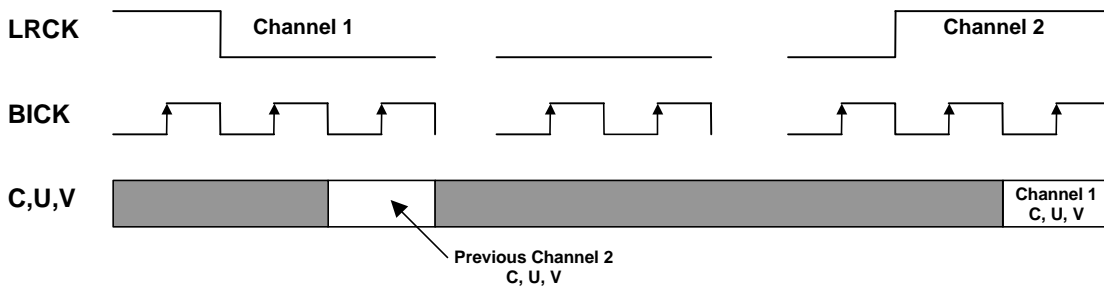

Figure 5. Normal, DIF modes 5 and 7 (I²S)

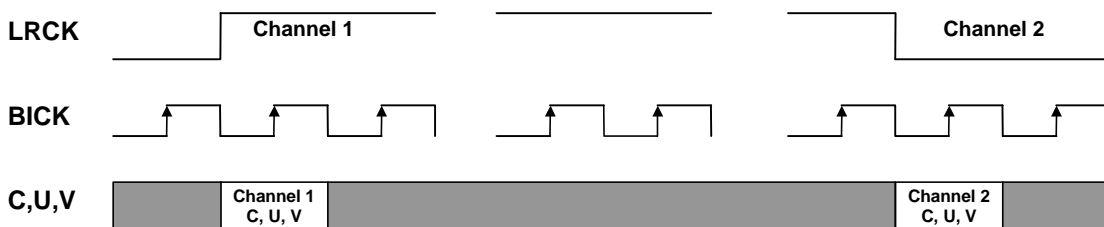

Figure 6. Audio routing, DIF modes 0, 1, 2, 3, 4, and 6

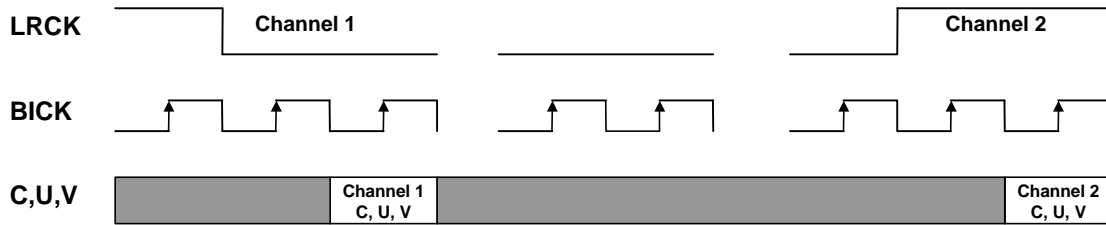

Figure 7. Audio routing, DIF modes 5 and 7 (I²S)

■ Audio Serial Interface

The audio serial interface is used to input audio data and consists of three pins: Bit Clock (BICK), Word Clock (LRCK) & Data pin (SDTI). LRCK indicates the particular channel, left or right. The DIF 2-0 pins in synchronous mode and control registers in asynchronous mode select the particular input mode. In asynchronous mode, DIF2-0 bits are logically Ored with DIF2-0 pins. Audio data format supports 16-24 bits, right justified and left justified modes. The I²S mode is also supported. The AK4103A can be configured in master and slave modes.

| Mode | DIF2 | DIF1 | DIF0 | SDTI | Master / Slave | LRCK | BICK |
|------|------|------|------|-------------------------|----------------|---------|----------------|
| 0 | 0 | 0 | 0 | 16bit, Right justified | Slave | H/L (I) | 32fs-128fs (I) |
| 1 | 0 | 0 | 1 | 18bit, Right justified | Slave | H/L (I) | 36fs-128fs (I) |
| 2 | 0 | 1 | 0 | 20bit, Right justified | Slave | H/L (I) | 40fs-128fs (I) |
| 3 | 0 | 1 | 1 | 24bit, Right justified | Slave | H/L (I) | 48fs-128fs (I) |
| 4 | 1 | 0 | 0 | 24bit, Left justified | Slave | H/L (I) | 48fs-128fs (I) |
| 5 | 1 | 0 | 1 | 24bit, I ² S | Slave | L/H (I) | 50fs-128fs (I) |
| 6 | 1 | 1 | 0 | 24bit, Left justified | Master | H/L (O) | 64fs (O) |
| 7 | 1 | 1 | 1 | 24bit, I ² S | Master | L/H (O) | 64fs (O) |

Table 3. Audio Data Format Modes [NOTE; (I): Input, (O): Output]

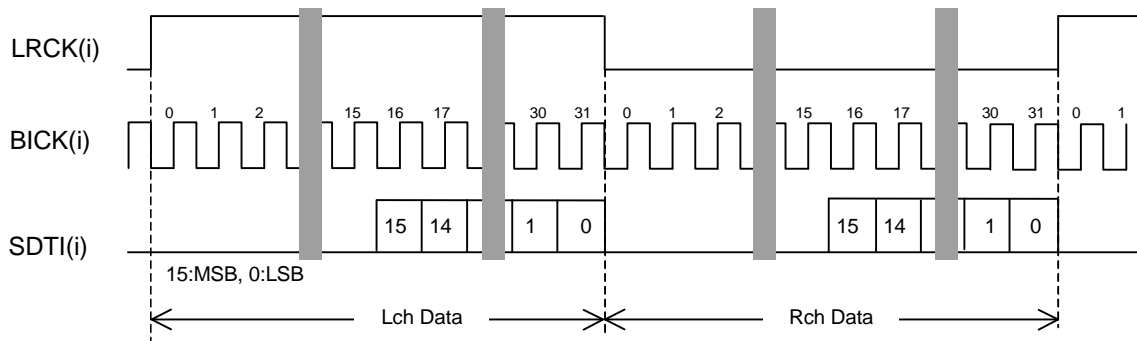

Figure 8. Mode 0 Timing

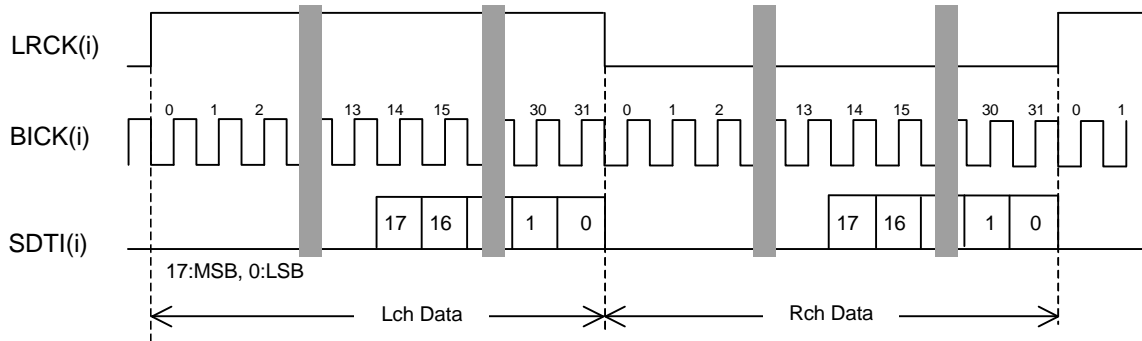

Figure 9. Mode 1 Timing

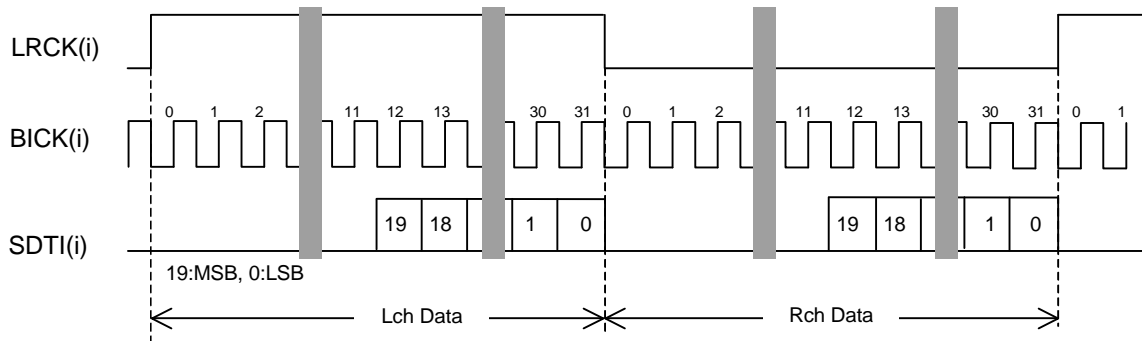

Figure 10. Mode 2 Timing

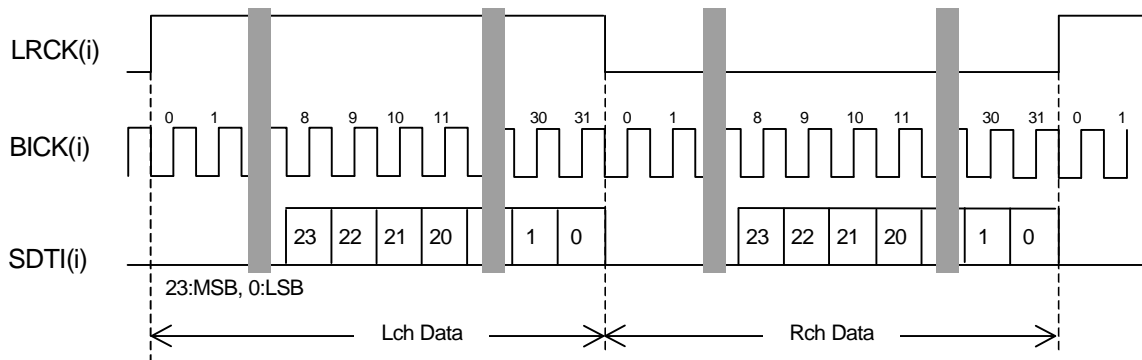

Figure 11. Mode 3 Timing

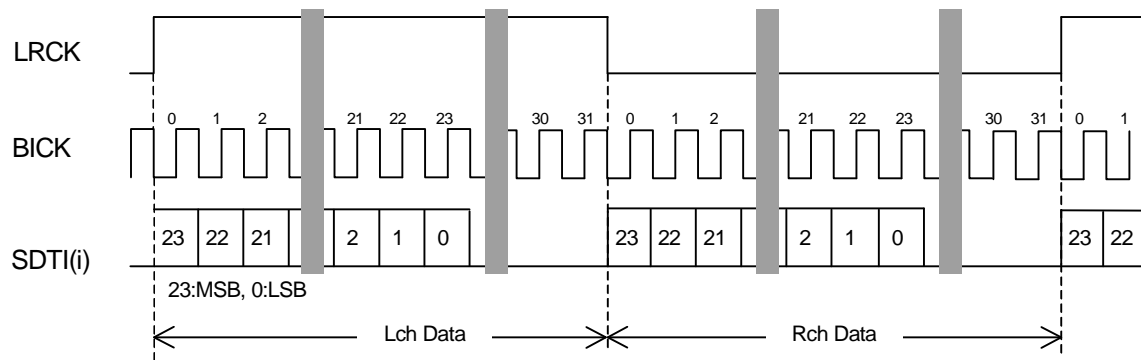

Figure 12. Mode 4, 6 Timing

Mode 4: LRCK, BICK: Input
 Mode 6: LRCK, BICK: Output

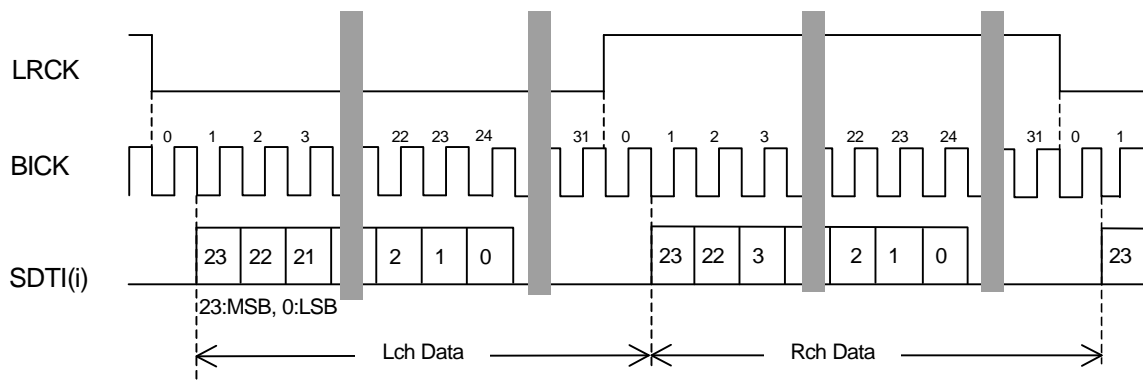

Figure 13. Mode 5, 7 Timing

Mode 5: LRCK, BICK: Input
 Mode 7: LRCK, BICK: Output

■ Sampling frequency setting

Bits 3-0 of Channel Status Byte 3 in consumer mode can be set by FS3-0 pins. Also bits 7-6 of Channel Status Byte 0 and bits 6-3 of Channel Status Byte 4 in professional mode can be set by FS3-0 pins.

| FS[3:0] | Sampling Frequency | Byte 3 Bits 3-0 |
|---------|--------------------|-----------------|
| 0000 | 44.1kHz | 0000 |
| 0001 | Not Indicated | 0001 |
| 0010 | 48kHz | 0010 |
| 0011 | 32kHz | 0011 |
| 0100 | 22.05kHz | 0100 |
| 0101 | Reserved | 0101 |
| 0110 | 24kHz | 0110 |
| 0111 | Reserved | 0111 |
| 1000 | 88.2kHz | 1000 |
| 1001 | Reserved | 1001 |
| 1010 | 96kHz | 1010 |
| 1011 | Reserved | 1011 |
| 1100 | 176.4kHz | 1100 |
| 1101 | Reserved | 1101 |
| 1110 | 192kHz | 1110 |
| 1111 | Reserved | 1111 |

Table 4. Sampling frequency setting (Consumer mode)

| FS[3:0] | Sampling Frequency | Byte 0 Bits 7-6 | Byte 4 Bits 6-3 |
|---------|--------------------|-----------------|-----------------|
| 0000 | Not Defined | 00 | 0000 |
| 0001 | 44.1kHz | 01 | 0000 |
| 0010 | 48kHz | 10 | 0000 |
| 0011 | 32kHz | 11 | 0000 |
| 0100 | Not Defined | 00 | 0000 |
| 0101 | Not Defined | 00 | 0000 |
| 0110 | Not Defined | 00 | 0000 |
| 0111 | Not Defined | 00 | 0000 |
| 1000 | For vectoring | 00 | 1000 |
| 1001 | 22.05kHz | 00 | 1001 |
| 1010 | 88.2kHz | 00 | 1010 |
| 1011 | 176.4kHz | 00 | 1011 |
| 1100 | 192kHz | 00 | 0011 |
| 1101 | 24kHz | 00 | 0001 |
| 1110 | 96kHz | 00 | 0010 |
| 1111 | Not Defined | 00 | 1111 |

Table 5. Sampling frequency setting (Professional mode)

■ Data Transmission Format

Data transmitted on the TX outputs is formatted in blocks as shown in Figure 14. Each block consists of 192 frames. A frame of data contains two sub-frames. A sub-frame consists of 32 bits of information. Each data bit received is coded using a bi-phase mark encoding as a two binary state symbol. The preambles violate bi-phase encoding so they may be differentiated from data. In bi-phase encoding, the first state of an input symbol is always the inverse of the last state of the previous data symbol. For a logic “0”, the second state of the symbol is the same as the first state. For a “1”, the second state is the opposite of the first. Figure 15 illustrates a sample stream of 8 data bits encoded in 16 symbol states.

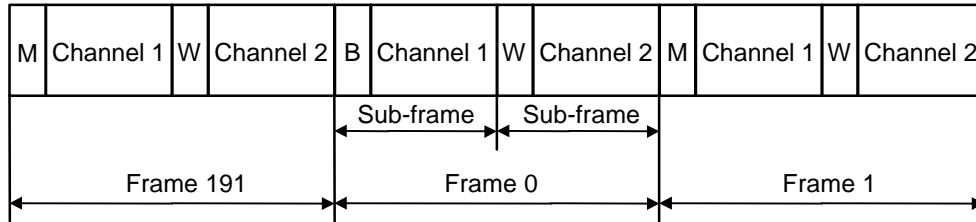

Figure 14. Block format

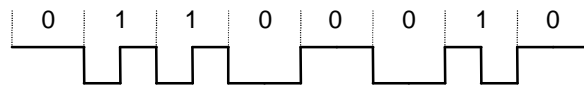

Figure 15. A biphas-encoded bit stream

The sub-frame is defined in Figure 16 below. Bits 0-3 of the sub-frame represent a preamble for synchronization. There are three preambles. The block preamble, B, is contained in the first sub-frame of Frame 0. The channel 1 preamble, M, is contained in the first sub-frame of all other frames. The channel 2 preamble, W, is contained in all of the second sub-frames.

Table 6 below defines the symbol encoding for each of the preambles. Bits 4-27 of the sub-frame contain the 24 bit audio sample in 2’s complement format with bit 27 as the most significant bit. For 16 bit mode, Bits 4-11 are all 0. Bit 28 is the validity flag. This is “H” if the audio sample is unreliable. Bit 29 is a user data bit. Frame 0 contains the first bit of a 192 bit user data word. Frame 191 contains the last bit of the user data word. Bit 30 is a channel status bit. Again frame 0 contains the first bit of the 192 bit word with the last bit in frame 191. Bit 31 is an even parity bit for bits 4-31 of the sub-frame.

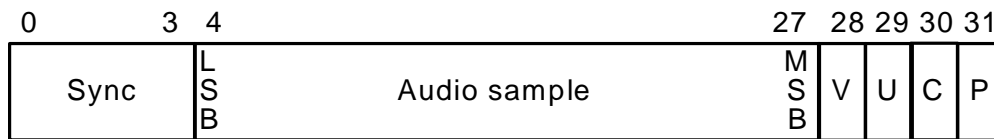

Figure 16. Sub-frame format

The block of data contains consecutive frames transmitted at a state-bit rate of 64 times the sample frequency, fs. For stereophonic audio, the left or A channel data is in channel 1 while the right or B data is in channel 2. For monophonic audio, channel 1 contains the audio data.

| Preamble | Preceding state = 0 | Preceding state = 1 |
|----------|---------------------|---------------------|
| B | 11101000 | 00010111 |
| M | 11100010 | 00011101 |
| W | 11100100 | 00011011 |

Table 6. Sub-frame preamble encoding

■ Line Driver

There is an RS422 line driver on chip. The AES3 specification states that the line driver shall have a balanced output with an internal impedance of 110 ohms $\pm 20\%$ and also requires a balanced output drive capability of 2 to 7 volts peak-to-peak into 110 ohm load. The internal impedance of the RS422 driver along with a series resistors of 56 ohms realizes this requirement. For consumer use(S/PDIF), the specifications require an output impedance of 75 ohms $\pm 20\%$ and a driver level of $0.5 \pm 20\%$ volts peak to peak. A combination of 330 ohms in parallel with 100 ohms realizes this requirement. The outputs can be set to ground by resetting the device or a software mute.

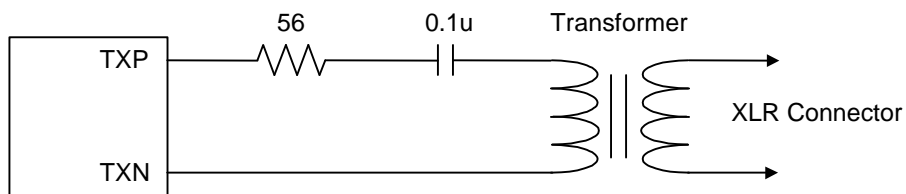

Figure 17. Professional Output Driver Circuit

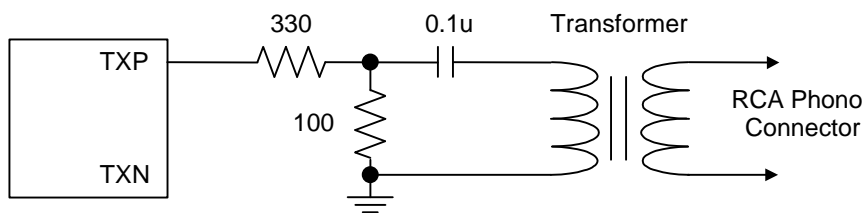
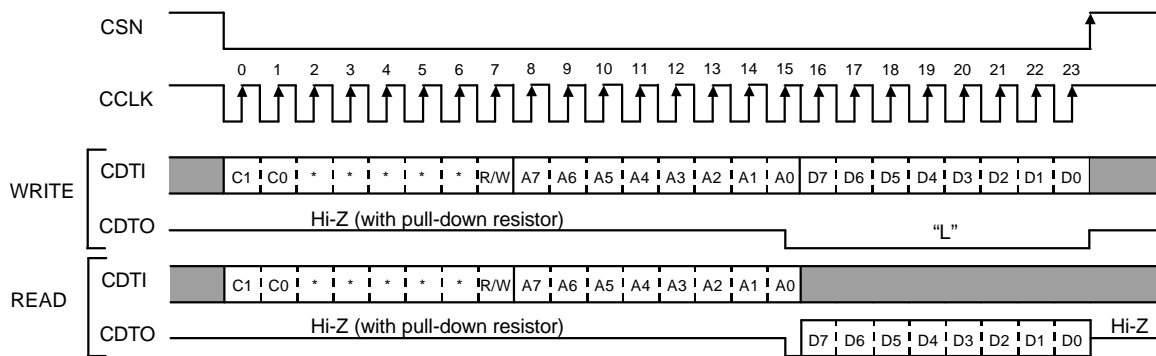

Figure 18. Consumer Output Driver Circuit

■ Serial Control Interface

In asynchronous mode, four of the dual function pins become CSN, CCLK, CDTI and CDTO, a 4 wire microprocessor interface. The internal 18 byte control register can then be read and written. The contents of the control register define, in part, the mode of operation for the AK4103A. Figure 19 illustrates the serial data flow associated with SCI read and write operations. C1-0 bits are the chip address. The AK4103A looks for C1-0 bits to be a “11” before responding to the incoming data. R/W is the Read/ Write bit which is “0” for a read operation and “1” for a write operation. The register address contained in A7-0 bits is decoded to select a particular byte of the control register. D7-0 bits on CDTI pin is the control data coming from the microprocessor during a write operation. D7-0 bits on CDTO pin is the contents of the addressed byte from the control register requested during a read operation. The address and data bits are framed by CSN pin = “0”. During a write operation, each address and data bit is sampled on the rising edge of CCLK. During a read operation, the address bits are sampled on the rising edge of CCLK while data on CDTO is output on the falling edge of CCLK. CCLK has a maximum frequency of 5 MHz.



C1-C0: Chip Address (Fixed to “11”)
 R/W: READ/WRITE (0:READ, 1:WRITE)
 *: Don't care
 A7-A0: Register Address
 D7-D0: Control Data

Figure 19. Control I/F Timing

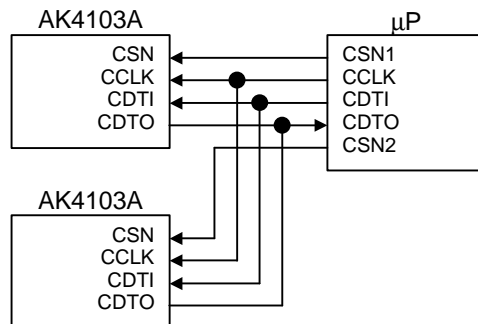

Figure 20. Typical connection with μP

Note: External pull-up resistor should not be attached to CDTO pins since CDTO pin is internally connected to the pull-down resistor.

■ Register Map

| Addr | Register Name | D7 | D6 | D5 | D4 | D3 | D2 | D1 | D0 |
|-------------|--|--------------------|------|------|------|------|------|-------|--------------------|
| 00H | Clock/Format Control | CRCE | DIF2 | DIF1 | DIF0 | CKS1 | CKS0 | MUTEN | RSTN |
| 01H | Validity/fs Control | 0 | 0 | 0 | V1 | FS3 | FS2 | FS1 | FS0 |
| 02H | A-channel C-bit buffer for Byte 0 | CA7 | CA6 | CA5 | CA4 | CA3 | CA2 | CA1 | CA0 |
| 03H | A-channel C-bit buffer for Byte 1 | CA15 | CA14 | CA13 | CA12 | CA11 | CA10 | CA9 | CA8 |
| 04H | A-channel C-bit buffer for Byte 2 | CA23 | CA22 | CA21 | CA20 | CA19 | CA18 | CA17 | CA16 |
| 05H | A-channel C-bit buffer for Byte 3 | CA31 | CA30 | CA29 | CA28 | CA27 | CA26 | CA25 | CA24 |
| 06H- 09H | B-channel C-bit buffer for Byte 0-3 | CB7 ... CB31 | ... | ... | ... | ... | ... | ... | CB0 ... CB24 |
| 0AH- 0DH | A-channel U-bit buffer for Byte 0-3 | UA7 ... UA31 | ... | ... | ... | ... | ... | ... | UA0 ... UA24 |
| 0EH- 11H | B-channel U-bit buffer for Byte 0-3 | UB7 ... UB31 | ... | ... | ... | ... | ... | ... | UB0 ... UB24 |

Table 7. Register Map

Notes:

- (1) In stereo mode, A indicates Left Channel and B indicates Right Channel.
- (2) In asynchronous mode, the DIF2-0 and CKS1-0 bits are logically “ORed” with the DIF2-0 and CKS1-0 pins.
- (3) For addresses from 12H to FFH, data is not written.
- (4) The PDN pin = “L” resets the registers to their default values.

■ Register Definitions

| Addr | Register Name | D7 | D6 | D5 | D4 | D3 | D2 | D1 | D0 |
|------|----------------------|------|------|------|------|------|------|-------|------|
| 00H | Clock/Format Control | CRCE | DIF2 | DIF1 | DIF0 | CKS1 | CKS0 | MUTEN | RSTN |
| | R/W | R/W | R/W | R/W | R/W | R/W | R/W | R/W | R/W |
| | Default | 1 | 0 | 0 | 0 | 0 | 0 | 1 | 1 |

RSTN: Timing Reset.

0: Resets the internal frame and bit counters. Control registers are not initialized.

TXP pin is “H” and TXN pin is “L”. In normal mode, BLS pin is “H”.

1: Normal operation. (Default)

MUTEN: Power Down and Mute for Asynchronous Mode.

0: Power Down Command. Control registers are not initialized.

TXP and TXN pins are “L”. In normal mode, BLS pin is “H”.

1: Normal operation. (Default)

CKS1-0: Master Clock Frequency Select. (See Table 1.)

Default: “00” (Mode 0: MCLK=128fs)

CKS1-0 bits are logically ORed with CKS1-0 pins.

DIF2-0: Audio Data Format. (See Table 3.)

Default: “000” (Mode 0: 16bit right justified)

DIF2-0 bits are logically ORed with DIF2-0 pins.

CRCE: CRCC Enable at professional mode.

0: CRCC is not generated.

1: CRCC is generated at professional mode. In consumer mode, CRCC is not generated. (Default)

| Addr | Register Name | D7 | D6 | D5 | D4 | D3 | D2 | D1 | D0 |
|------|---------------------|----|----|----|-----|-----|-----|-----|-----|
| 01H | Validity/fs Control | 0 | 0 | 0 | V1 | FS3 | FS2 | FS1 | FS0 |
| | R/W | RD | RD | RD | R/W | R/W | R/W | R/W | R/W |
| | Default | 0 | 0 | 0 | 0 | 0 | 0 | 0 | 0 |

FS3-0: Sampling Frequency Select. (See Table 4 and Table 5.)

Default: “0000” (“44.1kHz” in consumer mode; “Not defined” in professional mode.)

V1: Validity Flag.

0: Valid (Default)

1: Invalid

| Addr | Register Name | D7 | D6 | D5 | D4 | D3 | D2 | D1 | D0 |
|---------|--------------------------------------|-----|-----|-----|-----|-----|-----|-----|-----|
| 02H | A-channel C-bit buffer for Byte 0 | CA7 | CA6 | CA5 | CA4 | CA3 | CA2 | CA1 | CA0 |
| 06H | B-channel C-bit buffer for Byte 0 | CB7 | CB6 | CB5 | CB4 | CB3 | CB2 | CB1 | CB0 |
| R/W | | R/W | R/W | R/W | R/W | R/W | R/W | R/W | R/W |
| Default | | 0 | 0 | 0 | 0 | 0 | 1 | 0 | 0 |

C0-7: Channel Status Byte 0
Default: "00100000"

| Addr | Register Name | D7 | D6 | D5 | D4 | D3 | D2 | D1 | D0 |
|---------|--------------------------------------|------|------|------|------|------|------|-----|-----|
| 03H | A-channel C-bit buffer for Byte 1 | CA15 | CA14 | CA13 | CA12 | CA11 | CA10 | CA9 | CA8 |
| 07H | B-channel C-bit buffer for Byte 1 | CB15 | CB14 | CB13 | CB12 | CB11 | CB10 | CB9 | CB8 |
| R/W | | R/W | R/W | R/W | R/W | R/W | R/W | R/W | R/W |
| Default | | 0 | 0 | 0 | 0 | 0 | 0 | 0 | 0 |

C8-15: Channel Status Byte 1
Default: "00000000"

| Addr | Register Name | D7 | D6 | D5 | D4 | D3 | D2 | D1 | D0 |
|---------|--------------------------------------|------|------|------|------|------|------|------|------|
| 04H | A-channel C-bit buffer for Byte 2 | CA23 | CA22 | CA21 | CA20 | CA19 | CA18 | CA17 | CA16 |
| R/W | | R/W | R/W | R/W | R/W | R/W | R/W | R/W | R/W |
| Default | | 0 | 0 | 0 | 1 | 0 | 0 | 0 | 0 |

CA16-23: Channel Status Byte 2 for A-channel
Default: "00001000"

| Addr | Register Name | D7 | D6 | D5 | D4 | D3 | D2 | D1 | D0 |
|---------|--------------------------------------|------|------|------|------|------|------|------|------|
| 08H | B-channel C-bit buffer for Byte 2 | CB23 | CB22 | CB21 | CB20 | CB19 | CB18 | CB17 | CB16 |
| R/W | | R/W | R/W | R/W | R/W | R/W | R/W | R/W | R/W |
| Default | | 0 | 0 | 1 | 0 | 0 | 0 | 0 | 0 |

CB16-23: Channel Status Byte 2 for B-channel
Default: "00000100"

| Addr | Register Name | D7 | D6 | D5 | D4 | D3 | D2 | D1 | D0 |
|---------|--------------------------------------|------|------|------|------|------|------|------|------|
| 05H | A-channel C-bit buffer for Byte 3 | CA31 | CA30 | CA29 | CA28 | CA27 | CA26 | CA25 | CA24 |
| 09H | B-channel C-bit buffer for Byte 3 | CB31 | CB30 | CB29 | CB28 | CB27 | CB26 | CB25 | CB24 |
| R/W | | R/W | R/W | R/W | R/W | R/W | R/W | R/W | R/W |
| Default | | 0 | 0 | 0 | 0 | 0 | 0 | 1 | 0 |

C24-31: Channel Status Byte 3
Default: "01000000"

| Addr | Register Name | D7 | D6 | D5 | D4 | D3 | D2 | D1 | D0 |
|---------|-------------------------------------|-----|-----|-----|-----|-----|-----|-----|------|
| 0AH-0DH | A-channel U-bit buffer for Byte 0-3 | UA7 | ... | ... | ... | ... | ... | ... | UA0 |
| | | ... | ... | ... | ... | ... | ... | ... | UA24 |
| 0EH-11H | B-channel U-bit buffer for Byte 0-3 | UB7 | ... | ... | ... | ... | ... | ... | UB0 |
| | | ... | ... | ... | ... | ... | ... | ... | UB24 |
| R/W | | R/W | R/W | R/W | R/W | R/W | R/W | R/W | R/W |
| Default | | 0 | 0 | 0 | 0 | 0 | 0 | 0 | 0 |

U0-31: User Data
Default: all "0"

■ Default values of control registers

| Bits | Default | | |
|----------------|-----------|------------------------|--|
| CRCE | 1 | CRCC is generated. | |
| DIF2-0 | 000 | 16bit, Right justified | |
| CKS1-0 | 00 | MCLK=128fs | |
| V1 | 0 | Valid data | |
| FS3-0 | 0000 | fs=44.1kHz | |
| MUTEN | 1 | Normal Operation | |
| RSTN | 1 | Normal Operation | |
| Channel Status | | | |
| Byte0 | - Bit0 | 0 | Consumer Mode |
| | - Bit1 | 0 | Audio Mode |
| | - Bit2 | 1 | No Copyright |
| | - Bit3-5 | 000 | No Emphasis |
| | - Bit6-7 | 00 | Mode 0 |
| Byte1 | - Bit0-7 | 00000000 | General Category Code |
| Byte2 | - Bit0-3 | 0000 | Source Number: Don't care |
| | - Bit4-7 | 1000 0100 | Channel A Source channel Channel B Source channel |
| Byte3 | - Bit0-3 | 0100 | fs=48kHz |
| | - Bit4-5 | 00 | Standard Clock Accuracy |
| | - Bit6-7 | 00 | |
| User Data | All zeros | | |

Table 8. Default Values of Control Register

PACKAGE

24pin VSOP (Unit: mm)

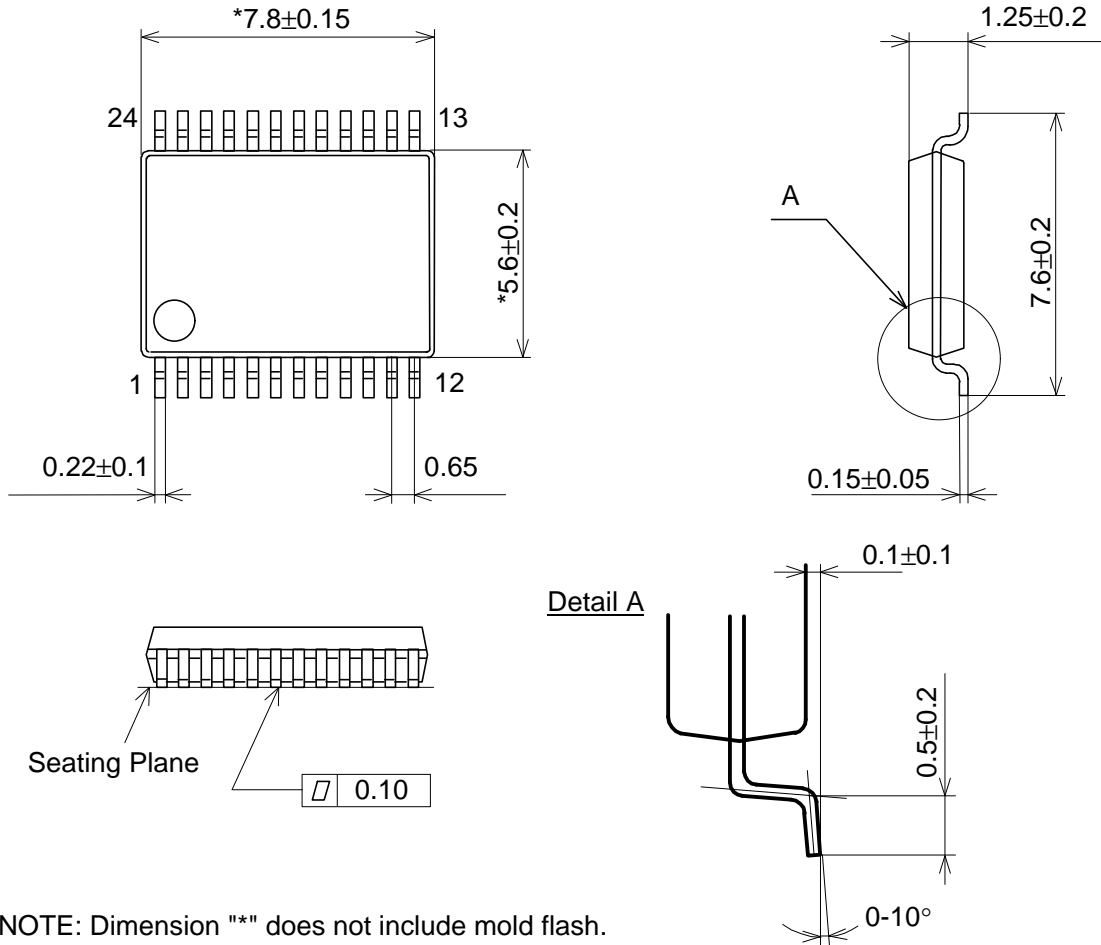

NOTE: Dimension "*" does not include mold flash.

■ Package & Lead frame material

- Package molding compound: Epoxy
- Lead frame material: Cu
- Lead frame surface treatment: Solder plate (Pb free)

| |
|----------------|
| MARKING |
|----------------|

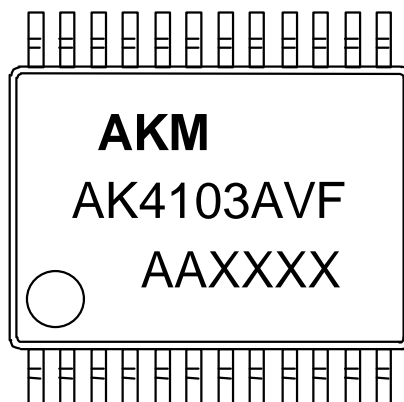

Contents of AAXXXX

AA: Lot#

XXXX: Date Code

IMPORTANT NOTICE

- These products and their specifications are subject to change without notice. Before considering any use or application, consult the Asahi Kasei Microsystems Co., Ltd. (AKM) sales office or authorized distributor concerning their current status.
- AKM assumes no liability for infringement of any patent, intellectual property, or other right in the application or use of any information contained herein.
- Any export of these products, or devices or systems containing them, may require an export license or other official approval under the law and regulations of the country of export pertaining to customs and tariffs, currency exchange, or strategic materials.
- AKM products are neither intended nor authorized for use as critical components in any safety, life support, or other hazard related device or system, and AKM assumes no responsibility relating to any such use, except with the express written consent of the Representative Director of AKM. As used here:
 - (a) A hazard related device or system is one designed or intended for life support or maintenance of safety or for applications in medicine, aerospace, nuclear energy, or other fields, in which its failure to function or perform may reasonably be expected to result in loss of life or in significant injury or damage to person or property.
 - (b) A critical component is one whose failure to function or perform may reasonably be expected to result, whether directly or indirectly, in the loss of the safety or effectiveness of the device or system containing it, and which must therefore meet very high standards of performance and reliability.
- It is the responsibility of the buyer or distributor of an AKM product who distributes, disposes of, or otherwise places the product with a third party to notify that party in advance of the above content and conditions, and the buyer or distributor agrees to assume any and all responsibility and liability for and hold AKM harmless from any and all claims arising from the use of said product in the absence of such notification.