



AK4516A

3V 16bit ADC&DAC with built-in PGA

FEATURE

- 1 . Resolution: 16 bits
- 2 . Recording Function
 - Analog Input PGA (Programmable Gain Amp)
 - Peak-Meter Output
 - Overflow Flag Output
 - Auto Limiter Circuit
 - Auto Recovery Circuit
 - HPF($f_c=3.4\text{Hz}$) for offset cancel
- 3 . Playback Function
 - Digital De-emphasis Filter($t_c=50/15\mu\text{s}$, $f_s=32\text{kHz}$, 44.1kHz , 48kHz)
- 4 . Analog-Through Mode
- 5 . Power Management
- 6 . ADC Input (Including the PGA)
 - Single-ended Input
 - Input Level: 1.7Vpp ($=0.57\times V_A$, $V_A=3\text{V}$)
 - THD+N: -85dB
 - DR,S/N: 90dB
- 7 . DAC Output
 - Single-ended Output
 - Output Level: 1.8Vpp ($=0.6\times V_A$, $V_A=3\text{V}$, $R_L\geq 10\text{k}\Omega$)
 - Frequency Response: $\pm 0.5\text{dB}$ ($\sim 20\text{kHz}$)
 - THD+N: -86dB
 - DR,S/N: 90dB
- 8 . Master Clock: $256f_s/384f_s$
- 9 . Audio Data Format
 - ADC: 16bit, MSB first,
MSB justified, IIS, LSB justified(only BICK=64fs correspondent)
 - DAC: 16bit, MSB first,
MSB justified, IIS, MSB justified
- 10 . Ta: $-20\sim 85^\circ\text{C}$
- 11 . Power Supply: $2.5\sim 3.6\text{V}$
- 12 . Power Dissipation: 18mA
- 13 . 24pinVSOP (0.65mm Pitch)

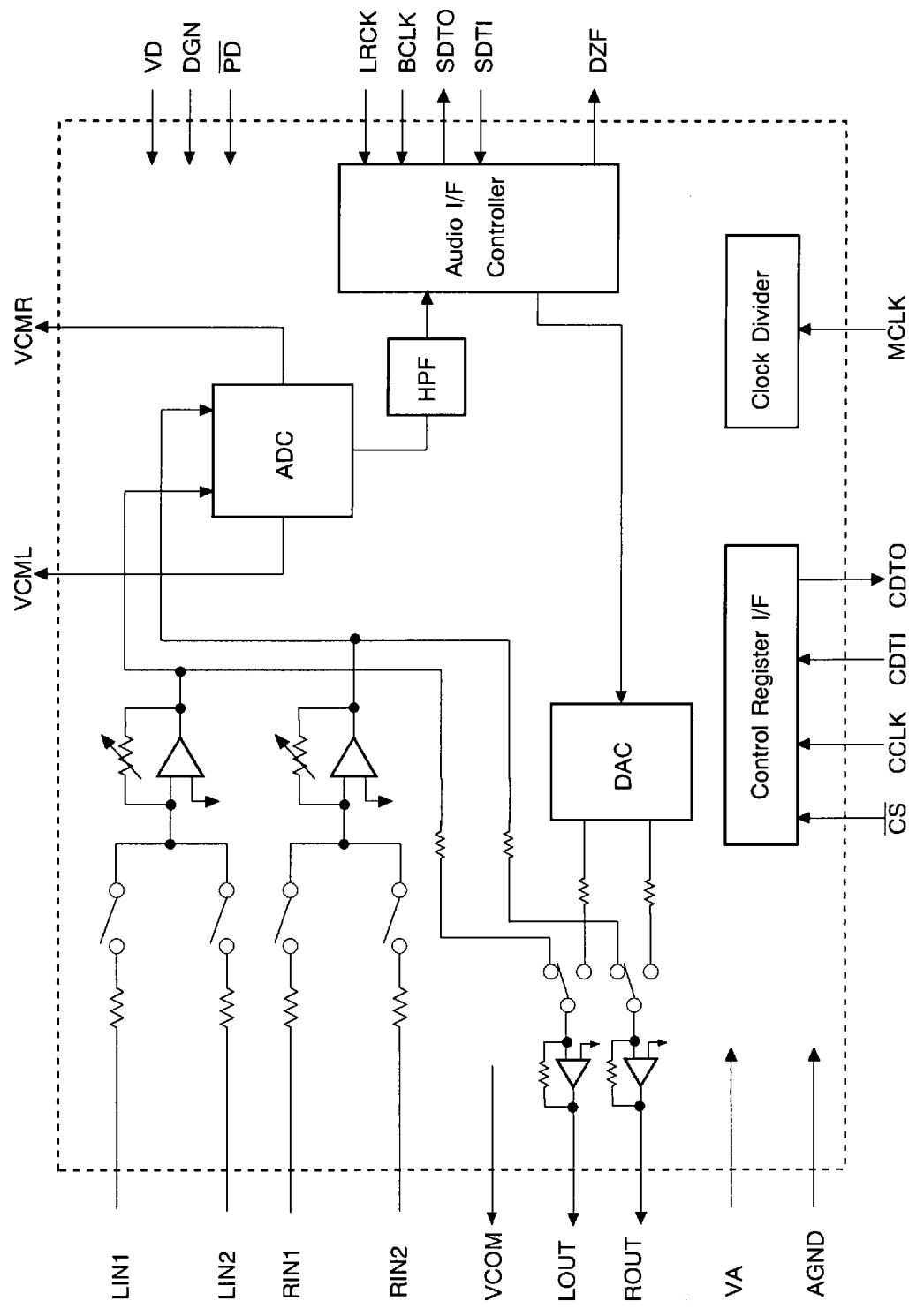

■ Ordering Guide

AK4516AVF	-20~+85°C	24pin VSOP(0.65mm Pitch)
AKD4516A	Evaluation Board	

■ Pin Layout

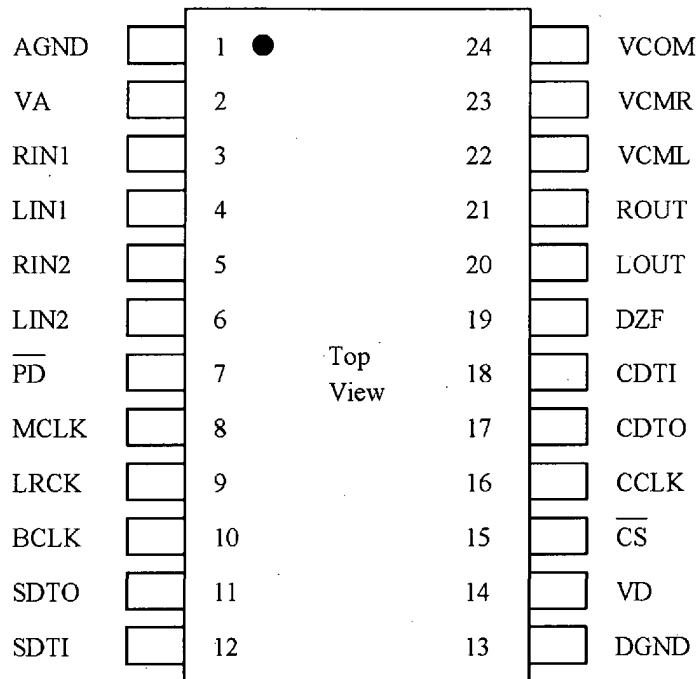

PIN/FUNCTION			
No.	Pin Name	I/O	Function
1	AGND	-	Analog Ground pin
2	VA	-	Analog Power Supply Pin, +3V
3	RIN1	I	Rch #1 input pin
4	LIN1	I	Lch #1 input pin
5	RIN2	I	Rch #2 input pin
6	LIN2	I	Lch #2 input pin
7	\overline{PD}	I	Reset & Power down Pin
8	MCLK	I	Master Clock Input Pin
9	LRCK	I	Input/Output Channel Clock Pin
10	BCLK	I	Audio Serial Data Clock Pin
11	SDTO	O	Audio Serial Data Output Pin
12	SDTI	I	Audio Serial Data Input Pin
13	DGND	-	Digital Ground Pin
14	VD	-	Digital Power Supply Pin, +3V
15	\overline{CS}	I	Chip Select Pin
16	CCLK	I	Control Clock Input Pin
17	CDTO	O	Control Data Output Pin
18	CDTI	I	Control Data Input Pin
19	DZF	O	Zero Detect Pin
20	LOUT	O	Lch analog output pin
21	ROUT	O	Rch analog output pin
22	VCML	O	Lch Common Voltage Output Pin, 0.5 x VA Don't be connected with external circuit.
23	VCMR	O	Rch Common Voltage Output Pin, 0.5 x VA Don't be connected with external circuit.
24	VCOM	O	Common Voltage Output Pin, 0.5 x VA Don't be connected with external circuit.

ABSOLUTE MAXIMUM RATING

(AGND,DGND=0V; Note 1)

Parameter	Symbol	min	max	Units
Power Supplies: Analog	VA	-0.3	6.0	V
Digital	VD	-0.3	6.0	V
VD-VA	ΔVDA	-	0.3	V
Input Current (Any pin except supplies.)	IIN	-	± 10	mA
Analog Input Voltage LIN1,LIN2,RIN1,RIN2	VINA	-0.3	VA+0.3	V
Digital Input Voltage	VIND	-0.3	VA+0.3	V
Ambient Temperature	Ta	-20	85	°C
Storage Temperature	Tstg	-65	150	°C

Note 1 . All Voltage with respect to ground.

RECOMMENDED OPERATING CONDITIONS

(AGND,DGND=0V; Note1)

Parameter		Symbol	min	typ	max	Units
Power Supplies	Analog	VA	2.5	3.0	3.6	V
	Digital	VD	2.5	3.0	VA	V

Note 1 . All Voltage with respect to ground

ANALOG CHARACTERISTICS

(Ta=25°C; VA,VD=3.0V; fs=44.1kHz; Signal Frequency=1kHz; Measurement Frequency=10Hz~20kHz ; S/(N+D), DR, S/N are specification toward full scale.signal; Unless otherwise specified)

Parameter		min	typ	max	units
Input PGA(IPGA) Characteristics:					
Input Voltage(LIN1,LIN2,RIN1,RIN2=0.57xVA)(Note 2)		1.53	1.7	1.87	Vpp
Input Resistance		25	40	60	kΩ
Step Size	MIC	LINE			
	+28dB~-8dB	+8.0dB~-28dB	0.1	0.5	dB
	-8dB~-32dB	-28dB~-52dB	0.1	1	dB
	-32dB~-40dB	-52dB~-60dB	0.1	2	dB
	-40dB~-52dB	-60dB~-72dB	0.1	4	dB
ADC Analog Input Characteristics : (Note 3)					
Resolution				16	Bits
S/(N+D) (-2dB Input)		75	85		dB
DR (-60dB Input, A-Weighted)		84	90		dB
S/N (A-Weighted)		84	90		dB
Interchannel Isolation		80	90		dB
Interchannel Gain Mismatch			0.2	0.5	dB
DAC Analog Output Characteristics:(Note 4)					
Resolution				16	Bits
S/(N+D)		75	86		dB
DR (-60dB Output, A-Weighted)		84	90		dB
S/N (A-Weighted)		84	90		dB
Interchannel Isolation		90	100		dB
Interchannel Gain Mismatch			0.1	0.3	dB
Output Voltage (AOUT=0.6 x VA) (Note 2)		1.62	1.8	1.98	Vpp
Load Resistance		10			kΩ
Power Supply					
Power supply: VA+VD					
Normal Operation (\overline{PD} ="H")					
AD+DA (PM0=1,PM1=1,PM2=1,PM3=0)			18	27	mA
AD (PM0=1,PM1=1,PM2=0,PM3=0)			11	17	mA
DA (PM0=0,PM1=0,PM2=1,PM3=0)			9	14	mA
Power-down-mode(\overline{PD} ="L") (Note 5)			10	100	uA

Note 2 . Analog Input and Output voltage (Full-Scale voltage:0dB) scale with VA.

IPGA: 0.57 x VA(typ.), DAC : 0.6 x VA(typ).

3 . ADC is input from LIN1/RIN1 or LIN2/RIN2 and it measures included in IPGL/IPGR. The value of IPGL/IPGR is set 0dB.

Internal HPF removes offset in the ADC, IPGL/IPGR.

4 . Measured by AD725C(SHIBASOKU), RMS mode.

5 . In case of the power-down mode, all digital input pins including clock(MCLK, BCLK, LRCK) pins are held VD or DGND.

FILTER CHARACTERISTICS

(Ta=25°C; VA,VD=2.5~3.6V; fs=44.1kHz; DEM bit="0")

Parameter	Symbol	min	typ	max	Units	
ADC Digital Filter (LPF):						
Passband (Note 6)	±0.1dB	PB	0	16.5	kHz	
	-0.55dB				19.0	kHz
	-1.2dB				20.0	kHz
Stopband	SB	26.0			kHz	
Passband Ripple	PR			±0.1	dB	
Stopband Attenuation	SA	68			dB	
Group Delay (Note 7)	GD		16.1		1/fs	
Group Delay Distortion	ΔGD		0		us	
ADC Digital Filter (HPF):						
Frequency Response (Note 6)	-3.0dB	FR		3.4	Hz	
	-0.5dB				10	Hz
	-0.1dB				22	Hz
DAC Digital Filter:						
Passband (Note 6)	±0.1dB	PB	0	22.05	20.0	
	-6.0dB				kHz	
Stopband	SB	24.1			kHz	
Passband Ripple	PR			±0.06	dB	
Stopband Attenuation	SA	43			dB	
Group Delay (Note 7)	GD		14.7		1/fs	
DAC Digital Filter + Analog Filter						
Frequency Response 0~20.0kHz	FR		±0.5		dB	

Note 6 .The passband and stopband frequencies scale with fs (system sampling rate).

For example, ADC is $PB=0.431*fs(@-0.55dB)$, DAC is $PB=0.454*fs(@-0.1dB)$.

7 .The calculating delay time which occurred by digital filtering. This time is from the input of analog signal to setting the 16 bit data of both channels to the output register for ADC.

For DAC, this time is from setting the 16 bit data of both channels on input register to the output of analog signal.

DC CHARACTERISTICS

(Ta=25°C; VA,VD=2.5~3.6V)

Parameter	Symbol	min	typ	max	units
High-Level Input Voltage	VIH	70%VD	-	-	V
Low-Level Input Voltage	VIL	-	-	30%VD	V
High-Level Output Voltage (Iout=-400uA)	VOH	VD-0.4	-	-	V
Low-Level Output Voltage (Iout=400uA)	VOL	-	-	0.4	V
Input Leakage Current	Iin	-	-	±10	uA

SWITCHING CHARACTERISTICS

(Ta=25°C; VA,VD=2.5~3.6V; CL=20pF)

Parameter	Symbol	min	typ	max	Units
Control Clock Frequency					
Master Clock (MCLK) 256fs:	fCLK	7.68	11.2896	12.8	MHz
Pulse Width Low	tCLKL	28			ns
Pulse Width High	tCLKH	28			ns
384fs:	fCLK	11.52	16.9344	19.2	MHz
Pulse Width Low	tCLKL	23			ns
Pulse Width High	tCLKH	23			ns
Channel Select Clock(LRCK) Frequency	fs	30	44.1	50	kHz
Duty		45	50	55	%
Audio Interface Timing					
BCLK period	tBLK	312.5			ns
BCLK Pulse Width Low	tBLKL	130			ns
Pulse Width High	tBLKH	130			ns
LRCK Edge to BCLK "↑"	tLRB	50			ns
BCLK "↑" to LRCK Edge	tBLR	50			ns
LRCK to SDTO(MSB) Delay Time	tLRM			80	ns
BCLK "↓" to SDTO Delay Time	tBSD			80	ns
SDTI Latch Hold Time	tSDH	50			ns
SDTI Latch Set up Time	tSDS	50			ns
Control Interface Timing					
CCLK Period	tCCK	200			ns
CCLK Pulse Width Low	tCCKL	80			ns
Pulse Width High	tCCKH	80			ns
CDATA Latch Set Up Time	tCDS	50			ns
CDATA Latch Hold Time	tCDH	50			ns
CS High Level Time	tCSW	150			ns
CS "↓" to CCLK "↑"	tCSS	50			ns
CCLK "↑" to CS "↑"	tCSH	50			ns
CDTO Output Delay Time	tDCD			70	ns
CS "↑" to CDTO(Hi-Z)Time (Note 8)	tCCZ			70	ns
Reset Timing					
PD Pulse Width	tPDW	150			ns
PD "↑" to SDTO Delay Time	tPDV		8224		1/fs

Note 8 .RL=1kΩ/10% Change (Pull-up operates for VD)

■ Timing Diagram

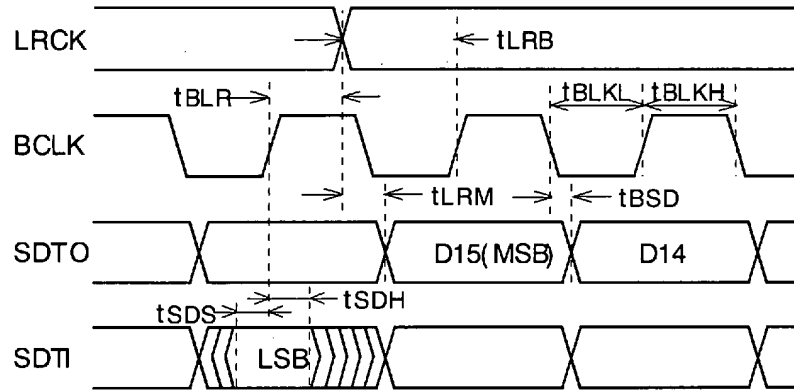

Audio Data Input/Output Timing

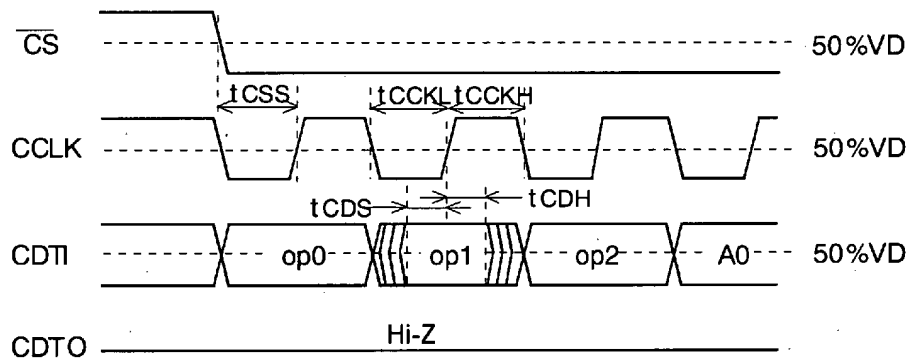

Command Input Timing in WRITE/READ

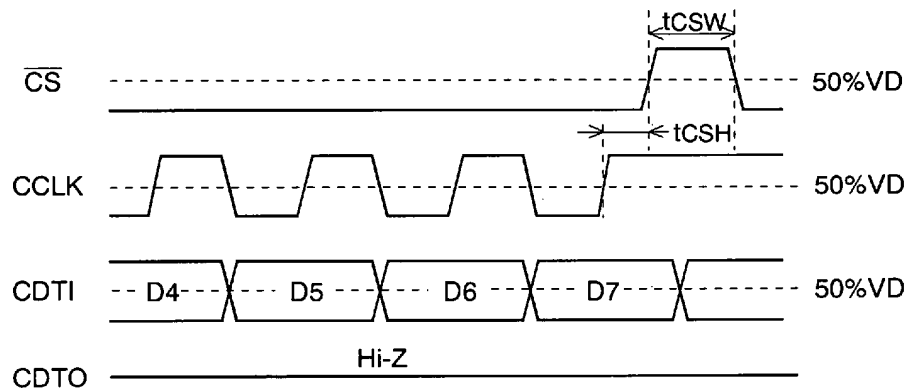

Data Input Timing in WRITE

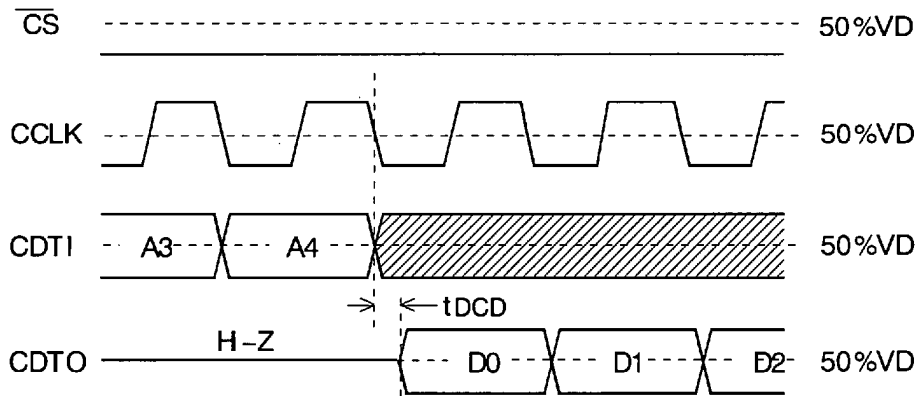

Data Output Timing 1 in READ

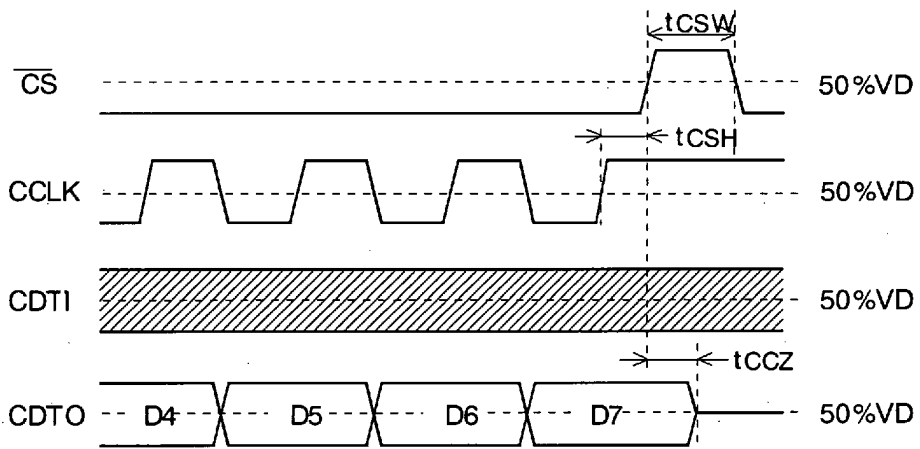

Data Output timing 2 in READ

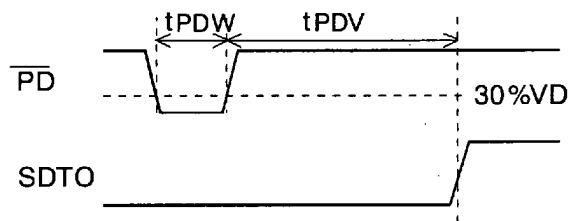

Reset Timing

OPERATION OVERVIEW

■ System Clock

The clocks which are required to operate are MCLK(256fs/384fs), LRCK(fs), BCLK(32fs~). The master clock (MCLK) should be synchronized with LRCK but the phase is free of care.

The MCLK can be input 256fs or 384fs. When 384fs is input, the internal master clock is divided into 2/3 automatically. *fs is sampling frequency.

All external clocks (MCLK, BCLK, LRCK) should always be present whenever IPGA or ADC or DAC is in operation. If these clocks are not provided, the AK4516A may draw excess current and it is not possible to operate properly because utilizes dynamic refreshed logic internally. If the external clocks are not present, the AK4516A should be in the power-down mode. (Please refer to the "Mode Control 1" section.)

■ System Reset

AK4516A should be reset once by bringing $\overline{\text{PD}}$ pin "L" upon power-up. The internal timing starts clocking by LRCK "↑" after exiting reset by MCLK. After the system reset operation, the all internal AK4516A registers are initial value.

■ Zero detection

When the input data at both channels are continuously zeros for 8192 LRCK cycles, DZF goes to "H". DZF immediately goes to "L", if the input data are not zero. When the DAC is power-down, DZF becomes to "L".

■ Digital High Pass Filter(HPF)

The ADC has HPF for the DC offset cancel. The cut-off frequency of HPF is 3.4Hz(@fs=44.1kHz) and it is -0.1dB at 22Hz. It also scales with the sampling frequency(fs).

■ Audio Serial Interface Format

Data is shifted in/out the SDTI/SDTO pins using BCLK and LRCK inputs. Four serial data are selected by the DIF0 and DIF1 pins as shown in Table 1 . In all modes, the serial data is MSB-first, 2's compliment format and it is latched by "↑" of BCLK.

When DIF1="0" and DIF0="1", only BCLK=64fs is acceptable.

No.	DIF1	DIF0	SDTO(ADC)	SDTI(DAC)	BCLK	Figure
0	0	0	MSB justified	LSB justified	≥32fs	Figure 1
1	0	1	LSB justified	LSB justified	= 64fs	Figure 2
2	1	0	MSB justified	MSB justified	≥32fs	Figure 3
3	1	1	I ² S compatible	I ² S compatible	≥32fs	Figure 4

RESET

Table 1 . Audio Data Format

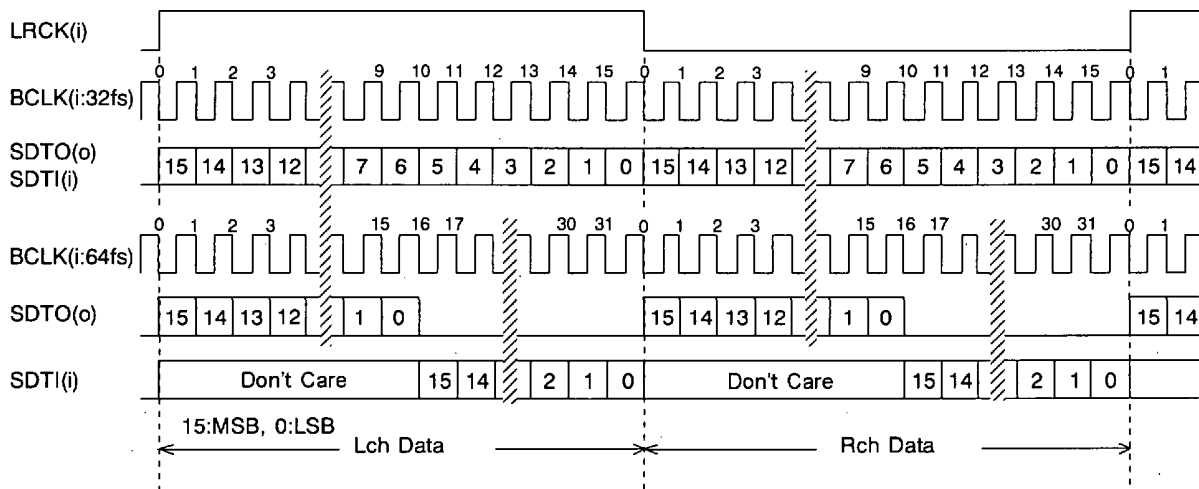

Figure 1. Audio Data Timing (No.0)

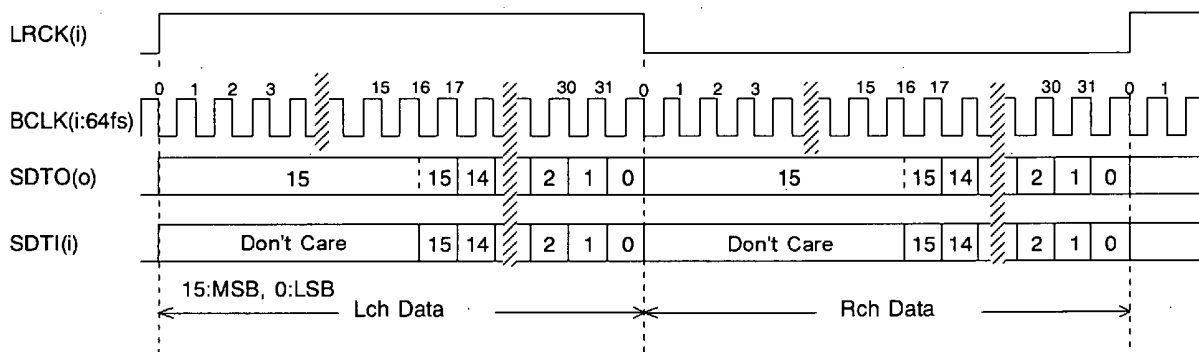

Figure 2. Audio Data Timing (No.1)

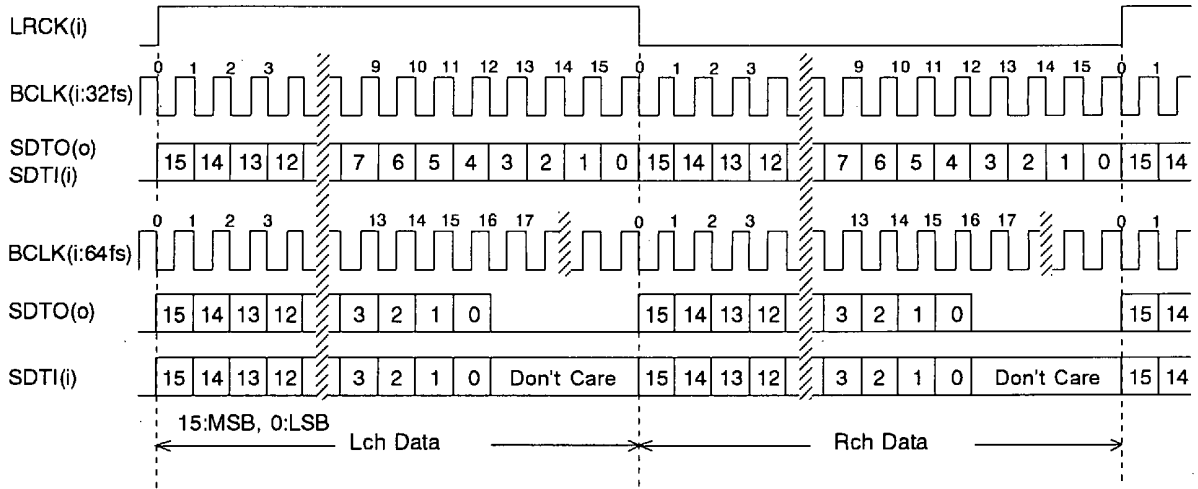

Figure 3. Audio Data Timing (No.2)

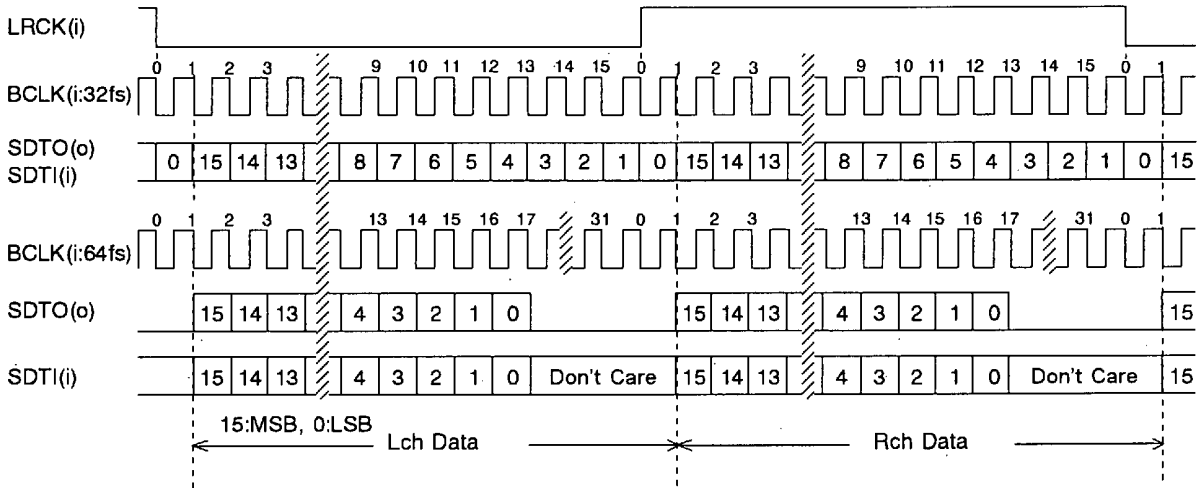

Figure 4. Audio Data Timing (No.3)

■ Control Register R/W Timing

The data on the 4 wires serial interface consists of op-code(3bit), address(LSB-first, 5bit) and control data (LSB-first, 8bit). The transmitting data is output to each bit by "↓" of CCLK, the receiving data is latched by "↑" of CCLK. Writing data becomes effective by "↑" of \overline{CS} . Reading data becomes Hi-Z(floating) by "↑" of \overline{CS} . \overline{CS} should be held to "H" at no access. In case of connecting between CDTI and CDTO, the I/F can be also controlled by 3-wires.

CCLK always needs 16 edges of "↑" during \overline{CS} ="L". Reading/Writing of the address except 00H~0DH are inhibited.

Reading/Writing of the control registers by except op0=op1="1" are invalid.

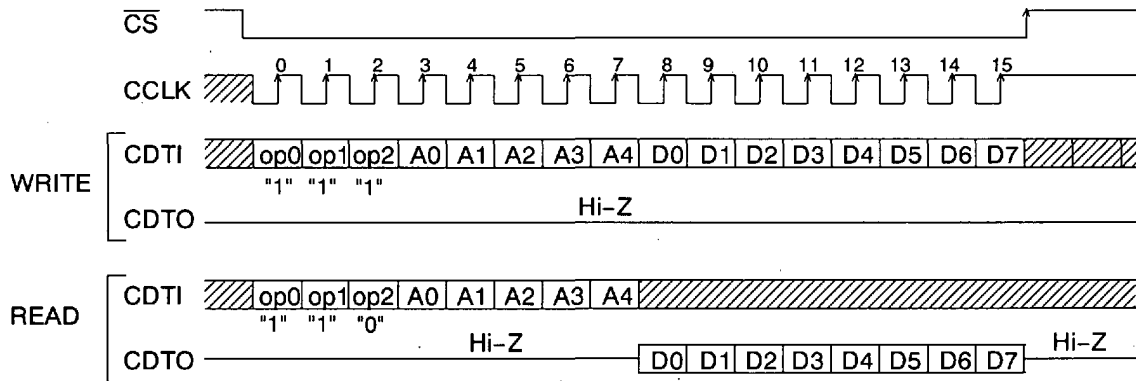

- op0- op2: Op- code (111:WRITE, 110:READ)
- A0- A4: Address
- D0- D7: Control Data

Figure 5 . Control Data Timing

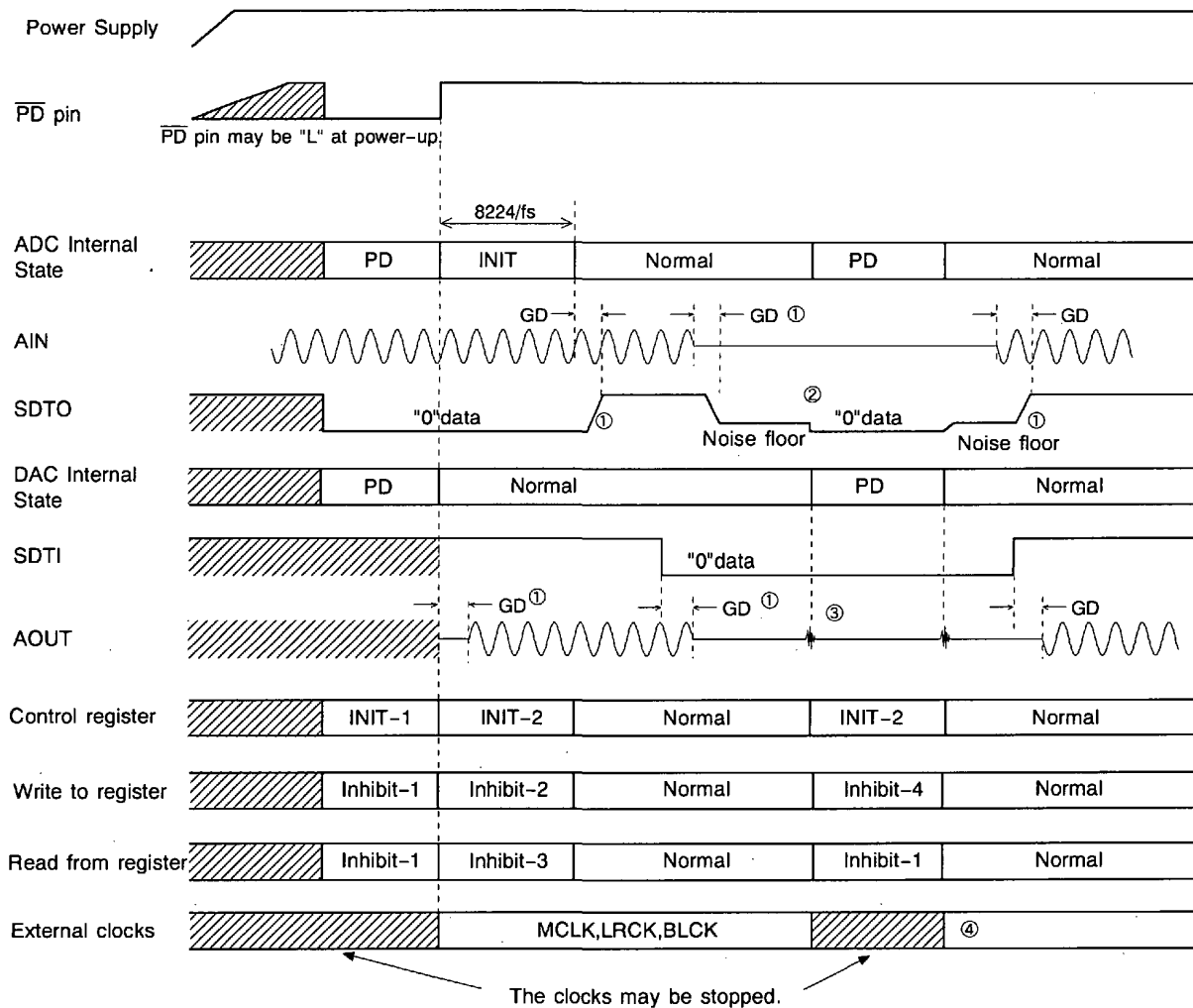

- INIT: Initializing. At this time, ZFIPL and ZFIPR are "0". When these flags becomes "1", INIT process has completed.
 - PD: Power-down state. ADC is output "0", analog output of DAC goes floating.
 - INIT-1: Initializing all registers.
 - INIT-2: Initializing read only registers in control registers.
 - Inhibit-1: Inhibits writing and reading to all control registers.
 - Inhibit-2: Enable writing to control registers except "Mode Control 1 (01H)" register.
 - Inhibit-3: Enable reading from control registers.
 - Inhibit-4: Enable writing to only "Mode Control 1 (01H)" register of the control registers.
- Note: Please refer to "explanation of register" about the condition of each register.

- ① Digital output corresponding to analog input and analog output corresponding to digital input have the group delay(GD).
- ② If the analog signal does not be input, the digital outputs have the offset to the op-amp of input and some offset error of the internal ADC.
- ③ A few noise occurs at the "↓↑" of \overline{PD} signal.
Please mute the analog output externally if the noise influences the system application.
- ④ When the external clocks are stopped, the AK4516A should be in the power-down mode.

Figure 6 .Power-up/Power-down Timing Example

■ Operation mode explanation

The AK4516A can perform the limiter operation and the recovery operation automatically. There are three operation modes.

1. Manual Mode

The manual mode is used when the AK4516A mode is changed (for example, when the input pin or the De-emphasis etc setting is changed) or the recording level is adjusted from uP writing operation by manual. In case of the semi-auto or the full-auto modes, it is impossible to set up a part of the register.
(Refer to "Semi-auto mode", "Full-auto mode" section).

2. Semi-auto Mode

The semi-auto mode is the mode that uses the AK4516A auto limiter function, and the recovery operation is processed by uP or DSP etc.

During the semi-auto mode, writing to the following registers from uP is inhibited.

- LRGA, LTM1-0, ZELM, LMTH1-0, LMAT2-0

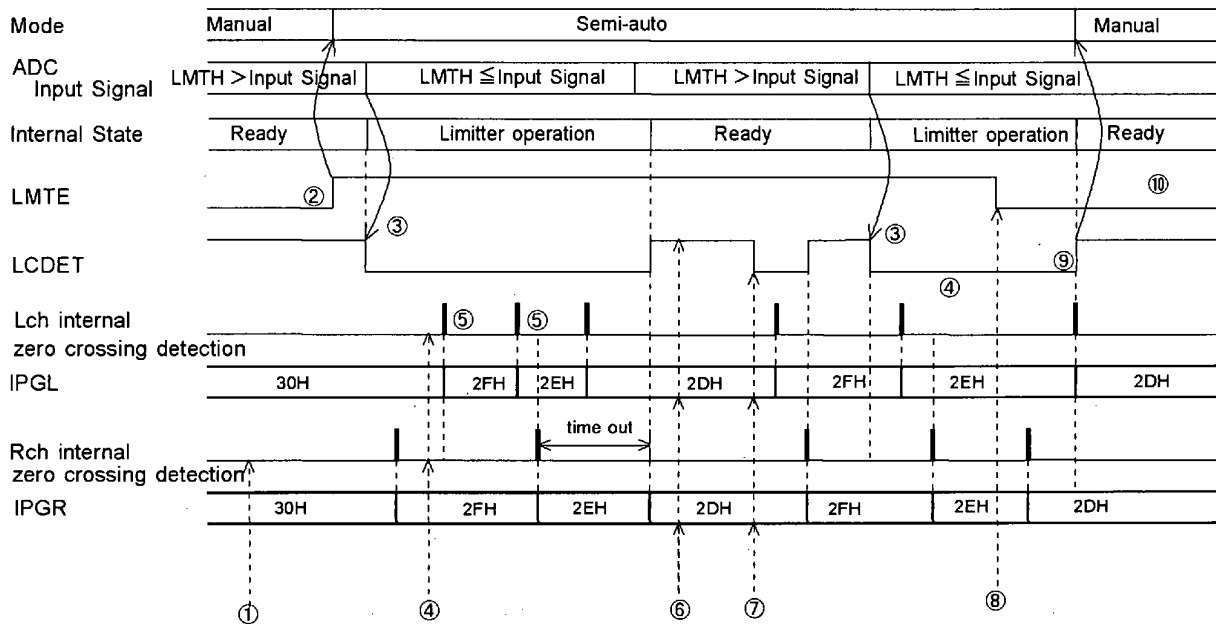

Figure 7 . Control example of semi-auto mode operation(LMAT = 1 step, ZENM=ZELM="1")

- ① Setting up the registers for the semi-auto mode operation.
(LTM1-0, ZELM, LMTH1-0, LMAT2-0, IPGL, IPGR, LRGA="1", GSEL)
- ② WR(LMTE="1", RCVE="0"): After the registers concerned in the auto limiter operation is set up and confirming the zero crossing flags(ZFIPL,ZFIPR)="1", LMTE is set "1".
- ③ As the input signal of ADC exceeds LMTH, the auto limiter operation starts.
- ④ WR(IPGA="31H"):As the auto limiter is in operation, writing by uP is ignored.
- ⑤ After the zero crossing operation of both Lch and Rch is completed, the next operation starts.
- ⑥ RD(LCDET&IPGA):Confirm to complete auto limiter operation and reads the IPGA present value.
- ⑦ WR(IPGA="2FH"):Update IPGA value.
- ⑧ WR(LMTE="0")
- ⑨ In Figure 7 , since "0" is written to LMTE during ATT operation, the operation changes to manual mode after completing ATT operation. After confirming LCDET="1", it is possible to change the each register set-up. If LMTE is set "0" during the auto limiter operation or the update of the IPGA value by uP, LCDET becomes "1" after the max "1" ATT/GAIN operation is completed by internal state.
- ⑩ In this case, the input signal of ADC exceeds LMTH, the auto limiter does not operate because of LMTE="0".

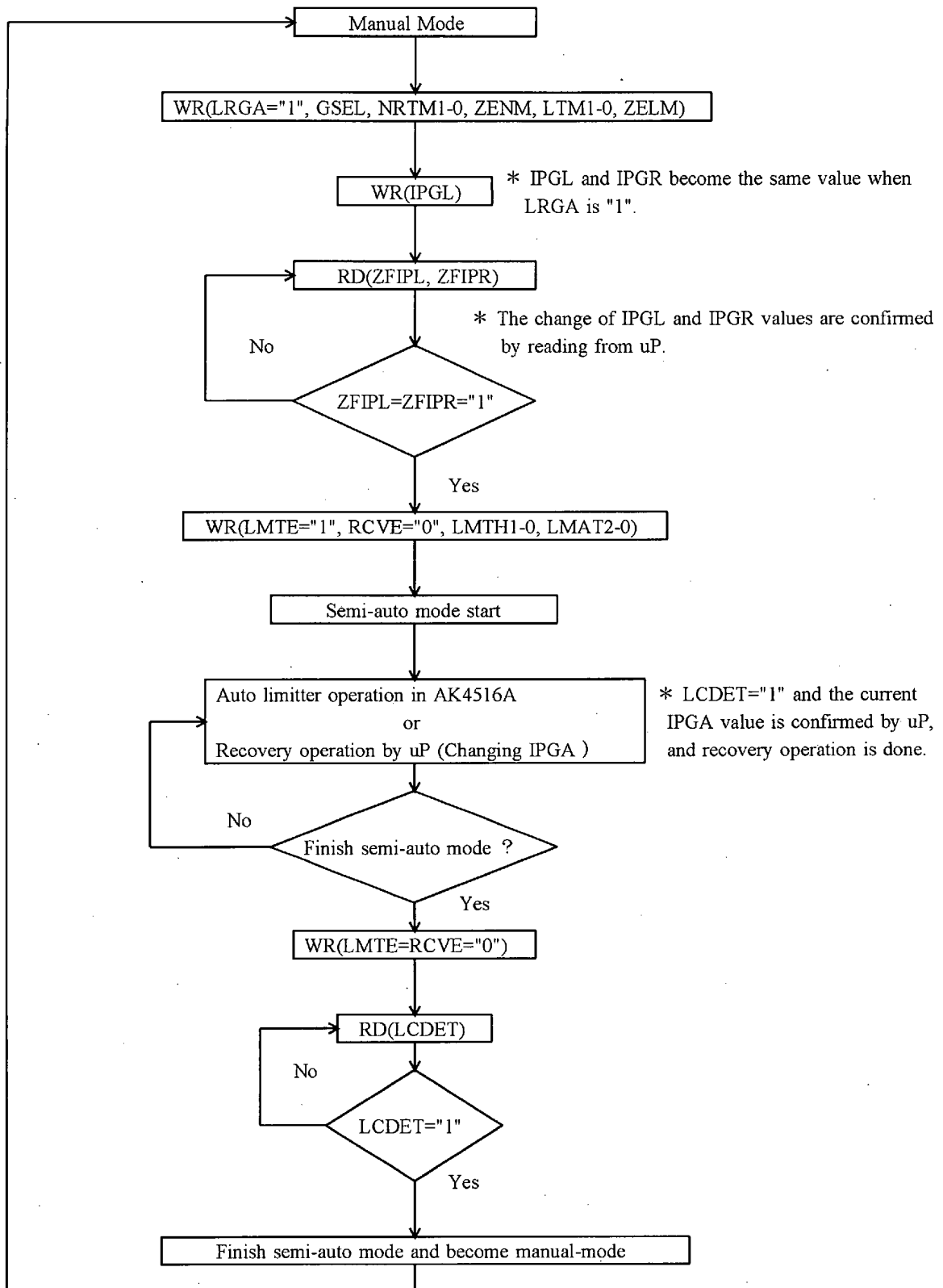

Figure 8 Register set-up sequence at Semi-auto mode

3. Full-auto Mode

The full-auto mode is done automatically by the auto limiter and the auto recovery function of the AK4516A. However, writing to the register is needed to enable these functions.

During the full-auto mode, writing to the following registers from uP is inhibited.

- LRGA, LTM1-0, ZELM, LMTH1-0, LMAT2-0, WTM1-0, NRTM1-0, RATT1-0, ZENM, REF6-0, IPGL, IPGR

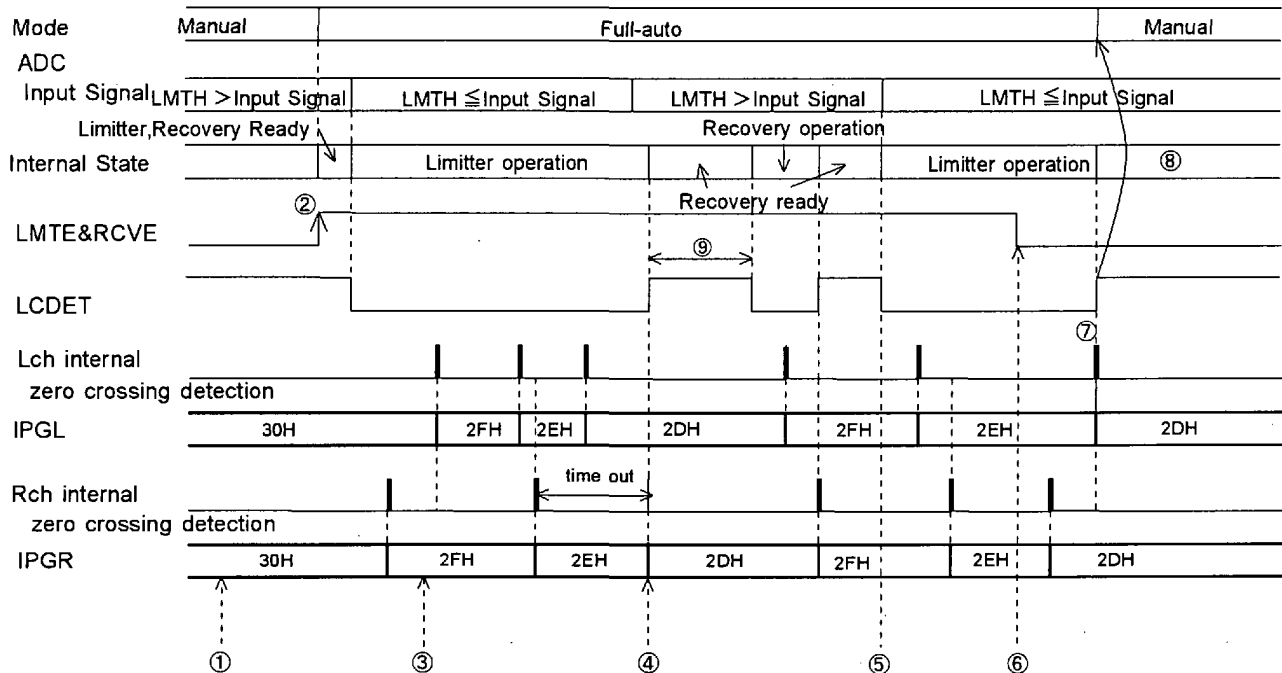

Figure 9 . Control example of full-auto mode operation (LMAT=RATT: 1 step, ZENM=ZELM="1")

- ① Set-up the registers of full-auto mode
(LTM1-0, ZELM, LMTH1-0, LMAT2-0, WTM1-0, RATT1-0, NRTM1-0, ZENM, REF6-0, GSEL, IPGL, IPGR, LRGA="1")
- ② WR(LMTE=RCVE="1"): After the registers concerned in the auto limiter operation is set up and confirming the zero crossing flags(ZFIPL, ZFIPR)="1", LMTH and RCVE are set "1".
- ③ WR(IPGA="31H"):As the operation is full-auto mode, writing by uP is ignored.
- ④ The ready of recovery starts.
- ⑤ As the input signal of ADC exceeds LMTH, the recovery operation (in the figure, recovery ready) is discontinued and the limiter operation starts.
- ⑥ WR(LMTE=RCVE="0"):The full-auto mode operation is completed.
- ⑦ In Figure 9 , since "0" is written to LMTE& RCVE during the ATT operation, the operation changes to the manual mode after completing ATT operation. After confirming LCDET="1", it is possible to change the each register set-up. If LMTE&RCVE are set "0" during the full-auto mode operation, LCDET becomes "1" after the max "1" ATT/GAIN operation is completed by internal state.
- ⑧ In this case, the input signal of ADC exceeds LMTH, the auto limiter does not operate because of LMTE=RCVE="0".
- ⑨ After the limiter operation is completed, the AK4516A waits for the time set by WTM1-0. If the input signal does not exceed (LMTH - 2dB), the recovery operation is executed. After the waiting time finishes the next waiting time starts immediately. In recovery ready, the waiting timer is reset under the condition of (LMTH - 2dB) ≤ Input Signal < LMTH. And the timer starts under the condition of (LMTH - 2dB) > Input Signal.

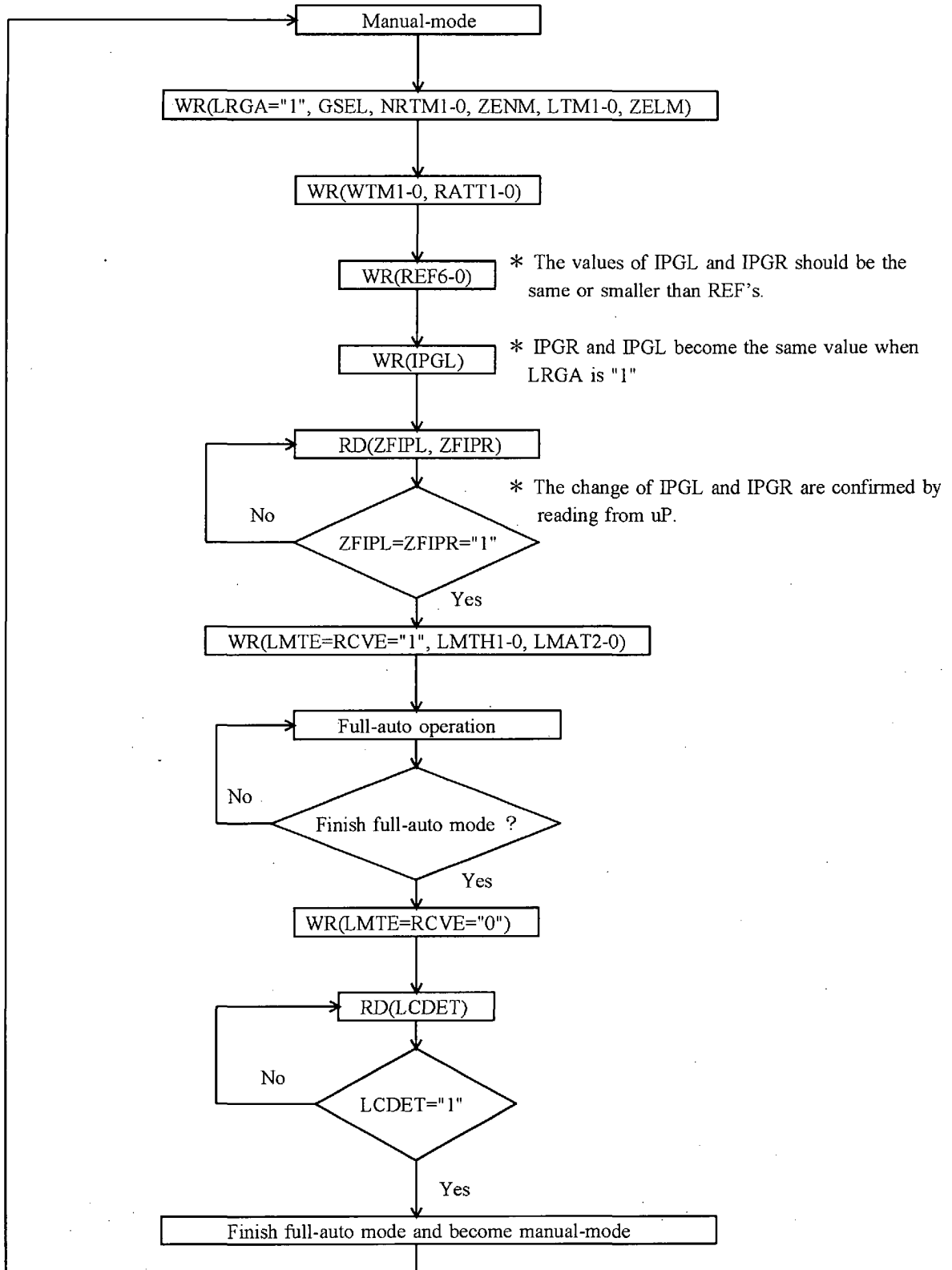

Figure 10 . Registers set-up sequence at Full-auto mode

Register Map

Addr	Register Name	D7	D6	D5	D4	D3	D2	D1	D0
00H	Input Select	0	0	0	0	RIN2	RIN1	LIN2	LIN1
01H	Mode Control 1	0	0	0	0	PM3	PM2	PM1	PM0
02H	Mode Control 2	MONO1	MONO0	DIF1	DIF0	FS1	FS0	DEM	0
03H	Zero Cross & Timer Control	LRGA	GSEL	NRTM1	NRTM0	ZENM	LTM1	LTM0	ZELM
04H	Peak Hold Low Byte Lch	PLL7	PLL6	PLL5	PLL4	PLL3	PLL2	PLL1	PLL0
05H	Peak Hold High Byte Lch	PUL7	PUL6	PUL5	PUL4	PUL3	PUL2	PUL1	PUL0
06H	Peak Hold Low Byte Rch	PLR7	PLR6	PLR5	PLR4	PLR3	PLR2	PLR1	PLR0
07H	Peak Hold High Byte Rch	PUR7	PUR6	PUR5	PUR4	PUR3	UR2	PUR1	PUR0
08H	Overflow Status	ZFIPR	ZFIPL	ROF2	ROF1	ROF0	LOF2	LOF1	LOF0
09H	Auto LMT&RCV Control	LMTE	RCVE	0	LMTH1	LMTH0	LMAT2	LMAT1	LMAT0
0AH	Input PGA Control Lch	LCDET	IPGL6	IPGL5	IPGL4	IPGL3	IPGL2	IPGL1	IPGL0
0BH	Input PGA Control Rch	LCDET	IPGR6	IPGR5	IPGR4	IPGR3	IPGR2	IPGR1	IPGR0
0CH	Auto Recovery Control 1	0	0	0	0	WTM1	WTM0	RATT1	RATT0
0DH	Auto Recovery Control 2	0	REF6	REF5	REF4	REF3	REF2	REF1	REF0

Table 2 . AK4516A Register Map

Input Select

Addr	Register Name	D7	D6	D5	D4	D3	D2	D1	D0
00H	Input Select	0	0	0	0	RIN2	RIN1	LIN2	LIN1
	R/W	R/W							
	RESET	0	0	0	0	0	1	0	1

LIN2-1 : Select ON/OFF of Lch input (0:OFF, 1:ON). These bits can select to ON/OFF at the same time.

RIN2-1 : Select ON/OFF of Rch input (0:OFF, 1:ON). These bits can select to ON/OFF at the same time.

This register is reset at $\overline{\text{PD}}$ pin="L", then inhibits writing to this register.

Mode Control 1

Addr	Register Name	D7	D6	D5	D4	D3	D2	D1	D0
01H	Mode Control 1	0	0	0	0	PM3	PM2	PM1	PM0
	R/W	R/W							
	RESET	0	0	0	0	0	1	1	1

PM3-0: Power Management (0: Power Down, 1:Power Up)

PM0: Mixer, PGA input, Auto Limiter and Auto Recovery power control.

PM1: Power control of ADC

PM2: Power control of DAC

PM3: Used both as power control of analog loopback circuit and as selection of MUX.

(0: DAC, 1:Analog loopback)

PM0-3 can be partially powered-down by ON/OFF of PM0-3. When \overline{PD} pin goes "L", all the circuit in AK4516A can be powered-down regardless of PM0-3.

When PM0-3 go all "0", all the circuits in AK4516A can be also powered-down.

When PM3 goes "1", input for output-AMP is selected to analog loopback circuit from DAC output.

Output MUX and AMP are powered-down when \overline{PD} ="L" or PM2=PM3="0". Refer to Figure 11 .

The loopback output and the MUX selecting DAC output is a MIXER with the switch in practice. Therefore, when both PM2 and PM3 select ON, the analog loopback signal and DAC output are mixed by Gain 1.

Except the case of PM0=PM1=PM2=PM3="0" or \overline{PD} pin="L", MCLK, BCLK, LRCK should not be stopped.

When the input PGA and MUX are powered-down by PM0-3 or \overline{PD} pin, the output of AMP becomes Hi-Z(floating).

This register is reset by the \overline{PD} pin="L", then inhibits writing to this register.

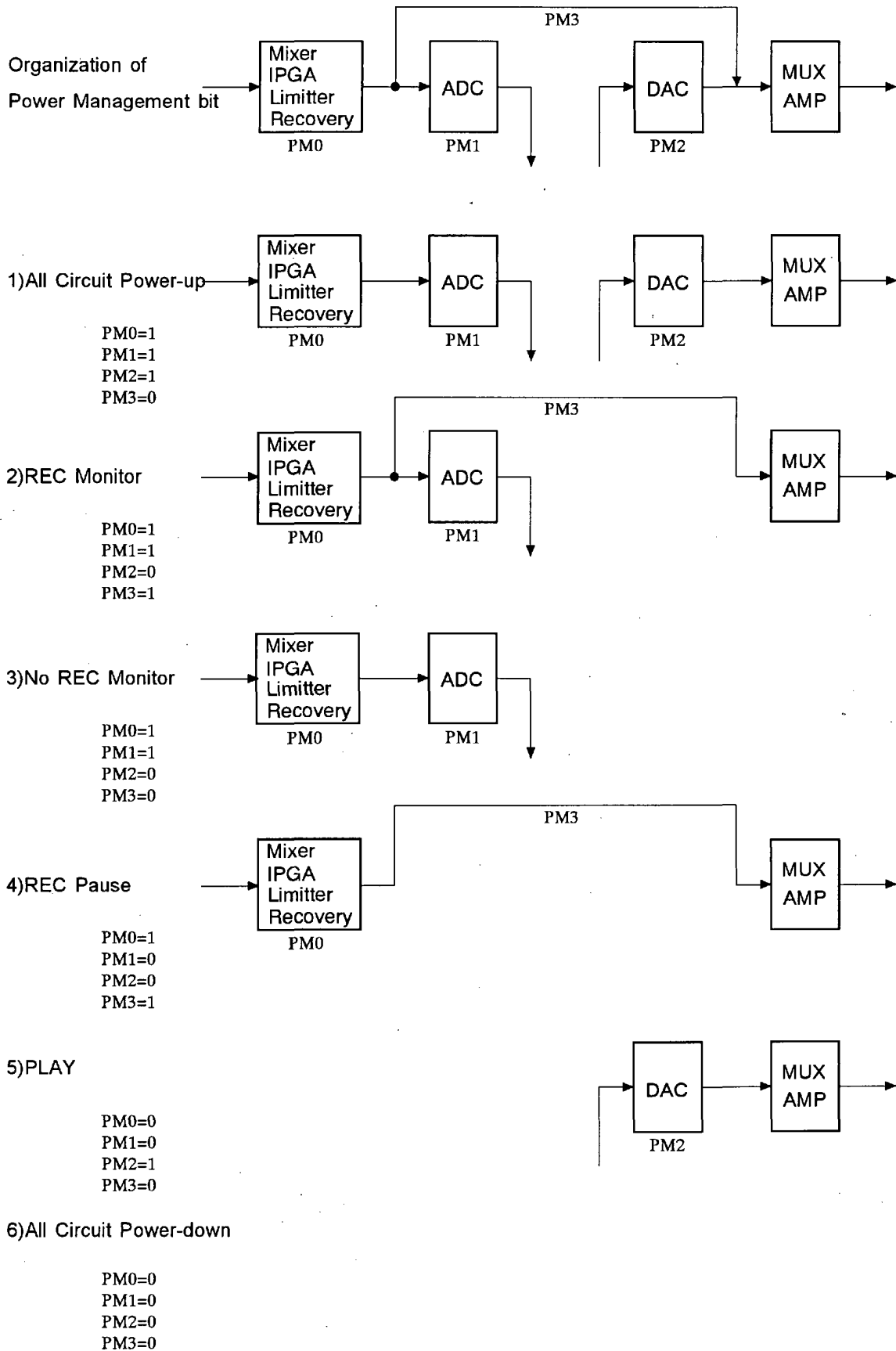

Figure 11 . Power Management

Mode Control 2

Addr	Register Name	D7	D6	D5	D4	D3	D2	D1	D0
02H	Mode Control 2	MONO1	MONO0	DIF1	DIF0	FS1	FS0	DEM	0
	R/W	R/W	R/W	R/W	R/W	R/W	R/W	R/W	RD
	RESET	0	0	0	0	0	0	0	0

MONO1-0: Monaural Mixing

- 00: Stereo (RESET)
- 01: (L+R)/2
- 10: LL
- 11: RR

DIF1-0: Select Audio Serial Interface Format

The data is all 2's complement, MSB first.

No.	DIF1	DIF0	SDTO(ADC)	SDTI(DAC)	BCLK	Figure
0	0	0	MSB justified	LSB justified	≥32fs	Figure 1
1	0	1	LSB justified	LSB justified	= 64fs	Figure 2
2	1	0	MSB justified	MSB justified	≥32fs	Figure 3
3	1	1	I ² S compatible	I ² S compatible	≥32fs	Figure 4

RESET

Table 3 . Audio Serial Interface Format

FS1-0: Select De-emphasis frequency

The AK4516A includes the digital de-emphasis filter(tc=50/15us) by IIR filter. The filter corresponds to three sampling frequency (32kHz, 44.1kHz, 48kHz). The de-emphasis filter selected by FS0 and FS1 registers are enabled for input audio data.

FS1	FS0	Mode
0	0	44.1kHz
0	1	OFF
1	0	48kHz
1	1	32kHz

RESET

Table 4 . De-emphasis frequency

DEM: Control of De-emphasis (0: Disable, 1: Enable)

FS0 and FS1 registers of the de-emphasis are enabled by setting DEM=1. FS0 and FS1 are ignored at DEM=0.

This register is reset by the $\overline{\text{PD}}$ pin="L", then inhibits writing to this register.

Zero Cross & Timer Control

Addr	Register Name	D7	D6	D5	D4	D3	D2	D1	D0
03H	Zero Cross & Timer Control	LRGA	GSEL	NRTM1	NRTM0	ZENM	LTM1	LTM0	ZELM
	R/W	R/W	R/W	R/W	R/W	R/W	R/W	R/W	R/W
	RESET	1	1	1	0	0	1	0	0

LRGA: Selects the method of writing to IPGA

0: Independent data can be written to IPGA and IPGR.

1: Common data can be written to IPGL and IPGR.

In this case, when a data is written to IPGL, the same data is also written to IPGR. When a data is written to IPGR, a data is only written to IPGR. When IPGL value differs from IPGR value, IPGL and IPGR values can be set by a common data after writing IPGL value at LRGA="1". (RESET)

GSEL: Selects input gain (set a common Lch and Rch)

0: LINE

1: MIC (RESET)

Even if LINE and MIC are the same data value, both gain values are different.

NRTM1-0: Zero crossing timeout at writing operation by uP and auto recovery operation.

Set-up zero crossing timeout at writing operation by uP and the auto recovery operation. The writing operation by uP and the auto recovery operation set up in common. In case of the auto limiter operation, zero crossing operation is set by different bits(LTM1-0).

NRTM1	NRTM0	Zero crossing timeout(ZENM="1")			
		48kHz	44.1kHz	32kHz	
0	0	513/fs	10.7ms	11.6ms	16.0ms
0	1	1025/fs	21.4ms	23.2ms	32.0ms
1	0	2049/fs	42.7ms	46.5ms	64.0ms
1	1	4097/fs	85.4ms	92.9ms	128.0ms

RESET

Table 5 . Zero crossing timeout at uP writing operation and auto recovery operation.
(NRTM1="1", NRTM0="0" at RESET)

ZENM: Enables zero crossing detection at uP WRITE operation or auto recovery operation

(0: Disable, 1: Enable)

1: When IPGA of each L/R channels do zero crossing or timeout independently, the IPGA value is changed by uP WRITE operation or auto recovery operation.

0: IPGA is changed immediately.

LTM1-0:Zero crossing timeout(ZELM="1") or Update period(ZELM="0") at the auto limiter mode
(LTM1="1", LTM0="0"@RESET)

LTM1	LTM0	Zero crossing timeout(ZELM="1")				Update period(ZELM="0")			
		48kHz	44.1kHz	32kHz		48kHz	44.1kHz	32kHz	
0	0	129/fs	2.7ms	2.9ms	4.0ms	1/fs	21us	23us	31us
0	1	258/fs	5.4ms	5.9ms	8.1ms	2/fs	42us	45us	63us
1	0	516/fs	10.8ms	11.7ms	16.1ms	4/fs	83us	91us	125us
1	1	1032/fs	21.5ms	23.4ms	32.3ms	8/fs	167us	181us	250us

Table 6 . Zero crossing timeout or Update period at the auto limiter mode

ZELM: Enables zero crossing detection at the auto limiter operation (0: Disable, 1: Enable)

0: The IPGA value is changed immediately. When the IPGA value is changed continuously, the change is done by the period specified by LTM1-0.

1: When IPGA of each L/R channel do zero crossing or timeout independently, the IPGA value is changed by auto limiter operation.

These bits are reset by $\overline{\text{PD}}$ pin="L", then inhibits writing to these bits.

Peak Hold

Addr	Register Name	D7	D6	D5	D4	D3	D2	D1	D0
04H	Peak Hold Low Byte Lch	PLL7	PLL6	PLL5	PLL4	PLL3	PLL2	PLL1	PLL0
05H	Peak Hold High Byte Lch	PUL7	PUL6	PUL5	PUL4	PUL3	PUL2	PUL1	PUL0
06H	Peak Hold Low Byte Rch	PLR7	PLR6	PLR5	PLR4	PLR3	PLR2	PLR1	PLR0
07H	Peak Hold High Byte Rch	PUR7	PUR6	PUR5	PUR4	PUR3	PUR2	PUR1	PUR0
R/W		RD							
RESET		00H							

PLL7-0: Peak hold of Lch (Absolute value), 8bit of LSB (FFH~00H)

PUL7-0: Peak hold of Lch (Absolute value), 8bit of MSB (7FH~00H)

PLR7-0: Peak hold of Rch (Absolute value), 8bit of LSB (FFH~00H)

PUR7-0: Peak hold of Rch (Absolute value), 8bit of MSB (7FH~00H)

The peak is held L/R audio data independently. These registers are reset by reading 8bit of MSB, reading 8bit of both MSB and LSB should be continuity controlled by reading in order of 8 bit of MSB from LSB. After reading the 8 bit of LSB the last, 8 bit of MSB is lost by reading 8 bit of LSB the last. Sign bits (PUL7, PUR7) becomes "0" as the output value is the absolute value.

These registers are reset on the following any conditions.

- $\overline{\text{PD}}$ pin="L"
- PM1="0"

Overflow Status

Addr	Register Name	D7	D6	D5	D4	D3	D2	D1	D0
08H	Overflow Status	ZFIPR	ZFIPL	ROF2	ROF1	ROF0	LOF2	LOF1	LOF0
	R/W	RD	RD	RD	RD	RD	RD	RD	RD
	RESET	0	0	0	0	0	0	0	0

ZFIPR: Rch IPGA zero crossing detection flag.

ZFIPL: Lch IPGA zero crossing detection flag.

At writing operation by uP, when ZENM is "1", this flag becomes "0" if IPGA value is set independently for L/R. When each channel does zero crossing or timeout, and then IPGA of each channel is changed, the flag of each channel becomes "1".

When writing to the same channel is done again under zero crossing waiting before this flag becomes "1", the timeout counter is not reset. Therefore then, zero crossing timeout period becomes shorter for the new writing. But if writing is done to the channel which the flag is "1" when the flag of either Lch or Rch is "0", the timeout counter is reset. In this case, zero crossing timeout counter restarts from the last writing.

When ZEIP is "0", ZFIPL/ZFIPR always become "1". ZFIPL/ZFIPR always become "1" during semi-auto mode operation (LMTE="1", RCVE="0") and full-auto mode operation (LMTE=RCVE="1").

ZFIPR/ZFIRL is "0" during initializing operation after exiting power-down by \overline{PD} pin. The completion of the initializing operation can be recognized by confirming these flags are "1".

These bits are reset on the following any conditions.

- \overline{PD} pin="L"

In case of PM0="0", these flag become "1".

ROF2-0: Overflow Flag of Rch

Overflow flag includes 3 bit. Max value of the overflow is held. These bits are reset to (0, 0, 0) by reading by uP.

These bits are reset on the following any conditions.

- \overline{PD} pin="L"
- PM1="0"

ROF2	ROF1	ROF0	Threshold
0	0	0	<-12.04dB
0	0	1	-12.04dB≤
0	1	0	-8.52dB≤
0	1	1	-6.02dB≤
1	0	0	-4.08dB≤
1	0	1	-1.80dB≤
1	1	0	-0.00dB≤

Table 7 . Overflow Flag of Rch

LOF2-0: Overflow Flag of Lch

Overflow flag includes 3bit. Max value of overflow is held. These bits are reset to (0, 0, 0) by reading by uP.

These bits are reset on the following any conditions.

- \overline{PD} pin="L"
- PM1="0"

LOF2	LOF1	LOF0	Threshold
0	0	0	<-12.04dB
0	0	1	-12.04dB≤
0	1	0	-8.52dB≤
0	1	1	-6.02dB≤
1	0	0	-4.08dB≤
1	0	1	-1.80dB≤
1	1	0	-0.00dB≤

Table 8 . Overflow Flag of Lch

Auto Limitter Control

During the auto limiter operation, when either Lch or Rch exceed auto limiter detection level (LMTH1-0), IPGA value is attenuated by auto limiter ATT step (LMAT1-0) automatically. Then the IPGA value is changed commonly for L/R channels. In this operation, either zero crossing detection with timeout or immediate change is selected by ZELM. Timeout period and update period are set by LTM1-0 (refer to Table 6). The operation for attenuation is done continuously until the input signal level becomes LMTH1-0 or less. Unless LMTE is set "1" after finishing operation for attenuation, this operation for attenuation repeats when input signal level exceeds LMTH1-0 again. IPGA value of register is always written to current value in this mode automatically, the operation for attenuation always starts from current IPGA value.

When the operation for attenuation is completed after the input signal becomes LMTH1-0 or less, auto limiter detection flag(LCDET) becomes "1". This flag become "0" when the input signal exceeds LMTH1-0 again and the AK4516A enters the auto limiter operation.

During the auto limiter operation (LCDET=0), IPGA is changed according to the value set by the auto limiter operation. Therefore, uP writing operation is ignored.

During semi-auto mode and after completing auto limiter operation(LCDET="1"), IPGA is changed according to the value written by uP.

Addr	Register Name	D7	D6	D5	D4	D3	D2	D1	D0
09H	Auto LMT&RCV Control	LMTE	RCV	0	LMTH1	LMTH0	LMAT2	LMAT1	LMAT0
	R/W	R/W	R/W	RD	R/W	R/W	R/W	R/W	R/W
	RESET	0	0	0	1	1	0	0	0

LMTE: Auto Limitter Enable Flag

0: Auto limiter operation OFF (RESET)

1: Auto limiter operation ON

RCVE: Auto Recovery Enable Flag

0: Auto recovery operation OFF(RESET)

1: Auto recovery operation ON.

This bit is only available at LMTE="1". When LMTE is "0" , auto recovery operation becomes "OFF".

The change of operation mode by LMTE and RCVE bits always needs to control via manual-mode, between the semi-auto mode and the full-auto mode should not be changed.

IPGA value of each channel should be equal value before entering the semi-auto mode and the full-auto mode. LRGA should be set "1" during the semi-auto mode and writing operation by uP should always write equal value to each channel.

LMTH1-0:Auto Limitter Detection Level / Auto Recovery Waiting Counter Reset Level

LMTH1	LMTH0	Auto Limitter Detection Level	Auto Recovery Waiting Counter Reset Level
0	0	ADC Input \geq -8.0dB	-8.0dB>ADC Input \geq -10.0dB
0	1	ADC Input \geq -6.0dB	-6.0dB>ADC Input \geq -8.0dB
1	0	ADC Input \geq -4.0dB	-4.0dB>ADC Input \geq -6.0dB
1	1	ADC Input \geq -2.0dB	-2.0dB>ADC Input \geq -4.0dB

Table 9 . Auto Limitter Detection Level / Auto Recovery waiting Counter Reset Level

(LMTJ1=LMTH0="0" @RESET)

LMAT2-0: Auto Limiter ATT Step

During the auto limiter operation, when either Lch or Rch exceeds the auto limiter detection level set by LMTH1-0, the number of steps attenuated from current IPGA value is set. For example, when the current IPGA value is 68H in the state of LMAT2-0="111", it becomes IPGA=60H by the auto limiter operation, the input signal level is attenuated by 4dB (=0.5dB x 8).
 Auto limiter operation period is the constant period by setting LTM1-0 at ZELM="1", it is the different period by the input signal at ZELM="0". (depend on zero crossing detection period)
 When the attenuation value exceeds IPGA="00"(MUTE), it clips to "00".

LMAT2	LMAT1	LMAT0	ATT STEP
0	0	0	1
0	0	1	2
0	1	0	3
0	1	1	4
1	0	0	5
1	0	1	6
1	1	0	7
1	1	1	8

RESET

Table 10 . Auto Limiter ATT Step Setting

These bits are reset by $\overline{\text{PD}}$ pin="L", then inhibits writing to these bits.

Input Analog PGA Control

Addr	Register Name	D7	D6	D5	D4	D3	D2	D1	D0
0AH	Input PGA Control Lch	LCDET	IPGL6	IPGL5	IPGL4	IPGL3	IPGL2	IPGL1	IPGL0
0BH	Input PGA Control Rch	LCDET	IPGR6	IPGR5	IPGR4	IPGR3	IPGR2	IPGR1	IPGR0
	R/W	RD				R/W			
	RESET	1				30H			

LCDET: Auto Limiter and Auto Recovery detection Flag(refer to Figure 7 and Figure 9)

0: Updating IPGA value by uP writing at the semi-auto mode and the auto limiter or the auto recovery operation.

1: Complete the auto recovery operation or the auto limiter operation. Complete updating IPGA value by uP writing at semi-auto mode. (RESET)

This flag(LCDET) always become "1" at manual mode(LMTE=RCVE="1"). The LCDET in 0AH and 0BH shows the same value.

This flag is "0" during initialization after exiting power-down mode by $\overline{\text{PD}}$ pin.

During the semi-auto mode operation, if LMTE is set "0" during the auto limiter operation or the update of the IPGA value by uP, LCDET becomes "1" after the max "1" ATT/GAIN operation is completed by internal state.

During the full-auto-mode operation, if LMTE&RCVE are set "0" during the full-auto mode operation, LCDET becomes "1" after the max "1" ATT/GAIN operation is completed by internal state.

In case of changing the registers relative to the semi-auto mode and the full-auto mode, these registers should be changed after writing LMTE="0"(at the semi-auto mode) or LMTE=RCVE="0" (at the full-auto mode) and then confirming LCDET="1".

IPGL6-0: Lch Input Analog PGA. 105 levels.

IPGR6-0: Rch Input Analog PGA. 105 levels.

ON/OFF of zero crossing detection is controlled by ZENM/ZELM bits.

RESET

DATA	GAIN(dB)		STEP	LEVEL
	MIC	LINE		
68H	+28.0	+8.0	0.5dB	73
67H	+27.5	+7.5		
66H	+27.0	+7.0		
:	:	:		
30H	0.0	-20.0		
2FH	-0.5	-20.5		
:	:	:		
21H	-7.5	-27.5	1dB	24
20H	-8.0	-28.0		
1FH	-9.0	-29.0		
1EH	-10.0	-30.0		
:	:	:		
09H	-31.0	-51.0	2dB	4
08H	-32.0	-52.0		
07H	-34.0	-54.0		
06H	-36.0	-56.0		
05H	-38.0	-58.0	4dB	3
04H	-40.0	-60.0		
03H	-44.0	-64.0		
02H	-48.0	-68.0	4dB	3
01H	-52.0	-72.0		
00H	MUTE	MUTE		1

Table 11 . Input Gain Setting

IPGL and IPGR are read by uP current values at rising of \overline{CS} pin.

These registers are reset by \overline{PD} pin="L", then inhibits writing to these registers.

These registers are reset by PM0="0".

Auto Recovery Control

Auto recovery operation starts after completing auto limiter operation (LCDET="1") at LMTE=RCVE="1". IPGA gain increases automatically by this operation up to the set reference level(REF6-0). Then the IPGA value is set for L/R commonly. Either zero crossing or fs(sampling frequency) period for this auto recovery operation is decided by zero crossing detection at the auto recovery operation and the writing operation by uP (=ZENM).

During the auto recovery operation, when either input signal level of Lch or Rch exceeds the auto limiter detection level (LMTH1-0), the auto recovery operation changes into the auto limiter operation immediately. (Refer to Figure 9)

Addr	Register Name	D7	D6	D5	D4	D3	D2	D1	D0
0CH	Auto Recovery Control 1	0	0	0	0	WTM1	WTM0	RATT1	RATT0
	R/W	RD	RD	RD	RD	R/W	R/W	R/W	R/W
	RESET	0	0	0	0	1	0	0	0

WTM1-0: Auto Recovery Waiting Time

Recovery operation is done at a period set by WTM1-0 when any limiter operation does not occur at full-auto mode. When the input signal level exceeds auto recovery waiting counter reset level set by LMTH1-0, the auto recovery waiting counter is reset.

The waiting timer starts when the input signal level becomes below the auto recovery waiting counter reset level.

When the auto recovery waiting time(WTM1-0) is shorter than zero crossing timeout period of the auto recovery operation(NRTM1-0), the auto recovery is operated by NRTM1-0.

Therefore, in this case the auto recovery operation period is not constant.

WTM1	WTM0	Timeout			RESET
		48kHz	44.1kHz	32kHz	
0	0	512/fs	10.7ms	11.6ms	16.0ms
0	1	1024/fs	21.3ms	23.2ms	32.0ms
1	0	2048/fs	42.6ms	46.4ms	64.0ms
1	1	4096/fs	85.2ms	92.8ms	128.0ms

Table 12 . Auto Recovery Operation Waiting Period

RATT1-0: Auto Recovery GAIN Step

During the auto recovery operation, the number of steps changed from current IPGA value is set. For example, when the current IPGA value is 30H, RATT1="0", RATT0="1" are set, IPGA changes to 32H by the auto limiter operation, the input signal level is gained by 1dB(=0.5dB x 2).

The auto recovery operation period is fs period at ZENM="0", the auto recovery operation is done after zero crossing detection or timeout in case of ZENM="1"

When the IPGA value exceeds the reference level (REF6-0), the IPGA value does not increase.

RATT1	RATT0	GAIN STEP	RESET
0	0	1	
0	1	2	
1	0	3	
1	1	4	

Table 13 . Auto Recovery GAIN Step Setting

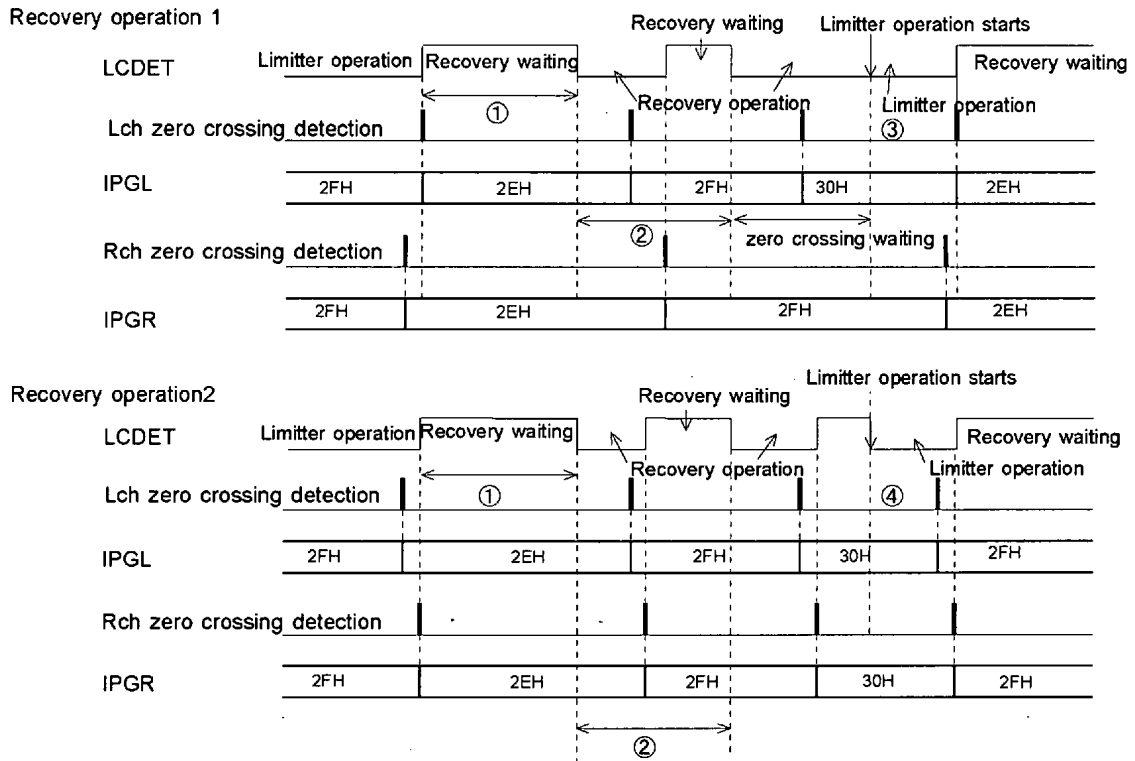

Figure 12 . Auto Recovery Operation (LMAT=RATT = 1 Step, ZENM=ZELM="1")

- ① After completing the auto limiter operation, the auto recovery operation wait for only a period set by WTM1-0. If the auto limiter operation is not occurred during the recovery operation, the auto recovery operation is done only once.
- ② IPGA is changed by zero crossing in the auto recovery operation, and the count of the next recovery waiting period is also proceeding at the same time.
- ③ When the auto limiter operation is entered in zero crossing waiting(Rch), the auto recovery operation in progress is stopped, the auto limiter is done according to smaller value (Rch in the Figure 10) of the IPGA value. Then, IPGL is changed from 30H to 2EH and IPGR is changed from 2FH to 2EH. (refer to Recovery Operation 1)
- ④ When the auto recovery operation is waiting for the next operation, the limiter operation is done from IPGA value at that time . (refer to Recovery Operation 2)

This register is reset by $\overline{\text{PD}}$ pin = "L", then inhibits writing to this register.

Addr	Register Name	D7	D6	D5	D4	D3	D2	D1	D0
0DH	Auto Recovery Control 2	0	REF6	REF5	REF4	REF3	REF2	REF1	REF0
	R/W	RD	R/W	R/W	R/W	R/W	R/W	R/W	R/W
	RESET	0	0	1	1	0	0	0	0

REF6-0: Set the Reference value at Auto Recovery Operation

During the auto recovery operation, when IPGA value becomes the reference value set by REF6-0, the gain of the auto recovery operation does not exceed the reference value. The reference value is set commonly as for Lch and Rch.

During the auto recovery operation, if IPGA value exceeds the setting reference value by GAIN operation, IPGA does not become the larger than the reference value.

For example, when REF=30H, RATT=2 step, IPGA=2FH, IPGA will become 2FH + 2step = 31H by auto recovery operation, but IPGA value becomes 30H as REF value is 30H.

IPGA should be certainly set to the same value or smaller than REF value before entering full-auto mode .

RESET

DATA	GAIN(dB)		STEP	LEVEL
	MIC	LINE		
68H	+28.0	+8.0	0.5dB	73
67H	+27.5	+7.5		
66H	+27.0	+7.0		
:	:	:		
30H	0.0	-20.0		
2FH	-0.5	-20.5		
:	:	:		
21H	-7.5	-27.5	1dB	24
20H	-8.0	-28.0		
1FH	-9.0	-29.0		
1EH	-10.0	-30.0		
:	:	:		
09H	-31.0	-51.0	2dB	4
08H	-32.0	-52.0		
07H	-34.0	-54.0		
06H	-36.0	-56.0		
05H	-38.0	-58.0	4dB	3
04H	-40.0	-60.0		
03H	-44.0	-64.0		
02H	-48.0	-68.0	4dB	3
01H	-52.0	-72.0		
00H	MUTE	MUTE		1

Table 14 . Reference Value Setting in Auto Recovery operation

These bits are reset by $\overline{\text{PD}}$ pin ="L", then inhibits writing to these bits.

SYSTEM DESIGN

Figure 13 shows the system connection example. An evaluation board [AKD4516A] is available which demonstrates the optimum layout, power supply arrangement and measurement results.

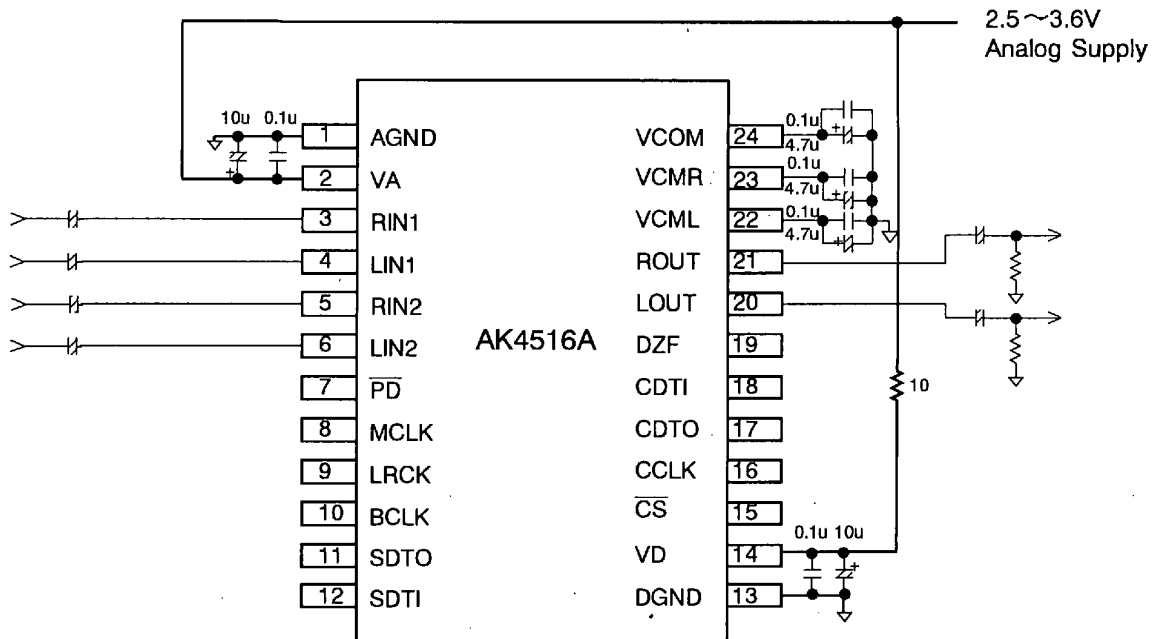

Figure 13 . Typical Connection Diagram

NOTE:

- LRCK=fs, SCLK ≥ 32fs or 64fs, MCLK=256fs or 384fs
- Power supply lines of VA and VD should be distributed separately from the point with low impedance of regulator or connecting to the resistor of 10 ohms.
- When LOUT(ROUT) drives some capacitive load, some resistor should be added in series between LOUT(ROUT) and capacitive load.
- The capacitor value on VCOM depends on low frequency noise level of power supply.

1. Grounding and Power Supply Decoupling

The AK4516A requires careful attention to power supply and grounding arrangements. When VA and VD are supplied separately, VA should not be the higher voltage than VD. If so not, VA is supplied from analog supply in system and VD is supplied from VA via 10 ohms resistor.(refer to Figure 13)

System analog ground and digital ground should be connected together near to where the supplies are brought onto the printed circuit board. Decoupling capacitors should be as near to the AK4516A as possible, with the small value ceramic capacitor being nearest.

2. Voltage Reference

VCOM is a signal ground of this chip. An electrolytic less than 4.7uF in parallel with a 0.1uF ceramic capacitor attached to these pins eliminates the effects of high frequency noise. No load current maybe drawn from VCOM pin. All signals, especially clock, should be kept away from the VA, VCML, VCMR, VCOM pins in order to avoid unwanted coupling into the AK4516A.

3. Analog Inputs

ADC inputs are single-ended and internally biased to VCML & VCMR with 50k Ω (typ). The input signal range scales with the supply voltage and nominally 0.57 x VA Vpp(typ). The ADC output data format is 2's compliment. The output code is 7FFFH(@16bit) for input above a positive full scale and 8000H(@16bit) for input below a negative full scale. Ideal code is 0000H(@16bit) with no input signal.

4. Analog Outputs

The analog outputs are also single-ended and centered around the VCOM voltage. The input signal range scales with the supply voltage and nominally 0.6 x VA Vpp(typ). The DAC input data format is 2's compliment. The output voltage is a positive full scale for 7FFFH(@16bit) and a negative full scale for 8000H(@16bit). The ideal output is VCOM voltage for 0000H(@16bit). If the noise generated by the delta-sigma modulator beyond the audio band would be the problem, the attenuation by external filter is required.

PACKAGE

● 24pin VSOP (Unit: mm)

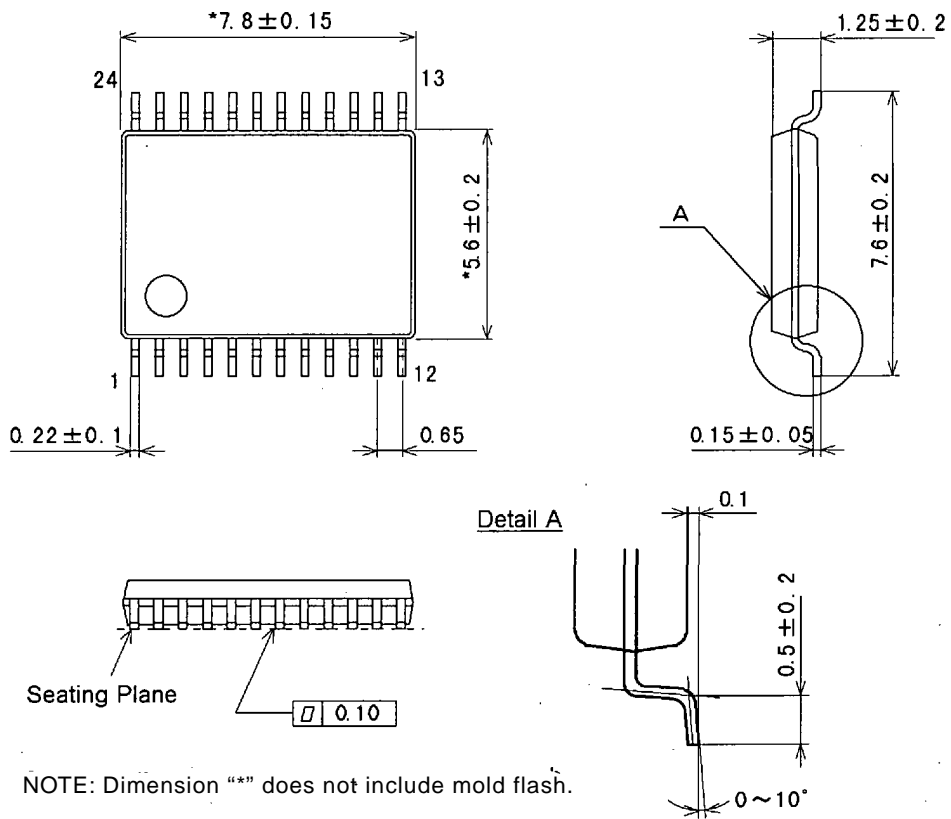

NOTE: Dimension "*" does not include mold flash.

■ Material & Lead finish

Package molding compound:	Epoxy
Lead frame material:	Cu
Lead frame surface treatment:	Solder plate

MARKING

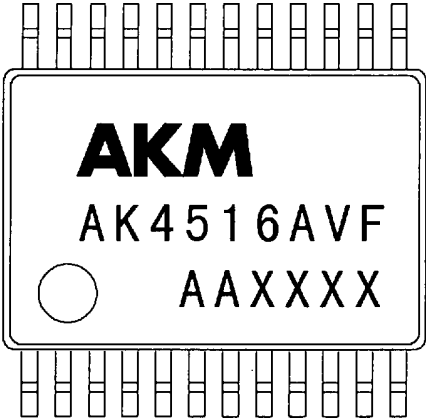

Contents of AAXXXX

AA: Lot#

XXXX: Date Code

IMPORTANT NOTICE

- These products and their specifications are subject to change without notice. Before considering any use or application, consult the Asahi Kasei Microsystems Co., Ltd. (AKM) sales office or authorized distributor concerning their current status.
- AKM assumes no liability for infringement of any patent, intellectual property, or other right in the application or use of any information contained herein.
- Any export of these products, or devices or systems containing them, may require an export license or other official approval under the law and regulations of the country of export pertaining to customs and tariffs, currency exchange, or strategic materials.
- AKM products are neither intended nor authorized for use as critical components in any safety, life support, or other hazard related device or system, and AKM assumes no responsibility relating to any such use, except with the express written consent of the Representative Director of AKM. As used here:
 - (a) A hazard related device or system is one designed or intended for life support or maintenance of safety or for applications in medicine, aerospace, nuclear energy, or other fields, in which its failure to function or perform may reasonably be expected to result in loss of life or in significant injury or damage to person or property.
 - (b) A critical component is one whose failure to function or perform may reasonably be expected to result, whether directly or indirectly, in the loss of the safety or effectiveness of the device or system containing it, and which must therefore meet very high standards of performance and reliability.
- It is the responsibility of the buyer or distributor of an AKM product who distributes, disposes of, or otherwise places the product with a third party to notify that party in advance of the above content and conditions, and the buyer or distributor agrees to assume any and all responsibility and liability for and hold AKM harmless from any and all claims arising from the use of said product in the absence of such notification.