



QUAD/DUAL N-CANNEL MATCHED MOSFET ARRAY

GENERAL DESCRIPTION

The ALD1106/ALD1116 are monolithic quad/dual N-channel enhancement mode matched MOSFET transistor arrays intended for a broad range of precision analog applications. The ALD1106/ALD1116 offer high input impedance and negative current temperature coefficient. The transistor pairs are matched for minimum offset voltage and differential thermal response, and they are designed for switching and amplifying applications in +2V to +12V systems where low input bias current, low input capacitance and fast switching speed are desired. These MOSFET devices feature very large (almost infinite) current gain in a low frequency, or near DC, operating environment. The ALD1106/ALD1116 are building blocks for differential amplifier input stages, transmission gates, and multiplexer applications, current sources and many precision analog circuits.

FEATURES

- Low threshold voltage of 0.7V
- Low input capacitance
- Low Vos 2mV typical
- High input impedance -- 10¹⁴Ω typical
- Negative current (I_{DS}) temperature coefficient
- Enhancement-mode (normally off)
- DC current gain 10⁹
- Low input and output leakage currents

ORDERING INFORMATION

Operating Temperature Range*		
-55°C to +125°C	0°C to +70°C	0°C to +70°C
8-Pin CERDIP Package	8-Pin Plastic Dip Package	8-Pin SOIC Package
ALD1116 DA	ALD1116 PA	ALD1116 SA
14-Pin CERDIP Package	14-Pin Plastic Dip Package	14-Pin SOIC Package
ALD1106 DB	ALD1106 PB	ALD1106 SB

* Contact factory for industrial temperature range.

APPLICATIONS

- Precision current mirrors
- Precision current sources
- Voltage choppers
- Differential amplifier input stage
- Voltage comparator
- Data converters
- Sample and Hold
- Analog signal processing

PIN CONFIGURATION

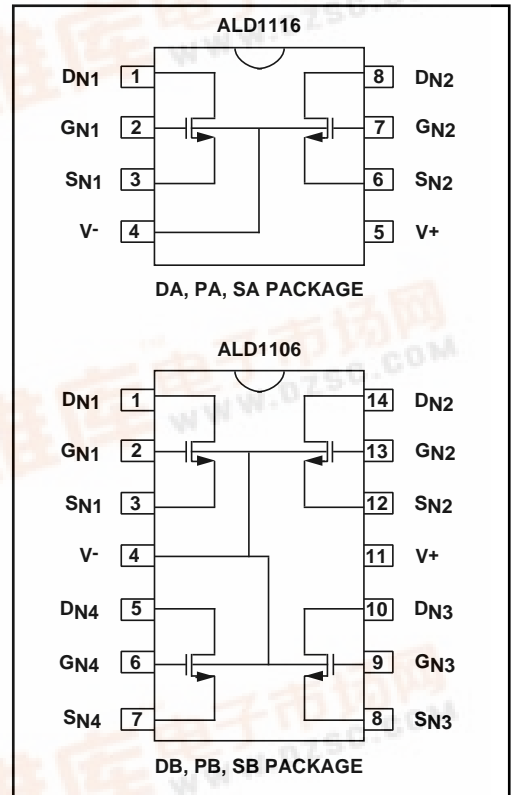

BLOCK DIAGRAM

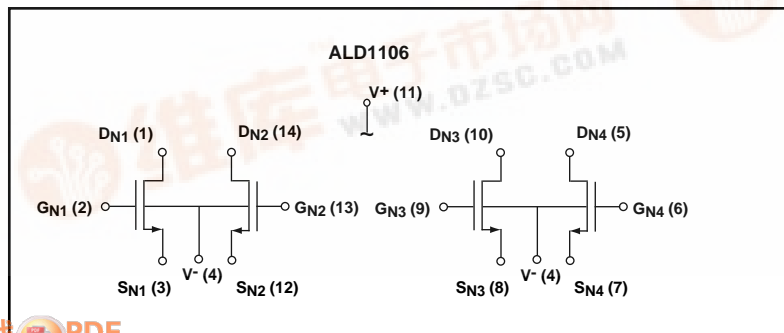

BLOCK DIAGRAM

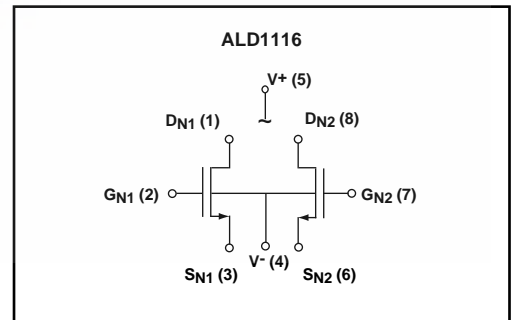

ABSOLUTE MAXIMUM RATINGS

Drain-source voltage, V_{DS}	_____	13.2V
Gate-source voltage, V_{GS}	_____	13.2V
Power dissipation	_____	500 mW
Operating temperature range	PA, SA, PB, SB package _____	0°C to +70°C
	DA, DB package _____	-55°C to +125°C
Storage temperature range	_____	-65°C to +150°C
Lead temperature, 10 seconds	_____	+260°C

OPERATING ELECTRICAL CHARACTERISTICS

$T_A = 25^\circ\text{C}$ unless otherwise specified

Parameter	Symbol	ALD1106			ALD1116			Unit	Test Conditions
		Min	Typ	Max	Min	Typ	Max		
Gate Threshold Voltage	V_T	0.4	0.7	1.0	0.4	0.7	1.0	V	$I_{DS} = 1.0\mu\text{A}$ $V_{GS} = V_{DS}$
Offset Voltage $V_{GS1} - V_{GS2}$	V_{OS}		2	10		2	10	mV	$I_{DS} = 10\mu\text{A}$ $V_{GS} = V_{DS}$
Gate Threshold Temperature Drift ²	TC_{VT}		-1.2			-1.2		mV/°C	
On Drain Current	$I_{DS(ON)}$	3.0	4.8		3.0	4.8		mA	$V_{GS} = V_{DS} = 5\text{V}$
Transconductance	G_{IS}	1.0	1.8		1.0	1.8		mmho	$V_{DS} = 5\text{V}$ $I_{DS} = 10\text{mA}$
Mismatch	ΔG_{fs}		0.5			0.5		%	
Output Conductance	G_{OS}		200			200		μmho	$V_{DS} = 5\text{V}$ $I_{DS} = 10\text{mA}$
Drain Source On Resistance	$R_{DS(ON)}$		350	500		350	500	Ω	$V_{DS} = 0.1\text{V}$ $V_{GS} = 5\text{V}$
Drain Source On Resistance Mismatch	$\Delta_{DS(ON)}$		0.5			0.5		%	$V_{DS} = 0.1\text{V}$ $V_{GS} = 5\text{V}$
Drain Source Breakdown Voltage	BV_{DSS}	12			12			V	$I_{DS} = 1.0\mu\text{A}$ $V_{GS} = 0\text{V}$
Off Drain Current ¹	$I_{DS(OFF)}$		10	400 4		10	400 4	pA nA	$V_{DS} = 12\text{V}$ $V_{GS} = 0\text{V}$ $T_A = 125^\circ\text{C}$
Gate Leakage Current	I_{GSS}		0.1	10 1		0.1	10 1	pA nA	$V_{DS} = 0\text{V}$ $V_{GS} = 12\text{V}$ $T_A = 125^\circ\text{C}$
Input Capacitance ²	C_{ISS}		1	3		1	3	pF	

Notes: ¹ Consists of junction leakage currents
² Sample tested parameters

TYPICAL PERFORMANCE CHARACTERISTICS

OUTPUT CHARACTERISTICS

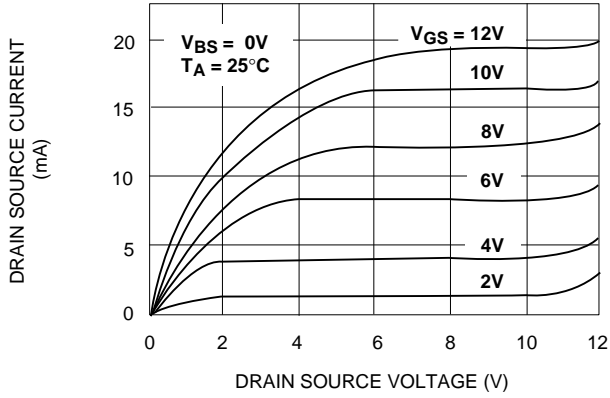

LOW VOLTAGE OUTPUT CHARACTERISTICS

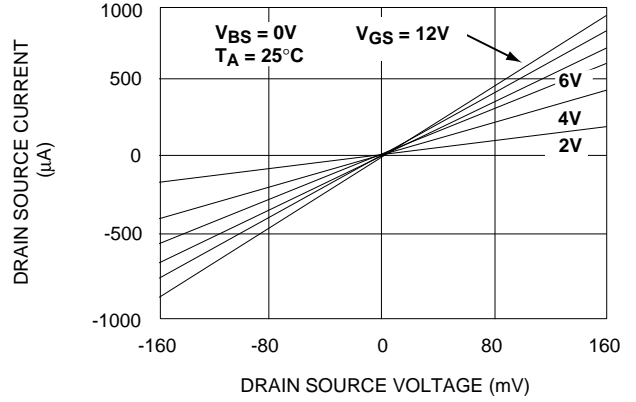

FORWARD TRANSCONDUCTANCE vs. DRAIN SOURCE VOLTAGE

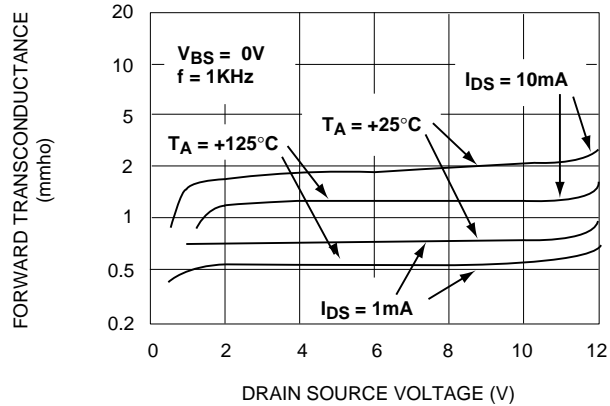

TRANSFER CHARACTERISTIC WITH SUBSTRATE BIAS

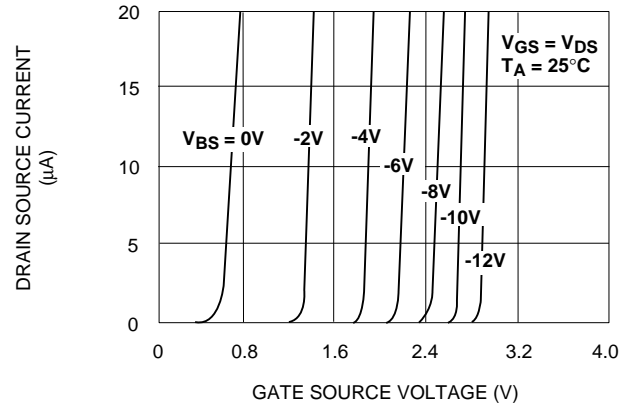

DRAIN SOURCE ON RESISTANCE $R_{DS(ON)}$ vs. GATE SOURCE VOLTAGE

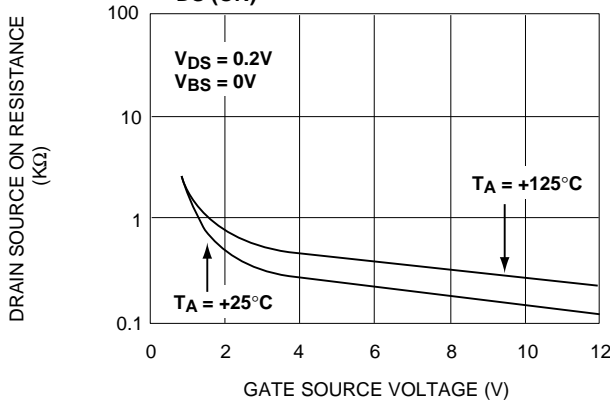

OFF DRAIN CURRENT vs. AMBIENT TEMPERATURE

