



AM1214-130

RF POWER TRANSISTORS

L-BAND RADAR APPLICATIONS

TARGET DATA

- REFRACTORY /GOLD METALLIZATION
- EMITTER SITE BALLASTING
- LOW RF THERMAL RESISTANCE
- INPUT/OUTPUT MATCHING
- OVERLAY GEOMETRY
- METAL/CERAMIC HERMETIC PACKAGE
- P_{OUT} = 130 W MIN. WITH 8.0 dB GAIN
- 1215-1400 MHz OPERATION

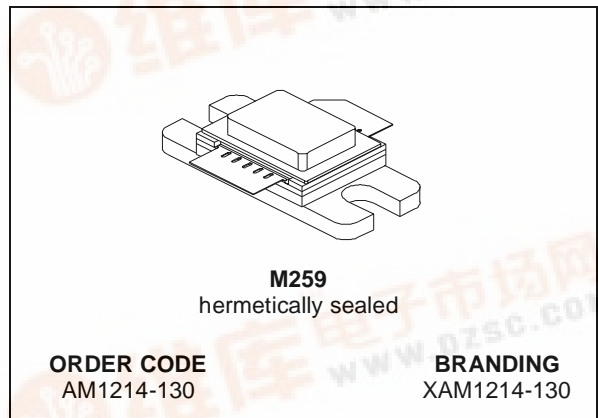

DESCRIPTION

The AM1214-130 is a rugged, Class C common base device designed as driver of AM1214-250 for new L - Band medium & long pulse radar applications.

Minimal amplitude droop over a long pulse of 500 microsec. is guaranteed by a thermal design incorporating an overlay site-ballasted die geometry.

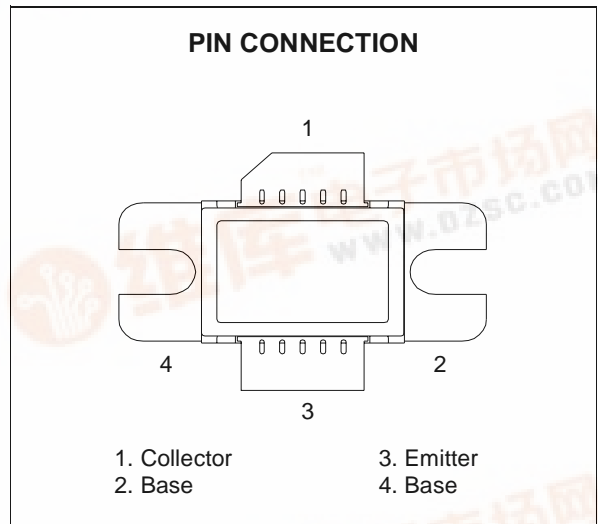

ABSOLUTE MAXIMUM RATINGS (T_{CASE} = 25°C)

Symbol	Parameter	Value	Unit
P _{DISS}	Power Dissipation (T _C ≤ 85°C)*	TBD	W
I _C	Device Current*	12	A
V _{CB0}	Collector-Base Voltage	70	V
T _j	Operating Junction Temperature	+250	°C
T _{STG}	Storage Temperature	-65 to +200	°C

THERMAL DATA

R _{th(j-c)}	Junction -Case Thermal Resistance*	TBD	°C/W
----------------------	------------------------------------	-----	------

* Applies only to rated RF amplifier operation: 150 microsec / 10%

AM1214-130

ELECTRICAL SPECIFICATION (T_{CASE} = 25°C)

STATIC

Symbol	Test Conditions			Min.	Typ.	Max.	Unit
BV _{CB0}	I _C = 20 mA	I _E = 0 mA		70			V
BV _{CES}	I _C = 20 mA	V _{BE} = 0 V		70			V
BV _{EBO}	I _E = 10 mA	I _C = 0 mA		3.5			V
I _{CES}	V _{CE} = 40 V	V _{BE} = 0 V				5	mA
h _{FE}	V _{CE} = 5 V	I _C = 0.25 A		10			

DYNAMIC @ 150 MICROSEC / 10 %

Symbol	Test Conditions			Min.	Typ.	Max.	Unit
P _{OUT}	f = 1215 - 1400 MHz	P _{IN} = 20 W	V _{CC} = 50 V	130	160		W
η _C	f = 1215 - 1400 MHz	P _{IN} = 20 W	V _{CC} = 50 V	40	45		%
G _P	f = 1215 - 1400 MHz	P _{IN} = 20 W	V _{CC} = 50 V	8.1	9.0		dB

DYNAMIC @ 500 MICROSEC / 10 %

Symbol	Test Conditions			Min.	Typ.	Max.	Unit
P _{OUT}	f = 1215 - 1400 MHz	P _{IN} = 20 W	V _{CC} = 50 V	110	140		W
η _C	f = 1215 - 1400 MHz	P _{IN} = 20 W	V _{CC} = 50 V	40	45		%
G _P	f = 1215 - 1400 MHz	P _{IN} = 20 W	V _{CC} = 50 V	7.4	8.45		dB

M259 (.400 x .500 SUPER WIDE 2/L HERM. W/FLG) MECHANICAL DATA

DIM.	mm			Inch		
	MIN.	TYP.	MAX	MIN.	TYP.	MAX
A	7.49		7.75	.295		.305
B	19.56		21.08	.770		.830
C	9.65		9.91	.380		.390
D	3.18		3.43	.125		.135
E		4.90			.193	
F	10.03		10.34	.395		.407
G	12.45		12.95	.490		.510
H	16.38		16.64	.645		.655
I		3.18			.125	
J	22.61		23.11	.890		.910
K	0.05		0.15	.002		.006
L	1.40		1.65	.055		.065
M	2.79		3.30	.110		.130
N			5.84			.230

M259, Package Outline

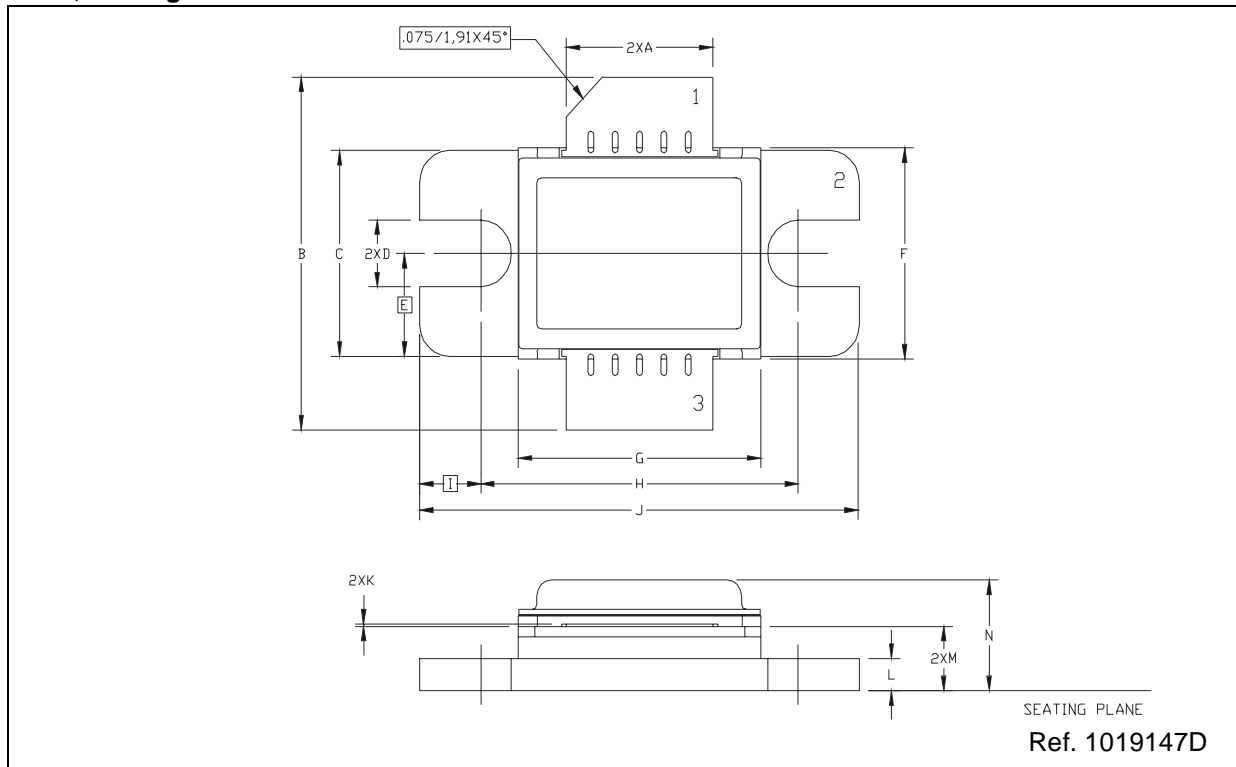

Information furnished is believed to be accurate and reliable. However, STMicroelectronics assumes no responsibility for the consequences of use of such information nor for any infringement of patents or other rights of third parties which may result from its use. No license is granted by implication or otherwise under any patent or patent rights of STMicroelectronics. Specifications mentioned in this publication are subject to change without notice. This publication supersedes and replaces all information previously supplied. STMicroelectronics products are not authorized for use as critical components in life support devices or systems without express written approval of STMicroelectronics.

The ST logo is registered trademark of STMicroelectronics
© 2000 STMicroelectronics - All Rights Reserved

All other names are the property of their respective owners.

STMicroelectronics GROUP OF COMPANIES
Australia - Brazil - China - Finland - France - Germany - Hong Kong - India - Italy - Japan - Malaysia - Malta - Morocco -
Singapore - Spain - Sweden - Switzerland - United Kingdom - U.S.A.

<http://www.st.com>