

- Meets or Exceeds the Requirements of TIA/EIA-422-B and ITU Recommendation V.11
- Low Power,  $I_{CC} = 100 \mu A$  Typ
- Operates From a Single 5-V Supply
- High Speed,  $t_{PLH} = t_{PHL} = 7$  ns Typ
- Low Pulse Distortion,  $t_{sk(p)} = 0.5$  ns Typ
- High Output Impedance in Power-Off Conditions
- Improved Replacement for AM26LS31
- Available in Q-Temp Automotive
  - High-Reliability Automotive Applications
  - Configuration Control/Print Support
  - Qualification to Automotive Standards

**description**

The AM26C31 is a differential line driver with complementary outputs, designed to meet the requirements of TIA/EIA-422-B and ITU (formerly CCITT). The 3-state outputs have high-current capability for driving balanced lines, such as twisted-pair or parallel-wire transmission lines, and they provide the high-impedance state in the power-off condition. The enable functions are common to all four drivers and offer the choice of an active-high (G) or active-low ( $\bar{G}$ ) enable input. BiCMOS circuitry reduces power consumption without sacrificing speed.

The AM26C31C is characterized for operation from 0°C to 70°C, the AM26C31I is characterized for operation from -40°C to 85°C, the AM26C31Q is characterized for operation over the automotive temperature range of -40°C to 125°C, and the AM26C31M is characterized for operation over the full military temperature range of -55°C to 125°C.

AM26C31M . . . J OR W PACKAGE  
AM26C31C/I/Q . . . D, DB, N, OR NS PACKAGE  
(TOP VIEW)

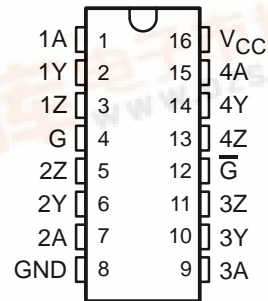

AM26C31M . . . FK PACKAGE  
(TOP VIEW)

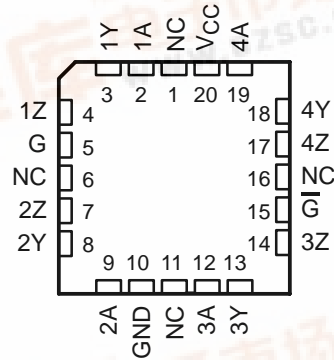

NC – No internal connection

**AVAILABLE OPTIONS**

TA	PACKAGED DEVICES					
	PLASTIC SMALL OUTLINE (D, NS)	PLASTIC SHRINK SMALL OUTLINE (DB)	PLASTIC DIP (N)	CERAMIC CHIP CARRIER (FK)	CERAMIC DIP (J)	CERAMIC DUAL FLATPACK (W)
0°C to 70°C	AM26C31CD AM26C31CNS	AM26C31CDB —	AM26C31CN —	—	—	—
-40°C to 85°C	AM26C31ID AM26C31INS	AM26C31IDB —	AM26C31IN —	—	—	—
-40°C to 125°C	AM26C31QD	AM26C31QDB	AM26C31QN	—	—	—
-55°C to 125°C	—	—	—	AM26C31MFK	AM26C31MJ	AM26C31MW

The D package also is available taped and reeled. Add the suffix R to device type (e.g., AM26C31CDR). The DB and NS packages are only available taped and reeled.

Please be aware that an important notice concerning availability, standard warranty, and use in critical applications of Texas Instruments semiconductor products and disclaimers thereto appears at the end of this data sheet.



# AM26C31 QUADRUPLE DIFFERENTIAL LINE DRIVER

SLLS103I – DECEMBER 1990 – REVISED FEBRUARY 2002

FUNCTION TABLE  
(each driver)

INPUT A	ENABLES		OUTPUTS	
	G	$\bar{G}$	Y	Z
H	H	X	H	L
L	H	X	L	H
H	X	L	H	L
L	X	L	L	H
X	L	H	Z	Z

H = High level, L = Low level, X = Irrelevant,  
Z = High impedance (off)

## logic diagram (positive logic)

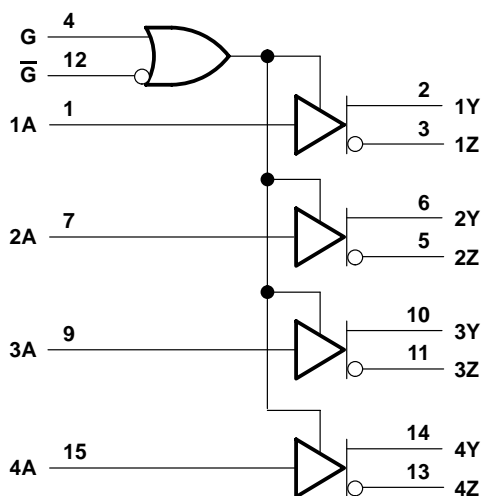

## schematics of inputs and outputs

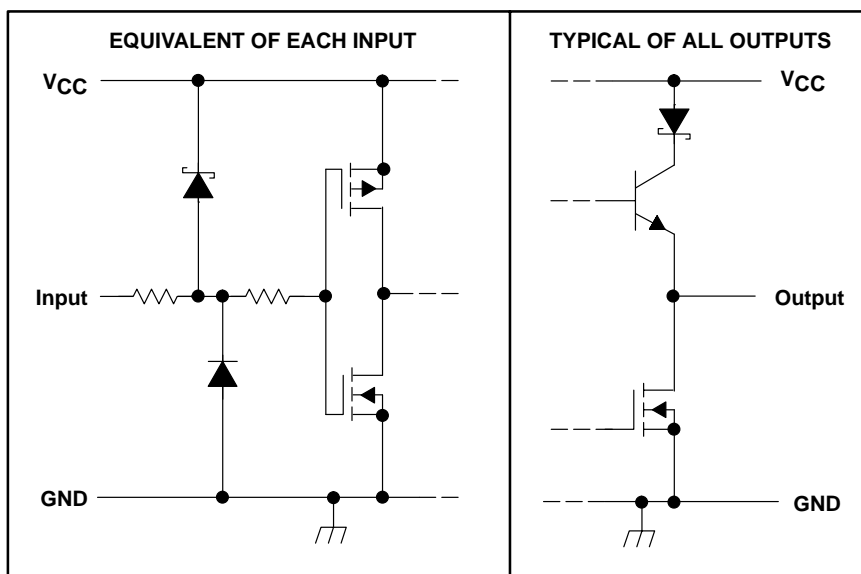

# AM26C31 QUADRUPLE DIFFERENTIAL LINE DRIVER

SLLS103I – DECEMBER 1990 – REVISED FEBRUARY 2002

## absolute maximum ratings over operating free-air temperature range (unless otherwise noted)†

Supply voltage range, $V_{CC}$ (see Note 1)	–0.5 V to 7 V
Input voltage range, $V_I$	–0.5 V to $V_{CC} + 0.5$ V
Differential input voltage range, $V_{ID}$	–14 V to 14 V
Output voltage range, $V_O$	–0.5 V to 7 V
Input or output clamp current, $I_{IK}$ or $I_{OK}$	±20 mA
Output current, $I_O$	±150 mA
$V_{CC}$ current	200 mA
GND current	–200 mA
Continuous total power dissipation	See Dissipation Rating Table
Package thermal impedance, $\theta_{JA}$ (see Note 2): D package	73°C/W
DB package	82°C/W
N package	67°C/W
NS package	64°C/W
Lead temperature 1,6 mm (1/16 inch) from case for 10 seconds	260°C
Storage temperature range, $T_{stg}$	–65°C to 150°C

† Stresses beyond those listed under “absolute maximum ratings” may cause permanent damage to the device. These are stress ratings only, and functional operation of the device at these or any other conditions beyond those indicated under “recommended operating conditions” is not implied. Exposure to absolute-maximum-rated conditions for extended periods may affect device reliability.

- NOTES: 1. All voltage values, except differential output voltage ( $V_{OD}$ ), are with respect to the network ground terminal.  
 2. The package thermal impedance is calculated in accordance with JESD 51-7.

**DISSIPATION RATING TABLE**

PACKAGE	$T_A \leq 25^\circ\text{C}$ POWER RATING	DERATING FACTOR ABOVE $T_A = 25^\circ\text{C}$	$T_A = 125^\circ\text{C}$ POWER RATING
FK	1375 mW	11 mW/°C	275 mW
J	1375 mW	11 mW/°C	275 mW
W	1000 mW	8.0 mW/°C	200 mW

## recommended operating conditions

		MIN	NOM	MAX	UNIT
$V_{CC}$	Supply voltage	4.5	5	5.5	V
$V_{ID}$	Differential input voltage		±7		V
$V_{IH}$	High-level input voltage	2			V
$V_{IL}$	Low-level input voltage			0.8	V
$I_{OH}$	High-level output current			–20	V
$I_{OL}$	Low-level output current			20	V
$T_A$	Operating free-air temperature	AM26C31C	0	70	°C
		AM26C31I	–40	85	
		AM26C31Q	–40	125	
		AM26C31M	–55	125	

# AM26C31

## QUADRUPLE DIFFERENTIAL LINE DRIVER

SLLS103I – DECEMBER 1990 – REVISED FEBRUARY 2002

### electrical characteristics over recommended ranges of supply voltage and operating free-air temperature (unless otherwise noted)

PARAMETER	TEST CONDITIONS	AM26C31C AM26C31I			UNIT
		MIN	TYP†	MAX	
V <sub>OH</sub> High-level output voltage	I <sub>O</sub> = -20 mA	2.4	3.4		V
V <sub>OL</sub> Low-level output voltage	I <sub>O</sub> = 20 mA		0.2	0.4	V
V <sub>OD</sub>   Differential output voltage magnitude	R <sub>L</sub> = 100 Ω, See Figure 1	2	3.1		V
Δ V <sub>OD</sub>   Change in magnitude of differential output voltage‡	R <sub>L</sub> = 100 Ω, See Figure 1			±0.4	V
V <sub>OC</sub> Common-mode output voltage	R <sub>L</sub> = 100 Ω, See Figure 1			3	V
Δ V <sub>OC</sub>   Change in magnitude of common-mode output voltage‡	R <sub>L</sub> = 100 Ω, See Figure 1			±0.4	V
I <sub>I</sub> Input current	V <sub>I</sub> = V <sub>CC</sub> or GND			±1	μA
I <sub>O(off)</sub> Driver output current with power off	V <sub>CC</sub> = 0 V <sub>O</sub> = 6 V V <sub>O</sub> = -0.25 V			100 -100	μA
I <sub>OS</sub> Driver output short-circuit current	V <sub>O</sub> = 0	-30		-150	mA
I <sub>OZ</sub> High-impedance off-state output current	V <sub>O</sub> = 2.5 V V <sub>O</sub> = 0.5 V			20 -20	μA
I <sub>CC</sub> Quiescent supply current	I <sub>O</sub> = 0 V <sub>I</sub> = 0 V or 5 V V <sub>I</sub> = 2.4 V or 0.5 V, See Note 3		1.5	3	mA
C <sub>i</sub> Input capacitance			6		pF

† All typical values are at V<sub>CC</sub> = 5 V and T<sub>A</sub> = 25°C.

‡ Δ|V<sub>OD</sub>| and Δ|V<sub>OC</sub>| are the changes in magnitude of V<sub>OD</sub> and V<sub>OC</sub>, respectively, that occur when the input is changed from a high level to a low level.

NOTE 3: This parameter is measured per input. All other inputs are at 0 or 5 V.

### switching characteristics over recommended ranges of supply voltage and operating free-air temperature (unless otherwise noted)

PARAMETER	TEST CONDITIONS	AM26C31C AM26C31I			UNIT
		MIN	TYP†	MAX	
t <sub>PLH</sub> Propagation delay time, low- to high-level output	S1 is open, See Figure 2	3	7	12	ns
t <sub>PHL</sub> Propagation delay time, high- to low-level output	S1 is open, See Figure 2	3	7	12	ns
t <sub>sk(p)</sub> Pulse skew time ( t <sub>PLH</sub> - t <sub>PHL</sub>  )	S1 is open, See Figure 2		0.5	4	ns
t <sub>r(OD)</sub> , t <sub>f(OD)</sub> Differential output rise and fall times	S1 is open, See Figure 3		5	10	ns
t <sub>PZH</sub> Output enable time to high level	S1 is closed, See Figure 4		10	19	ns
t <sub>PZL</sub> Output enable time to low level	S1 is closed, See Figure 4		10	19	ns
t <sub>PHZ</sub> Output disable time from high level	S1 is closed, See Figure 4		7	16	ns
t <sub>PLZ</sub> Output disable time from low level	S1 is closed, See Figure 4		7	16	ns
C <sub>pd</sub> Power dissipation capacitance (each driver) (see Note 4)	S1 is open, See Figure 2		170		pF

† All typical values are at V<sub>CC</sub> = 5 V and T<sub>A</sub> = 25°C.

NOTE 4: C<sub>pd</sub> is used to estimate the switching losses according to P<sub>D</sub> = C<sub>pd</sub> × V<sub>CC</sub><sup>2</sup> × f, where f is the switching frequency.

# AM26C31 QUADRUPLE DIFFERENTIAL LINE DRIVER

SLLS1031 – DECEMBER 1990 – REVISED FEBRUARY 2002

**electrical characteristics over recommended ranges of supply voltage and operating free-air temperature (unless otherwise noted)**

PARAMETER	TEST CONDITIONS	AM26C31Q AM26C31M			UNIT
		MIN	TYP†	MAX	
V <sub>OH</sub> High-level output voltage	I <sub>O</sub> = -20 mA	2.2	3.4		V
V <sub>OL</sub> Low-level output voltage	I <sub>O</sub> = 20 mA		0.2	0.4	V
V <sub>OD</sub>   Differential output voltage magnitude	R <sub>L</sub> = 100 Ω, See Figure 1	2	3.1		V
Δ V <sub>OD</sub>   Change in magnitude of differential output voltage‡	R <sub>L</sub> = 100 Ω, See Figure 1			±0.4	V
V <sub>OC</sub> Common-mode output voltage	R <sub>L</sub> = 100 Ω, See Figure 1			3	V
Δ V <sub>OC</sub>   Change in magnitude of common-mode output voltage‡	R <sub>L</sub> = 100 Ω, See Figure 1			±0.4	V
I <sub>I</sub> Input current	V <sub>I</sub> = V <sub>CC</sub> or GND			±1	μA
I <sub>O(off)</sub> Driver output current with power off	V <sub>CC</sub> = 0 V <sub>O</sub> = 6 V V <sub>O</sub> = -0.25 V			100 -100	μA
I <sub>OS</sub> Driver output short-circuit current	V <sub>O</sub> = 0			-170	mA
I <sub>OZ</sub> High-impedance off-state output current	V <sub>O</sub> = 2.5 V V <sub>O</sub> = 0.5 V			20 -20	μA
I <sub>CC</sub> Quiescent supply current	I <sub>O</sub> = 0 V <sub>I</sub> = 0 V or 5 V			100	μA
	I <sub>O</sub> = 0 V <sub>I</sub> = 2.4 V or 0.5 V, See Note 3			3.2	mA
C <sub>i</sub> Input capacitance			6		pF

† All typical values are at V<sub>CC</sub> = 5 V and T<sub>A</sub> = 25°C.

‡ Δ|V<sub>OD</sub>| and Δ|V<sub>OC</sub>| are the changes in magnitude of V<sub>OD</sub> and V<sub>OC</sub>, respectively, that occur when the input is changed from a high level to a low level.

NOTE 3: This parameter is measured per input. All other inputs are at 0 V or 5 V.

**switching characteristics over recommended ranges of supply voltage and operating free-air temperature (unless otherwise noted)**

PARAMETER	TEST CONDITIONS	AM26C31Q AM26C31M			UNIT
		MIN	TYP†	MAX	
t <sub>PLH</sub> Propagation delay time, low- to high-level output	S1 is open, See Figure 2		7	12	ns
t <sub>PHL</sub> Propagation delay time, high- to low-level output	S1 is open, See Figure 2		6.5	12	ns
t <sub>sk(p)</sub> Pulse skew time ( t <sub>PLH</sub> - t <sub>PHL</sub>  )	S1 is open, See Figure 2		0.5	4	ns
t <sub>r(OD)</sub> , t <sub>f(OD)</sub> Differential output rise and fall times	S1 is open, See Figure 3		5	12	ns
t <sub>PZH</sub> Output enable time to high level	S1 is closed, See Figure 4		10	19	ns
t <sub>PZL</sub> Output enable time to low level	S1 is closed, See Figure 4		10	19	ns
t <sub>PHZ</sub> Output disable time from high level	S1 is closed, See Figure 4		7	16	ns
t <sub>PLZ</sub> Output disable time from low level	S1 is closed, See Figure 4		7	16	ns
C <sub>pd</sub> Power dissipation capacitance (each driver) (see Note 4)	S1 is open, See Figure 2		100		pF

† All typical values are at V<sub>CC</sub> = 5 V and T<sub>A</sub> = 25°C.

NOTE 4: C<sub>pd</sub> is used to estimate the switching losses according to P<sub>D</sub> = C<sub>pd</sub> × V<sub>CC</sub><sup>2</sup> × f, where f is the switching frequency.

# AM26C31 QUADRUPLE DIFFERENTIAL LINE DRIVER

SLLS103I – DECEMBER 1990 – REVISED FEBRUARY 2002

## PARAMETER MEASUREMENT INFORMATION

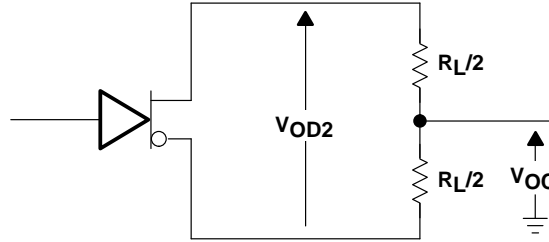
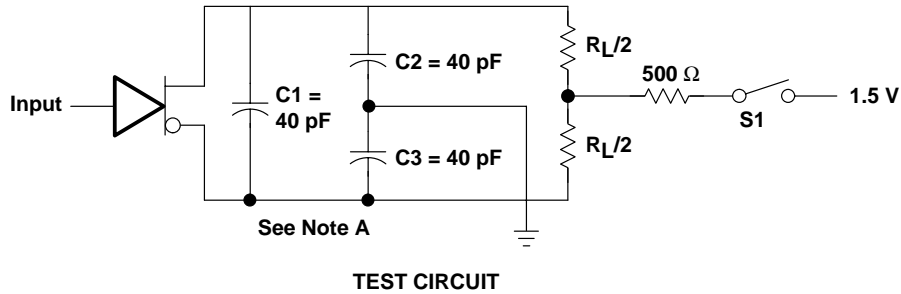
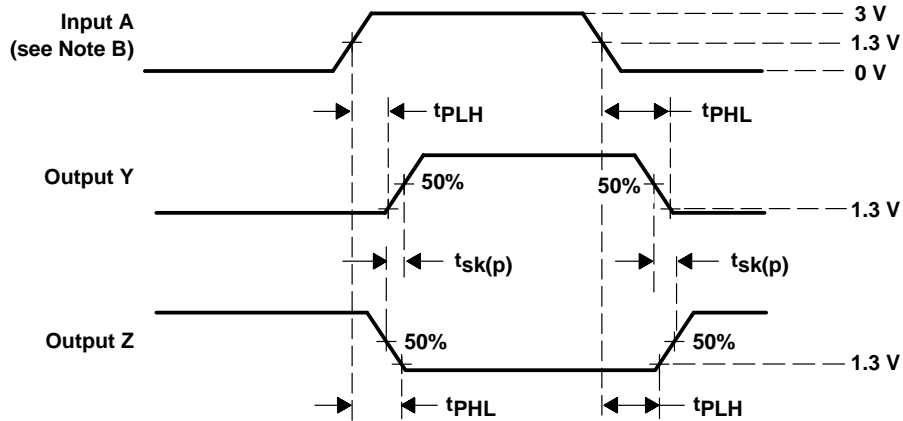

Figure 1. Differential and Common-Mode Output Voltages



TEST CIRCUIT



- NOTES: A.  $C1$ ,  $C2$ , and  $C3$  include probe and jig capacitance.  
B. All input pulses are supplied by generators having the following characteristics:  $PRR \leq 1 \text{ MHz}$ , duty cycle  $\leq 50\%$ , and  $t_r, t_f \leq 6 \text{ ns}$ .

Figure 2. Propagation Delay Time and Skew Waveforms and Test Circuit

# AM26C31 QUADRUPLE DIFFERENTIAL LINE DRIVER

SLLS103I – DECEMBER 1990 – REVISED FEBRUARY 2002

## PARAMETER MEASUREMENT INFORMATION

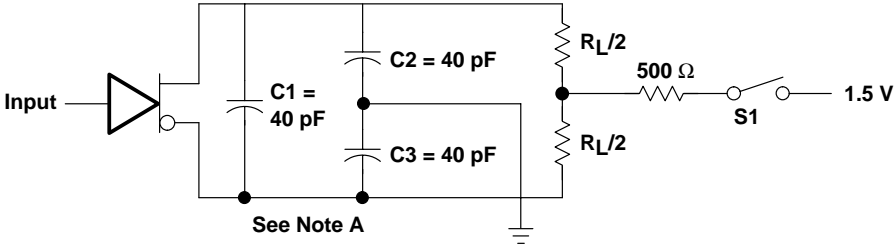

TEST CIRCUIT

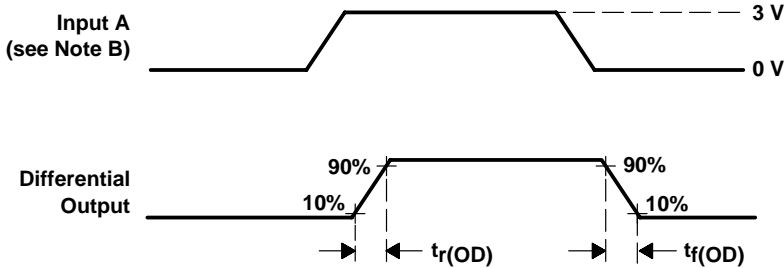

VOLTAGE WAVEFORMS

- NOTES: A. C1, C2, and C3 include probe and jig capacitance.  
 B. All input pulses are supplied by generators having the following characteristics: PRR ≤ 1 MHz, duty cycle ≤ 50%, and tr, tf ≤ 6 ns.

**Figure 3. Differential-Output Rise- and Fall-Time Waveforms and Test Circuit**

# AM26C31 QUADRUPLE DIFFERENTIAL LINE DRIVER

SLLS103I – DECEMBER 1990 – REVISED FEBRUARY 2002

## PARAMETER MEASUREMENT INFORMATION

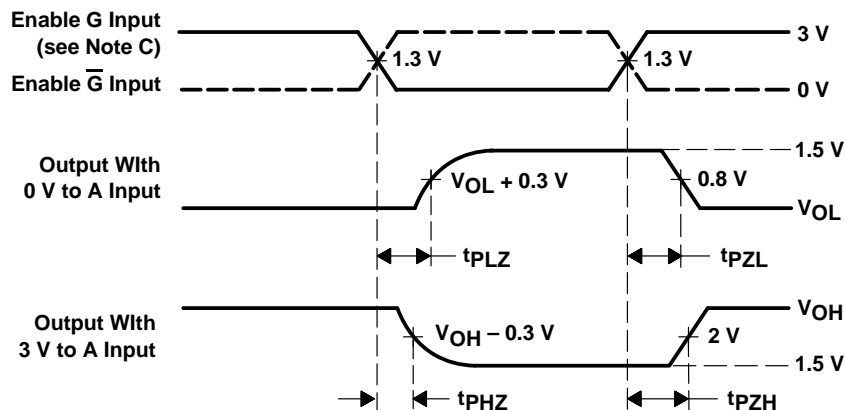
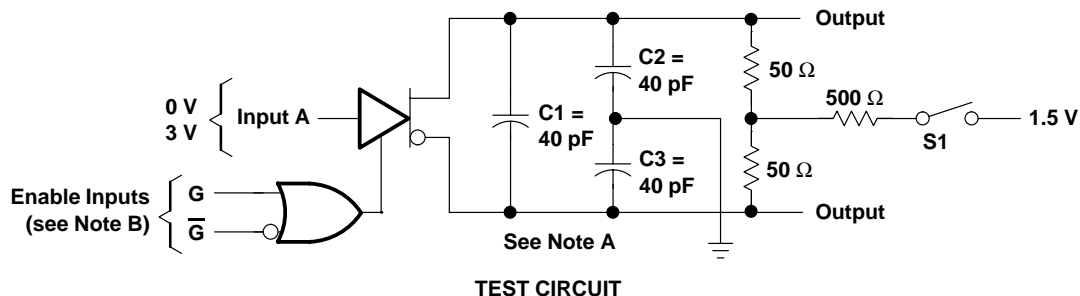

- NOTES: A. C1, C2, and C3 includes probe and jig capacitance.  
 B. All input pulses are supplied by generators having the following characteristics: PRR ≤ 1 MHz, duty cycle ≤ 50%,  $t_r < 6$  ns, and  $t_f < 6$  ns.  
 C. Each enable is tested separately.

**Figure 4. Output Enable- and Disable-Time Waveforms and Test Circuit**



**AM26C31  
QUADRUPLE DIFFERENTIAL LINE DRIVER**

SLLS103I – DECEMBER 1990 – REVISED FEBRUARY 2002

**TYPICAL CHARACTERISTICS**

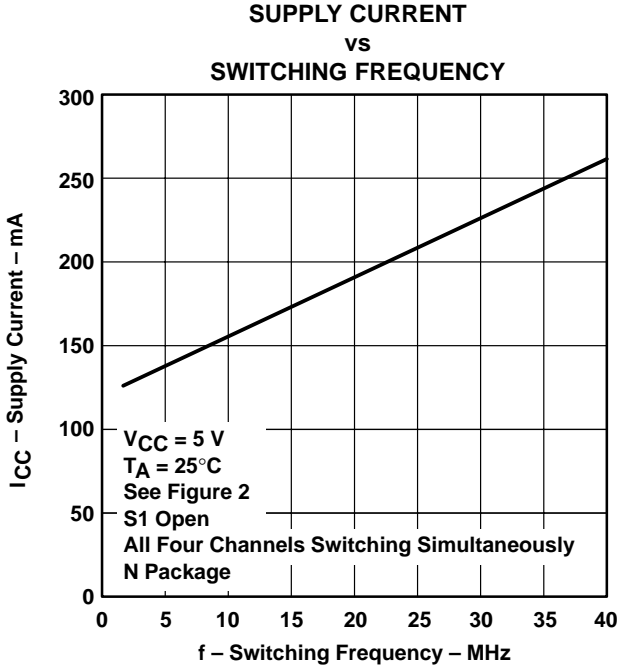

**Figure 5**

## **IMPORTANT NOTICE**

Texas Instruments Incorporated and its subsidiaries (TI) reserve the right to make corrections, modifications, enhancements, improvements, and other changes to its products and services at any time and to discontinue any product or service without notice. Customers should obtain the latest relevant information before placing orders and should verify that such information is current and complete. All products are sold subject to TI's terms and conditions of sale supplied at the time of order acknowledgment.

TI warrants performance of its hardware products to the specifications applicable at the time of sale in accordance with TI's standard warranty. Testing and other quality control techniques are used to the extent TI deems necessary to support this warranty. Except where mandated by government requirements, testing of all parameters of each product is not necessarily performed.

TI assumes no liability for applications assistance or customer product design. Customers are responsible for their products and applications using TI components. To minimize the risks associated with customer products and applications, customers should provide adequate design and operating safeguards.

TI does not warrant or represent that any license, either express or implied, is granted under any TI patent right, copyright, mask work right, or other TI intellectual property right relating to any combination, machine, or process in which TI products or services are used. Information published by TI regarding third-party products or services does not constitute a license from TI to use such products or services or a warranty or endorsement thereof. Use of such information may require a license from a third party under the patents or other intellectual property of the third party, or a license from TI under the patents or other intellectual property of TI.

Reproduction of information in TI data books or data sheets is permissible only if reproduction is without alteration and is accompanied by all associated warranties, conditions, limitations, and notices. Reproduction of this information with alteration is an unfair and deceptive business practice. TI is not responsible or liable for such altered documentation.

Resale of TI products or services with statements different from or beyond the parameters stated by TI for that product or service voids all express and any implied warranties for the associated TI product or service and is an unfair and deceptive business practice. TI is not responsible or liable for any such statements.

### **Mailing Address:**

Texas Instruments  
Post Office Box 655303  
Dallas, Texas 75265