

Am9513

System Timing Controller
Advanced Micro Devices
Advanced MOS/LSI

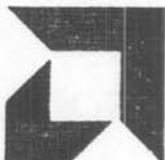

DISTINCTIVE CHARACTERISTICS

- Five independent 16-bit counters
- High speed counting rates
- Up/down and binary/BCD counting
- Internal oscillator frequency source
- Tapped frequency scaler
- Programmable frequency output
- 8-bit or 16-bit bus interface
- Time-of-day option
- Alarm comparators on counters 1 and 2
- Complex duty cycle outputs
- One-shot or continuous outputs
- Programmable count/gate source selection
- Programmable input and output polarities
- Programmable gating functions
- Retriggering capability
- +5 volt power supply
- Standard 40-pin package
- 100% MIL-STD-883 reliability assurance testing

GENERAL DESCRIPTION

The Am9513 System Timing Controller is an LSI circuit designed to service many types of counting, sequencing and timing applications. It provides the capability for programmable frequency synthesis, high resolution programmable duty cycle waveforms, retriggerable digital timing functions, time-of-day clocking, coincidence alarms, complex pulse generation, high resolution baud rate generation, frequency shift keying, stop-watching timing, event count accumulation, waveform analysis and many more. A variety of programmable operating modes and control features allow the Am9513 to be personalized for particular applications as well as dynamically reconfigured under program control.

The STC includes five general-purpose 16-bit counters. A variety of internal frequency sources and external pins may be selected as inputs for individual counters with software selectable active-high or active-low input polarity. Both hardware and software gating of each counter is available. Three-state outputs for each counter provide either pulses or levels. The counters can be programmed to count up or down in either binary or BCD. The accumulated count may be read without disturbing the counting process. Any of the counters may be internally concatenated to form an effective counter length of up to 80 bits.

TABLE OF CONTENTS

General Description	1
Pinout	1
Block Diagram	2
Interface Signal Description	2
Functional Description	4
Control Port Registers	5
Data Port Registers	7
Register Access	8
Master Mode Control Options	9
Operating Mode Description	11
Counter Mode Control Options	15
Command Descriptions	17
Maximum Ratings	21
Electrical Characteristics	21
Switching Characteristics	23
Applications Information	25
Physical Dimensions	26

CONNECTION DIAGRAM

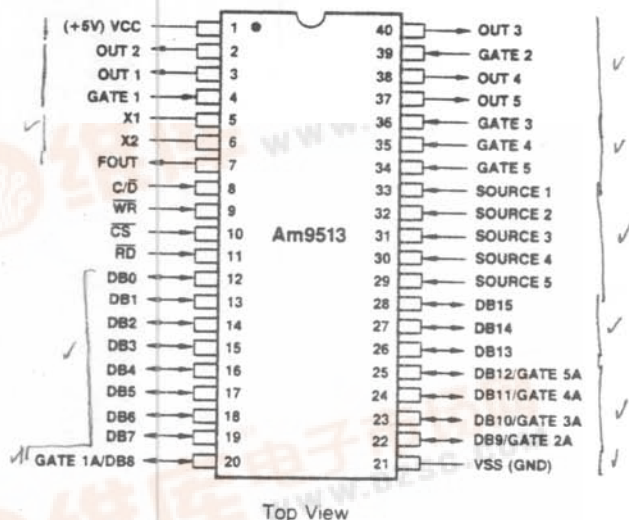

Top View

Pin 1 is marked for orientation.

MOS-172

Figure 1.

ORDERING INFORMATION

Package Type	Temperature Range	Counting Frequency	
		7MHz	
Molded	0°C ≤ T _A ≤ +70°C	AM9513PC	
Hermetic*		AM9513DC	
		AM9513CC	
Hermetic	-55°C ≤ T _A ≤ +125°C	AM9513DM	

*Hermetic = Ceramic = DC = CC = D-40-1.



GENERAL BLOCK DIAGRAM

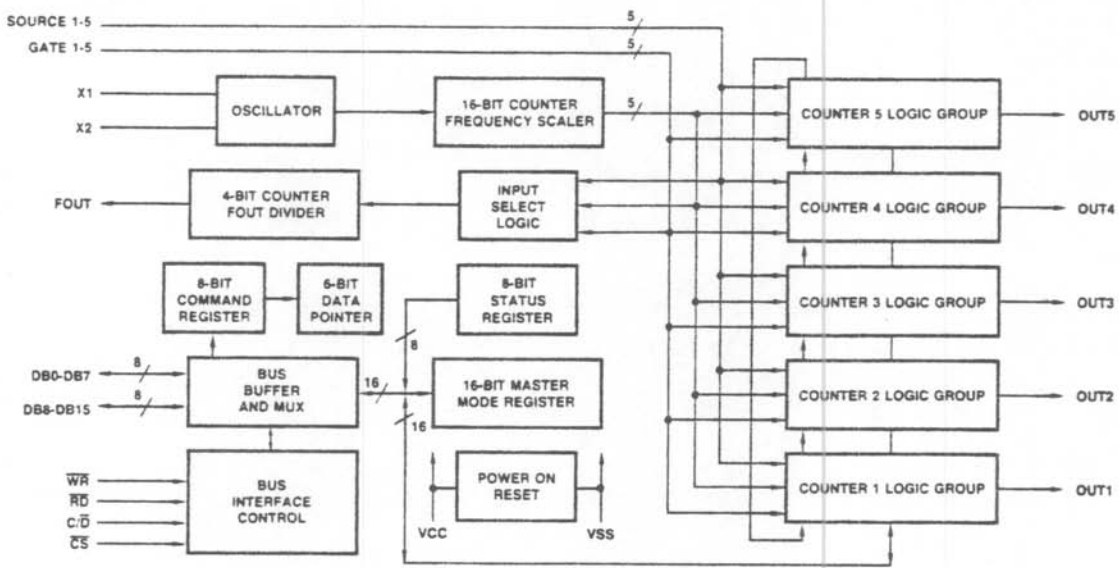

Figure 2.

MOS-169

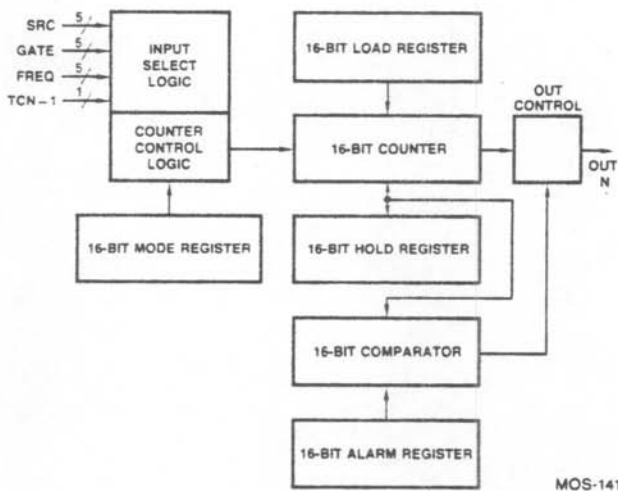

Figure 3. Counter Logic Groups 1 and 2.

MOS-141

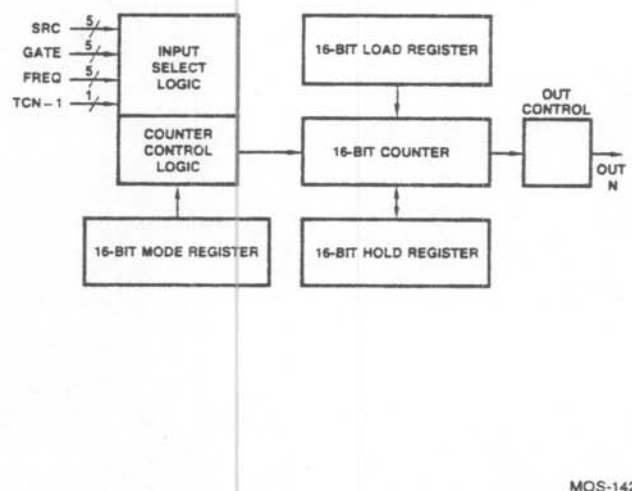

Figure 4. Counter Logic Groups 3, 4 and 5.

MOS-142

INTERFACE SIGNAL DESCRIPTION

Figure 5 summarizes the interface signals and their abbreviations for the STC. Figure 1 shows the signal pin assignments for the standard 40-pin dual in-line package.

VCC: +5 volt power supply

VSS: Ground

X1, X2 (Crystal)

X1 and X2 are the connections for an external crystal used to determine the frequency of the internal oscillator. The crystal should be a parallel-resonant, fundamental-mode type. An RC or LC or other reactive network may be used instead of a crystal. For driving from an external frequency source, X1 should be left open and X2 should be connected to a TTL source and a pull-up resistor.

FOUT (Frequency Out, Output)

The FOUT output is derived from a 4-bit counter that may be programmed to divide its input by any integer value from 1 through 16 inclusive. The input to the counter is selected from any of 15 sources, including the internal scaled oscillator frequencies. FOUT may be gated on and off under software control and when off will exhibit a low impedance to ground. Control over the various FOUT options resides in the Master Mode register. After power-up, FOUT provides a frequency that is 1/16 that of the oscillator.

GATE1-GATE5 (Gate, Inputs)

The Gate inputs may be used to control the operations of individual counters by determining when counting may proceed. The same Gate input may control up to three counters. Gate pins may also be selected as count sources for any of the counters and for the FOUT divider. The active polarity for a selected Gate input is programmed at each counter. Gating function options allow level-sensitive gating or edge-initiated gating. Other gating

modes are available including one that allows the Gate input to select between two counter output frequencies. All gating functions may also be disabled. The active Gate input is conditioned by an auxiliary input when the unit is operating with an external 8-bit data bus. See Data Bus description. Schmitt-trigger circuitry on the GATE inputs allows slow transition times to be used.

SRC1-SRC5 (Source, Inputs)

The Source inputs provide external signals that may be counted by any of the counters. Any Source line may be routed to any or all of the counters and the FOUT divider. The active polarity for a selected SRC input is programmed at each counter. Any duty cycle waveform will be accepted as long as the minimum pulse width is at least half the period of the maximum specified counting frequency for the part. Schmitt-trigger circuitry on the SRC inputs allows slow transition times to be used.

OUT1-OUT5 (Counter, Outputs)

Each 3-state OUT signal is directly associated with a corresponding individual counter. Depending on the counter configuration, the OUT signal may be a pulse, a square wave, or a complex duty cycle waveform. OUT pulse polarities are individually programmable. The output circuitry detects the counter state that would have been all bits zero in the absence of a reinitialization. That information is used to generate the selected waveform type. An optional output mode for Counters 1 and 2 overrides the normal output mode and provides a true OUT signal when the counter contents match the contents of an Alarm register.

DB0-DB7, DB8-DB15 (Data Bus, Input/Output)

The 16, bidirectional Data Bus lines are used for information exchanges with the host processor. HIGH on a Data Bus line corresponds to one and LOW corresponds to zero. These lines act as inputs when \overline{WR} and \overline{CS} are active and as outputs when \overline{RD} and \overline{CS} are active. When \overline{CS} is inactive, these pins are placed in a high-impedance state.

After power-up or reset, the data bus will be configured for 8-bit width and will use only DB0 through DB7. DB0 is the least significant and DB7 is the most significant bit position. The data bus may be reconfigured for 16-bit width by changing a control bit in

the Master Mode register. This is accomplished by writing an 8-bit command into the low-order DB lines while holding the DB13-DB15 lines at a logic high level. Thereafter all 16 lines can be used, with DB0 as the least significant and DB15 as the most significant bit position.

When operating in the 8-bit data bus environment, DB8-DB15 will never be driven active by the Am9513. DB8 through DB12 may optionally be used as additional Gate inputs (see Figure 6). If unused they should be held high. When pulled low, a GATENA signal will disable the action of the corresponding counter N gating. DB13-DB15 should be held high in 8-bit bus mode whenever CS and WR are simultaneously active.

\overline{CS} (Chip Select, Input)

The active-low Chip Select input enables Read and Write operations on the data bus. When Chip Select is high, the Read and Write inputs are ignored. The first Chip Select signal after power-up is used to clear the power-on reset circuitry.

\overline{RD} (Read, Input)

The active-low Read signal is conditioned by Chip Select and indicates that internal information is to be transferred to the data bus. The source will be determined by the port being addressed and, for Data Port reads, by the contents of the Data Pointer register. \overline{WR} and \overline{RD} should be mutually exclusive.

\overline{WR} (Write, Input)

The active-low Write signal is conditioned by Chip Select and indicates that data bus information is to be transferred to an internal location. The destination will be determined by the port being addressed and, for Data Port writes, by the contents of the Data Pointer register. \overline{WR} and \overline{RD} should be mutually exclusive.

C/\overline{D} (Control/Data, Input)

The Control/Data signal selects source and destination locations for read and write operations on the data bus. Control Write operations load the Command register and the Data Pointer. Control Read operations output the Status register. Data Read and Data Write transfers communicate with all other internal registers. Indirect addressing at the data port is controlled internally by the Data Pointer register.

Signal	Abbreviation	Type	Pins
+5 Volts	VCC	Power	1
Ground	VSS	Power	1
Crystal	X1, X2	I/O, I	2
Read	\overline{RD}	Input	1
Write	\overline{WR}	Input	1
Chip Select	\overline{CS}	Input	1
Control/Data	C/\overline{D}	Input	1
Source N	SRC	Input	5
Gate N	GATE	Input	5
Data Bus	DB	I/O	16
Frequency Out	FOUT	Output	1
Out N	OUT	Output	5

Figure 5. Interface Signal Summary.

Package Pin	Data Bus Width (MM14)	
	16 Bits	8 Bits
12	DB0	DB0
13	DB1	DB1
14	DB2	DB2
15	DB3	DB3
16	DB4	DB4
17	DB5	DB5
18	DB6	DB6
19	DB7	DB7
20	DB8	GATE 1A
22	DB9	GATE 2A
23	DB10	GATE 3A
24	DB11	GATE 4A
25	DB12	GATE 5A
26	DB13	(VIH)
27	DB14	(VIH)
28	DB15	(VIH)

Figure 6. Data Bus Assignments.

FUNCTIONAL DESCRIPTION

The Am9513 block diagrams (Figures 2, 3 and 4) indicate the interface signals and the basic flow of information. Internal control lines and the internal data bus have been omitted. The control and data registers are all connected to a common internal 16-bit bus. The external bus may be 8 or 16 bits wide; in the 8-bit mode the internal 16-bit information is multiplexed to the low order data bus pins DB0 through DB7.

An internal oscillator provides a convenient source of frequencies for use as counter inputs. The oscillator's frequency is controlled at the X1 and X2 interface pins by an external reactive network such as a crystal. The oscillator output is divided by the Frequency Scaler to provide several sub-frequencies. One of the scaled frequencies (or one of ten input signals) may be selected as an input to the FOUT divider and then comes out of the chip at the FOUT interface pin.

The STC is addressed by the external system as two locations: a control port and a data port. The control port provides direct access to the Status and Command registers, as well as allowing the user to update the Data Pointer register. The data port is used to communicate with all other addressable internal locations. The Data Pointer register controls the data port addressing.

Among the registers accessible through the data port are the Master Mode register and five Counter Mode registers, one for each counter. The Master Mode register controls the programmable options that are not controlled by the Counter Mode registers.

Each of the five general-purpose counters is 16 bits long and is independently controlled by its Counter Mode register. Through this register, a user can software select one of 16 sources as the counter input, a variety of gating and repetition modes, up or down counting in binary or BCD and active-high or active-low input and output polarities.

Associated with each counter are a Load register and a Hold register, both accessible through the data port. The Load register is used to automatically reload the counter to any predefined value, thus controlling the effective count period. The Hold register is used to save count values without disturbing the count process, permitting the host processor to read intermediate counts. In addition, the Hold register may be used as a second Load register to generate a number of complex output waveforms.

All five counters have the same basic control logic and control registers. Counters 1 and 2 have additional Alarm registers and

comparators associated with them, plus the extra logic necessary for operating in a 24-hour time-of-day mode. For real-time operation the time-of-day logic will accept 50Hz, 60Hz or 100Hz input frequencies.

Each general counter has a single dedicated output pin. It may be turned off when the output is not of interest or may be configured in a variety of ways to drive interrupt controllers, Darlington buffers, bus drivers, etc. The counter inputs, on the other hand, are specifically not dedicated to any given interface line. Considerable versatility is available for configuring both the input and the gating of individual counters. This not only permits dynamic reassignment of inputs under software control, but also allows multiple counters to use a single input, and allows a single gate pin to control more than one counter. Indeed, a single pin can be the gate for one counter and, at the same time, the count source for another.

A powerful command structure simplifies user interaction with the counters. A counter must be armed by one of the ARM commands before counting can commence. Once armed, the counting process may be further enabled or disabled using the hardware gating facilities. The ARM and DISARM commands permit software gating of the count process in some modes.

The LOAD command causes the counter to be reloaded with the value in either the associated Load register or the associated Hold register. It will often be used as a software retrigger or as counter initialization prior to active hardware gating.

The DISARM command disables further counting independent of any hardware gating. A disarmed counter may be reloaded using the LOAD command, may be incremented or decremented using the STEP command and may be read using the SAVE command. A count process may be resumed using an ARM command.

The SAVE command transfers the contents of a counter to its associated Hold register. This command will overwrite any previous Hold register contents. The SAVE command is designed to allow an accumulated count to be preserved so that it can be read by the host CPU at some later time.

Two combinations of the basic commands exist to either LOAD AND ARM or to DISARM AND SAVE any combination of counters. Additional commands are provided to: step an individual counter by one count; set and clear an output toggle; issue a software reset; clear and set special bits in the Master Mode register; and load the Data Pointer register.

CONTROL PORT REGISTERS

The STC is addressed by the external system as only two locations: a Control port and a Data port. Transfers at the Control port ($C/\bar{D} = \text{High}$) allow direct access to the command register when writing and the status register when reading. All other available internal locations are accessed for both reading and writing via the Data port ($C/\bar{D} = \text{Low}$). Data port transfers are executed to and from the location currently addressed by the Data Pointer register. Options available in the Master Mode register and the Data Pointer control structure allow several types of transfer sequencing to be used. See Figure 7.

Transfers to and from the control port are always 8 bits wide. Each access to the Control port will transfer data between the Command register (writes) or Status register (reads) and Data Bus pins DB0-DB7, regardless of whether the Am9513 is in 8- or 16-bit bus mode. When the Am9513 is in 8-bit bus mode, Data Bus pins DB13-DB15 should be held at a logic high whenever \overline{CS} and \overline{WR} are both active.

Command Register

The Command register provides direct control over each of the five general counters and controls access through the Data port by allowing the user to update the Data Pointer register. The "Command Description" section of this data sheet explains the detailed operation of each command. A summary of all commands appears in Figure 21. Six of the command types are used for direct software control of the counting process. Each of these six commands contains a 5-bit S field. In a linear-select fashion, each bit in the S field corresponds to one of the five general counters ($S_1 = \text{Counter 1}$, $S_2 = \text{Counter 2}$, etc.). When an S bit is a one, the specified operation is performed on the counter so designated; when an S bit is a zero, no operation occurs for the corresponding counter.

Data Pointer Register

The 6-bit Data Pointer register is loaded by issuing the appropriate command through the control port to the Command register. As shown in Figure 7, the contents of the Data Pointer register are used to control the Data Port multiplexer, selecting which internal register is to be accessible through the Data Port.

The Data Pointer consists of a 3-bit Group Pointer, a 2-bit Element Pointer and a 1-bit Byte Pointer, depicted in Figure 8. The Byte Pointer bit indicates which byte of a 16-bit register is to be transferred on the next access through the data port. Whenever the Data Pointer is loaded, the Byte Pointer bit is set to one, indicating a least-significant byte is expected. The Byte Pointer toggles following each 8-bit data transfer with an 8-bit data bus ($MM13 = 0$), or it always remains set with the 16-bit data bus option ($MM13 = 1$). The Element and Group pointers are used to select which internal register is to be accessible through the Data Port. Although the contents of the Element and Group Pointer in the Data Pointer register cannot be read by the host processor, the Byte Pointer is available as a bit in the Status register.

Random access to any available internal data location can be accomplished by simply loading the Data Pointer using the command shown in Figure 9 and then initiating a data read or data write. This procedure can be used at any time, regardless of the setting of the Data Pointer Control bit ($MM14$). When the 8-bit data bus configuration is being used ($MM13 = 0$), two bytes of data would normally be transferred following the issuing of the "Load Data Pointer" command.

To permit the host processor to rapidly access the various internal registers, automatic sequencing of the Data Pointer is provided. Sequencing is enabled by clearing Master Mode bit 14 ($MM14$) to zero. As shown in Figure 10, several types of sequencing are available depending on the data bus width being used and the initial Data Pointer value entered by command.

When $E_1 = 0$ or $E_2 = 0$ and G_4, G_2, G_1 point to a Counter Group, the Data Pointer will proceed through the Element cycle. The Element field will automatically sequence through the three values 00, 01 and 10 starting with the value entered. When the transition from 10 to 00 occurs, the Group field will also be incremented by one. Note that the Element field in this case does not sequence to a value of 11. The Group field circulates only within the five Counter Group codes.

If $E_2, E_1 = 11$ and a Counter Group is selected, then only the Group field is sequenced. This is the Hold cycle. It allows the Hold registers to be sequentially accessed while bypassing the Mode and Load registers. The third type of sequencing is the Control

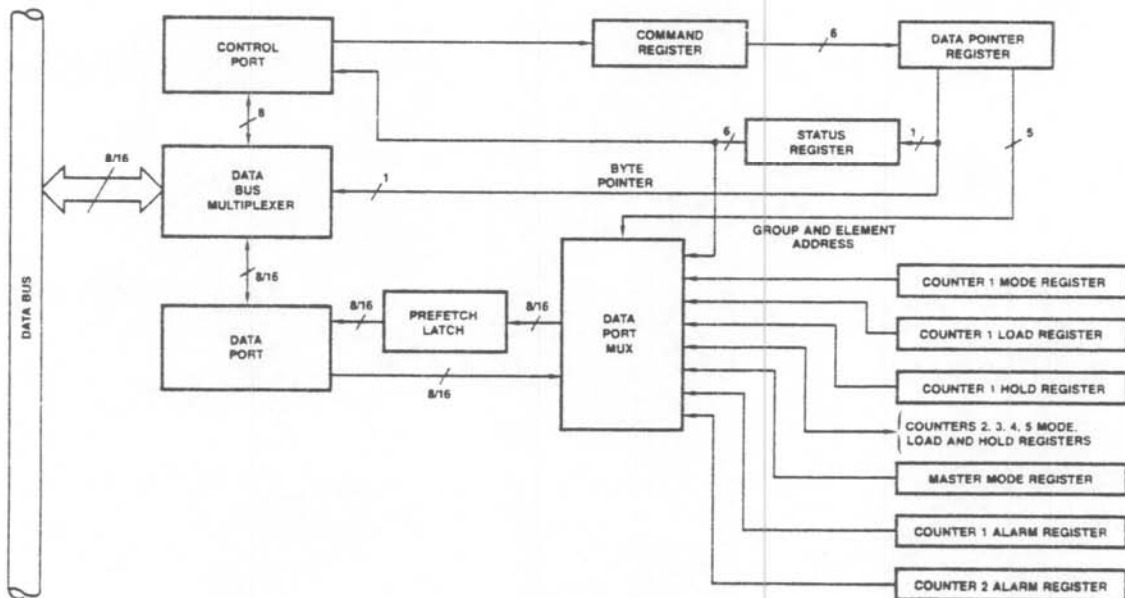

Figure 7. Am9513 Register Access.

MOS-501

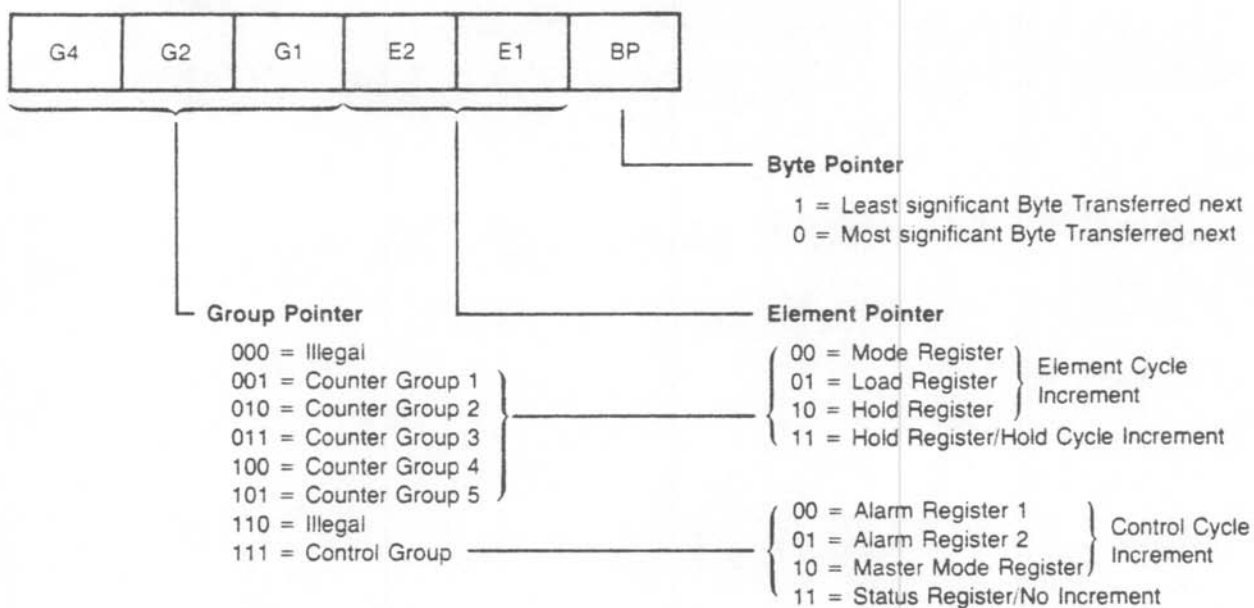

Figure 8. Data Pointer Register.

MOS-173

cycle. If G4, G2, G1 = 111 and E2, E1 ≠ 11, the Element Pointer will be incremented through the values 00, 01 and 10, with no change to the Group Pointer.

When G4, G2, G1 = 111 and E2, E1 = 11, no incrementing takes place and only the Status register will be available through the data port. Note that the Status register can also always be read directly through the Control port.

For all of these auto-sequence modes, if an 8-bit data bus is used, the Byte pointer will toggle after every data transfer to allow the least and most significant bytes to be transferred before the Element or Group Fields are incremented.

Prefetch Circuit

In order to minimize the read access time to internal Am9513 registers, a prefetch circuit is used for all read operations through the Data Port. Following each read or write operation through the Data Port, the Data Pointer register is updated to point to the next register to be accessed. Immediately following this update, the new register data is transferred to a special prefetch latch at the interface pad logic. When the user performs a subsequent read of the Data Port, the data bus drivers are enabled, outputting the prefetched data on the bus. Since the internal data register is accessed prior to the start of the read operation, its access time is transparent to the user. In order to keep the prefetched data consistent with the data pointer, prefetches are also performed after each write to the Data Port and after execution at the "Load Data Pointer" command. The following rules should be kept in mind regarding Data Port Transfers.

1. The Data Pointer register should always be reloaded before reading from the Data Port if a command other than "Load Data Pointer" was issued to the Am9513 following the last Data Port read or write. The Data Pointer does not have to be loaded again if the first Data Port transaction after a command entry is a write, since the Data Port write will automatically cause a new prefetch to occur.
2. Operating modes N, O, Q and R allow the user to save the counter contents in the Hold register by applying an active-going gate edge. If the Data Pointer register had been pointing to the Hold register in question, the prefetched value will not correspond to the new value saved in the Hold register. To

avoid reading an incorrect value, a new "Load Data Pointer" command should be issued before attempting to read the saved data. A Data Port write (to another register) will also initiate a prefetch; subsequent reads will access the recently saved Hold register data. Many systems will use the "saving" gate edge to interrupt the host CPU. In systems such as this the interrupt service routine should issue a "Load Data Pointer" command prior to reading the saved data.

Status Register

The 8-bit read-only Status register indicates the state of the Byte Pointer bit in the Data Pointer register and the state of the OUT signal for each of the general counters. See Figures 11 and 19. The OUT signals reported are those internal to the chip after the polarity-select logic and just before the 3-state interface buffer circuitry.

The Status register OUT bit reflects an active-high or active-low TC output, or a TC Toggled output, as programmed in the Output Control Field of the Counter Mode register. That is, it reflects the

	Element Cycle			Hold Cycle
	Mode Register	Load Register	Hold Register	Hold Register
Counter 1	FF01	FF09	FF11	FF19
Counter 2	FF02	FF0A	FF12	FF1A
Counter 3	FF03	FF0B	FF13	FF1B
Counter 4	FF04	FF0C	FF14	FF1C
Counter 5	FF05	FF0D	FF15	FF1D

Master Mode Register = FF17
 Alarm 1 Register = FF07
 Alarm 2 Register = FF0F

- Notes:
1. All codes are in hex.
 2. When used with an 8-bit bus, only the two low order hex digits should be written to the command port; the 'FF' prefix should be used only for a 16-bit data bus interface.

Figure 9. Load Data Pointer Commands.

exact state of the OUT pin. When the Low Impedance to Ground Output option (CM2-CM0 = 000) is selected, the Status register will reflect an active-high TC Output. When a High Impedance Output option (CM2-CM0 = 100) is selected, the Status register will reflect an active-low TC output.

For Counters 1 and 2, the OUT pin will reflect the comparator output if the comparators are enabled. The Status register bit and OUT pin are active high if CM2 = 0 and active-low if CM2 = 1. When the High Impedance option is selected and the comparator is enabled, the status register bit will reflect an active-high comparator output. When the Low Impedance to Ground option is selected and the comparator is enabled, the status register bit will reflect an active-low comparator output.

The Status register is normally accessed by reading the control port (see Figure 7) but may also be read via the data port as part of the Control Group.

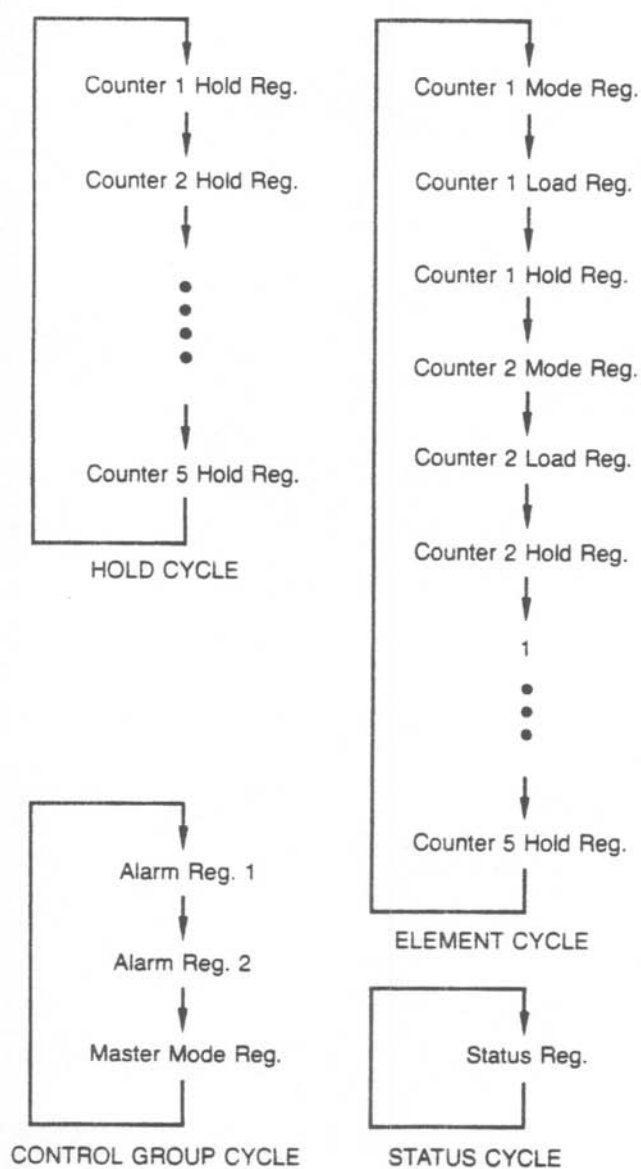

Figure 10. Data Pointer Sequencing.

MOS-174

DATA PORT REGISTERS

Counter Logic Groups

As shown in Figures 3 and 4, each of the five Counter Logic Groups consists of a 16-bit general counter with associated control and output logic, a 16-bit Load register, a 16-bit Hold register and a 16-bit Mode register. In addition, Counter Groups 1 and 2 also include 16-bit Comparators and 16-bit Alarm registers. The comparator/alarm functions are controlled by the Master Mode register. The operation of the Counter Mode registers is the same for all five counters. The host CPU has both read and write access to all registers in the Counter Logic Groups through the data port. The counter itself is never directly accessed.

The 16-bit read/write Load register is used to control the effective period of the general counter. Any 16-bit value may be written into the Load register. That value can then be transferred into the counter each time that Terminal Count (TC) occurs. "Terminal Count" is defined as that period of time when the counter contents would have been zero if an external value had not been transferred into the counter. Thus the terminal count frequency can be the input frequency divided by the value in the Load register. In all operating modes the contents of either Load or Hold register will be transferred into the counter when TC occurs. In cases where values are being accumulated in the counter, the Load register action can be transparent by filling the Load register with all zeros.

The 16-bit read/write Hold register is dual-purpose. It can be used in the same way as the Load register, thus offering an alternate source for modulo definition for the counter. The Hold register may also be used to store accumulated counter values for later transfer to the host processor. This allows the count to be sampled while the counting process proceeds. Transfer of the counter contents into the Hold register is accomplished by the hardware interface in some operating modes or by the software SAVE command at any time.

Counter Mode Register

The 16-bit read/write Counter Mode register controls the gating, counting, output and source select functions within each Counter Logic Group. The "Counter Mode Control Options" section of this data sheet describes the detailed control options available. Figure 18 shows the bit assignments for the Counter Mode registers.

Alarm Registers and Comparators

Added functions are available in the Counter Logic Groups for Counters 1 and 2 (see Figure 3). Each contains a 16-bit Alarm register and a 16-bit Comparator. When the value in the counter reaches the value in the Alarm register, the Comparator output will go true. The Master Mode register contains control bits to individually enable/disable the comparators. When enabled, the

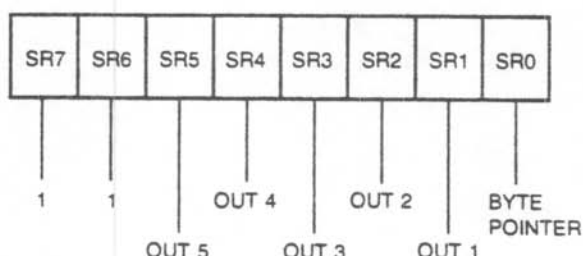

Figure 11. Status Register Bit Assignments.

MOS-175

comparator output appears on the OUT pin of the associated counter in place of the normal counter output. The output will remain true as long as the comparison is true, that is, until the next input causes the count to change. The polarity of the Comparator output will be active-high if the Output Control field of the Counter Mode register is 001 or 010 and active-low if the Output Control field is 101.

REGISTER ACCESS

Information Transfer Protocols

The control signal configurations for all information transfers on the Am9513 data bus are summarized in Figure 12. The interface control logic assumes these conventions:

1. \overline{RD} and \overline{WR} are never active at the same time.
2. \overline{RD} , \overline{WR} and C/\overline{D} are ignored unless \overline{CS} is Low.

Command Initiation

The procedure for executing a command is as follows:

1. Establish the appropriate command on the DB0-DB7 lines. Figure 21 lists the command codes. When using the Am9513 in 16-bit mode, data bus lines DB8-DB15 should be set high during the write operation. In 8-bit data bus mode, DB13-DB15 should be set high during the write operation.
2. Establish a High on the C/\overline{D} input.
3. Establish a Low on the \overline{CS} input.
4. Establish a Low on the \overline{WR} input.
5. Sometime after the minimum \overline{WR} low pulse duration has been achieved, drive \overline{WR} high, taking care the \overline{CS} , C/\overline{D} and data setup times are met (see Timing Diagram).
6. After meeting the required \overline{CS} , C/\overline{D} and data hold times, these signals can be changed (see Timing Diagram).

A new read or write operation to the Am9513 should not be performed until the write recovery time is met (see Timing Diagram).

Setting the Data Pointer Register

The Data Pointer register selects which register is to be accessed through the data port. The Pointer is set as follows:

1. Using Figures 8 and 9, select the appropriate Data Pointer Group and Element codes for the register to be accessed. Note that two codes are provided for the Hold registers, to accommodate both the Hold Cycle and Element Cycle auto-sequencing modes shown in Figure 10. If auto-sequencing is disabled, either Hold code may be used.

Signal Configuration				Data Bus Operation
\overline{CS}	C/\overline{D}	\overline{RD}	\overline{WR}	
0	0	0	1	Transfer contents of register addressed by Data Pointer to the data bus.
0	0	1	0	Transfer contents of data bus to data register addressed by Data Pointer.
0	1	0	1	Transfer contents of Status register to data bus.
0	1	1	0	Transfer contents of data bus into Command register.
X	X	1	1	No transfer.
1	X	X	X	No transfer.
X	X	0	0	Illegal Condition.

Figure 12. Data Bus Transfers.

2. Using the "Writing to the Command Register" procedure given above, write the appropriate "Load Data Pointer" command to the Command register. Note that the command summary in Figure 21 has the Group field and Element field switched from the format given in Figure 8.

The Data Pointer register is now set. Setting the Data Pointer register automatically sets the Byte Pointer to 1, indicating a least significant byte is expected for 8-bit data bus interfacing. If Master Mode register bit MM14 = 0, the Data Pointer will automatically sequence through one of the cycles shown in Figure 10 after reading or writing each register. For convenience, bit MM14 can be set or cleared by software command.

Reading the Status Register

The procedure for reading the Status register through the Control port is given in the following. The Status register can also be read from the data port as outlined in the Reading from the Data Port section of this data sheet.

1. Establish a High on the C/\overline{D} input.
2. Establish a Low on the \overline{CS} input.
3. After the appropriate \overline{CS} and C/\overline{D} setup time (see Timing Diagram) make \overline{RD} Low.
4. Sometime after \overline{RD} goes Low, the Status register contents will appear on the data bus. These lines will contain the information as long as \overline{RD} is Low. If the state of an OUT pin changes while \overline{RD} is Low, this will be reflected by a change in the information on the data bus.
5. \overline{RD} can be driven High to conclude the read operation after meeting the minimum \overline{RD} pulse duration.
6. \overline{CS} and C/\overline{D} can change after meeting the appropriate hold time requirements (see Timing Diagram).

A new read or write operation to the Am9513 should not be attempted until the read recovery time is met (see Timing Diagram).

Writing to the Data Port

The registers which can be written to through the data port are the Load, Hold and Counter Mode registers for Counters 1 through 5, the Alarm registers for Counters 1 and 2 and the Master Mode register. The procedure for writing to these three registers is as follows:

1. Prior to performing the actual write operation, the Data Pointer should be set to point to the register to be written to, as outlined above in the "Setting the Data Pointer" section of this data sheet. In cases where auto-sequencing of the Data Pointer is used, the Pointer has to be set only once to the first register in the sequence. When auto-sequencing is disabled, repetitive accesses can be made to the same register without reloading the Data Pointer each time.
2. Establish the appropriate data on the DB0-DB7 lines (8-bit bus mode) or DB0-DB15 (16-bit bus mode). When using the 8-bit bus mode, data bus lines DB13-DB15 should be set High during the write operation and DB0-DB7 should be set to the lower data byte for the first write and to the upper data byte for the second write.
3. Establish a Low on the C/\overline{D} input.
4. Establish a Low on the \overline{CS} input.
5. Establish a Low on the \overline{WR} input.
6. Drive \overline{WR} High sometime after the minimum \overline{WR} low pulse duration has been achieved, taking care the \overline{CS} , C/\overline{D} and data setup times are met (see Timing Diagram).
7. After meeting the required \overline{CS} , C/\overline{D} and data hold times, these signals can be changed (see Timing Diagram).
8. After meeting the write recovery time (see Timing Diagram) a new read or write operation can be performed. For the 8-bit bus mode, steps 2 through 7 should be repeated, this time

placing the high data byte on pins DB0-DB7. The user is not required to drive \overline{CS} or C/\overline{D} High between successive reads or writes, although this is permissible.

Reading From the Data Port

The registers which can be read from the Data port are the Load, Hold and Counter Mode registers for Counters 1 through 5, the Alarm registers for Counters 1 and 2, the Master Mode register and the Status register. The Status register can also be read from the Control port. The procedure for reading these registers is as follows:

1. Prior to performing the actual read operation, the Data Pointer should be set to point to the register to be read, as outlined in the "Settling the Data Pointer" section of this data sheet. In cases where auto-sequencing of the Data Pointer is used, the Pointer has to be set only once to the first register in the sequence. When auto-sequencing is disabled, repetitive accesses can be made to the same register without reloading the Data Pointer each time. Special care must be taken to reset the Data Pointer after issuing a command other than "Load Data Pointer" to the Am9513 or when operating a counter in modes N, O, Q or R. See the "Prefetch Circuit" section of this document for elaboration.
2. Establish a Low on the C/\overline{D} input.
3. Establish a Low on the \overline{CS} input.
4. Establish a Low on \overline{RD} after waiting for the appropriate \overline{CS} and C/\overline{D} setup time (see Timing Diagram).
5. Sometime after \overline{RD} goes Low, the register contents will appear on the data bus. In both 8- and 16-bit bus modes the low register byte will appear on DB0-DB7. In addition, in 16-bit bus mode, the upper register byte will appear on DB8-DB15. For 8-bit bus mode, pins DB8-DB15 are not driven by the Am9513.

This information will remain stable as long as \overline{RD} is Low. If the register value is changed during the read, the change will not be reflected by a change in the data being read, for the reasons outlined in the "Prefetch Circuit" section of this document.

6. \overline{RD} can be driven High to conclude the read operation after meeting the minimum \overline{RD} pulse duration.
7. \overline{CS} and C/\overline{D} can change after meeting appropriate hold time requirements (see Timing Diagram).
8. After waiting the minimum read recovery time (see Timing Diagram), a new read or write operation can be started. For 8-bit bus mode, steps 2 through 7 should be repeated to read out the high register byte on DB0-DB7. (If the Status register is being read in 8-bit mode, the two reads will return the Status register each time. In 16-bit mode, reads from the Status register return undefined data on DB8-DB15.) The user is not required to drive \overline{CS} or C/\overline{D} High between successive reads or writes, although this is permissible.

MASTER MODE CONTROL OPTIONS

The 16-bit Master Mode (MM) register is used to control those internal activities that are not controlled by the individual Counter Mode registers. This includes frequency control, time-of-day operation, comparator controls, data bus width and data pointer sequencing. Figure 13 shows the bit assignments for the Master Mode register. This section describes the use of each control field.

Master Mode register bits MM12, MM13 and MM14 can be individually set and reset using commands issued to the Command register. In addition they can all be changed by writing directly to the Master Mode register.

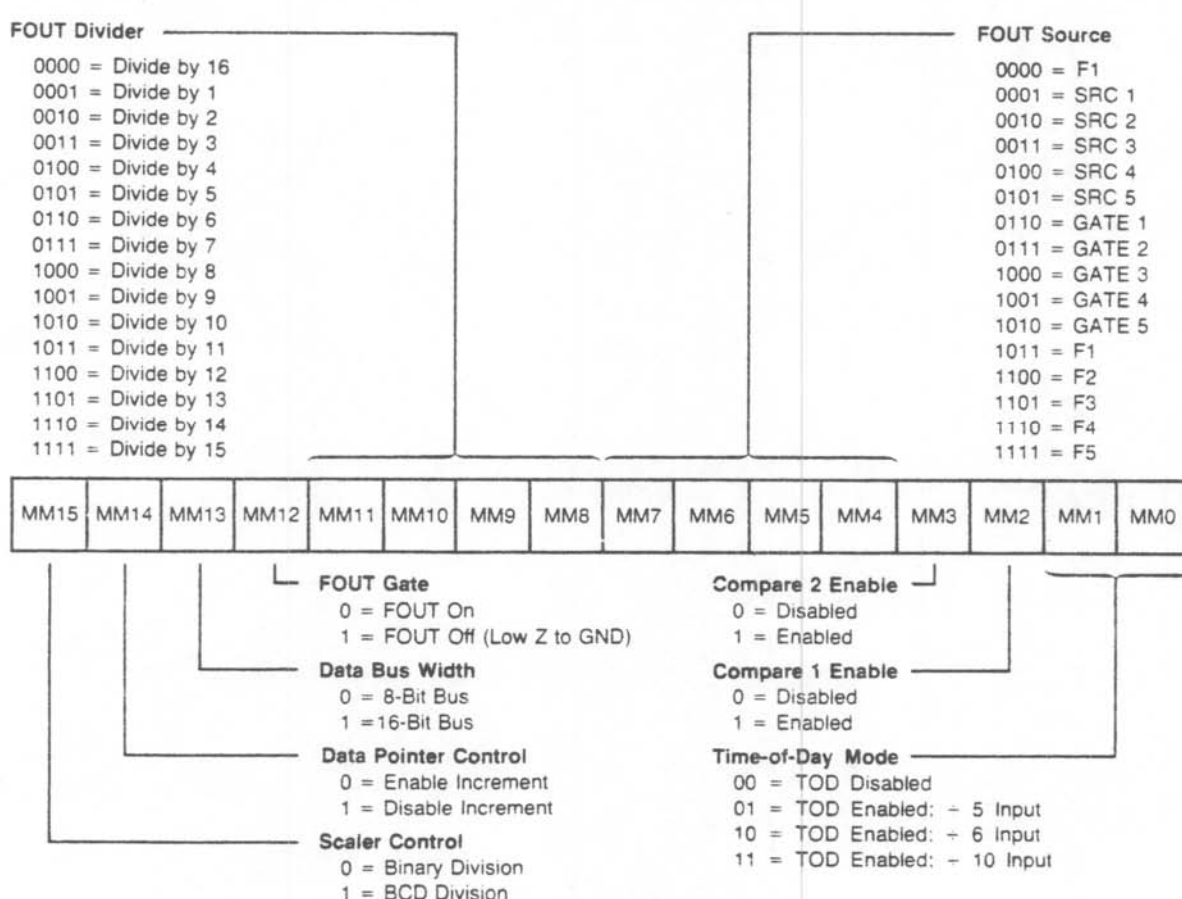

Figure 13. Master Mode Register Bit Assignments.

MOS-180

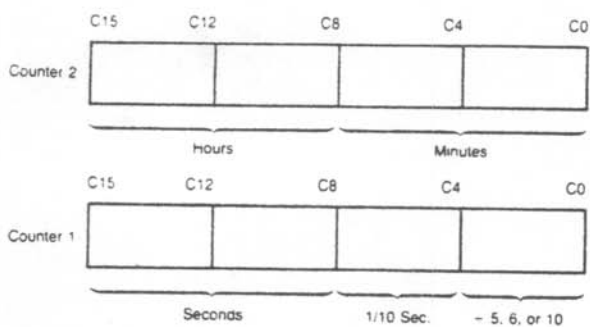

Figure 14. Time-of-Day Storage Configuration.

After power-on reset or a Master Reset command, the Master Mode register is cleared to an all zero condition. This results in the following configuration:

- Time-of-day disabled
- Both Comparators disabled
- FOUT Source is frequency F1
- FOUT Divider set for divide-by-16
- FOUT gated on
- Data Bus 8 bits wide
- Data Pointer Sequencing enabled
- Frequency Scaler divides in binary

Time-of-Day

Bits MM0 and MM1 of the Master Mode register specify the time-of-day (TOD) options. When MM0 = 0 and MM1 = 0, the special logic used to implement TOD is disabled and Counters 1 and 2 will operate in exactly the same way as Counters 3, 4 and 5. When MM0 = 1 or MM1 = 1, additional counter decoding and control logic is enabled on Counters 1 and 2 which causes their decodes to turn over at the counts that generate appropriate 24-hour TOD accumulations.

Figure 14 shows the counter configurations for TOD operation. The two most significant decades of Counter 2 contain the "hours" digits and they can hold a maximum count of 23 hours. The two least significant decades of Counter 2 indicate "minutes" and will hold values up to 59. The three most significant decades of Counter 1 indicate "seconds" and will contain values up to 59.9. The least significant decade of Counter 1 is used to scale the input frequency in order to output tenth-of-second periods into the next decade. It can be set up to divide-by-five (MM0 = 1, MM1 = 0), divide-by-six (MM0 = 0, MM1 = 1), or divide-by-ten (MM0 = 1, MM1 = 1). The input frequency, therefore, for real-time clock-

ing can be, respectively, 50Hz, 60Hz or 100Hz. With divide-by-ten specified and with 100Hz input, the least significant decade of Counter 1 accumulates time in hundredths of seconds (tens of milliseconds). For accelerated time applications other input frequencies may be useful.

The input for Counter 2 should be the TC output of Counter 1, connected either internally or externally, for TOD operation. Both counters should be set up for BCD counting. The Load registers should be used to initialize the counters to the proper time. Either count up or count down may be used.

To read the time, a SAVE command should be issued to Counters 1 and 2. Because counts ripple between the counters, the possibility exists of the SAVE command occurring after Counter 1 has counted but before Counter 2 has. This would result in an incorrectly saved time. To guard against this, Counter 2 should be resaved if Counter 1's saved value indicates a ripple carry/borrow may have been generated. In other words, Counter 2 should be resaved if the value saved from Counter 1 is 0 (up counting), 59.94 (down counting, MM1-MM0 = 01), 59.95 (down counting, MM1-MM0 = 10), or 59.99 (down counting, MM1-MM0 = 11). By the time this test is performed and Counter 2 is resaved, any rippling carry/borrow will have updated Counter 2.

Comparator Enable

Bits MM2 and MM3 control the Comparators associated with Counter 1 and 2. When a Comparator is enabled, its output is substituted for the normal counter output on the associated OUT1 or OUT2 pin. The comparator output will be active-high if the output control field of the Counter Mode register is 001 or 010 and active low for a code of 101. Once the compare output is true, it will remain so until the count changes and the comparison therefore goes false.

The two Comparators can always be used individually in any operating mode. One special case occurs when the time-of-day option is invoked and both Comparators are enabled. The operation of Comparator 2 will then be conditioned by Comparator 1 so that a full 32-bit compare must be true in order to generate a true signal on OUT2. OUT1 will continue, as usual, to reflect the state of the 16-bit comparison between Alarm 1 and Counter 1.

FOUT Source

Master Mode bits MM4 through MM7 specify the source input for the FOUT divider. Fifteen inputs are available for selection and they include the five Source pins, the five Gate pins and the five internal frequencies derived from the oscillator. The 16th combination of the four control bits (all zeros) is used to assure that an active frequency is available at the input to the FOUT divider following reset.

FOUT Divider

Bits MM8 through MM11 specify the dividing ratio for the FOUT Divider. The FOUT source (selected by bits MM4 through MM7) is divided by an integer value between 1 and 16, inclusive, and is then passed to the FOUT output buffer. After power-on or reset, the FOUT divider is set to divide-by-16.

FOUT Gate

Master Mode bit MM12 provides a software gating capability for the FOUT signal. When MM12 = 1, FOUT is off and in a low impedance state to ground. MM12 may be set or cleared in conjunction with the loading of the other bits in the Master Mode register; alternatively, there are commands that allow MM12 to be individually set or cleared directly without changing any other Master Mode bits. After power-up or reset, FOUT is gated on.

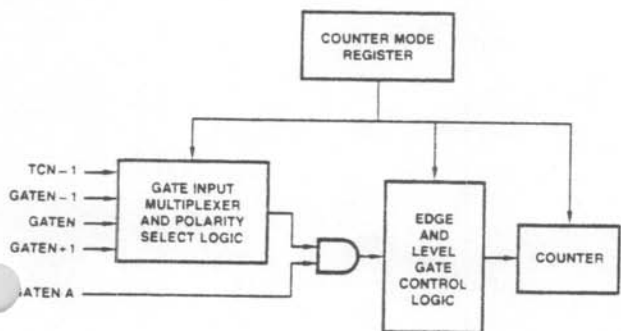

Figure 15. Gating Control.

When changing the FOUT divider ratio or FOUT source, transient pulses as short as half the period of the FOUT source may appear on the FOUT pin. Turning the FOUT gate on or off can also generate a transient. This should be considered when using FOUT as a system clock source.

Bus Width

Bit MM13 controls the multiplexer at the data bus interface in order to configure the part for an 8-bit or 16-bit external bus. The internal bus is always 16 bits wide. When MM13 = 1, 16-bit data is transferred directly between the internal bus and all 16 of the external bus lines. In this configuration, the Byte Pointer bit in the Data Pointer register remains set at all times. When MM13 = 0, 16-bit internal data is transferred a byte at a time to and from the eight low-order external data bus lines. The Byte Pointer bit toggles with each byte transfer in this mode.

When the Am9513 is set to operate with an 8-bit data bus width, pins DB8 through DB15 are not used for the data bus and are available for other functions. Pins DB13 through DB15 should be tied high. Pins DB8 through DB12 are used as auxiliary gating inputs, and are labeled GATE1A through GATE5A respectively. The auxiliary gate pin, GATENA, is logically ANDed with the gate input to Counter N, as shown in Figure 15. The output of the AND gate is then used as the gating signal for Counter N.

Data Pointer Sequencing

Bit MM14 controls the Data Pointer logic to enable or disable the automatic sequencing functions. When MM14 = 1, the contents of the Data Pointer can be changed only directly by entering a command. When MM14 = 0, several types of automatic sequencing of the Data Pointer are available. These are described in the Data Pointer register section of this document.

Thus the host processor, by controlling MM14, may repetitively read/write a single internal location, or may sequentially read/write groups of locations. Bit MM14 can be loaded by writing to the Master Mode register or can be set or cleared by software command.

Scaler Ratios

Master Mode bit MM15 controls the counting configuration of the Frequency Scaler counter. When MM15 = 0, the Scaler divides

the oscillator frequency in binary steps so that each sub-frequency is 1/16 of the preceding frequency. When MM15 = 1, the Scaler divides in BCD steps so that adjacent frequencies are related by ratios of 10 instead of 16 (see Figure 16).

OPERATING MODE DESCRIPTIONS

Counter Mode register bits CM15-CM13 and CM7-CM5 select the operating mode for each counter (see Figure 17). To simplify references to a particular mode, each mode is assigned a letter from A through X.

To keep the following mode descriptions concise and to the point, the phrase "source edges" is used to refer to active-going source edges only, not to inactive-going edges. Similarly, the phrase "gate edges" refers only to active-going gate edges. Also, again to avoid verbosity and euphuism, the descriptions of some modes states that a counter is stopped or disarmed "on a TC, inhibiting further counting." As is fully explained in the TC section of this data sheet, for these modes the counter is actually stopped or disarmed following the active-going source edge which drives the counter out of TC. In other words, since a counter in the TC state always counts, irrespective of its gating or arming status, the stopping or disarming of the count sequence is delayed until TC is terminated.

MODE A

Software-Triggered Strobe with No Hardware Gating

Mode A is one of the simplest operating modes. The counter will be available for counting source edges when it is issued an ARM command. On each TC the counter will reload from the Load register and automatically disarm itself, inhibiting further counting. Counting will resume when a new ARM command is issued.

MODE B

Software-Triggered Strobe with Level Gating

Mode B is identical to Mode A except that source edges are counted only when the assigned Gate is active. The counter must be armed before counting can occur. Once armed, the counter will count all source edges which occur while the Gate is active and disregard those edges which occur while the Gate is inactive.

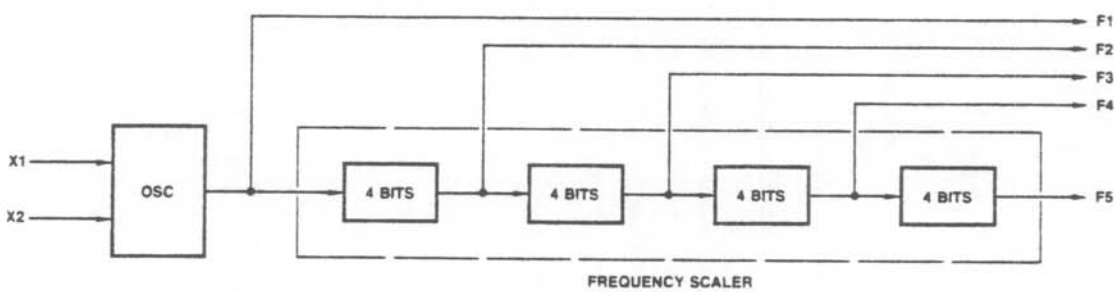

Frequency	BCD Scaling MM15 = 1	Binary Scaling MM15 = 0
F1	OSC	OSC
F2	$F1 \div 10$	$F1 \div 16$
F3	$F1 \div 100$	$F1 \div 256$
F4	$F1 \div 1,000$	$F1 \div 4,096$
F5	$F1 \div 10,000$	$F1 \div 65,536$

Figure 16. Frequency Scaler Ratios.

MOS-150

Operating Mode	A	B	C	D	E	F	G	H	I	J	K	L
Special Gate (CM7)	0	0	0	0	0	0	0	0	0	0	0	0
Reload Source (CM6)	0	0	0	0	0	0	1	1	1	1	1	1
Repetition (CM5)	0	0	0	1	1	1	0	0	0	1	1	1
Gate Control (CM15-CM13)	000	LEVEL	EDGE	000	LEVEL	EDGE	000	LEVEL	EDGE	000	LEVEL	EDGE
Count to TC once, then disarm	X	X	X									
Count to TC twice, then disarm							X	X	X			
Count to TC repeatedly				X	X	X				X	X	X
Gate input does not gate counter input	X			X			X			X		
Count only during active gate level		X			X			X			X	
Start count on active gate edge and stop count on next TC.			X			X						
Start count on active gate edge and stop count on second TC.									X			X
No hardware retriggering	X	X	X	X	X	X	X	X	X	X	X	X
Reload counter from Load Register on TC	X	X	X	X	X	X						
Reload counter on each TC, alternating reload source between Load and Hold Registers.							X	X	X	X	X	X
Transfer Load Register into counter on each TC that gate is LOW; transfer Hold Register into counter on each TC that gate is HIGH.												
On active gate edge transfer counter into Hold Register and then reload counter from Load Register.												

Operating Mode	M	N	O	P	Q	R	S	T	U	V	W	X
Special Gate (CM7)	1	1	1	1	1	1	1	1	1	1	1	1
Reload Source (CM6)	0	0	0	0	0	0	1	1	1	1	1	1
Repetition (CM5)	0	0	0	1	1	1	0	0	0	1	1	1
Gate Control (CM15-CM13)	000	LEVEL	EDGE	000	LEVEL	EDGE	000	LEVEL	EDGE	000	LEVEL	EDGE
Count to TC once, then disarm		X	X									
Count to TC twice, then disarm							X					
Count to TC repeatedly					X	X				X		
Gate input does not gate counter input							X			X		
Count only during active gate level		X			X							
Start count on active gate edge and stop count on next TC.			X			X						
Start count on active gate edge and stop count on second TC.												
No hardware retriggering							X			X		
Reload counter from Load Register on TC		X	X		X	X						
Reload counter on each TC, alternating reload source between Load and Hold Registers.												
Transfer Load Register into counter on each TC that gate is LOW; transfer Hold Register into counter on each TC that gate is HIGH.							X			X		
On active gate edge transfer counter into Hold Register and then reload counter from Load Register.		X	X		X	X						

Note: Operating modes M, P, T, U, W and X are reserved and should not be used.

Figure 17. Counter Control Interaction.

This permits the Gate to turn the count process on and off. On each TC the counter will reload from the Load register and automatically disarm itself, inhibiting further counting until a new ARM command is issued.

MODE C **Hardware-Triggered Strobe**

Mode C is identical to Mode A, except that counting will not begin until a Gate edge is applied to the armed counter. The counter must be armed before application of the triggering Gate edge; Gate edges applied to a disarmed counter are disregarded. The counter will start counting on the first source edge after the triggering Gate edge and will continue counting until TC. At TC, the counter will reload from the Load register and automatically disarm itself. Counting will then remain inhibited until a new ARM command and a new Gate edge are applied in that order. Note that after application of a triggering Gate edge, the Gate input will be disregarded for the remainder of the count cycle. This differs from Mode B, where the Gate can be modulated throughout the count cycle to stop and start the counter.

MODE D **Rate Generator with No Hardware Gating**

Mode D is typically used in frequency generation applications. In this mode, the Gate input does not affect counter operation. Once armed, the counter will count to TC repetitively. On each TC the counter will reload itself from the Load register; hence the Load register value determines the time between TCs. A square wave rate generator may be obtained by specifying the TC Toggled output mode in the Counter Mode register.

MODE E **Rate Generator with Level Gating**

Mode E is identical to Mode D, except the counter will only count those source edges which occur while the Gate input is active. This feature allows the counting process to be enabled and disabled under hardware control. A square wave rate generator may be obtained by specifying the TC Toggled output mode.

MODE F **Non-Retriggerable One-Shot**

Mode F provides a non-retriggerable one-shot timing function. The counter must be armed before it will function. Application of a Gate edge to the armed counter will enable counting. When the counter reaches TC, it will reload itself from the Load register. The counter will then stop counting, awaiting a new Gate edge. Note that unlike Mode C, a new ARM command is not needed after TC, only a new Gate edge. After application of a triggering Gate edge, the Gate input is disregarded until TC.

MODE G **Software-Triggered Delayed Pulse One-Shot**

In Mode G, the Gate does not affect the counter's operation. Once armed, the counter will count to TC twice and then automatically disarm itself. For most applications, the counter will initially be loaded from the Load register either by a LOAD command or by the last TC of an earlier timing cycle. Upon counting to the first TC, the counter will reload itself from the Hold register. Counting will proceed until the second TC, when the counter will reload itself from the Load register and automatically disarm itself, inhibiting further counting. Counting can be resumed by issuing a new ARM command. A software-triggered delayed pulse one-shot may be generated by specifying the TC Toggled output mode in the Counter Mode register. The initial counter contents control the delay from the ARM command until the output pulse starts. The Hold register contents control the pulse duration.

MODE H **Software-Triggered Delayed Pulse One-Shot with Hardware Gating**

Mode H is identical to Mode G except that the Gate input is used to qualify which source edges are to be counted. The counter must be armed for counting to occur. Once armed, the counter will count all source edges that occur while the Gate is active and disregard those source edges that occur while the Gate is inactive. This permits the Gate to turn the count process on and off. As with Mode G, the counter will be reloaded from the Hold register on the first TC and reloaded from the Load register and disarmed on the second TC. This mode allows the Gate to control the extension of both the initial output delay time and the pulse width.

MODE I **Hardware-Triggered Delayed Pulse Strobe**

Mode I is identical to Mode G, except that counting will not begin until a Gate edge is applied to an armed counter. The counter must be armed before application of the triggering Gate edge; Gate edges applied to a disarmed counter are disregarded. An armed counter will start counting on the first source edge after the triggering Gate edge. Counting will then proceed in the same manner as in Mode G. After the second TC, the counter will disarm itself. An ARM command and Gate edge must be issued in this order to restart counting. Note that after application of a triggering Gate edge, the Gate input will be disregarded until the second TC. This differs from Mode H, where the Gate can be modulated throughout the count cycle to stop and start the counter.

MODE J **Variable Duty Cycle Rate Generator with No Hardware Gating**

Mode J will find the greatest usage in frequency generation applications with variable duty cycle requirements. Once armed, the counter will count continuously until it is issued a DISARM command. On the first TC, the counter will be reloaded from the Hold register. Counting will then proceed until the second TC at which time the counter will be reloaded from the Load register. Counting will continue, with the reload source alternating on each TC, until a DISARM command is issued to the counter. (The third TC reloads from the Hold register, the fourth TC reloads from the Load register, etc.) A variable duty cycle output can be generated by specifying the TC Toggled output in the Counter Mode register. The Load and Hold values then directly control the output duty cycle, with high resolution available when relatively high count values are used.

MODE K **Variable Duty Cycle Rate Generator with Level Gating**

Mode K is identical to Mode J except that source edges are only counted when the Gate is active. The counter must be armed for counting to occur. Once armed, the counter will count all source edges which occur while the Gate is active and disregard those source edges which occur while the Gate is inactive. This permits the Gate to turn the count process on and off. As with Mode J, the reload source used will alternate on each TC, starting with the Hold register on the first TC after any ARM command. When the TC Toggled output is used, this mode allows the Gate to modulate the duty cycle of the output waveform. It can affect both the high and low portions of the output waveform.

MODE L **Hardware-Triggered Delayed Pulse One-Shot**

Mode L is similar to Mode J except that counting will not begin until a Gate edge is applied to an armed counter. The counter must be armed before application of the triggering Gate edge;

Gate edges applied to a disarmed counter are disregarded. The counter will start counting source edges after the triggering Gate edge and counting will proceed until the second TC. Note that after application of a triggering Gate edge, the Gate input will be disregarded for the remainder of the count cycle. This differs from Mode K, where the gate can be modulated throughout the count cycle to stop and start the counter. On the first TC after application of the triggering Gate edge, the counter will be reloaded from the Hold register. On the second TC, the counter will be reloaded from the Load register and counting will stop until a new gate edge is issued to the counter. Note that unlike Mode K, new Gate edges are required after every second TC to continue counting.

MODE N

Software-Triggered Strobe with Level Gating and Hardware Retriggering

Mode N provides a software-triggered strobe with level gating that is also hardware retriggerable. The counter must first be issued an ARM command before counting can occur. Once armed, the counter will count all source edges which occur while the gate is active and disregard those source edges which occur while the Gate is inactive. This permits the Gate to turn the count process on and off. After the issuance of an ARM command and the application of an active Gate, the counter will count to TC. Upon reaching TC, the counter will reload from the Load register and automatically disarm itself, inhibiting further counting. Counting will resume upon the issuance of a new ARM command. All active-going Gate edges issued to an armed counter will cause a retrigger operation. Upon application of the Gate edge, the counter contents will be saved in the Hold register. On the first qualified source edge after application of the retriggering gate edge the contents of the Load register will be transferred into the counter. Counting will resume on the second qualified source edge after the retriggering Gate edge. Qualified source edges are active-going edges which occur while the Gate is active.

MODE O

Software-Triggered Strobe with Edge Gating and Hardware Retriggering

Mode O is similar to Mode N, except that counting will not begin until an active-going Gate edge is applied to an armed counter and the Gate level is not used to modulate counting. The counter must be armed before application of the triggering Gate edge; Gate edges applied to a disarmed counter are disregarded. Irrespective of the Gate level, the counter will count all source edges after the triggering Gate edge until the first TC. On the first TC the counter will be reloaded from the Load register and disarmed. A new ARM command and a new Gate edge must be applied in that order to initiate a new counting cycle. Unlike Modes C, F, I and L, which disregard the Gate input once counting starts, in Mode O the count process will be retriggered on all active-going Gate edges, including the first Gate edge used to start the counter. On each retriggering Gate edge, the counter contents will be transferred into the Hold register. On the first source edge after the retriggering Gate edge the Load register contents will be transferred into the counter. Counting will resume on the second source edge after a retrigger.

MODE Q

Rate Generator with Synchronization (Event Counter with Auto-Read/Reset)

Mode Q provides a rate generator with synchronization or an event counter with auto-read/reset. The counter must first be issued an ARM command before counting can occur. Once armed, the counter will count all source edges which occur while

the Gate is active and disregard those edges which occur while the Gate is inactive. This permits the Gate to turn the count process on and off. After the issuance of an ARM command and the application of an active Gate, the counter will count to TC repetitively. On each TC the counter will reload itself from the Load register. The counter may be retriggered at any time by presenting an active-going Gate edge to the Gate input. The retriggering Gate edge will transfer the contents of the counter into the Hold register. The first qualified source edge after the retriggering Gate edge will transfer the contents of the Load register into the counter. Counting will resume on the second qualified source edge after the retriggering gate edge. Qualified source edges are active-going edges which occur while the Gate is active.

MODE R

Retriggerable One-Shot

Mode R is similar to Mode Q, except that edge gating rather than level gating is used. In other words, rather than use the Gate level to qualify which source edges to count, Gate edges are used to start the counting operation. The counter must be armed before application of the triggering Gate edge; Gate edges applied to a disarmed counter are disregarded. After application at a Gate edge, an armed counter will count all source edges until TC, irrespective of the Gate level. On the first TC the counter will be reloaded from the Load register and stopped. Subsequent counting will not occur until a new Gate edge is applied. All Gate edges applied to the counter, including the first used to trigger counting, initiate a retrigger operation. Upon application of a Gate edge, the counter contents are saved in the Hold register. On the first source edge after the retriggering Gate edge, the Load register contents will be transferred into the counter. Counting will resume on the second source edge after the retriggering Gate edge.

MODE S

In this mode, the reload source for LOAD commands (irrespective of whether the counter is armed or disarmed) and for TC-initiated reloads is determined by the Gate input. The Gate input in Mode S is used only to select the reload source, not to start or modulate counting. When the Gate is Low, the Load register is used; when the Gate is High, the Hold register is used. Note the Low-Load, High-Hold mnemonic convention. Once armed, the counter will count to TC twice and then disarm itself. On each TC the counter will be reloaded from the reload source selected by the Gate. Following the second TC, an ARM command is required to start a new counting cycle.

MODE V

Frequency-Shift Keying

Mode V provides frequency-shift keying modulation capability. Gate operation in this mode is identical to that in Mode S. If the Gate is Low, a LOAD command or a TC-induced reload will reload the counter from the Load register. If the Gate is High, LOADs and reloads will occur from the Hold register. The polarity of the Gate only selects the reload source; it does not start or modulate counting. Once armed, the counter will count repetitively to TC. On each TC the counter will reload itself from the register determined by the polarity of the Gate. Counting will continue in this manner until a DISARM command is issued to the counter. Frequency shift keying may be obtained by specifying a TC Toggled output mode in the Counter Mode register. The switching of frequencies is achieved by modulating the Gate.

COUNTER MODE CONTROL OPTIONS

Each Counter Logic Group includes a 16-bit Counter Mode (CM) register used to control all of the individual options available with its associated general counter. These options include output configuration, count control, count source and gating control. Figure 18 shows the bit assignments for the Counter Mode registers. This section describes the control options in detail. Note that generally each counter is independently configured and does not depend on information outside its Counter Logic Group. The Counter Mode register should be loaded only when the counter is Disarmed. Attempts to load the Counter Mode register when the counter is armed may result in erratic counter operation.

After power-on reset or a Master Reset command, the Counter Mode registers are initialized to a preset condition. The value entered is 0B00 hex and results in the following control configuration:

- Output low impedance to ground
- Count down
- Count binary
- Count once
- Load register selected
- No retriggering
- F1 input source selected
- Positive-true input polarity
- No gating

Output Control

Counter mode bits CM0 through CM2 specify the output control configuration. Figure 19 shows a schematic representation of the output control logic. The OUT pin may be off and in a high impedance state, or it may be off with a low impedance to ground. The three remaining valid combinations represent the two basic output waveforms.

One output form available is called Terminal Count (TC) and represents the period in time that the counter reaches an equivalent value of zero. TC will occur on the next count when the counter is at 0001 for down counting, at 9999 (BCD) for BCD up counting or at FFFF (hex) for binary up counting. Figure 20 shows a Terminal Count pulse and an example context that generated it. The TC width is determined by the period of the counting source. Regardless of any gating input or whether the counter is Armed or Disarmed, the terminal count will go active for only one clock cycle. Figure 20 assumes active-high source polarity, counter armed, counter decrementing and an external reload value of K.

The counter will always be loaded from an external location when TC occurs; the user can choose the source location and the value. If a non-zero value is picked, the counter will never really attain a zero state and TC will indicate the counter state that would have been zero had no parallel transfer occurred.

The other output form, TC Toggled, uses the trailing edge of TC to toggle a flip-flop to generate an output level instead of a pulse.

Count Source Selection

- 0XXXX = Count on Rising Edge
- 1XXXX = Count on Falling Edge
- X0000 = TCN-1
- X0001 = SRC 1
- X0010 = SRC 2
- X0011 = SRC 3
- X0100 = SRC 4
- X0101 = SRC 5
- X0110 = GATE 1
- X0111 = GATE 2
- X1000 = GATE 3
- X1001 = GATE 4
- X1010 = GATE 5
- X1011 = F1
- X1100 = F2
- X1101 = F3
- X1110 = F4
- X1111 = F5

Count Control

- 0XXXX = Disable Special Gate
- 1XXXX = Enable Special Gate
- X0XXX = Reload from Load
- X1XXX = Reload from Load or Hold
- XX0XX = Count Once
- XX1XX = Count Repetitively
- XXX0X = Binary Count
- XXX1X = BCD Count
- XXXX0 = Count Down
- XXXX1 = Count Up

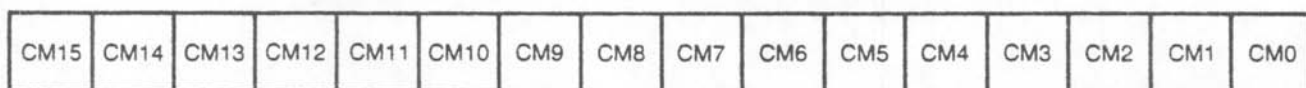

Gating Control

- 000 = No Gating
- 001 = Active High Level TCN-1
- 010 = Active High Level GATE N+1
- 011 = Active High Level GATE N-1
- 100 = Active High Level GATE N
- 101 = Active Low Level GATE N
- 110 = Active High Edge GATE N
- 111 = Active Low Edge GATE N

Output Control

- 000 = Inactive, Output Low
- 001 = Active High Terminal Count Pulse
- 010 = TC Toggled
- 011 = Illegal
- 100 = Inactive, Output High Impedance
- 101 = Active Low Terminal Count Pulse
- 110 = Illegal
- 111 = Illegal

Note: See Figure 17 for restrictions on Count Control and Gating Control bit combinations.

Figure 18. Counter Mode Register Bit Assignments.

MOS-176

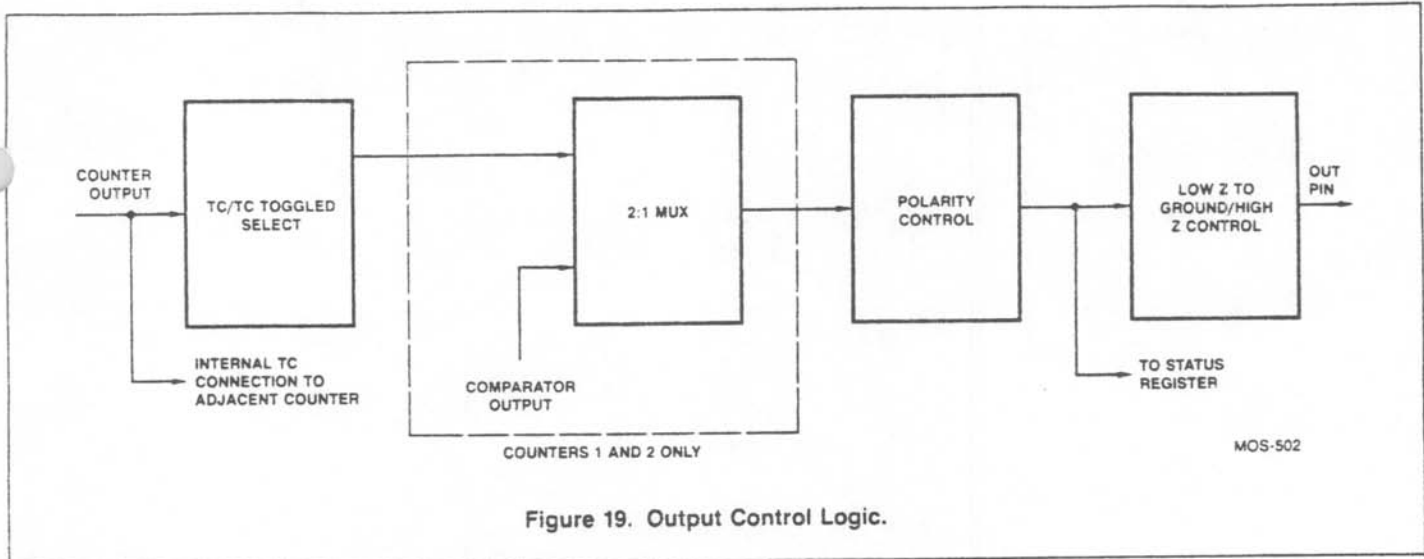

Figure 19. Output Control Logic.

The toggle output is 1/2 the frequency of TC. The TC Toggled output will frequently be used to generate variable duty-cycle square waves in Operating Modes G through K.

In Mode L the TC Toggled output can be used to generate a one-shot function, with the delay to the start of the output pulse and the width of the output pulse separately programmable. With selection of the minimum delay to the start of the pulse, the output will toggle on the source pulse following application of the triggering Gate edge.

Note that the TC Toggled output form contains no implication about whether the output is active-high or active-low. Unlike the TC output, which generates a transient pulse which can clearly be active-high or active-low, the TC Toggled output waveform only flips the state of the output on each TC. The sole criteria of whether the TC Toggled output is active-high or active-low is the level of the output at the start of the count cycle. This can be controlled by the Set and Clear Output commands.

TC (TERMINAL COUNT)

On each Terminal Count (TC), the counter will reload itself from the Load or Hold register. TC is defined as that period of time when the counter contents would have been zero had no reload occurred. Some special conditions apply to counter operation immediately before and during TC.

1. In the clock cycle before TC, an internal signal is generated that commits the counter to go to TC on the next count, and retriggering by a hardware Gate edge (Modes N, O, Q and R) or a software LOAD or LOAD-and-ARM command will not extend the time to TC. Note that the "next count" driving the counter to TC can be caused by the application of a count

source edge (in level gating modes, the edge must occur while the gate is active, or it will be disregarded), by the application of a LOAD or LOAD-and-ARM command (see 2 below) or by the application of a STEP command.

2. If a LOAD or LOAD-and-ARM command is executed during the cycle preceding TC, the counter will immediately go to TC. If these commands are issued during TC, the TC state will immediately terminate.
3. When TC is active, the counter will always count the next source edge issued to it, even if it is disarmed or gated off during TC. This means that TC will never be active for longer than one count period and it may, in fact, be shorter if a STEP command or a LOAD or LOAD-and-ARM command is applied during TC (see item 2 above). This also means that a counter that is disarmed or stopped on TC is actually disarmed/stopped immediately following TC.

This may cause count sequences different from what a user might expect. Since the counter is always reloaded at the start of TC, and since it always counts at the end of TC, the counter contents following TC will differ by one from the reloaded value, irrespective of the operating mode used.

If the reloaded value was 0001 for down counting, 9999 (BCD) for BCD up counting or FFFF (hex) for binary up counting, the count at the end of TC will drive the counter into TC again regardless of whether the counter is gated off or disarmed. As long as these values are reloaded, the TC output will stay active. If a TC Toggled output is selected, it will toggle on each count. Execution of a LOAD, LOAD-and-ARM or STEP command with these counter contents will act the same as application of a source pulse, causing TC to remain active and a TC Toggled output to toggle.

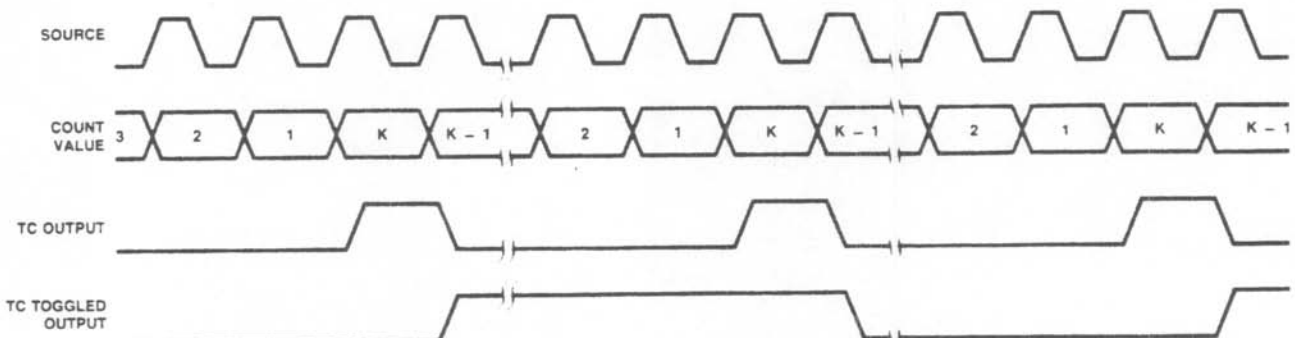

Figure 20. Counter Output Waveforms.

MOS-503

Count Control

Counter Mode bits CM3 through CM7 specify the various options available for direct control of the counting process. CM3 and CM4 operate independently of the others and control up/down and BCD/binary counting. They may be combined freely with other control bits to form many types of counting configurations. The other three bits and the Gating Control field interact in complex ways. Bit CM5 controls the repetition of the count process. When CM5 = 1, counting will proceed in the specified mode until the counter is disarmed. When CM5 = 0, the count process will proceed only until one full cycle of operation occurs. This may occur after one or two TC events. The counter is then disarmed automatically. The single or double TC requirement will depend on the state of other control bits. Note that even if the counter is automatically disarmed upon a TC, it always counts the count source edge which generates the trailing TC edge.

When TC occurs, the counter is always reloaded with a value from either the Load register or the Hold register. Bit CM6 specifies the source options for reloading the counter. When CM6 = 0, the contents of the Load register will be transferred into the counter at every occurrence of TC. When CM6 = 1, the counter reload location will be either the Load or Hold Register. The reload location in this case may be controlled externally by using a GATE pin (Modes S and V) or may alternate on each TC (Modes G through L). With alternating sources and with the TC Toggled output selected, the duty cycle of the output waveform is controlled by the relative Load and Hold values and very fine resolution of duty cycle ratios may be achieved.

Bit CM7 controls the special gating functions that allow retriggering and the selection of Load or Hold sources for counter reloading. The use and definition of CM7 will depend on the status of the Gating Control field and bits CM5 and CM6.

When some form of Gating is specified, CM7 controls hardware retriggering. In this case, when CM7 = 0 hardware retriggering does not occur; when CM7 = 1 the counter is retriggered any time an active-going Gate edge occurs. Retriggering causes the counter value to be saved in the Hold register and the Load register contents to be transferred into the counter.

Whenever hardware retriggering is enabled (Modes N, O, Q and R) all active going Gate edges initiate retrigger operations. On application of the Gate edge, the counter contents will be transferred to the Hold register. On the first qualified source edge after application of the retriggering Gate edge, the Load register contents will be transferred into the counter. (Qualified source edges are edges which occur while the counter is gated on and Armed.)

This means that if level gating is used, the edge occurring on active-going gate transitions will initiate a retrigger. Similarly, when edge gating is enabled, an edge used to start the counter will also initiate a retrigger. The first count source edge applied after the Gate edge will not increment/decrement the counter but reload it.

When No Gating is specified, the definition of CM7 changes. In this case, when CM7 = 0 the Gate input has no effect on the counting; when CM7 = 1 the GATE N input specifies the reload source (either the Load or Hold register) used to reload the counter when TC occurs. Figure 17 shows the various available control combinations for these interrelated bits.

Count Source Selection

Counter Mode bits CM8 through CM12 specify the source used as input to the counter and the active edge that is counted. Bit CM12 controls the polarity for all the sources: logic zero counts rising edges and logic one counts falling edges. Bits CM8 through CM11 select 1 of 16 counting sources to route to the counter input. Five

of the available inputs are internal frequencies derived from the internal oscillator (see Figure 16 for frequency assignments). Ten of the available inputs are interface pins; five are labeled SRC and five are labeled GATE.

The 16th available input is the TC output from the adjacent lower-numbered counter. (The Counter 5 TC wraps around to the Counter 1 input.) This option allows internal concatenating that permits very long counts to be accumulated. Since all five counters may be concatenated, it is possible to configure a counter that is 80 bits long on one Am9513 chip. When TCN-1 is the source, the count ripples between the connected counters. External connections can also be made, and can use the toggle bit for even longer counts. This is easily accomplished by selecting a TC Toggled output mode and wiring OUTN to one of the SRC inputs.

Gating Control

Counter Mode bits CM13 through CM15 specify the hardware gating options. When "no gating" is selected (000) the counter will proceed unconditionally as long as it is armed. For any other gating mode, the count process is conditioned by the specified gating configuration.

For a code of 100 in this field, counting can proceed only when the pin labeled GATEN associated with Counter N is at a logic high level. When it goes low, counting is simply suspended until the Gate goes high again. A code of 101 performs the same function with an opposite active polarity. Codes 010 and 011 offer the same function as 100, but specify alternate input pins as Gating Sources. This allows any of three interface pins to be used as gates for a given counter. On Counter 4, for example, pin 34, pin 35 or pin 36 may be used to perform the gating function. This also allows a single Gate pin to simultaneously control up to three counters.

For codes of 110 or 111 in this field, counting proceeds after the specified active Gate edge until one or two TC events occur. Within this interval the Gate input is ignored, except for the retriggering option. When repetition is selected, a cycle will be repeated as soon as another Gate edge occurs. With repetition selected, any Gate edge applied after TC goes active will start a new count cycle. Edge gating is useful when implementing a digital single-shot since the gate can serve as a convenient firing trigger.

A 001 code in this field selects the TC output from the adjacent lower-numbered counter as the gate. Thus, one counter may be configured to generate a counting "window" for another counter.

COMMAND DESCRIPTIONS

The command set for the Am9513 allows the host processor to customize and manage the operating modes and features for particular applications, to initialize and update both the internal data and control information, and to manipulate operating bits during operation. Commands are entered directly into the 8-bit Command register by writing into the Control port (see Figure 7).

All available commands are described in the following text. Figure 21 summarizes the command codes and includes a brief description of each function. Figure 22 shows all the unused code combinations: unused codes should not be entered into the Command register since undefined activities may occur.

Six of the command types are used for direct software control of the counting process and they each contain a 5-bit S field. In a linear-select fashion, each bit in the S field corresponds to one of the five general counters (S1 = Counter 1, S2 = Counter 2, etc.). When an S bit is a one, the specified operation is performed on the counter so designated; when an S bit is a zero, no operation

Command Code								Command Description
C7	C6	C5	C4	C3	C2	C1	C0	
0	0	0	E2	E1	G4	G2	G1	Load Data Pointer register with contents of E and G fields. (G ≠ 000, G ≠ 110)
0	0	1	S5	S4	S3	S2	S1	Arm counting for all selected counters
0	1	0	S5	S4	S3	S2	S1	Load contents of specified source into all selected counters
0	1	1	S5	S4	S3	S2	S1	Load and Arm all selected counters
1	0	0	S5	S4	S3	S2	S1	Disarm and Save all selected counters
1	0	1	S5	S4	S3	S2	S1	Save all selected counters in hold register
1	1	0	S5	S4	S3	S2	S1	Disarm all selected counters
1	1	1	0	1	N4	N2	N1	Set output bit N (001 ≤ N ≤ 101)
1	1	1	0	0	N4	N2	N1	Clear output bit N (001 ≤ N ≤ 101)
1	1	1	1	0	N4	N2	N1	Step counter N (001 ≤ N ≤ 101)
1	1	1	0	1	0	0	0	Set MM14 (Disable Data Pointer Sequencing)
1	1	1	0	1	1	1	0	Set MM12 (Gate off FOUT)
1	1	1	0	1	1	1	1	Set MM13 (Enter 16-bit bus mode)
1	1	1	0	0	0	0	0	Clear MM14 (Enable Data Pointer Sequencing)
1	1	1	0	0	1	1	0	Clear MM12 (Gate on FOUT)
1	1	1	0	0	1	1	1	Clear MM13 (Enter 8-bit bus mode)
1	1	1	1	1	1	1	1	Master reset

Figure 21. Am9513 Command Summary.

occurs for the corresponding counter. This type of command format has three basic advantages. It saves host software by allowing any combination of counters to be acted on by a single command. It allows simultaneous action on multiple counters where synchronization of commands is important. It allows counter-specific service routines to control individual counters without needing to be aware of the operating context of other counters.

Arm Counters

Coding:

C7	C6	C5	C4	C3	C2	C1	C0
0	0	1	S5	S4	S3	S2	S1

Description: Any combination of counters, as specified by the S field, will be enabled for counting. A counter must be armed before counting can commence. Once armed, the counting process may be further enabled or disabled using the hardware gating facilities. This command can only arm or do nothing for a given counter; a zero in the S field does not disarm the counter.

ARM and DISARM commands can be used to gate counter operation on and off under software control. DISARM commands entered while a counter is in the TC state will not take effect until the counter leaves TC. This ensures that the counter never latches up in a TC state. (The counter may leave the TC state because of application of a count source edge; execution of a LOAD or LOAD-and-ARM command; or execution of a STEP command.)

In modes which alternate reload sources (Modes G-L), the ARMing operation is used as a reset for the logic which determines which reload source to use on the upcoming TC. Following

each ARM or LOAD-and-ARM command, a counter in one of these modes will reload from the Hold register on the first TC and alternate reload sources thereafter (reload from the Load register on the second TC, the Hold register on the third, etc.).

In edge gating modes (Modes C, F, I, L, O and R) after disarming and rearming a triggered counter, a new Gate edge will be required to resume counting. In Modes C, F, I and L counting will resume from the current counter value. In modes O and R the new Gate edge will both start and retrigger the counter, causing the counter to be reloaded with a new value.

Load Counters

Coding:

C7	C6	C5	C4	C3	C2	C1	C0
0	1	0	S5	S4	S3	S2	S1

Description: Any combination of counters, as specified in the S field, will be loaded with previously entered values. The source of information for each counter will be either the associated Load register or the associated Hold register, as determined by the operating configuration in the Mode register. The Load/Hold contents are not changed. This command will cause a transfer independent of any current operating configuration for the counter. It will often be used as a software retrigger, or as counter initialization prior to active hardware gating.

If a LOAD or LOAD-and-ARM command is executed during the cycle preceding TC, the counter will go immediately to TC. This occurs because the LOAD operation is performed by generating a pseudo-count pulse, internal to the Am9513, and the Am9513 is expecting to go into TC on the next count pulse. The reload

source used to reload the counter will be the same as that which would have been used if the TC were generated by a source edge rather than by the LOAD operation.

Execution of a LOAD or LOAD-and-ARM command while a counter is in TC will cause the TC to end. For Armed counters in all modes except S or V, the reload source used will be that to be used for the upcoming TC. (The LOADing operation will not alter the selection of reload source for the upcoming TC.) For Disarmed counters in modes except S or V, the reload sources used will be the LOAD register. For modes S or V, the reload source will be selected by the GATE input, regardless of whether the counter is Armed or Disarmed.

Special considerations apply when modes with alternating reload sources are used (Modes G-L). If a LOAD command drives the counter to TC in these modes, the reload source for the next TC will be from the opposite reload location. In other words, the LOAD-generated TC will cause the reload sources to alternate just as a TC generated by a source edge would. Note that if a second LOAD command is issued during the LOAD-generated TC (or during any other TC, for that matter) the second LOAD command will terminate the TC and cause a reload from the source designated for use with the next TC. The second LOAD will not alter the reload source for the next TC since the second LOAD does not generate a TC; reload sources alternate on TCs only, not on LOAD commands.

Load and Arm Counters

Coding:	C7	C6	C5	C4	C3	C2	C1	C0
	0	1	1	S5	S4	S3	S2	S1

Description: Any combination of counters, as specified in the S field, will be first loaded and then armed. This command is equivalent to issuing a LOAD command and then an ARM command.

A LOAD-and-ARM command which drives a counter to TC generates the same sequence of operations as execution of a LOAD command and then an ARM command. In modes which disarm on TC (Modes A-C and N-O, and Modes G-I and S if the current TC is the second in the cycle) the ARM part of the LOAD-and-ARM command will re-enable counting for another cycle. In modes which alternate reload sources (Modes G-L) the ARming operating will cause the next TC to reload from the HOLD register, irrespective of which reload source the current TC used.

Disarm Counters

Coding:	C7	C6	C5	C4	C3	C2	C1	C0
	1	1	0	S5	S4	S3	S2	S1

Description: Any combination of counters, as specified by the S field, will be disabled from counting. A disarmed counter will cease all counting independent of other control conditions. The only exception to this is that a counter in the TC state will always count once, in order to leave TC, before DISARming. This count may be generated by a source edge, by a LOAD or LOAD-and-ARM command (the LOAD-and-ARM command will negate the DISARM command) or by a STEP command. A disarmed counter may be updated using the LOAD command and may be read using the SAVE command. A count process may be resumed using an ARM command. See the ARM command description for further details.

Save Counters

Coding:	C7	C6	C5	C4	C3	C2	C1	C0
	1	0	1	S5	S4	S3	S2	S1

Description: Any combination of counters, as specified by the S field, will have their contents transferred into their associated Hold register. The transfer takes place without interfering with any counting that may be underway. This command will overwrite any previous Hold register contents. The SAVE command is designed to allow an accumulated count to be preserved so that it can be read by the host CPU at some later time.

Disarm and Save Counters

Coding:	C7	C6	C5	C4	C3	C2	C1	C0
	1	0	0	S5	S4	S3	S2	S1

Description: Any combination of counters, as specified by the S field, will be disarmed and the contents of the counter will be transferred into the associated Hold registers. This command is identical to issuing a DISARM command followed by a SAVE command.

Set Output

Coding:	C7	C6	C5	C4	C3	C2	C1	C0
	1	1	1	0	1	N4	N2	N1

(001 ≤ N ≤ 101)

Description: The output toggle for counter N is set. The OUTN signal will be driven high unless a TC output is specified.

Clear Output

Coding:	C7	C6	C5	C4	C3	C2	C1	C0
	1	1	1	0	0	N4	N2	N1

(001 ≤ N ≤ 101)

Description: The output toggle for counter N is reset. The OUTN signal will be driven low unless a TC output is specified.

Step Counter

Coding:	C7	C6	C5	C4	C3	C2	C1	C0
	1	1	1	1	0	N4	N2	N1

(001 ≤ N ≤ 101)

Description: Counter N is incremented or decremented by one, depending on its operating configuration. If the Counter Mode register associated with the selected counter has its CM3 bit cleared to zero, this command will cause the counter to decrement by one. If CM3 is set to a logic high, this command will increment the counter by one. The STEP command will take effect even on a disarmed counter.

Load Data Pointer Register

Coding:	C7	C6	C5	C4	C3	C2	C1	C0
	0	0	0	E2	E1	G4	G2	G1

(G4, G2, G1 ≠ 000, ≠ 110)

Description: Bits in the E and G fields will be transferred into the corresponding Element and Group fields of the Data Pointer

register as shown in Figure 8. The Byte Pointer bit in the Data Pointer register is set. Transfers into the Data Pointer only occur for G field values of 001, 010, 011, 100, 101 and 111. Values of 000 and 110 for G should not be used. See the "Setting the Data Pointer Register" section of this document for additional details.

Disable Data Pointer Sequencing

Coding:

C7	C6	C5	C4	C3	C2	C1	C0
1	1	1	0	1	0	0	0

Description: This command sets Master Mode bit 14 without affecting other bits in the Master Mode register. MM14 controls the automatic sequencing of the Data Pointer register. Disabling the sequencing allows repetitive host processor access to a given internal location without repetitive updating of the Data Pointer. MM14 may also be controlled by loading a full word into the Master Mode register.

Enable Data Pointer Sequencing

Coding:

C7	C6	C5	C4	C3	C2	C1	C0
1	1	1	0	0	0	0	0

Description: This command clears Master Mode bit 14 without affecting other bits in the Master Mode register. MM14 controls the automatic sequencing of the Data Pointer register. Enabling the sequencing allows sequential host processor access to several internal locations without repetitive updating of the Data Pointer. MM14 may also be controlled by loading a full word into the Master Mode register. See the "Data Pointer Register" section of this document for additional information on Data Pointer sequencing.

Enable 16-Bit Data Bus

Coding:

C7	C6	C5	C4	C3	C2	C1	C0
1	1	1	0	1	1	1	1

Description: This command sets Master Mode bit 13 without affecting other bits in the Master Mode register. MM13 controls the multiplexer in the data bus buffer. When MM13 is set, no multiplexing takes place and all 16 external data bus lines are used to transfer information into and out of the STC. MM13 may also be controlled by loading the full Master Mode register in parallel.

Enable 8-Bit Data Bus

Coding:

C7	C6	C5	C4	C3	C2	C1	C0
1	1	1	0	0	1	1	1

Description: This command clears Master Mode bit 13 without affecting other bits in the Master Mode register. MM13 controls the multiplexer in the data bus buffer. When MM13 is cleared, the multiplexer is enabled and 16-bit internal information is transferred eight bits at a time to the eight low-order external data bus lines. MM13 may also be controlled by loading the full Master Mode register in parallel.

Gate Off FOUT

Coding:

C7	C6	C5	C4	C3	C2	C1	C0
1	1	1	0	1	1	1	0

Description: This command sets Master Mode bit 12 without affecting other bits in the Master Mode register. MM12 controls the output state of the FOUT signal. When gated off, the FOUT line will exhibit a low impedance to ground. MM12 may also be controlled by loading the full Master Mode register in parallel.

Gate On FOUT

Coding:

C7	C6	C5	C4	C3	C2	C1	C0
1	1	1	0	0	1	1	0

Description: This command clears Master Mode bit 12 without affecting other bits in the Master Mode register. MM12 controls the output status of the FOUT signal. When MM12 is cleared, FOUT will become active and will drive out the selected and divided FOUT signal. MM12 may also be controlled by loading the full Master Mode register in parallel. When FOUT is gated on or off, a transient pulse may be generated on the FOUT signal.

Master Reset

Coding:

C7	C6	C5	C4	C3	C2	C1	C0
1	1	1	1	1	1	1	1

Description: The Master Reset command duplicates the action of the power-on reset circuitry. It disarms all counters, enters 0000 in the Master Mode, Load and Hold registers and enters 0B00 (hex) in the Counter Mode registers.

Following either a power-up or software reset, the LOAD command should be applied to all the counters to clear any that may be in a TC state. The Data Pointer register should also be set to a legal value, since reset does not initialize it. A complete reset operation is given in the following.

1. Using the procedure given in the "Command Initiation" section of this data sheet, enter the FF (hex) command to perform a software reset.
2. Using the "Command Initiation" procedure, enter the LOAD command for all counters, opcode 5F (hex).
3. Using the procedure given in the "Setting the Data Pointer Register" section of this data sheet, set the Data Pointer to a valid code. The legal Data Pointer codes are given in Figure 9.

The Master Mode, Counter Mode, Load and Hold registers can now be initialized to the desired values.

	C7	C6	C5	C4	C3	C2	C1	C0
	1	1	1	1	0	0	0	0
	1	1	1	1	0	1	1	0
	1	1	1	1	0	1	1	1
	0	0	0	X	X	1	1	0
	0	0	0	X	X	0	0	0
*	1	1	1	1	1	X	X	X

*Unused except when XXX = 111.

Figure 22. Am9513 Unused Command Codes.

MAXIMUM RATINGS beyond which useful life may be impaired

Storage Temperature	-65°C to +150°C
Ambient Temperature Under Bias	-55°C to +125°C
VCC with Respect to VSS	-0.5V to +7.0V
All Signal Voltages with Respect to VSS	-0.5V to +7.0V
Power Dissipation (Package Limitation)	1.5W

The products described by this specification include internal circuitry designed to protect input devices from damaging accumulations of static charge. It is suggested, nevertheless, that conventional precautions be observed during storage, handling and use in order to avoid exposure to excessive voltages.

OPERATING RANGE

Part Number	Temperature	VCC	VSS
Am9513DC	0°C ≤ T _A ≤ +70°C	+5V ±5%	0V
Am9513DM	-55°C ≤ T _A ≤ +125°C	+5V ±5%	0V

ELECTRICAL CHARACTERISTICS over operating range (Notes 1 and 2)

Parameter	Description	Test Conditions	Min	Typ	Max	Units
VIL	Input Low Voltage	All Inputs Except X2	VSS-0.5		0.8	Volts
		X2 Input	VSS-0.5		0.8	
VIH	Input High Voltage	All Inputs Except X2	2.0		VCC	Volts
		X2 Input	3.4		VCC	
VITH	Input Hysteresis (SRC and GATE Inputs Only)		0.2	0.3		Volts
VOL	Output Low Voltage	IOL = 3.2mA			0.4	Volts
VOH	Output High Voltage	IOH = -200µA	2.4			Volts
		IOH = -1.5mA	1.5			
IIX	Input Load Current (Except X2)	VSS ≤ VIN ≤ VCC			±10	µA
IOZ	Output Leakage Current (Except X1)	VSS ≤ VOUT ≤ VCC High Impedance State			±25	µA
ICC	VCC Supply Current	T _A = -55°C			275	mA
		T _A = 0°C			225	
		T _A = +25°C		160		
CIN	Input Capacitance	f = 1MHz, T _A = +25°C, All pins not under test at 0V.			10	pF
COUT	Output Capacitance				15	
CIO	IN/OUT Capacitance				20	

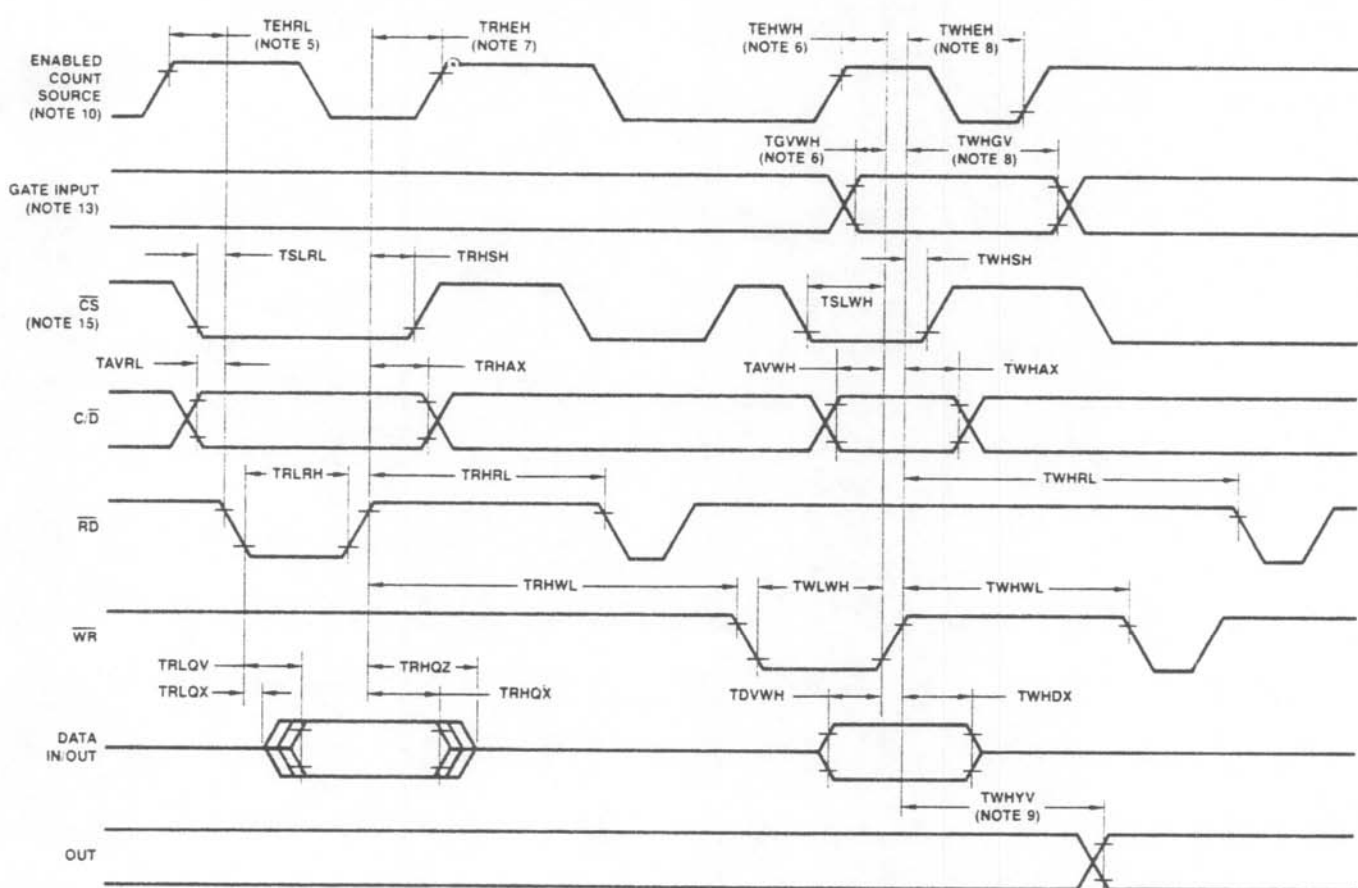

Figure 23. Bus Transfer Switching Waveforms.

MOS-183

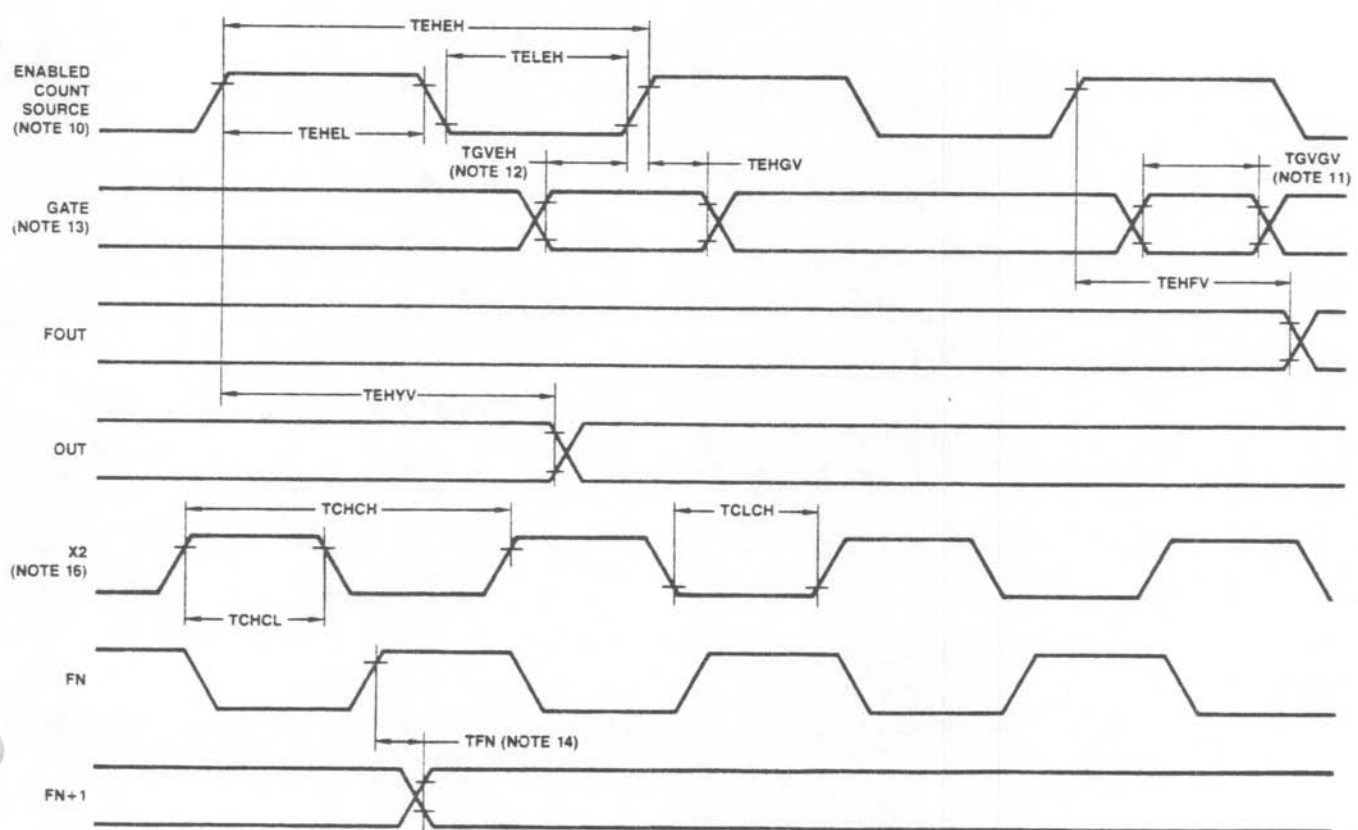

Figure 24. Counter Switching Waveforms.

MOS-184

SWITCHING CHARACTERISTICS over operating range (Notes 2, 3, 4)

Am9513

Parameter	Description	Figure	Min	Max	Min	Max	Units
TAVRL	C/D Valid to Read Low	23	25				ns
TAVWH	C/D Valid to Write High	23	170				ns
TCHCH	X2 High to X2 High (X2 Period)	24	145				ns
TCHCL	X2 High to X2 Low (X2 High Pulse Width)	24	70				ns
TCLCH	X2 Low to X2 High (X2 Low Pulse Width)	24	70				ns
TDVWH	Data In Valid to Write High	23	80				ns
TEHEH	Count Source High to Count Source High (Source Cycle Time) (Note 10)	24	145				ns
TEHEL TELEH	Count Source Pulse Duration (Note 10)	24	70				ns
TEHFV	Count Source High to FOUT Valid (Note 10)	24		500			ns
TEHGV	Count Source High to Gate Valid (Level Gating Hold Time) (Notes 10, 12, 13)	24	40				ns
TEHRL	Count Source High to Read Low (Set-up Time) (Notes 5, 10)	23	190				ns
TEHWH	Count Source High to Write High (Set-up Time) (Notes 6, 10)	23	100				ns
TEHYV	Count Source High to Out Valid (Note 10)	TC Output	24		300		ns
		Immediate or Delayed Toggle Output	24		300		
		Comparator Output	24		350		
TFN	FN High to FN+1 Valid (Note 14)	24		75			ns
TGVEH	Gate Valid to Count Source High (Level Gating Set-up Time) (Notes 10, 12, 13)	24	70				ns
TGVGV	Gate Valid to Gate Valid (Gate Pulse Duration) (Notes 11, 13)	24	145				ns
TGVWH	Gate Valid to Write High (Notes 6, 13)	23	0				ns
TRHAX	Read High to C/D Don't Care	23	0				ns
TRHEH	Read High to Count Source High (Notes 7, 10)	23	0				ns
TRHQX	Read High to Data Out Invalid	23	20				ns
TRHQZ	Read High to Data Out at High Impedance (Data Bus Release Time)	23		85			ns
TRHRL	Read High to Read Low (Read Recovery Time)	23		1000			ns
TRHSH	Read High to CS High (Note 15)	23	0				ns
TRHWL	Read High to Write Low (Read Recovery Time)	23		1000			ns
TRLQV	Read Low to Data Out Valid	23		160			ns
TRLQX	Read Low to Data Bus Driven (Data Bus Drive Time)	23	20				ns
TRLRH	Read Low to Read High (Read Pulse Duration) (Note 15)	23	160				ns
TSLRL	CS Low to Read Low (Note 15)	23	20				ns
TSLWH	CS Low to Write High (Note 15)	23	170				ns
TWHAX	Write High to C/D Don't Care	23	0				ns
TWHDX	Write High to Data In Don't Care	23	0				ns
TWHEH	Write High to Count Source High (Notes 8, 10, 17)	23	400				ns
TWHGV	Write High to Gate Valid (Notes 8, 13, 17)	23	400				ns
TWHRL	Write High to Read Low (Write Recovery Time)	23		1000			ns
TWHSH	Write High to CS High (Note 15)	23	0				ns
THWL	Write High to Write Low (Write Recovery Time)	23		1000			ns
TWHYV	Write High to Out Valid (Note 9, 17)	23		650			ns
TWLWH	Write Low to Write High (Write Pulse Duration) (Note 15)	23	150				ns

NOTES:

1. Typical values are for $T_A = 25^\circ\text{C}$, nominal supply voltage and nominal processing parameters.
2. Test conditions assume transition times of 10ns or less, timing reference levels of 0.8V and 2.0V and output loading of one TTL gate plus 100pF, unless otherwise noted.
3. Abbreviations used for the switching parameter symbols are given as the letter T followed by four or five characters. The first and third characters represent the signal names on which the measurements start and end. Signal abbreviations used are:

A (Address) = C/D
C (Clock) = X2
D (Data In) = DB0-DB15
E (Enabled counter source input) = SRC1-SRC5, GATE1-GATE5, F1-F5, TCN-1
F = FOUT
G (Counter gate input) = GATE1-GATE5, TCN-1
Q (Data Out) = DB0-DB15
R (Read) = RD
S (Chip Select) = CS
W (Write) = WR
Y (Output) = OUT1-OUT5

The second and fourth letters designate the reference states of the signals named in the first and third letters respectively, using the following abbreviations.

H = High
L = Low
V = Valid
X = unknown or don't care
Z = high impedance

4. Switching parameters are listed in alphabetical order.
5. Any input transition that occurs before this minimum setup requirement will be reflected in the contents read from the status register.
6. Any input transition that occurs before this minimum setup requirement will act on the counter before the execution of the operation initiated by the write. Failure to meet this setup time when issuing commands to the counter may result in incorrect counter operation.
7. Any input transition that occurs after this minimum hold time is guaranteed to not influence the contents read from the status register on the current read operation.
8. Any input transition that occurs after this minimum hold time is guaranteed to be seen by the counter as occurring after the action initiated by the write operation. Failure to meet this hold time when issuing commands to the counter may result in incorrect counter operation.
9. This parameter applies to cases where the write operation causes a change in the output bit.
10. The enabled count source is one of F1-F5, TCN-1, SRC1-SRC5 or GATE1-GATE5, as selected in the applicable Counter Mode register. The timing diagram assumes the counter counts on rising source edges. The timing specifications are the same for falling-edge counting.
11. This parameter applies to edge gating (CM15-CM13 = 110 or 111) and gating when both CM7 = 1 and CM15-CM13 \neq 000. This parameter represents the minimum GATE pulse width needed to ensure that the pulse initiates counting or counter reloading.
12. This parameter applies to both edge and level gating (CM15-CM13 = 001 through 111) and gating when both CM7 = 1 and CM15-CM13 = 000. This parameter represents the minimum setup or hold times to ensure that the Gate input is seen at the intended level on the active source edge. Failure to meet the required setup and hold times may result in incorrect counter operation.
13. This parameter assumes that the GATENA input is unused (16-bit bus mode) or is tied high. In cases where the GATENA input is used, this timing specification must be met by both the GATE and GATENA inputs.
14. Signals F1-F5 cannot be directly monitored by the user. The phase difference between these signals will manifest itself by causing counters using two different F signals to count at different times on nominally simultaneous transitions in the F signals.
15. This timing specification assumes that $\overline{\text{CS}}$ is active whenever $\overline{\text{RD}}$ or $\overline{\text{WR}}$ are active. $\overline{\text{CS}}$ may be held active indefinitely.
16. This parameter assumes X2 is driven from an external gate with a square wave.
17. This parameter assumes that the write operation is to the command register.

APPLICATION INFORMATION

The X1 and X2 inputs can be driven with a RC network, an external TTL-level square wave, or a crystal. Figure 25 shows the suggested methods of connecting different frequency sources to the internal oscillator input.

The use of a crystal provides a highly accurate frequency source at moderate cost, and accordingly, will usually be the preferred method of operation. The Am9513 is designed to use a crystal in a parallel-resonant mode. The two ceramic capacitors connecting X1 and X2 to ground ensure proper loading on the crystal. The capacitor to X2 may be an adjustable type for fine-tuning the resonant frequency for critical applications.

An RC network provides a very low cost frequency source but may exhibit large frequency variations over recommended power supply and temperature ranges. Note that there is a resistor internal to the Am9513 in parallel with any external resistance.

Initialization Procedures

The reset function in the Am9513 is accomplished in two ways: automatically during power-up and by software Master Reset command. Power-up reset circuitry is internally triggered by the rising VCC voltage when a predetermined threshold is reached. An internal flip-flop is set by the rising supply voltage and controls the reset operation. The reset flip-flop remains set until cleared by the first active Chip Select input. A reset may also be initiated by the host processor by entering the Master Reset command. This software reset is active for the duration of the command write; otherwise it performs the same function as the power-up reset.

Following either type of Reset, all five counters are disabled, 0B00 is loaded into each Counter Mode register, and 0000 is loaded in the Master Mode register. This results in each counter being configured to count down in binary on the positive-going edge of the internal F1 frequency source with no repetition or gating. The Master Mode register is cleared to configure the Am9513 for an 8-bit data bus width; binary division of the internal oscillator; FOUT gated on and set to divide F1 by 16; time-of-day mode and comparators 1 and 2 disabled; and the Data Pointer increment enabled.

Reset will clear the Load and Hold registers for each counter but will not change either the counter contents or the Data Pointer register. Following a reset, the "Load All Counters" command (opcode 5F hex) should be issued to clear any counters that may be at TC. The Master Mode and Counter Mode, Load and Hold registers may now be set.

The following initialization procedure should be followed on Counters 1 and 2 when Time-of-Day mode is selected.

1. Set Time-of-Day enabled in the Master Mode register and load Counter Mode registers 1 and 2.
2. If Time-of-Day is to count up, load 0000 in Load registers 1 and 2 and execute command FF43 (Load) to load this value into the counters. This step conditions the count circuitry.
3. Load the desired start time into the Load registers and execute command FF43 again.
4. For counting up, load Load registers 1 and 2 with 0000.
5. Counters 1 and 2 may now be armed.

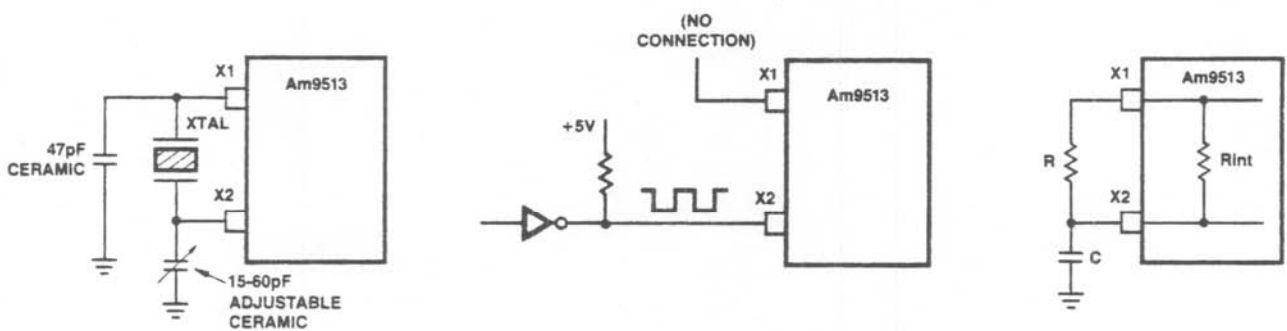

MOS-185

Figure 25. Driving the X1 and X2 Inputs.

PHYSICAL DIMENSIONS

40-Pin Cerdip

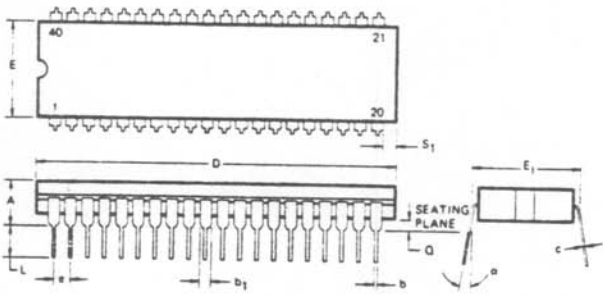

Reference Symbol	Inches	
	Min.	Max.
A	.150	.225
b	.016	.020
b ₁	.045	.065
c	.009	.011
D	2.020	2.100
E	.510	.550
E ₁	.600	.630
e	.090	.110
L	.120	.150
Q	.015	.060
S ₁ *	.005	
α	3°	13°

*From edge of end lead.

40-Pin Molded DIP

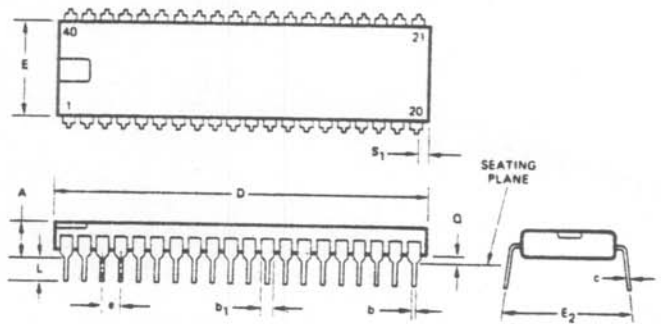

Reference Symbol	Inches	
	Min.	Max.
A	.150	.200
b	.015	.020
b ₁	.055	.065
c	.009	.011
D	2.050	2.080
E	.530	.550
E ₂	.585	.700
e	.090	.110
L	.015	.060
Q	.015	.060
S ₁	.040	.070

40-Pin Side-Brazed Ceramic

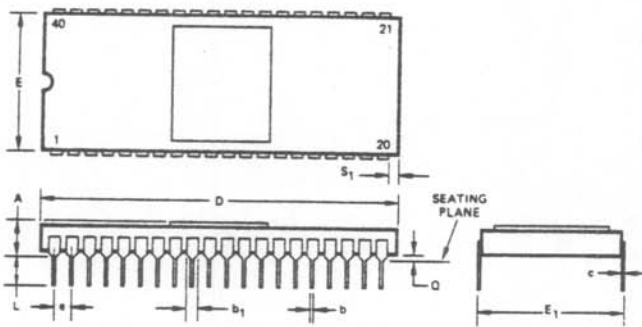

Reference Symbol	Inches	
	Min.	Max.
A	.100	.200
b	.015	.022
b ₁	.030	.060
c	.008	.013
D	1.960	2.040
E	.550	.610
E ₁	.590	.620
e	.090	.110
L	.120	.160
Q	.020	.060
S ₁	.005	

Metallization and Pad Layout

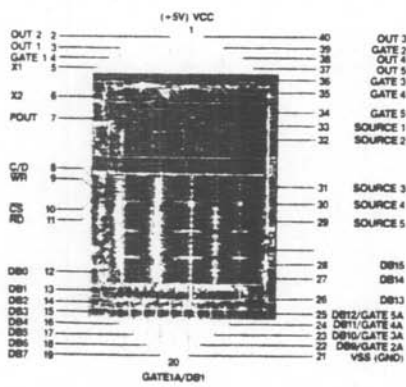

DIE SIZE 0.185" x 0.226"

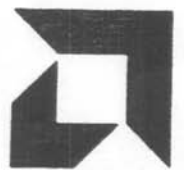

**ADVANCED
MICRO
DEVICES, INC.**
901 Thompson Place
P.O. Box 453
Sunnyvale,
California 94086
(408) 732-2400
TWX: 910-339-9280
TELEX: 34-6306
TOLL FREE
(800) 538-8450