

AMC Doc. #: AMC317\_A  
November 2001



## AMC317

### 1.5A / 3-TERMINAL ADJUSTABLE REGULATOR

DESCRIPTION	FEATURES
<p>The AMC317 series is a 3-terminal adjustable regulator featuring output current of typical 1.5A over a wide output range from 1.2V to 37V. Only two external resistors are required to set the output voltage. This feature provides better line and load regulation than fixed regulators.</p> <p>Also, the AMC317 series offers full overload protection, current limit, and thermal protection features. In most applications, no capacitor is required for the AMC317. However, if the device is located far from the input filter capacitor, then an input bypass will be required. Also, in order to improve the transient response, an output capacitor is recommended.</p>	<ul style="list-style-type: none"> <li>■ <b>Output current capability of 1.5A</b></li> <li>■ <b>Wide output voltage range – adjustable from 1.2V to 37V</b></li> <li>■ <b>Ripple rejection typically 80 dB</b> <ul style="list-style-type: none"> <li>□ Typically 0.1% load regulation</li> <li>□ Built-in over current, over temperature and overload protection.</li> <li>□ Internal thermal overload protection</li> <li>□ Available in 3-Lead TO-220, and surface mount 3-Lead TO-263.</li> <li>□ Identical pin assignment to earlier LM317 series.</li> </ul> </li> </ul>

APPLICATIONS	PACKAGE PIN OUT
--------------	-----------------

- Voltage Regulators
- Power Supplies
- Current Regulators
- Switching Regulators
- Current Limiter
- Constant Current Battery Charger
- Current Limited Charger

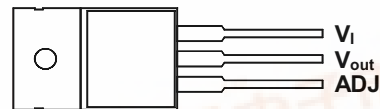

3-Pin Plastic TO-220  
(Top View)

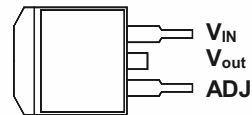

3-Pin Plastic TO-263  
Surface Mount  
(Top View)

ORDER INFORMATION			
T <sub>A</sub> (°C)	T	Plastic TO-220	ST Plastic TO-263
		3-pin	3-pin
<b>0 to 70</b>	<b>AMC317T</b>	<b>AMC317ST</b>	
Note: All surface-mount packages are available in Tape & Reel. Append the letter "T" to part number (i.e. AMC317STT).			

**TYPICAL APPLICATION**

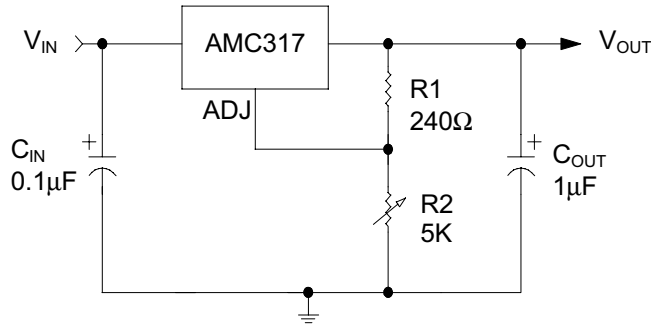

**Note 1:**  $C_{IN}$  is required if the regulator is far from the filter capacitor.  
**Note 2:**  $C_{OUT}$  is recommended to improve the transient response.

**Note 3:**  $V_{OUT} = 1.25V \left( 1 + \frac{R2}{R1} \right) + I_{ADJ}(R2)$

ABSOLUTE MAXIMUM RATINGS (Note 1)	
Input-Output Differential Voltage $V_D$ .....	40V
Operating Junction temperature	
Plastic (T, ST Package) .....	150 °C
Storage Temperature Range .....	-65 °C to 150 °C
Lead temperature (Soldering, 10 seconds) .....	300 °C
Note 1: Exceeding these ratings could cause damage to the device. All voltages are with respect to Ground. Currents are positive into, negative out of the specified terminal.	

THERMAL DATA	
<b>T, ST PACKAGE:</b>	
Thermal Resistance-Junction to Tab, $\theta_{JT}$	3.0 °C/W
Thermal Resistance-Junction to Ambient, $\theta_{JA}$	45 °C/W
Junction Temperature Calculation: $T_J = T_A + (P_D \times \theta_{JA})$ . The $\theta_{JA}$ numbers are guidelines for the thermal performance of the device/pc-board system. All of the above assume no ambient airflow.	

**Maximum Power Calculation:**

$$P_{D(MAX)} = \frac{T_{J(MAX)} - T_{A(MAX)}}{\theta_{JA}}$$

$T_J$ (°C): Maximum recommended junction temperature

$T_A$ (°C): Ambient temperature of the application

$\theta_{JA}$ (°C/W): Junction-to-junction temperature thermal resistance of the package, and other heat dissipating materials.

**The maximum power dissipation for a single-output regulator is :**

$$P_{D(MAX)} = [(V_{IN(MAX)} - V_{OUT(NOM)}) \times I_{OUT(NOM)} + V_{IN(MAX)} \times I_Q]$$

Where:  $V_{OUT(NOM)}$  = the nominal output voltage

$I_{OUT(NOM)}$  = the nominal output current, and

$I_Q$  = the quiescent current the regulator consumes at  $I_{OUT(MAX)}$

$V_{IN(MAX)}$  = the maximum input voltage

Then  $\theta_{JA} = (150^\circ\text{C} - T_A)/P_D$

RECOMMENDED OPERATING CONDITIONS					
Parameter	Symbol	Recommended Operating Conditions			Units
		Min.	Typ.	Max.	
Input-Output differential Voltage	$V_D$	3		40	V
Load Current (with adequate heatsinking)	$I_o$	10		1500	mA
Input Capacitor ( $V_{IN}$ to GND)			0.1		$\mu\text{F}$
Output Capacitor with ESR of $10\Omega$ max., ( $V_{OUT}$ to GND)			1.0		$\mu\text{F}$

ELECTRICAL CHARACTERISTICS						
Unless otherwise specified, these specifications in <b>bold type</b> apply over the operating ambient temperature of $0^\circ\text{C}$ to $+70^\circ\text{C}$ , $V_{IN} - V_{OUT} = 5\text{V}$ , $I_{OUT} = 10\text{mA}$ , $C_{IN} = 0.1\mu\text{F}$ , $C_{OUT} = 1.0\mu\text{F}$ , and are for DC characteristics only. (Low duty cycle pulse testing techniques are used which maintains junction and case temperatures equal to the ambient temperature.)						
Parameter	Symbol	Test Conditions	AMC317			Units
			Min.	Typ.	Max.	
Reference Voltage	$V_{REF}$	$3\text{V} \leq V_{IN} - V_{OUT} \leq 40\text{V}$ , $10\text{mA} \leq I_{OUT} \leq 1.5\text{A}$ , $P \leq 15\text{W}$	<b>1.20</b>	<b>1.25</b>	<b>1.30</b>	V
Line Regulation (see note 2)	$\Delta V_{OI}$	$3\text{V} \leq V_{IN} - V_{OUT} \leq 40\text{V}$ , $T_J = 25^\circ\text{C}$		0.01	0.04	% / V
		$3\text{V} \leq V_{IN} - V_{OUT} \leq 40\text{V}$		<b>0.02</b>	<b>0.07</b>	
Load regulation	$\Delta V_{OL}$	$10\text{mA} \leq I_{OUT} \leq 1.5\text{A}$ , $T_J = 25^\circ\text{C}$		0.1	0.5	%
		$10\text{mA} \leq I_{OUT} \leq 1.5\text{A}$		<b>0.3</b>	<b>1.5</b>	
Minimum Load Current	$I_{OUT(MIN)}$	$V_{IN} - V_{OUT} \leq 40\text{V}$		<b>3.5</b>	<b>10</b>	mA
Adjustment Pin Current	$I_{ADJ}$			<b>50</b>	<b>100</b>	$\mu\text{A}$
Adjustment Pin Current Change	$\Delta I_{ADJ}$	$3\text{V} \leq V_{IN} - V_{OUT} \leq 40\text{V}$ $10\text{mA} \leq I_{OUT} \leq 1.5\text{A}$		<b>0.2</b>	<b>5.0</b>	$\mu\text{A}$
Current Limit	$I_{CL}$	$(V_{IN} - V_{OUT}) \leq 15\text{V}$	<b>1.5</b>	<b>2.2</b>	<b>3.4</b>	A
		$(V_{IN} - V_{OUT}) \leq 24\text{V}$	<b>0.8</b>	<b>1.1</b>		
		$(V_{IN} - V_{OUT}) = 40\text{V}$	<b>0.15</b>	<b>0.4</b>		
Ripple Rejection Ratio (Note 3)	$R_R$	$V_{OUT} = 10\text{V}$ , $f = 120\text{Hz}$		<b>65</b>		dB
		$V_{OUT} = 10\text{V}$ , $f = 120\text{Hz}$ , $10\mu\text{F}$ capacitor between ADJ and GND	<b>66</b>	<b>80</b>		
Output Noise Voltage (Note 3)	$V_{O\text{RMS}}$	$10\text{Hz} \leq f \leq 10\text{KHz}$ , $T_J = 25^\circ\text{C}$		0.003		%
Long Term Stability (Note 3)		$T_J = 125^\circ\text{C}$ , and $V_{IN} - V_{OUT} = 40\text{V}$		0.3	1	%/1000hr
Temperature Stability (Note 3)	$\Delta V_{O(Temp)}$	$T_{MIN} \leq T_J \leq T_{MAX}$		<b>1</b>		%

Note 2: Line regulation is defined as the percentage change in output voltage every 1V change at the input

Note 3: These parameters, although guaranteed, are not tested in production prior to shipment

### TYPICAL APPLICATIONS

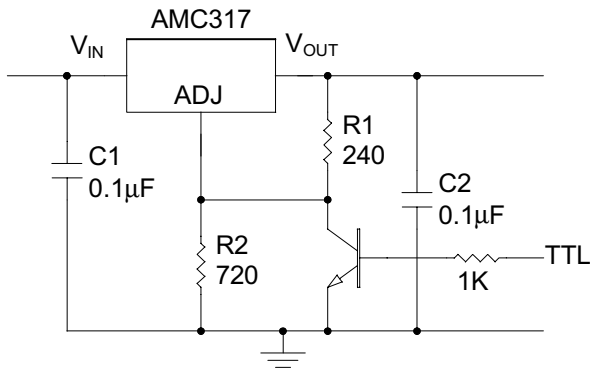

**5V Logic Regulator with Shutdown**  
(Minimum output  $\approx 1.2V$ )

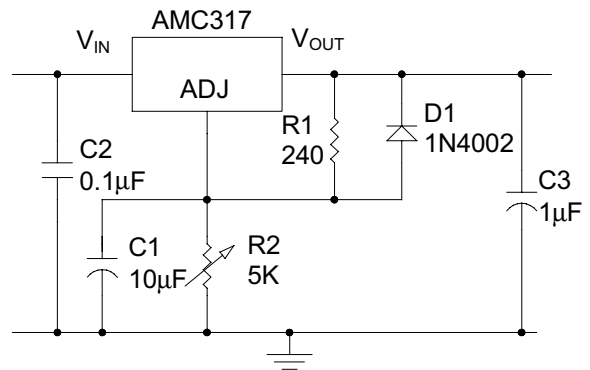

**Adjustable Regulator with Improved Ripple Rejection**

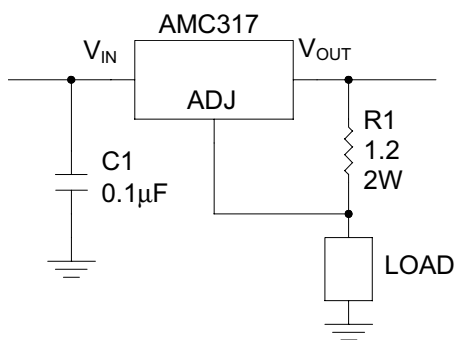

**1A Current Regulator**

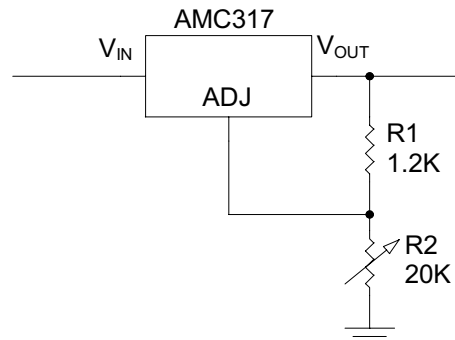

**1.2V - 20V Regulator with Minimum Current ( $\approx 4\text{ mA}$ )**

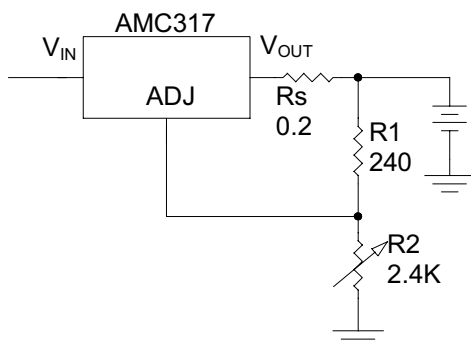

**12V Battery Charger**

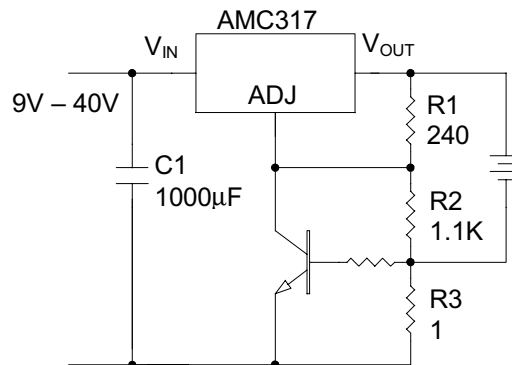

**Current Limited 6V Charger**  
(Peak Current = 0.6A with 1Ω resistor)

**3-Pin Plastic TO-220**

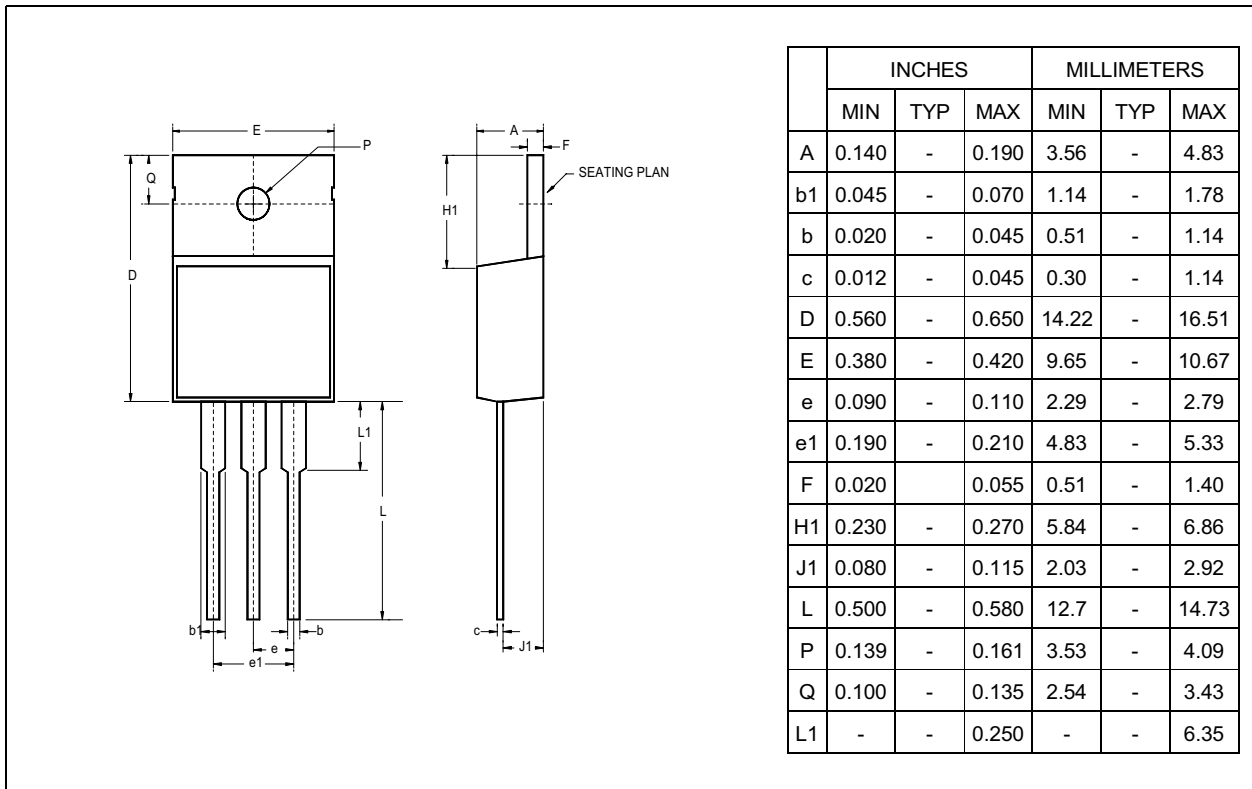

**3-Pin Surface Mount TO-263**

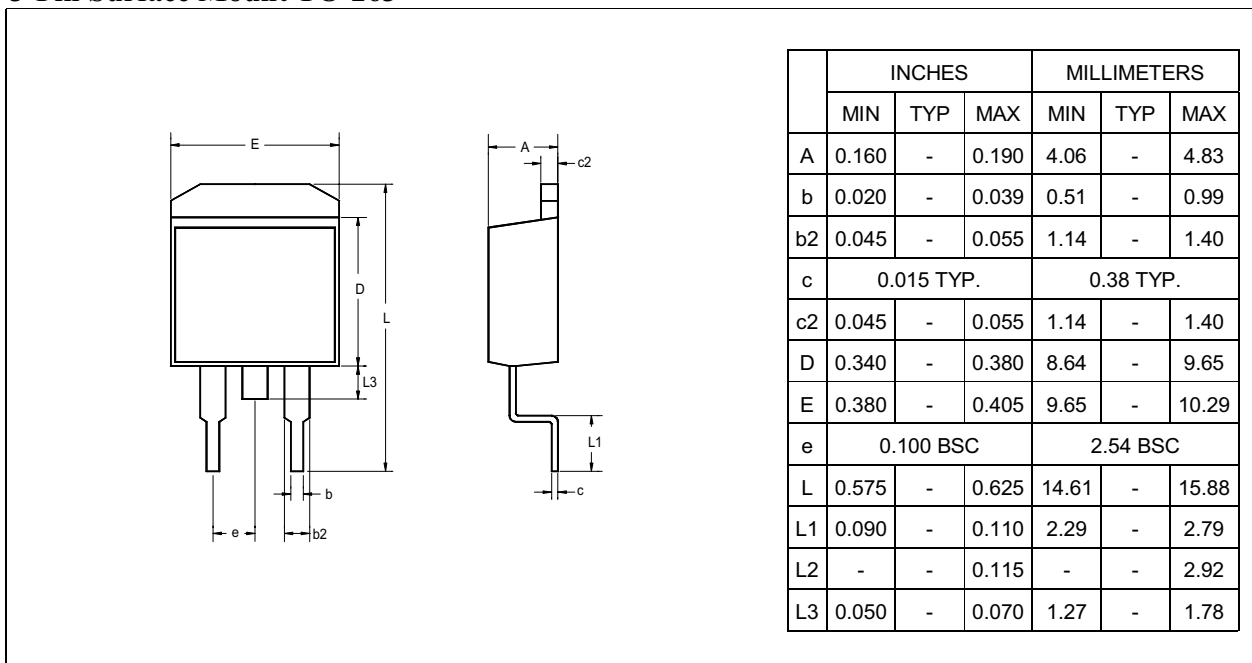

**IMPORTANT NOTICE**

ADD Microtech (ADDM) reserves the right to make changes to its products or to discontinue any integrated circuit product or service without notice, and advises its customers to obtain the latest version of relevant information to verify, before placing orders, that the information being relied on is current.

A few applications using integrated circuit products may involve potential risks of death, personal injury, or severe property or environmental damage. ADDM integrated circuit products are not designed, intended, authorized, or warranted to be suitable for use in life-support applications, devices or systems or other critical applications. Use of ADDM products in such applications is understood to be fully at the risk of the customer. In order to minimize risks associated with the customer's applications, the customer should provide adequate design and operating safeguards.

ADDM assumes no liability to customer product design or application support. ADDM warrants the performance of its products to the specifications applicable at the time of sale.

**U.S.**

**ADD Microtech Inc.  
492 Altamont Drive  
Milpitas, CA 95035**

TEL: (408) 9410420  
FAX: (408) 9410864

**Asia Pacific region**

**ADD Microtech Corp**  
3F, 132, Sec. 4, Chung Hsiao E. Rd.,  
Taipei, Taiwan

TEL: 2-27760166  
FAX: 2-27764208