

AMC Doc. #: AMC5902\_B  
March 2004



**ADD MICROTECH CORP.**

## AMC5902

**6CH Motor Driver for  
CD-ROM, DVD-ROM**

DESCRIPTION	FEATURES
<p>The AMC5902 is a monolithic chip with 6 channel motor drivers designed by advanced BiCMOS process technology. The AMC5902 contains 3 BTL drivers, 2 PWM drivers and a 3-phase spindle motor driver.</p> <p>The AMC5902 is the best fit for modern optical disk driver system which has spindle motor and all actuators.</p> <p>The AMC5902 contains a direct PWM control system for spindle and two slide channels drive thus that the total power consumption can be reduced. Besides, voltage supplies for spindle, slide, focus/tracking and loading can be set separately.</p> <p>Further more, the two control modes -ON/OFF of loading, FOUT amplifier, brake mode select of spindle driver, standby mode, thermal shut down circuit are internally designed in. These features make the AMC5902 an ideal device for optical disc related systems.</p>	<ul style="list-style-type: none"> <li>■ Designed by advanced BiCMOS process, low power and low chip temperature.</li> <li>■ Patented package to reduce chip temperature.</li> <li>■ 3 BTL drivers, 2 PWM drivers and 3 phase spindle motor driver.</li> <li>■ Built-in triangular-wave generator.</li> <li>■ 0 to 5V wide voltage range for input pins</li> <li>■ Thermal shutdown with 30°C hysteresis.</li> <li>□ Built-in current limit, hall bias, short brake, FOUT output and reverse protection circuit.</li> </ul>

APPLICATIONS	PACKAGE PIN OUT
--------------	-----------------

- CD-RW, DVD-RW
- CD-ROM, DVD, DVD-ROM
- Optical Disc Related Systems.

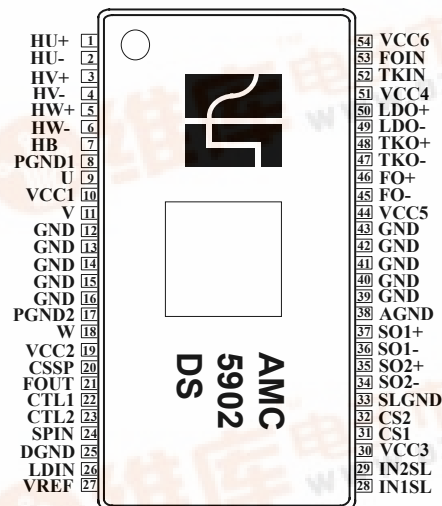

TSOP-54L  
(TOP VIEW)

ORDER INFORMATION		
T <sub>A</sub> (°C)	DS	Plastic TSOP
		54-Pin
0 to 70	AMC5902DS	
	AMC5902DSF	
<p>Note: Package is available with Tape &amp; Reel. Append the letter "T" to part number (i.e. AMC5902DST). The letter "F" is marked for Lead Free process.</p>		

# AMC5902

## 6CH Motor Driver for CD-ROM, DVD-ROM

### TYPICAL APPLICATION

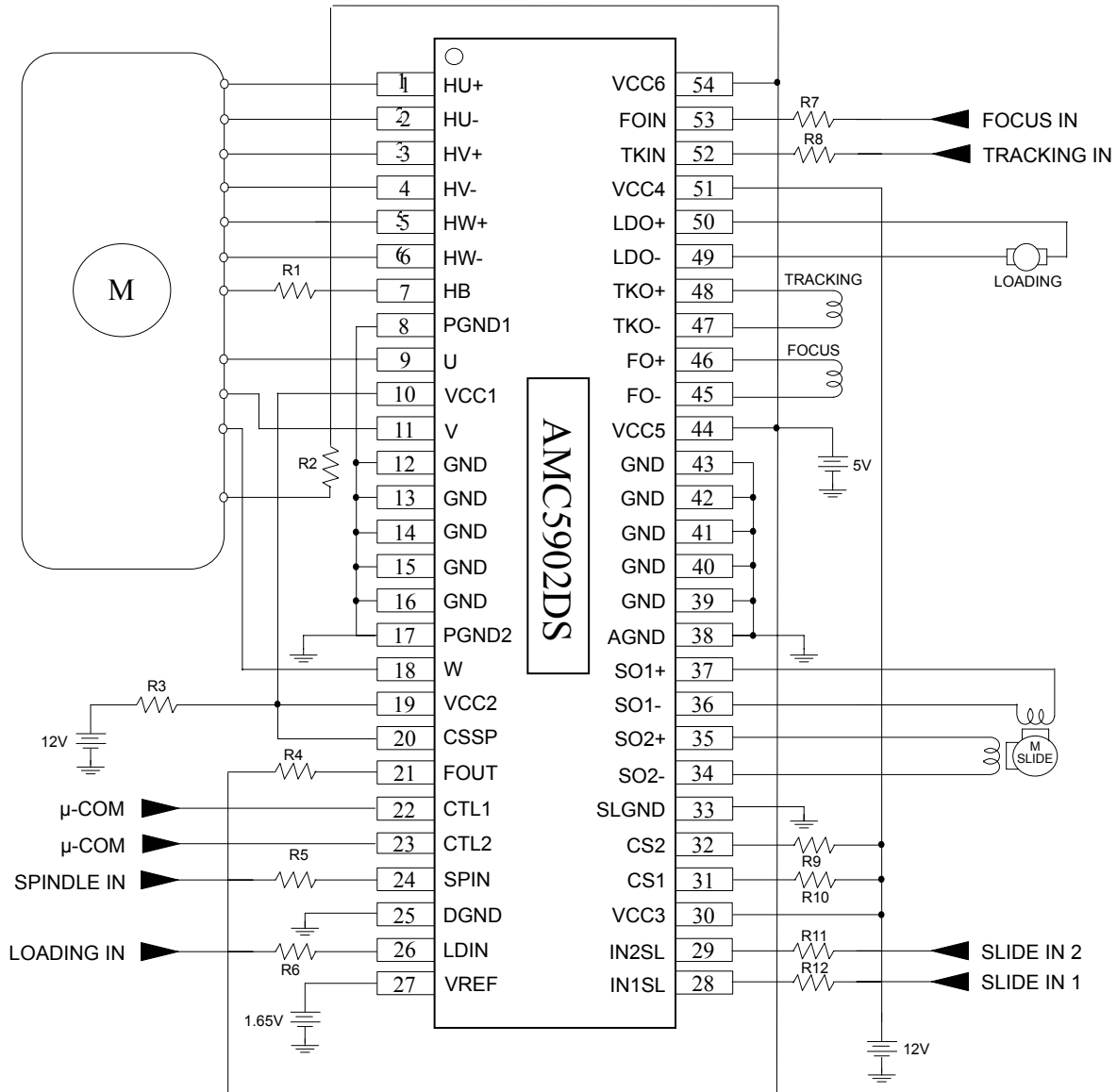

**Example values for external parts**

Part name	Value(typ)	Unit	Remark
R1	33	Ω	Depends on application
R2	100	Ω	Depends on application
R3	0.33	Ω	Ilim=1.42A,Gain=3.0A/V
R4	10k	Ω	Depends on application
R5	0	Ω	Depends on application.
R6	8.2k	Ω	Depends on application
R7	6.6k	Ω	Depends on application
R8	20k	Ω	Depends on application
R9, R10	1	Ω	Ilim=0.47A,Gain=0.47A/V
R11, R12	12k	Ω	Depends on application

# AMC5902

## 6CH Motor Driver for CD-ROM, DVD-ROM

ABSOLUTE MAXIMUM RATINGS (Note 1)			
Parameter	Symbol	Limits	Unit
POWER MOS power supply voltage	VCC1,VCC2,CS1,CS2	15	V
Preblock/BTL powerblock power supply voltage	VCC3,VCC4,VCC5	15	V
PWM control blockpower supply voltage	VCC6	7	V
Operating junction temperature	Tj	150	°C
Storage temperature range	Tstg	-40 to 150	°C
Lead Temperature (soldering, 10 seconds)		260	°C

Note 1: Exceeding these ratings could cause damage to the device. All voltages are with respect to Ground. Currents are positive into, negative out of the specified terminal.

RECOMMENDED OPERATING CONDITIONS					
Parameter	Symbol	Min	Typ.	Max	Unit
POWER MOS power supply voltage	VCC1,VCC2	-	VCC4	-	V
POWER MOS power supply voltage	CS1,CS2	-	VCC3	-	V
Internal block/BTL power block power supply voltage	VCC3,VCC4	VCC5	12	14	V
Power supply (for focus and tracking)	VCC5	4.3	5.0	VCC4	V
PWM control block power supply voltage	VCC6	4.3	5.0	6.0	V
Tracking, focus and loading output current	I <sub>O1</sub>	-	0.5	0.8	A
Spindle output current	I <sub>O2</sub>	-	1.2	*2.5	A
Slide output current	I <sub>O3</sub>	-	0.5	0.8	A
Focus/Tracking output current	I <sub>O4</sub>	-	0.5	0.8	A

\*The current is guaranteed 3.0A in case of the current is turned on/off in a duty ratio of an 1/10 with a maximum on time of 5msec.

THERMAL DATA					
Package	θ <sub>JA</sub> (°C/W)	Derating factor (mW/°C), T <sub>A</sub> ≥ 25°C	T <sub>A</sub> ≤ 25°C Power rating(mW)	T <sub>A</sub> = 70°C Power rating(mW)	T <sub>A</sub> = 85°C Power rating (mW)
DS	57.6	17.36	2200	1419	1158

Note:  $T_J = T_A + P_D \times \theta_{JA}$   
 P<sub>D</sub>: Power dissipation.  
 θ<sub>JA</sub>: Thermal resistance from Junction to Case.  
 D<sub>F</sub>: Derating factor, θ<sub>JA</sub> = 1 / D<sub>F</sub>

1. The θ<sub>JA</sub> numbers are guidelines for the thermal performance of the device/PC-board system.
2. All of the above assume no ambient airflow.
3. If power consumption is over above rating, adequate heat sink is required to dissipate heat.

**BLOCK DIAGRAM**

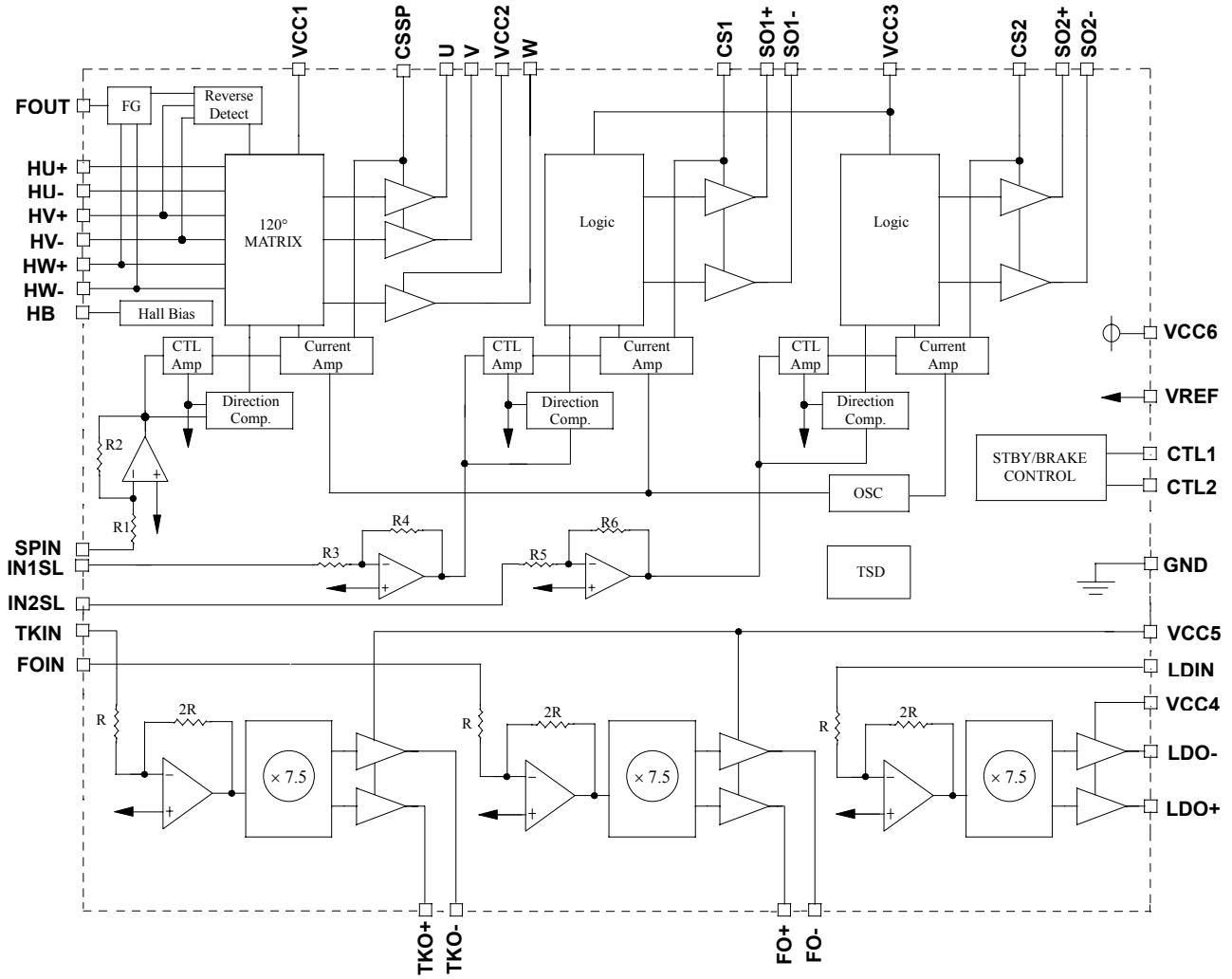

**Reference values for internal components**

Part name	Value(typ)	Unit
R1, R2	15k	Ω
R3, R4, R5, R6	47k	Ω
R	47k	Ω

# AMC5902

## 6CH Motor Driver for CD-ROM, DVD-ROM

PIN DESCRIPTION					
Pin No.	Pin Name	Pin Function	Pin No.	Pin Name	Pin Function
1	HU+	HU+ sensor Amp. input	54	VCC6	PWM block control power supply
2	HU-	HU- sensor Amp. input	53	FOIN	Focus control input
3	HV+	HV+ sensor Amp. input	52	TKIN	Tracking control input
4	HV-	HV- sensor Amp. input	51	VCC4	Motor power supply 4 (for loading)
5	HW+	HW+ sensor Amp. input	50	LDO+	Loading non-inverted output
6	HW-	HW- sensor Amp. input	49	LDO-	Loading inverted output
7	HB	Bias for Hall sensor	48	TKO+	Tracking non-inverted output
8	PGND1	Spindle driver power ground 1	47	TKO-	Tracking inverted output
9	U	Motor drive output U	46	FO+	Focus non-inverted output
10	VCC1	Motor power supply 1 (for spindle)	45	FO-	Focus inverted output
11	V	Motor drive output V	44	VCC5	5V Power supply (for focus, tracking)
12	GND	Ground	43	GND	Ground
13	GND	Ground	42	GND	Ground
14	GND	Ground	41	GND	Ground
15	GND	Ground	40	GND	Ground
16	GND	Ground	39	GND	Ground
17	PGND2	Spindle driver power ground 2	38	AGND	Ground
18	W	Motor drive output W	37	SO1+	Slide non-inverted output 1
19	VCC2	Motor power supply 1 (for spindle)	36	SO1-	Slide inverted output 1
20	CSSP	Spindle current sense	35	SO2+	Slide non-inverted output 2
21	FOUT	Frequency generator output	34	SO2-	Slide inverted output 2
22	CTL1	Control input 1	33	SLGND	Slide driver power ground
23	CTL2	Control input 2	32	CS2	Slide current sense 2
24	SPIN	Spindle control input	31	CS1	Slide current sense 1
25	DGND	PWM block pre-ground	30	VCC3	Motor power supply 3 (for slide)
26	LDIN	Loading control input	29	IN2SL	Slide control voltage input 2
27	VREF	Reference	28	IN1SL	Slide control voltage input 1

DC ELECTRICAL CHARACTERISTICS						
Unless otherwise specified, these specifications apply to operating ambient temperature $T_A = 25^\circ\text{C}$ , $V_{CC6} = V_{CC5} = 5\text{V}$ , $V_{CC3} = V_{CC4} = 12\text{V}$ , $V_{ref} = 1.65\text{V}$ , $R_{SP} = 0.33\ \Omega$ , $R_{SL1} = R_{SL2} = 0.5\ \Omega$ .						
Parameter	Symbol	Test Conditions	AMC5901			Units
			Min	Typ.	Max	
<b>Common Section</b>						
Quiescent current 1	IQ1	VCC4 (CTL1=L,CTL2=H)	-	18	23	mA
Quiescent current 2	IQ2	VCC4 (CTL1=H,CTL2=L)	-	14	16	mA
Quiescent current 3	IQ3	VCC6 (CTL1=L,CTL2=H)	-	3.5	4.9	mA
Standby-on current 1	IST1	VCC4 (CTL1=L,CTL2=L)	-	0.2	0.3	mA
Standby-on current 2	IST2	VCC6 (CTL1=L,CTL2=L)	-	-	0.1	mA

## AMC5902

### 6CH Motor Driver for CD-ROM, DVD-ROM

DC ELECTRICAL CHARACTERISTICS (continued)						
Unless otherwise specified, these specifications apply to operating ambient temperature $T_A = 25^\circ\text{C}$ , $V_{CC6} = V_{CC5} = 5\text{V}$ , $V_{CC3} = V_{CC4} = 12\text{V}$ , $V_{REF} = 1.65\text{V}$ , $R_{SP} = 0.33\ \Omega$ , $R_{SL1} = R_{SL2} = 0.5\ \Omega$ .						
Parameter	Symbol	Test Conditions	AMC5902			Units
			Min	Typ.	Max	
<b>Spindle Section</b>						
Control voltage dead zone	$V_{D\_SP}$		20	50	90	mV
Spindle gain control	$A_{V\_SP}$		0.8	1.0	1.2	V/V
	$G_{m\_SP}$	$R_{SP} = 0.33\ \Omega$	2.4	3.0	3.6	A/V
Spindle control limit	$V_{LIM\_SP}$	$I_{LIM\_SP} = V_{LIM\_SP} / R_S$	0.4	0.47	0.54	V
	$I_{LIM\_SP}$	$R_{SP} = 0.33\ \Omega$	1.2	1.42	1.64	A
Output ON resistor(upper)	$R_{ONUSP}$	$I_L = 0.5\text{A}$	-	0.6	1.0	$\Omega$
Output ON resistor(lower)	$R_{ONLSP}$	$I_L = -0.5\text{A}$	-	0.3	0.5	$\Omega$
PWM frequency	FOSC		-	110	-	KHz
Hall sensor common mode input range	$V_{CMH}$		1	-	4	V
Hall sensor differential input range	$V_{DIH}$		50	-	-	mV <sub>pp</sub>
HBIAS output voltage	$V_{OHB}$	$I_{HB} = 10\text{mA}$	0.7	1.15	1.6	V
HBIAS sink current	$I_{HB}$		-	1	5	$\mu\text{A}$
FOUT high voltage	$V_{FGH}$	100k $\Omega$ pull up to VCC6	-	4.9	-	V
FOUT low voltage	$V_{FGL}$		-	0.1	-	V
<b>Slide Section</b>						
Control voltage dead zone	$V_{D\_SL}$		15	40	65	mV
Slide gain control	$A_{V\_SL}$		0.4	0.5	0.6	V/V
	$G_{m\_SL}$	$R_S = 0.5\ \Omega$	0.8	1.0	1.2	A/V
Slide control limit	$V_{LIM\_SL}$	$I_{LIM\_SL} = V_{LIM\_SL} / R_S$	0.4	0.47	0.54	V
	$I_{LIM\_SL}$	$R_S = 0.5\ \Omega$	0.8	0.94	1.08	A
Output ON resistor(upper)	$R_{ONUSL}$	$I_L = 0.5\text{A}$	-	1.5	1.8	$\Omega$
Output ON resistor(lower)	$R_{ONLSL}$	$I_L = -0.5\text{A}$	-	0.75	1.0	$\Omega$
PWM frequency	FOSC		-	110	-	KHz
<b>Loading Section</b>						
Output offset voltage	$V_{OFF}$		-50	-	50	mV
Output saturation voltage "H"	$V_{\_SHLO}$	$I_L = 0.5\text{A}$ , VCC4-(OUT+)	-	1.1	1.4	V
Output saturation voltage "L"	$V_{\_SLLO}$	$I_L = -0.5\text{A}$ , (OUT-)-GND	-	0.46	0.8	V
Loading gain control	$A_{V\_LO}$		16.0	17.5	19.0	dB
<b>Focus / Tracking Section</b>						
Output offset voltage	$V_{OFF}$		-50	-	50	mV
Output saturation voltage "H"	$V_{\_SHFO}$	$I_L = 0.5\text{A}$ , VCC5-(OUT+)	-	0.45	0.8	V
Output saturation voltage "L"	$V_{\_SLFO}$	$I_L = -0.5\text{A}$ , (OUT-)-GND	-	0.45	0.8	V
Actuator gain control	$A_{V\_FO}$		16.0	17.5	19.0	dB
<b>CTL1,CTL2</b>						
Input high voltage	$V_H$		2.0	-	-	V
Input low voltage	$V_L$		-	-	0.5	V

# AMC5902

## 6CH Motor Driver for CD-ROM, DVD-ROM

Parameter	Symbol	Test Conditions	AMC5902			Units
			Min	Typ.	Max	
<b>Others</b>						
VREF drop muting			0.4	0.7	1.0	V
VCC4/VCC6 drop muting			3.4	3.8	4.2	V
<b>Thermal Characteristics</b>						
Thermal shut down temperature	$T_{SD\_OFF}$		-	150	-	°C
	$T_{SD\_ON}$		-	175	-	°C

### OUTPUT CIRCUIT

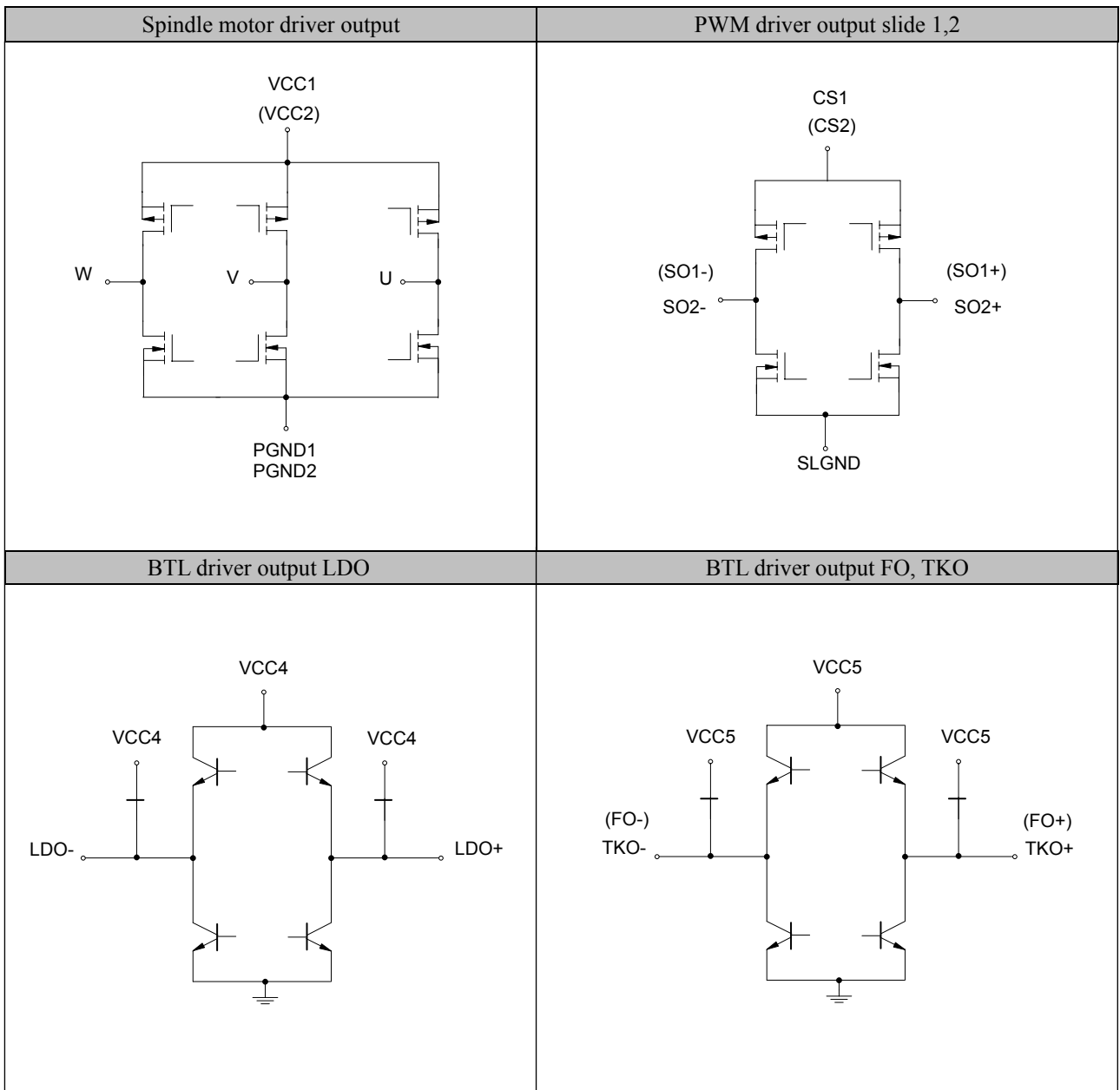

**APPLICATION INFORMATION**

**Spindle channel**

The spindle motor torque is controlled by the differential voltage of SPIN and VREF. The voltage gain,  $A_{V\_SP}$ , is 1.0(V/V).

The limitation function starts to take effect when the differential voltage of VCC1 and CSSP is over 0.47V.

Current gain is equal to  $A_{V\_SP} / R_{SP}$ .

**Slide channel**

The slide motor torque is controlled by the differential voltage of IN1SL (IN2SL) and VREF. The voltage gain,  $A_{V\_SL}$ , is 0.5(V/V).

The limitation function starts to take effect when the differential voltage of VCC3-CS1(CS2) is over 0.47V.

Current gain is equal to  $A_{V\_SL} / R_{SL}$ .

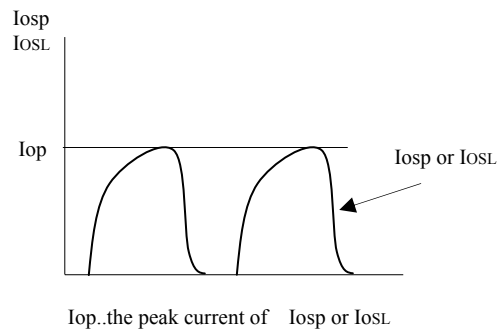
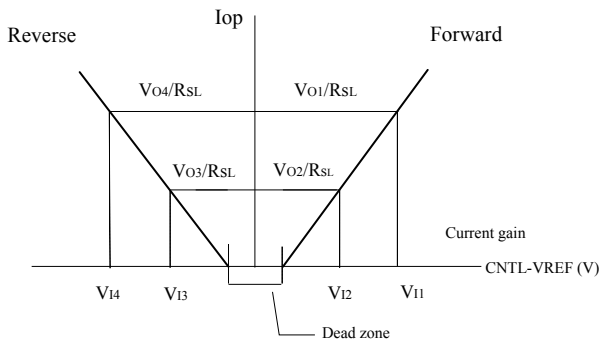

**Spindle driver**

$V_{11}=150\text{mV}, V_{12}=110\text{mV},$   
 $V_{14}=-150\text{mV}, V_{13}=-110\text{mV}$

$Gm(+)=(V_{01}-V_{02})/(150-110)/0.33$   
 $Gm(-)=(V_{04}-V_{03})/(150-110)/0.33$

**Slide driver**

$V_{11}=250\text{mV}, V_{12}=130\text{mV},$   
 $V_{14}=-250\text{mV}, V_{13}=-130\text{mV}$

$Gm(+)=(V_{01}-V_{02})/(250-130)/0.5$   
 $Gm(-)=(V_{04}-V_{03})/(250-130)/0.5$

**Gain expression**

	Spindle	Slide
Input-output gain $Gm(A/V)$	$1.0/R_{SP}$	$0.5/R_{SL}$
Output-limit current	$0.47/R_{SP}$	$0.47/R_{SL}$
Gain with the added resistor $Gm(A/V)$	$15k/[(R1+15k) \times R_{SP}]$	$0.5 \times 15k/[(R1+47k) \times R_{SL}]$

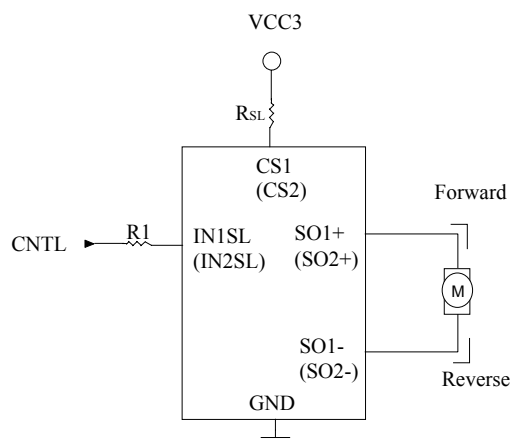
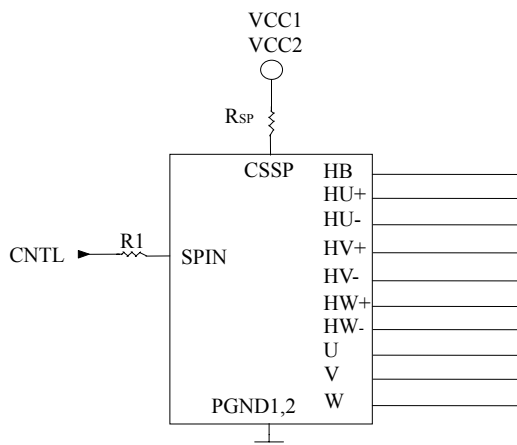



**APPLICATION INFORMATION (continued)**

**Loading control**

The loading output voltage is set internally to be  $7.5 \times (LDIN - VREF)$ .  
 With LDIN is higher/ equal/ lower to VREF, the motor can be set to Forward/ Short brake/ Reverse functions..

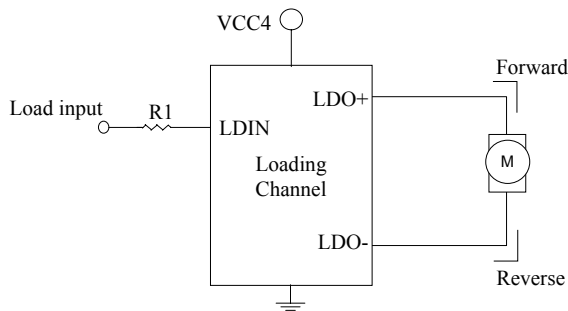

**Focus / tracking channel**

The focus and tracking output voltage is set internally to be  $7.5 \times (FOIN - VREF)$ .  
 With FOIN (TKIN) is higher/ equal/ lower to VREF, the motor can be set to Forward/ Short brake/ Reverse function.

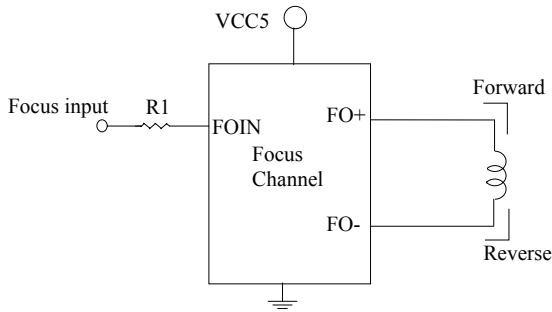

**Gain expression**

	Gain with the added resistor $A_v(V/V)$
Loading (LO+ - LO-)	$7.5 \times 47k / (R1 + 47k)$
Focus (FO+ - FO-)	$7.5 \times 47k / (R1 + 47k)$
Tracking (TKO+ - TKO-)	$7.5 \times 47k / (R1 + 47k)$

**APPLICATION INFORMATION (continued)**

**Table of chip control function**

1. Circuit control terminal 1 and 2 (CTL1-pin22 and CTL2-pin23)

The device can be set to standby mode to reduce power dissipation, and spindle-driver braking mode can be switch on/off by inputting combinations of on/off to these terminals.

CTL1	CTL2	Spindle	Slide	Focus	Tracking	Loading
L	L	X	X	X	X	X
H	L	X	X	X	X	O
-	H	O	O	O	O	X

O...ON X...OFF

CTL1	CTL2	SPIN > VREF	SPIN < VREF
L	H	Forward-rotation mode	Reverse-rotation braking mode
H	H	Forward-rotation mode	Short-circuit braking mode

1.1 Reverse-rotation braking mode (spindle)

A reverse-rotation torque is applied when SPIN < VREF.

Reverse-rotation is detected with SPIN input and Hall input. If the spindle detects reverse rotation when SPIN < VREF, all outputs are shorted out to GND.

1.2 Short-circuit braking mode (spindle)

All the spindle driver outputs are shorted out to GND when SPIN < VREF.

1.3 Standby mode

The IC is brought into standby mode, and its power dissipation can be limited.

1.4 Driving muting

All the output channels except the loading are muted and their outputs are turn off

2. Muting functions

2.1 Over voltage protection circuit

When the voltage at VCC4 terminal drops to upper than 15.5V(typ.), the output of only the spindle block is turned off.

2.2 VCC4/VCC6-drop muting

When the voltages at VCC4 terminal and VCC6 terminal drop to lower than 3.8V(typ.), the outputs of all the channels are turned off.

2.3 VREF-drop muting

When the voltage at VREF terminal drops to a value lower than 0.7V(typ.), the outputs of all the channels are turned off. Set the VREF terminal voltage to larger than 1.0V.

3 PWM oscillation frequency

The PWM oscillation for driving the spindle and slide is free running. The oscillation frequency is 100kHz(typ.).

4. FOUT function

The FOUT terminal outputs the square pulse signal synchronizing with the Hall inputs (HW+, HW-) timing. The FOUT terminal is an open-collector output.

**APPLICATION INFORMATION (continued)**

5. The waveforms between U V W output-current and hall-amplifier-input

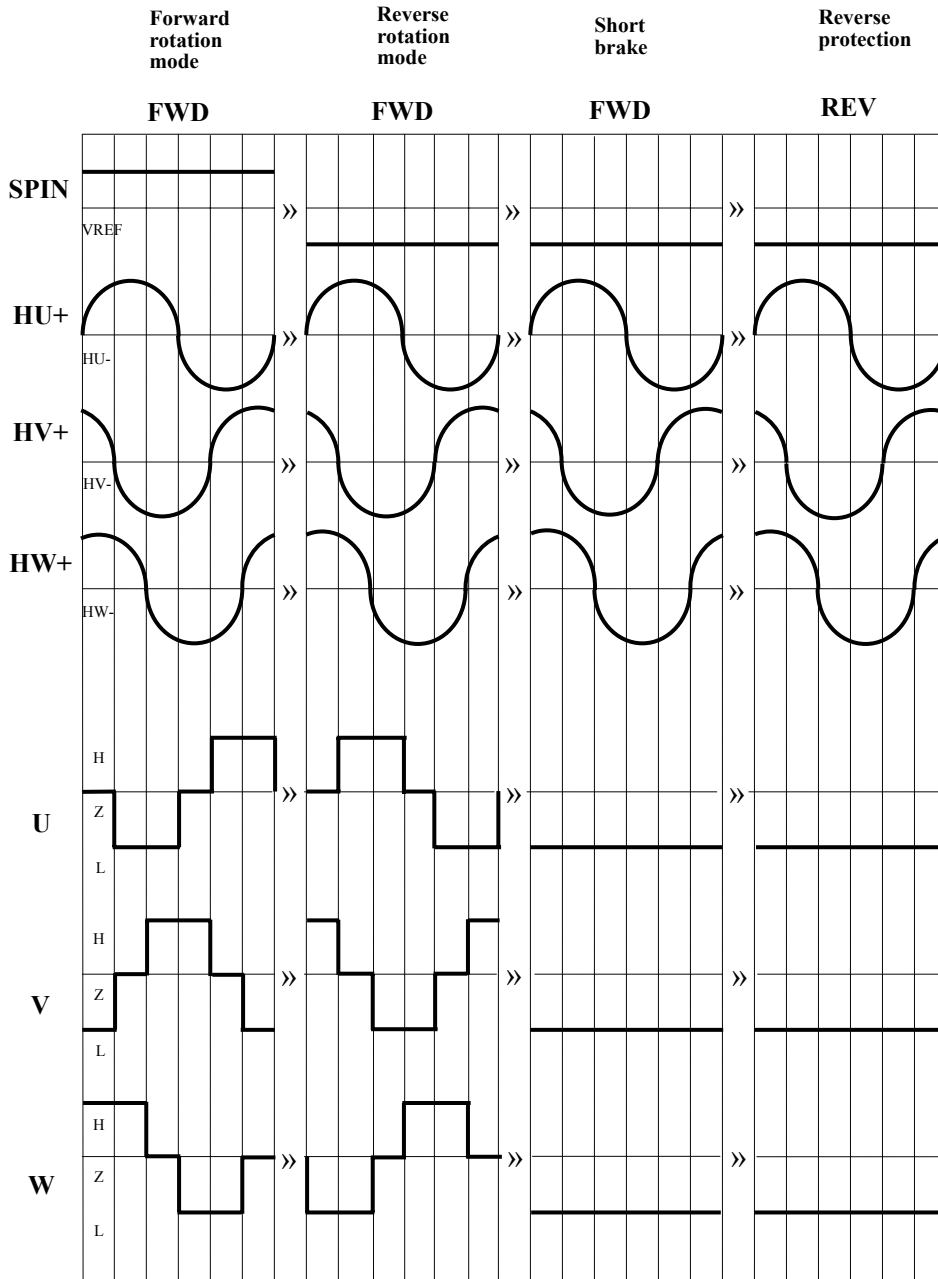

**APPLICATION INFORMATION (continued)**

When power dissipation is over 1.4W ( $T_A=70^\circ\text{C}$ ), additioned heat sink is required to control chip junction temperature below  $150^\circ\text{C}$ . The power TSOP package has 10 GND pins connected to internal leadframe pad for enhanced power dissipation (12-16,39-43) performance.

Using bigger area of ground plane (as heat sink) can reduce chip temperature significantly.

$$T_J = T_A + P_D (\theta_{JC} + \theta_{CA})$$

For power TSOP package,  $\theta_{JC} = 6.1^\circ\text{C} / \text{W}$

For further improvement of heat problem, extra heat sink can be used by clipping it to the thermal pad on the top.

**APPLICATION INFORMATION (continued)**

**54-Lead Thin Small Outline Plakage (TSOP)**

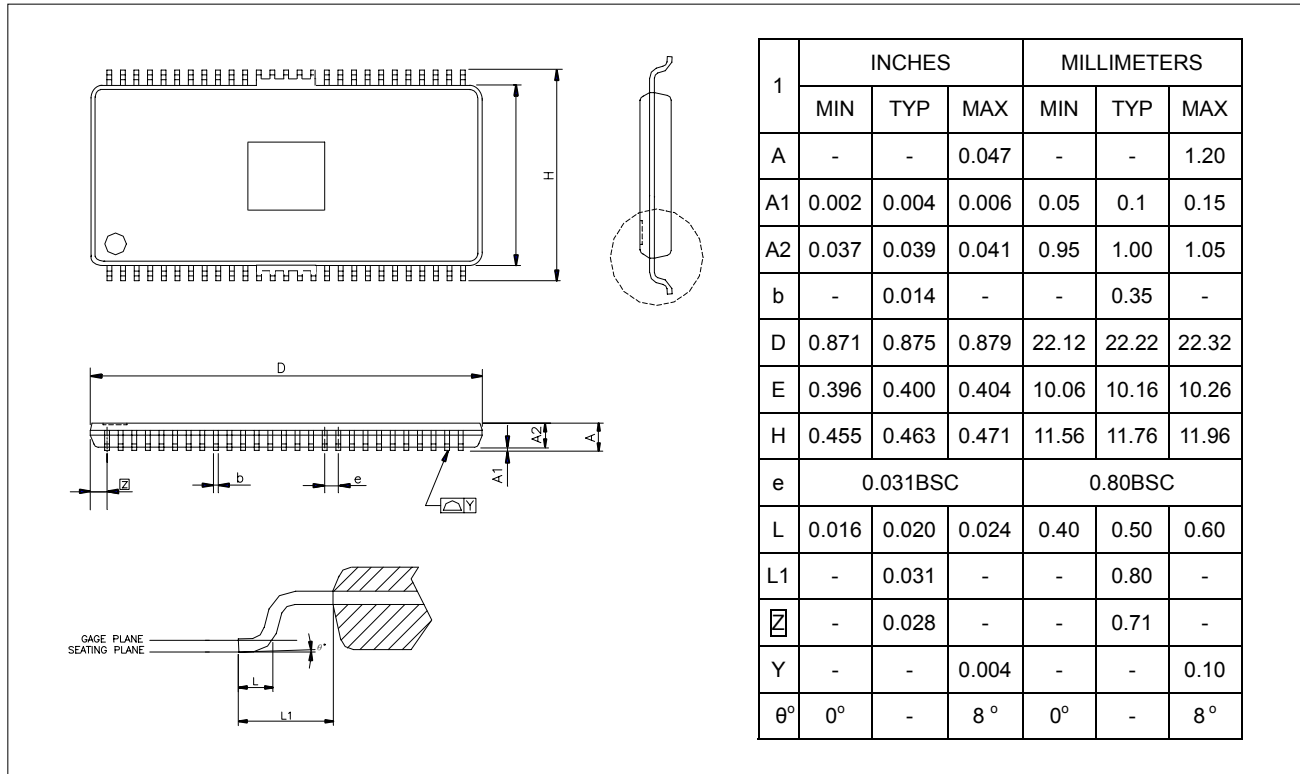

**IMPORTANT NOTICE**

ADD Microtech (ADDM) reserves the right to make changes to its products or to discontinue any integrated circuit product or service without notice, and advises its customers to obtain the latest version of relevant information to verify, before placing orders, that the information being relied on is current.

A few applications using integrated circuit products may involve potential risks of death, personal injury, or severe property or environmental damage. ADDM integrated circuit products are not designed, intended, authorized, or warranted to be suitable for use in life-support applications, devices or systems or other critical applications. Use of ADDM products in such applications is understood to be fully at the risk of the customer. In order to minimize risks associated with the customer's applications, the customer should provide adequate design and operating safeguards.

ADDM assumes no liability to customer product design or application support. ADDM warrants the performance of its products to the specifications applicable at the time of sale.

**U.S.**

**ADD Microtech Inc.**  
**492 Altamont Drive**  
**Milpitas, CA 95035**

TEL: (408) 9410420  
FAX: (408) 9410864

**Asia Pacific region**

**ADD Microtech Corp**  
13F, 287, Sec 3, Nan Jin E. Road  
Taipei, Taiwan

TEL: 2-27132800  
FAX: 2-27132805