

AMC DOC. #: AMC7584_E (LF)
Feb 2005



AMC7584 7A LOW DROPOUT REGULATOR

DESCRIPTION	FEATURES
<p>The AMC7584 series is a high performance low dropout regulator rated for 7A output current. It is designed for use in applications requiring low dropout characteristics over rated current range. The AMC7584 series offers fixed 2.5V, 3.3V, 5V and adjustable output voltage versions. In addition, the AMC7584 series features the device protections including over current and thermal shutdown. Also, reverse battery protection scheme limits the reverse current when the input voltage falls below the output.</p>	<ul style="list-style-type: none"> ■ Input-Output differential of typical 1.1V at 7A and low quiescent current ■ Output current is excess of 7A □ Reverse battery protection □ Short circuit protection □ Internal thermal overload protection □ Available in 3L plastic TO-220 and surface mount 3L TO-263 packages □ Pin assignment identical to EZ1585B and LT1585A series.

APPLICATIONS	PACKAGE PIN OUT
--------------	-----------------

- Pentium® Processor Supplies
- PowerPC™ Supplies
- Computer Add-On Cards
- Other Applications Requiring Low Dropout Voltage Over Rated Current.

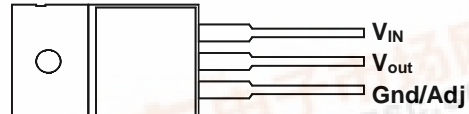

3-Pin Plastic TO-220
(Top View)

- AMC7584-2.5 – 2.5V Fixed
- AMC7584-3.3 – 3.3V Fixed
- AMC7584-5.0 – 5.0V Fixed
- AMC7584-ADJ– Adjustable

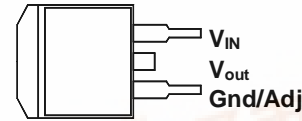

3-Pin Plastic TO-263
Surface Mount
(Top View)

ORDER INFORMATION			
T _A (°C)	T	Plastic TO-220	ST Plastic TO-263
		3-pin	3-pin
0 to 70		AMC7584-XXT	AMC7584-XXST
0 to 70		AMC7584-XXTF (Lead Free)	AMC7584-XXSTF (Lead Free)
0 to 70		AMC7584-ADJT	AMC7584-ADJST
0 to 70		AMC7584-ADJTF (Lead Free)	AMC7584-ADJSTF (Lead Free)

Note: 1. All surface-mount packages are available in Tape & Reel. Append the letter "T" to part number (i.e., AMC7584-X.XSTT).
2. The letter "F" is marked for Lead Free process.

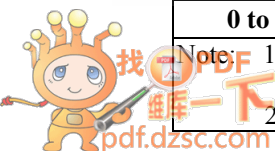

TYPICAL APPLICATION

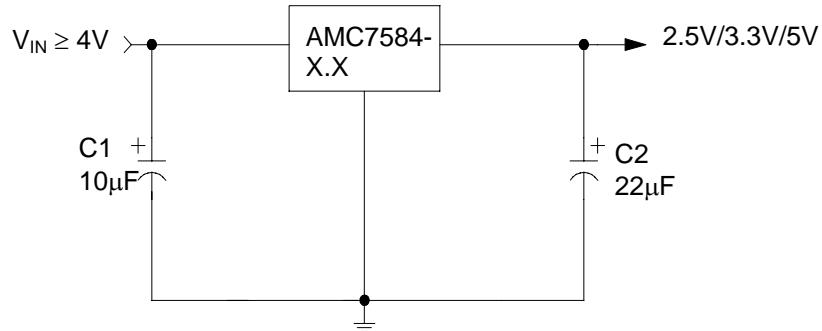

AMC7584-X.X application schematic

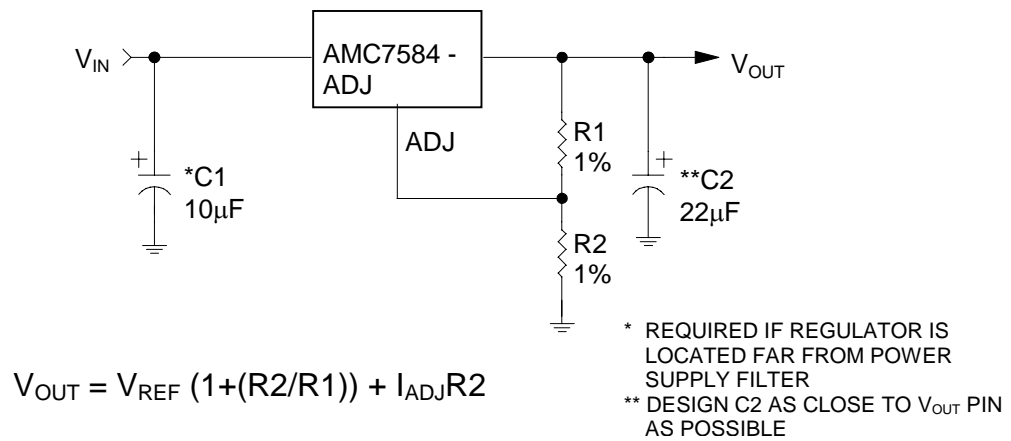

AMC7584-ADJ application schematic

ABSOLUTE MAXIMUM RATINGS (Note 1)	
Input Voltage (V_{IN})	7V
Operating Junction temperature	150°C
Storage Temperature Range	-65°C to 150°C
Lead temperature (Soldering, 10 seconds)	300°C
Note 1: Exceeding these ratings could cause damage to the device. All voltages are with respect to Ground. Currents are positive into, negative out of the specified terminal.	

THERMAL DATA	
T, ST PACKAGE:	
Thermal Resistance-Junction to Tab, θ_{JT}	3.0°C/W
Thermal Resistance-Junction to Ambient, θ_{JA}	45°C/W
The θ_{JA} numbers are guidelines for the thermal performance of the device/pc-board system. $T_J = T_A + (P_D \times \theta_{JA})$, all of the above assume no ambient airflow.	

BLOCK DIAGRAM

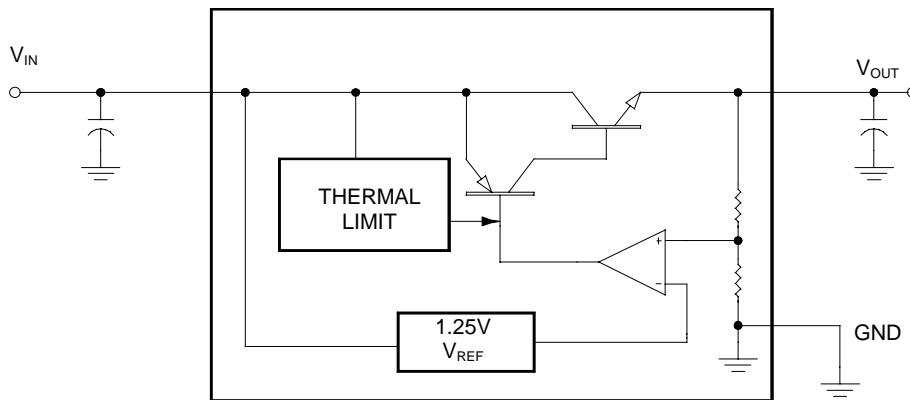

AMC7584-X.X circuit schematic

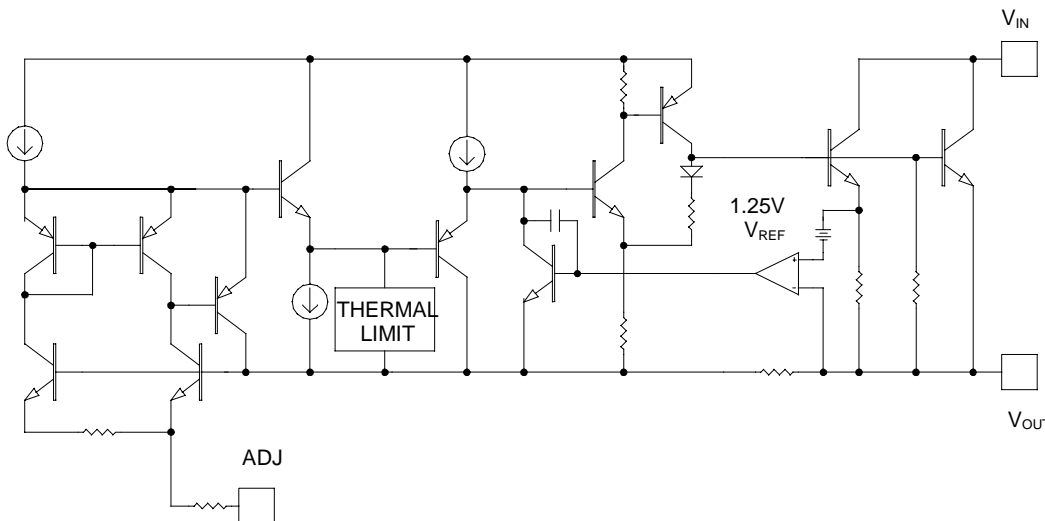

AMC7584-ADJ circuit schematic

RECOMMENDED OPERATING CONDITIONS					
Parameter	Symbol	Recommended Operating Conditions			Units
		Min.	Typ.	Max.	
Input Voltage	V_{IN}	4.0		7	V
Load Current (with adequate heatsinking)	I_o	0.010		7	A
Input Capacitor (V_{IN} to GND)		1.0			μ F
Output Capacitor with ESR of 10 Ω max., (V_{OUT} to GND)		10			μ F

ELECTRICAL CHARACTERISTICS							
Unless otherwise specified, these specifications apply over the operating ambient temperature of 0°C to +70°C for AMC7584; $I_o = 10\text{mA}$, $C_{OUT} = 10\ \mu\text{F}$, and are for DC characteristics only. (Low duty cycle pulse testing techniques are used which maintains junction and case temperatures equal to the ambient temperature.)							
Parameter	Symbol	Test Conditions	AMC7584			Units	
			Min.	Typ.	Max.		
Output Voltage	AMC7584-2.5	$V_{IN} = 4\text{V}, T_A = 25^\circ\text{C}$ $V_{IN} = V_{OUT} + 2\text{V}, T_A = 25^\circ\text{C}$	2.475	2.500	2.525	V	
	AMC7584-3.3		3.267	3.300	3.333		
	AMC7584-5.0		4.950	5.000	5.050		
Reference Voltage	AMC7584-ADJ	V_{REF} $I_o = 10\ \text{mA to } 7\text{A}$	1.238	1.250	1.262	V	
			1.230	1.250	1.270		
Line Regulation (Note 2)	ΔV_{OI}	$4\text{V} \leq V_{IN} \leq 7\text{V}$		0.005	0.2	%	
Load regulation (Note 2)	AMC7584-2.5	ΔV_{OL} $V_{IN} = 4\text{V}, 10\text{mA} \leq I_o \leq 7\text{A}$ $V_{IN} = V_{OUT} + 2\text{V}, 10\text{mA} \leq I_o \leq 7\text{A}$				%	
	AMC7584-3.3			0.05	0.2		
	AMC7584-5.0						
	AMC7584-ADJ						
Dropout Voltage	ΔV	$4\text{V} \leq V_{IN} \leq 7\text{V}$	$I_o = 100\text{mA}$	0.010	0.030	V	
			$I_o = 7\text{A}$	1.100	1.300		
Quiescent Current	I_Q	$4\text{V} \leq V_{IN} \leq 7\text{V}, 100\text{mA} \leq I_o \leq 7\text{A}$		8	13	mA	
Adj pin current (AMC7584-ADJ only)	I_{ADJ}	$4\text{V} \leq V_{IN} \leq 7\text{V}, 100\text{mA} \leq I_o \leq 7\text{A}$		50	120	μ A	
Current Limit	I_{CL}	$4\text{V} \leq V_{IN} \leq 7\text{V}$	7	8		A	
Output Noise Voltage (Note 3)	$V_{O\text{RMS}}$	10Hz – 100kHz, $I_o = 5\text{mA}$		150		μV_{RMS}	
Long Term Stability (Note 3)				20		mV/1000hr	
Ripple rejection (Note 3)	R_R	$f_o = 120\text{Hz}, 1\text{V}_{\text{RMS}}, I_o = 100\text{mA}$		66		dB	
Note 2: Line and load regulation is guaranteed up to maximum power dissipation determined by input/output differential and the output current. However, the maximum power will not be available over the full input/output voltage range.							
Note 3: These parameters, although guaranteed, are not tested in production prior to shipment							

APPLICATION INFORMATION:

• **Thermal Consideration**

Maximum Power Calculation:

$$P_{D(MAX)} = \frac{T_{J(MAX)} - T_{A(MAX)}}{\theta_{JA}}$$

$T_J(^{\circ}C)$: Maximum recommended junction temperature

$T_A(^{\circ}C)$: Ambient temperature of the application

$\theta_{JA}(^{\circ}C/W)$: Junction-to-junction temperature thermal resistance of the package, and other heat dissipating materials.

The maximum power dissipation of a single-output regulator :

$$P_{D(MAX)} = [(V_{IN(MAX)} - V_{OUT(NOM)}) \times I_{OUT(NOM)} + V_{IN(MAX)} \times I_Q]$$

Where: $V_{OUT(NOM)}$ = the nominal output voltage

$I_{OUT(NOM)}$ = the nominal output current, and

I_Q = the quiescent current the regulator consumes at $I_{OUT(MAX)}$

$V_{IN(MAX)}$ = the maximum input voltage

Then $\theta_{JA} = (150^{\circ}C - T_A) / P_D$

Thermal consideration:

When power consumption is over about 1.2W(at 70°C ambient temperature), additional heat sink is required to control the junction temperature below 125 °C.

The junction temperature is: $T_j = P_D (\theta_{JT} + \theta_{CS} + \theta_{SA}) + T_A$

P_D :Dissipated power.

θ_{JT} :Thermal resistance from the junction to the mounting tab of the package.

θ_{CS} : Thermal resistance through the interface between the IC and the surface on which it is mounted. (typically, $\theta_{CS} < 1.0^{\circ}C / W$)

θ_{SA} :Thermal resistance from the mounting surface to ambient (thermal resistance of the heat sink).

If PC Board copper is going to be used as a heat sink, below table can be used to determine the appropriate size of copper foil required. For multi-layered PCB, these layers can also be used as a heat sink. They can be connected with several through hole vias.

PCB $\theta_{SA} (^{\circ}C / W)$	59	45	38	33	27	24	21
PCB heat sink size (mm ²)	500	1000	1500	2000	3000	4000	5000

Recommended figure of PCB area used as a heat sink.

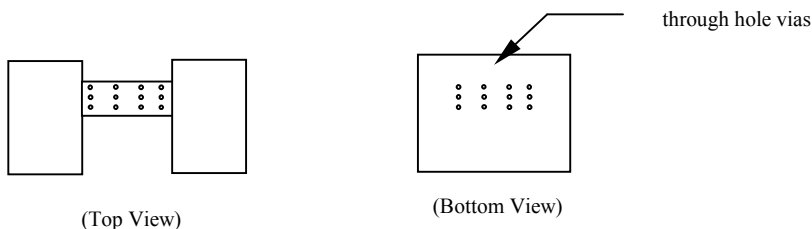

3-Pin Plastic TO-220 (T)

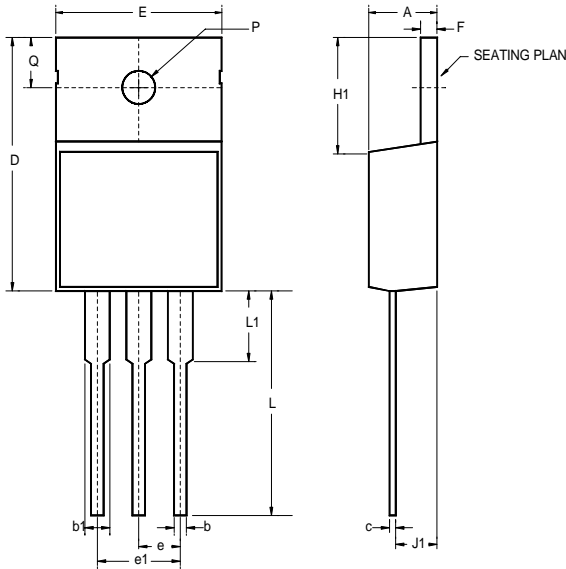

	INCHES			MILLIMETERS		
	MIN	TYP	MAX	MIN	TYP	MAX
A	0.140	-	0.190	3.56	-	4.83
b1	0.045	-	0.070	1.14	-	1.78
b	0.020	-	0.045	0.51	-	1.14
c	0.012	-	0.045	0.30	-	1.14
D	0.560	-	0.650	14.22	-	16.51
E	0.380	-	0.420	9.65	-	10.67
e	0.090	-	0.110	2.29	-	2.79
e1	0.190	-	0.210	4.83	-	5.33
F	0.020	-	0.055	0.51	-	1.40
H1	0.230	-	0.270	5.84	-	6.86
J1	0.080	-	0.115	2.03	-	2.92
L	0.500	-	0.580	12.7	-	14.73
P	0.139	-	0.161	3.53	-	4.09
Q	0.100	-	0.135	2.54	-	3.43
L1	-	-	0.250	-	-	6.35

3-Pin Surface Mount TO-263 (ST)

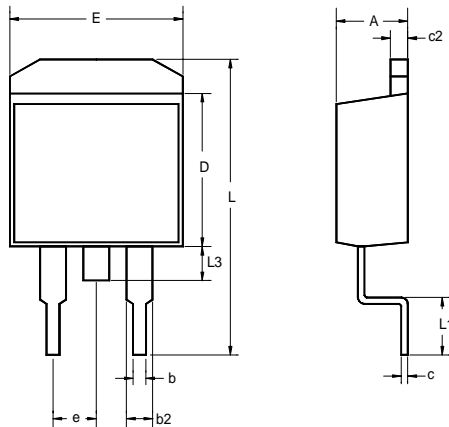

	INCHES			MILLIMETERS		
	MIN	TYP	MAX	MIN	TYP	MAX
A	0.160	-	0.190	4.06	-	4.83
b	0.020	-	0.039	0.51	-	0.99
b2	0.045	-	0.055	1.14	-	1.40
c	0.015 TYP.			0.38 TYP.		
c2	0.045	-	0.055	1.14	-	1.40
D	0.340	-	0.380	8.64	-	9.65
E	0.380	-	0.405	9.65	-	10.29
e	0.100 BSC			2.54 BSC		
L	0.575	-	0.625	14.61	-	15.88
L1	0.090	-	0.110	2.29	-	2.79
L2	-	-	0.115	-	-	2.92
L3	0.050	-	0.070	1.27	-	1.78

AMC DOC. #: AMC7584_D (LF)

March 2004

AMC7584

7A LOW DROPOUT REGULATOR

IMPORTANT NOTICE

ADD Microtech (ADDM) reserves the right to make changes to its products or to discontinue any integrated circuit product or service without notice, and advises its customers to obtain the latest version of relevant information to verify, before placing orders, that the information being relied on is current.

A few applications using integrated circuit products may involve potential risks of death, personal injury, or severe property or environmental damage. ADDM integrated circuit products are not designed, intended, authorized, or warranted to be suitable for use in life-support applications, devices or systems or other critical applications. Use of ADDM products in such applications is understood to be fully at the risk of the customer. In order to minimize risks associated with the customer's applications, the customer should provide adequate design and operating safeguards.

ADDM assumes no liability to customer product design or application support. ADDM warrants the performance of its products to the specifications applicable at the time of sale.

U.S.

ADD Microtech Inc.

492 Altamont Drive
Milpitas, CA 95035

TEL: (408) 9410420

FAX: (408) 9410864

Asia Pacific region

ADD Microtech Corp

13F, NO. 287, Sec. 3, Nan Jing E. Rd.,
Taipei, Taiwan 105

TEL: 2-27132800

FAX: 2-27132805
