



# Analog Microelectronics, Inc.

## AME1084

## 5A Low Dropout Positive Voltage Regulator

### General Description

The AME1084 is a 5A low-dropout positive voltage regulator. It is available in fixed and adjustable output voltage versions. Overcurrent and thermal protection are integrated onto the chip. Output current will limit as it reaches the pre-set current or temperature limit. At full rated output current the dropout voltage is 1.4V (max.). AME1084 series regulators provide excellent regulation over line, load and temperature variations.

### Key Features

- Low dropout voltage ... 1.4V at 5A
- Adjustable or 3.3V fixed voltage
- Line regulation typically 0.015%
- Load regulation typically 0.05%
- Adjust pin (ADJ) current less than 90 $\mu$ A
- Overcurrent protection
- Thermal protection
- Available in TO-220, TO-263, TO-252

### Applications

- High Efficiency Linear Regulators
- Post Regulators for Switching Supplies
- 5V to 3.3V Voltage Converter
- Battery Charger

### Functional Block Diagram

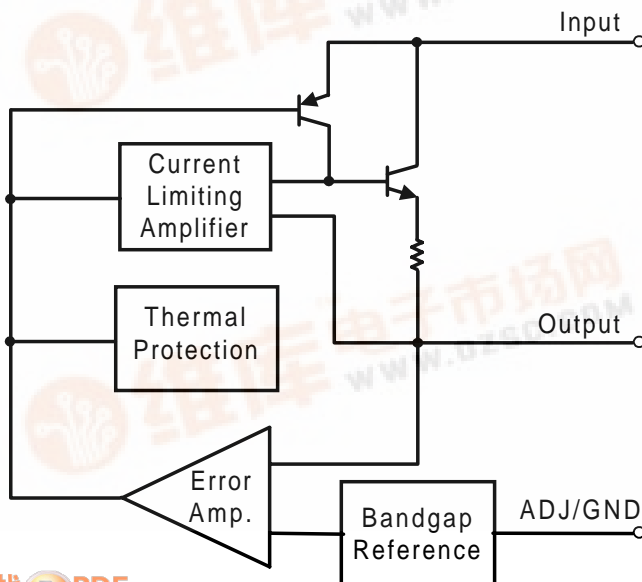

Figure 1

### Typical Application

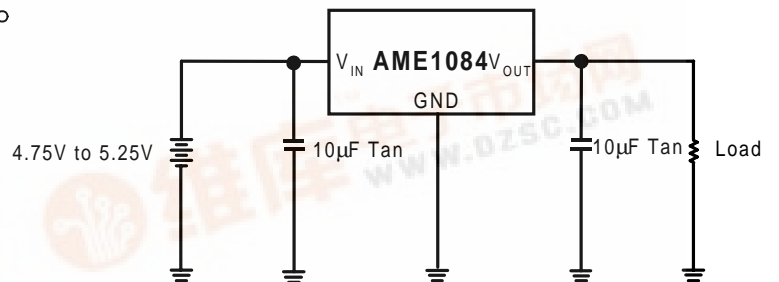
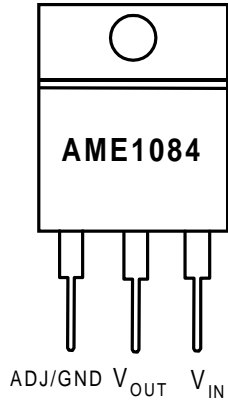

Figure 2





■ Pin Configuration



TO-220 Front View

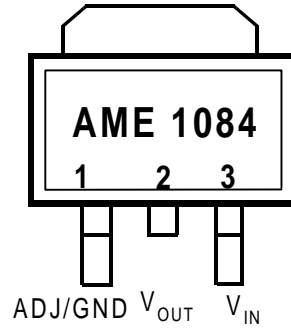

To-252 Front View

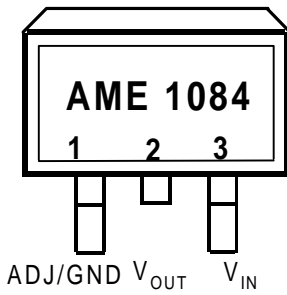

TO-263-2 Front View

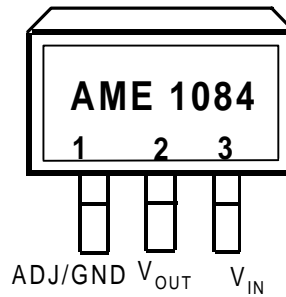

TO-263-3 Front View



■ Ordering Information

Part Number	Marking	Output Voltage	Package
AME1084ACBT	AME1084 ACBT yyww	ADJ	TO-220
AME1084BCBT	AME1084 BCBT yyww	1.5	TO-220
AME1084CCBT	AME1084 CCBT yyww	2.5	TO-220
AME1084DCBT	AME1084 DCBT yyww	3.3	TO-220
AME1084ACDT-3	AME1084 ACDT-3 yyww	ADJ	TO-263-3
AME1084BCDT-3	AME1084 BCDT-3 yyww	1.5	TO-263-3
AME1084CCDT-3	AME1084 CCDT-3 yyww	2.5	TO-263-3
AME1084DCDT-3	AME1084 DCDT-3 yyww	3.3	TO-263-3
AME1084ACDT	AME1084 ACDT yyww	ADJ	TO-263-2
AME1084BCDT	AME1084 BCDT yyww	1.5	TO-263-2
AME1084CCDT	AME1084 CCDT yyww	2.5	TO-263-2
AME1084DCDT	AME1084 DCDT yyww	3.3	TO-263-2
AME1084ACCS	AME1084 ACCS yyww	ADJ	TO-252
AME1084BCCS	AME1084 BCCS yyww	1.5	TO-252
AME1084CCCS	AME1084 CCCS yyww	2.5	TO-252
AME1084DCCS	AME1084 DCCS yyww	3.3	TO-252



■ Absolute Maximum Ratings

Parameter	Symbol	Maximum	Unit
Input Voltage	$V_{IN}$	7	V
Thermal Resistance (Junction to Case)	$\theta_{JC}$	TO-220	3
		TO-252	5
		TO-263	3
Thermal Resistance (Junction to Ambient)	$\theta_{JA}$	TO-220	50
		TO-252	90
		TO-263	50
Operating Junction Temperature Range	$T_J$	0 to 125	°C
Storage Temperature Range	$T_{STG}$	-65 to 150	
Lead Temperature (10 sec)	$T_{LEAD}$	260	



■ Electrical Characteristics

1. 1084AXXX

Parameter	Symbol	Test Conditions	Min.	Typ.	Max.	Units	
Reference voltage (adjustable voltage)	$V_{REF}$	$V_{IN} = 5V$ $I_O = 10mA$	$T_J = 25^{\circ}C$	1.238	1.250	1.262	V
			Over temp.	1.225		1.275	
Line regulation	$Reg_{LINE}$	$V_{IN} = 2.75 - 7V$ $I_O = 10mA$	$T_J = 25^{\circ}C$	-	0.015	0.2	%
			Over temp.	-	0.035	0.2	
Load regulation	$Reg_{LOAD}$	$V_{IN} = 5V$ $I_O = 10mA - 5A$	$T_J = 25^{\circ}C$	-	0.05	0.3	%
			Over temp.	-	0.2	0.4	
Dropout voltage $\Delta V_{OUT}, \Delta V_{REF} = 1\%$	$V_D$	$V_{IN} = 2.75 - 7V$ $I_O = 10mA - 5A$	$T_J = 25^{\circ}C$	-	1.2	1.4	V
			Over temp.	-	1.3	-	
Current limit	$I_S$	$V_{IN} = 2.75 - 7V$ , Over temp.	5.0	-	-	A	
Temperature Coefficient	$T_C$	$V_{IN} = 2.75 - 7V$ , $I_O = 10mA - 5A$	-	0.005	-	$\%/^{\circ}C$	
Adjust pin current	$I_{ADJ}$	$V_{IN} = 2.75 - 7V$ $I_O = 10mA - 5A$	$T_J = 25^{\circ}C$	-	55	-	$\mu A$
			Over temp.	-	-	90	
Adjust pin current change	$\Delta I_{ADJ}$	$V_{IN} = 2.75 - 7V$ , $I_O = 10mA - 5A$ Over temp.	-	0.2	5		
Temperature stability	$T_S$	$V_{IN} = 5V$ , $I_O = 500mA$ , Over temp.	0.5	0.5	-	%	
Minimum load current	$I_O$	$V_{IN} = 5V$	-	5	10	mA	
RMS output noise	$V_N$	$T_J = 25^{\circ}C$	-	0.003	-	$\%V_O$	
Ripple rejection ratio	$R_A$	$V_{IN} = 5V$ , $I_O = 5A$ , Over temp.	60	72	-	dB	

2. 1084DXXX

Parameter	Symbol	Test Conditions	Min.	Typ.	Max.	Units	
Output voltage (fixed voltage)	$V_O$	$V_{IN} = 5V$ $I_O = 0A$	$T_J = 25^{\circ}C$	3.267	3.300	3.333	V
			Over temp.	3.234		3.366	
Line regulation	$Reg_{LINE}$	$V_{IN} = 4.5 - 7V$ $I_O = 0A$	$T_J = 25^{\circ}C$	-	0.015	0.2	%
			Over temp.	-	0.035	0.2	
Load regulation	$Reg_{LOAD}$	$V_{IN} = 5V$ $I_O = 0A - 5A$	$T_J = 25^{\circ}C$	-	0.05	0.3	%
			Over temp.	-	0.2	0.4	
Dropout voltage $\Delta V_{OUT}, \Delta V_{REF} = 1\%$	$V_D$	$V_{IN} = 4.5 - 7V$ $I_O = 0A - 5A$	$T_J = 25^{\circ}C$	-	1.2	1.4	V
			Over temp.	-	1.3	-	
Current limit	$I_S$	$V_{IN} = 4.5 - 7V$ , Over temp.	5.0	-	-	A	
Quiescent current (fixed model)	$I_Q$	$V_{IN} = 5V$ , $I_O = 0 - 5A$ , Over temp.	-	12	13	mA	
Temperature Coefficient	$T_C$	$V_{IN} = 4.5 - 7V$ , $I_O = 0A - 5A$	-	0.005	-	$\%/^{\circ}C$	
Temperature stability	$T_S$	$V_{IN} = 5V$ , $I_O = 500mA$ , Over temp.	0.5	0.5	-	%	
RMS output noise	$V_N$	$T_J = 25^{\circ}C$	-	0.003	-	$\%V_O$	
Ripple rejection ratio	$R_A$	$V_{IN} = 5V$ , $I_O = 5A$ , Over temp.	60	72	-	dB	



### Application Description

#### 1. Output voltage adjustment

Like most regulators, the AME1084 regulates the output by comparing the output voltage to an internally generated reference voltage. On the adjustable version, the  $V_{REF}$  is available externally as 1.25V between  $V_{OUT}$  and ADJ. The voltage ratio formed by  $R1$  and  $R2$  should be set to conduct 10mA (minimum output load). The output voltage is given by the following equation:

$$V_{OUT} = V_{REF} \left( 1 + \frac{R2}{R1} \right) + I_{ADJ} \times R2$$

On fixed versions of AME1084, the voltage divider is provided internally.

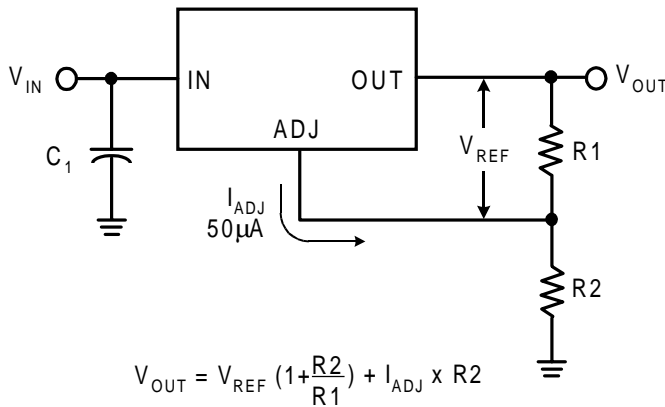

$$V_{OUT} = V_{REF} \left( 1 + \frac{R2}{R1} \right) + I_{ADJ} \times R2$$

Figure 3

#### 2. Thermal protection

AME1084 has thermal protection which limits junction temperature to 150°C. However, device functionality is only guaranteed to a maximum junction temperature of +125°C.

The power dissipation and junction temperature for AME1084 in TO-220 package are given by

$$P_D = (V_{IN} - V_{OUT}) \times I_{OUT}$$

$$T_{JUNCTION} = T_{AMBIENT} + (P_D \times \theta_{JA})$$

Note:  $T_{JUNCTION}$  must not exceed 125°C

#### 3. Current limit protection

AME1084 is protected against overload conditions. Current protection is triggered at typical 7.5A.

#### 4. Stability and load regulation

AME1084 requires a capacitor from  $V_{OUT}$  to GND to provide compensation feedback to the internal gain stage. This is to ensure stability at the output terminal. Typically, a 10µF tantalum or 50µF aluminum electrolytic is sufficient.

Note: It is important that the ESR for this capacitor does not exceed 0.5Ω.

The output capacitor does not have a theoretical upper limit and increasing its value will increase stability.  $C_{OUT} = 100\mu F$  or more is typical for high current regulator design.

For the adjustable version, the best load regulation is accomplished when the top of the resistor divider ( $R1$ ) is connected directly to the output pin of the AME1084. When so connected,  $R_p$  is not multiplied by the divider ratio.

For fixed output versions, the top of  $R1$  is internally connected to the output. The ground pin can be connected to low side of the load to eliminate ground loop errors.

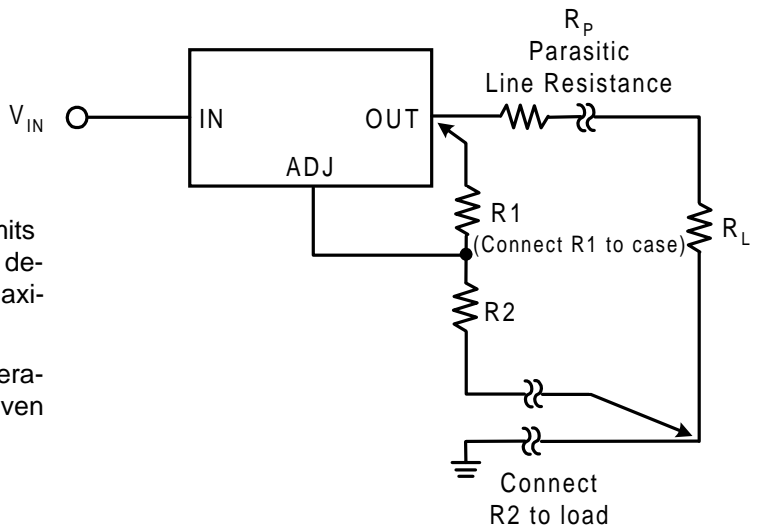

Figure 4



**5. Thermal consideration**

The AME1084 series contain thermal limiting circuitry designed to protect itself for over-temperature conditions. Even for normal load conditions, maximum junction temperature ratings must not be exceeded. As mentioned in the thermal protection section, we need to consider all sources of thermal resistance between junction and ambient. It includes junction-to-case, case-to-heat-sink interface and heat sink thermal resistance itself.

Junction-to-case thermal resistance is specified from the IC junction to the bottom of the case directly below the die. Proper mounting is required to ensure the best possible thermal flow from this area of the package to the heat sink. The case of all devices in this series is electrically connected to the output. Therefore, if the case of the device must be electrically isolated, a thermally conductive spacer is recommended.



■ Advanced Applications

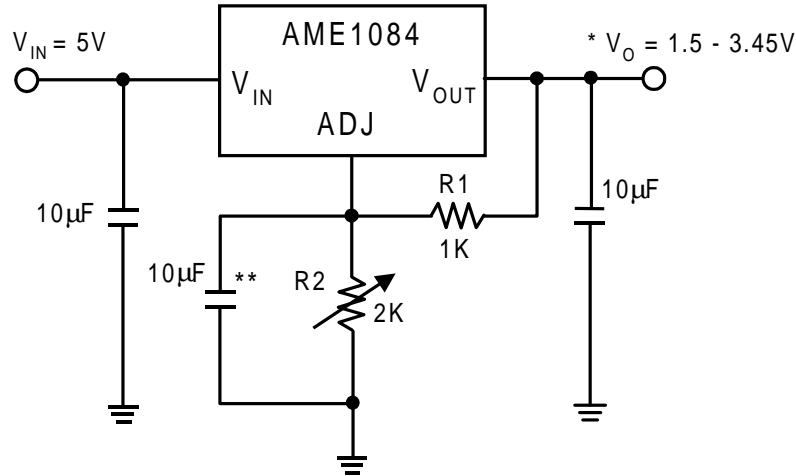

$$* V_o = V_{REF} \left( 1 + \frac{R2}{R1} \right) + I_{ADJ} \times R2$$

\*\* Optional for improved ripple rejection

Figure 5 Adjustable Output Voltage

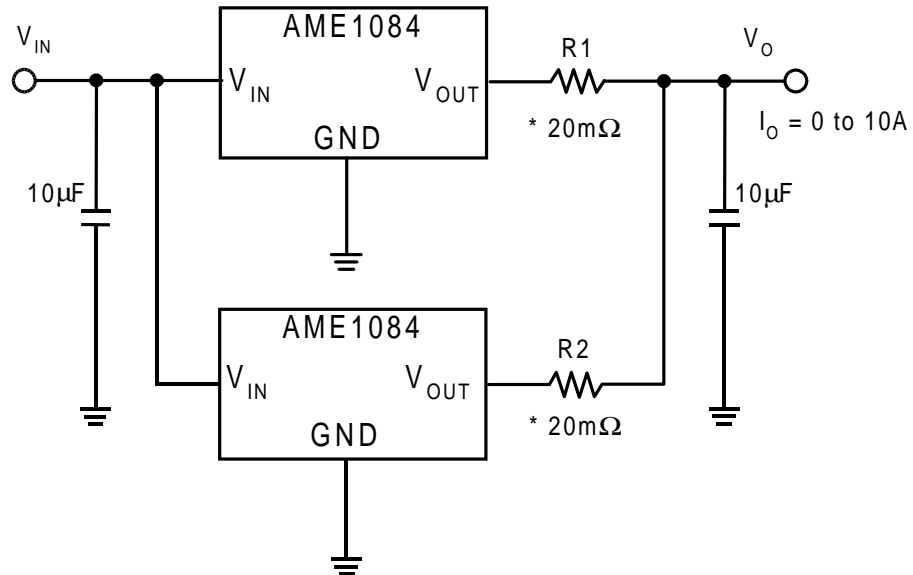

\* 20mW is ballast resistance

The inter - connection of #18 wire could act as ballast resistance

Figure 6 Paralleling Regulators





■ Advanced Applications (Cont.)

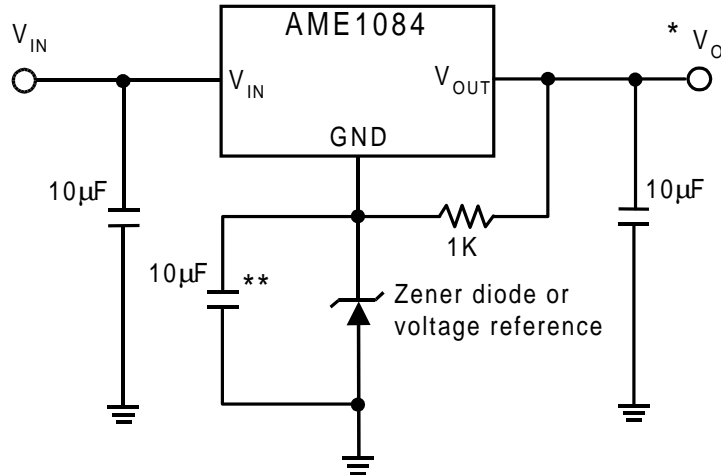

\*  $V_o = V_{REF} + V_z$  ( $V_z$ : breakdown voltage of Zener diode)

\*\* Optional for improved ripple rejection

Figure 7 Regulator with Reference

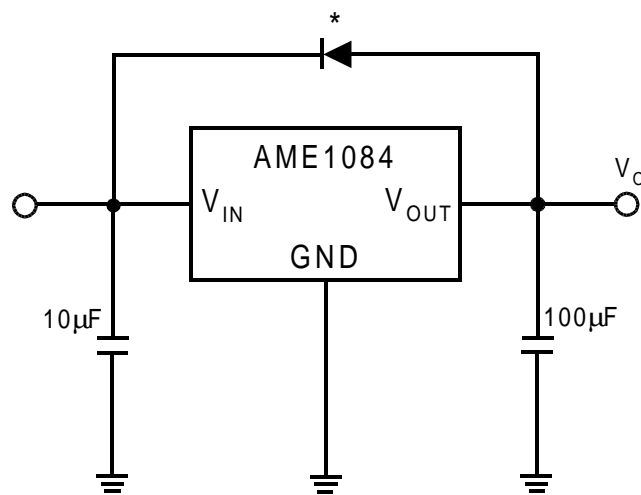
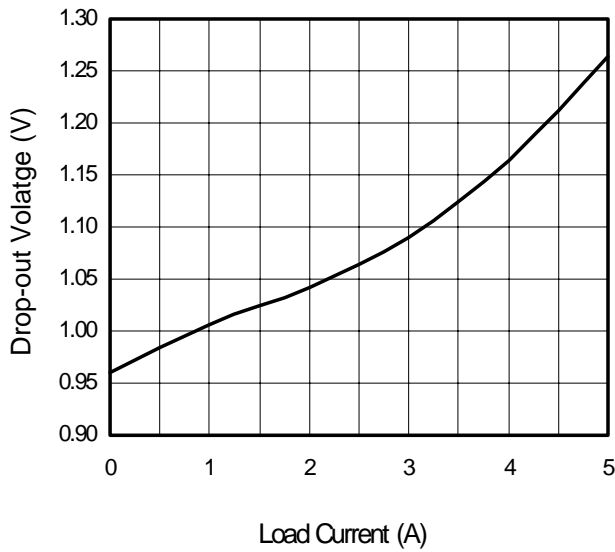

Figure 8 Regulator with Reverse Diode Protection



### ■ Performance Characteristics

Drop-out Voltage vs. Load Current



Minimum Operation Current vs  
Input/Output Differential Voltage

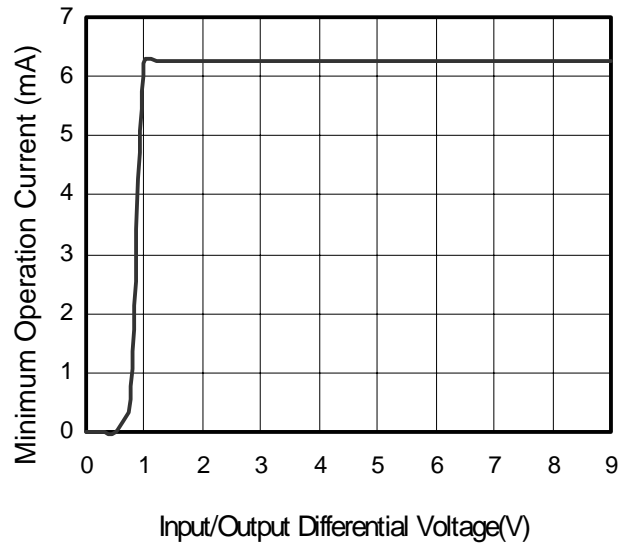

Output Short circuit Current vs  
Input/Output Differential Voltage

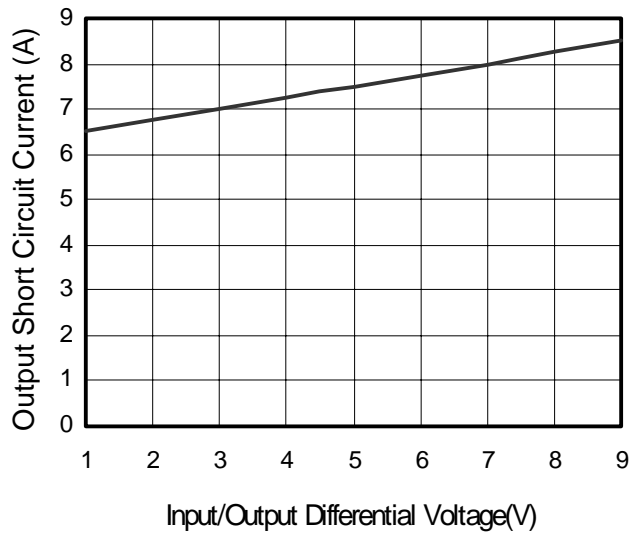



■ External Resistor Divider Table for Customized Voltage

R1(ohm)	100	102	105	107	110	113	115	118	121	124
Vout	$R2(ohm)=(Vout-1.25)*R1/(1.25+50u*R1)$									
1.25	0.000	0.000	0.000	0.000	0.000	0.000	0.000	0.000	0.000	0.000
1.30	3.984	4.063	4.182	4.262	4.381	4.500	4.579	4.698	4.817	4.936
1.35	7.968	8.127	8.365	8.524	8.761	8.999	9.158	9.396	9.633	9.871
1.40	11.95	12.19	12.55	12.79	13.14	13.50	13.74	14.09	14.45	14.81
1.45	15.94	16.25	16.73	17.05	17.52	18.00	18.32	18.79	19.27	19.74
1.50	19.92	20.32	20.91	21.31	21.90	22.50	22.89	23.49	24.08	24.68
1.55	23.90	24.38	25.09	25.57	26.28	27.00	27.47	28.19	28.90	29.61
1.60	27.89	28.44	29.28	29.83	30.67	31.50	32.05	32.88	33.72	34.55
1.65	31.87	32.51	33.46	34.09	35.05	36.00	36.63	37.58	38.53	39.48
1.70	35.86	36.57	37.64	38.36	39.43	40.50	41.21	42.28	43.35	44.42
1.75	39.84	40.63	41.82	42.62	43.81	45.00	45.79	46.98	48.17	49.36
1.80	43.82	44.70	46.01	46.88	48.19	49.50	50.37	51.68	52.98	54.29
1.85	47.81	48.76	50.19	51.14	52.57	54.00	54.95	56.37	57.80	59.23
1.90	51.79	52.82	54.37	55.40	56.95	58.50	59.53	61.07	62.62	64.16
1.95	55.78	56.89	58.55	59.66	61.33	63.00	64.11	65.77	67.43	69.10
2.00	59.76	60.95	62.74	63.93	65.71	67.49	68.68	70.47	72.25	74.03
2.05	63.75	65.01	66.92	68.19	70.09	71.99	73.26	75.17	77.07	78.97
2.10	67.73	69.08	71.10	72.45	74.47	76.49	77.84	79.86	81.88	83.90
2.15	71.71	73.14	75.28	76.71	78.85	80.99	82.42	84.56	86.70	88.84
2.20	75.70	77.21	79.47	80.97	83.23	85.49	87.00	89.26	91.52	93.77
2.25	79.68	81.27	83.65	85.24	87.61	89.99	91.58	93.96	96.33	98.71
2.30	83.67	85.33	87.83	89.50	92.00	94.49	96.16	98.65	101.2	103.6
2.35	87.65	89.40	92.01	93.76	96.38	98.99	100.7	103.4	106.0	108.6
2.40	91.63	93.46	96.20	98.02	100.8	103.5	105.3	108.1	110.8	113.5
2.45	95.62	97.52	100.4	102.3	105.1	108.0	109.9	112.7	115.6	118.5
2.50	99.60	101.6	104.6	106.5	109.5	112.5	114.5	117.4	120.4	123.4
2.55	103.6	105.6	108.7	110.8	113.9	117.0	119.1	122.1	125.2	128.3
2.60	107.6	109.7	112.9	115.1	118.3	121.5	123.6	126.8	130.1	133.3
2.65	111.6	113.8	117.1	119.3	122.7	126.0	128.2	131.5	134.9	138.2
2.70	115.5	117.8	121.3	123.6	127.0	130.5	132.8	136.2	139.7	143.1
2.75	119.5	121.9	125.5	127.9	131.4	135.0	137.4	140.9	144.5	148.1
2.80	123.5	126.0	129.7	132.1	135.8	139.5	141.9	145.6	149.3	153.0
2.85	127.5	130.0	133.8	136.4	140.2	144.0	146.5	150.3	154.1	157.9
2.90	131.5	134.1	138.0	140.6	144.6	148.5	151.1	155.0	159.0	162.9
2.95	135.5	138.2	142.2	144.9	148.9	153.0	155.7	159.7	163.8	167.8
3.00	139.4	142.2	146.4	149.2	153.3	157.5	160.3	164.4	168.6	172.7
3.05	143.4	146.3	150.6	153.4	157.7	162.0	164.8	169.1	173.4	177.7
3.10	147.4	150.3	154.8	157.7	162.1	166.5	169.4	173.8	178.2	182.6



■ External Resistor Divider Table for Customized Voltage

R1(ohm)	100	102	105	107	110	113	115	118	121	124
Vout	$R2(ohm)=(Vout-1.25)*R1/(1.25+50u*R1)$									
3.15	151.4	154.4	158.9	161.9	166.5	171.0	174.0	178.5	183.0	187.5
3.20	155.4	158.5	163.1	166.2	170.8	175.5	178.6	183.2	187.9	192.5
3.25	159.4	162.5	167.3	170.5	175.2	180.0	183.2	187.9	192.7	197.4
3.30	163.3	166.6	171.5	174.7	179.6	184.5	187.7	192.6	197.5	202.4
3.35	167.3	170.7	175.7	179.0	184.0	189.0	192.3	197.3	202.3	207.3
3.40	171.3	174.7	179.8	183.3	188.4	193.5	196.9	202.0	207.1	212.2
3.45	175.3	178.8	184.0	187.5	192.8	198.0	201.5	206.7	211.9	217.2
3.50	179.3	182.9	188.2	191.8	197.1	202.5	206.1	211.4	216.8	222.1
3.55	183.3	186.9	192.4	196.0	201.5	207.0	210.6	216.1	221.6	227.0
3.60	187.3	191.0	196.6	200.3	205.9	211.5	215.2	220.8	226.4	232.0
3.65	191.2	195.0	200.8	204.6	210.3	216.0	219.8	225.5	231.2	236.9
3.70	195.2	199.1	204.9	208.8	214.7	220.5	224.4	230.2	236.0	241.8
3.75	199.2	203.2	209.1	213.1	219.0	225.0	228.9	234.9	240.8	246.8
3.80	203.2	207.2	213.3	217.3	223.4	229.5	233.5	239.6	245.7	251.7
3.85	207.2	211.3	217.5	221.6	227.8	234.0	238.1	244.3	250.5	256.6
3.90	211.2	215.4	221.7	225.9	232.2	238.5	242.7	249.0	255.3	261.6
3.95	215.1	219.4	225.9	230.1	236.6	243.0	247.3	253.7	260.1	266.5
4.00	219.1	223.5	230.0	234.4	240.9	247.5	251.8	258.4	264.9	271.5
4.05	223.1	227.6	234.2	238.7	245.3	252.0	256.4	263.1	269.7	276.4
4.10	227.1	231.6	238.4	242.9	249.7	256.5	261.0	267.8	274.6	281.3
4.15	231.1	235.7	242.6	247.2	254.1	261.0	265.6	272.5	279.4	286.3
4.20	235.1	239.7	246.8	251.4	258.5	265.5	270.2	277.2	284.2	291.2
4.25	239.0	243.8	250.9	255.7	262.8	270.0	274.7	281.9	289.0	296.1
4.30	243.0	247.9	255.1	260.0	267.2	274.5	279.3	286.6	293.8	301.1
4.35	247.0	251.9	259.3	264.2	271.6	279.0	283.9	291.3	298.6	306.0
4.40	251.0	256.0	263.5	268.5	276.0	283.5	288.5	296.0	303.5	310.9
4.45	255.0	260.1	267.7	272.8	280.4	288.0	293.1	300.7	308.3	315.9
4.50	259.0	264.1	271.9	277.0	284.7	292.5	297.6	305.4	313.1	320.8
4.55	262.9	268.2	276.0	281.3	289.1	297.0	302.2	310.1	317.9	325.7
4.60	266.9	272.2	280.2	285.5	293.5	301.5	306.8	314.8	322.7	330.7
4.65	270.9	276.3	284.4	289.8	297.9	306.0	311.4	319.5	327.5	335.6
4.70	274.9	280.4	288.6	294.1	302.3	310.5	315.9	324.2	332.4	340.6
4.75	278.9	284.4	292.8	298.3	306.7	315.0	320.5	328.8	337.2	345.5
4.80	282.9	288.5	297.0	302.6	311.0	319.5	325.1	333.5	342.0	350.4
4.85	286.9	292.6	301.1	306.8	315.4	324.0	329.7	338.2	346.8	355.4
4.90	290.8	296.6	305.3	311.1	319.8	328.5	334.3	342.9	351.6	360.3
4.95	294.8	300.7	309.5	315.4	324.2	333.0	338.8	347.6	356.4	365.2
5.00	298.8	304.8	313.7	319.6	328.6	337.5	343.4	352.3	361.3	370.2



■ Package Dimension

TO-220

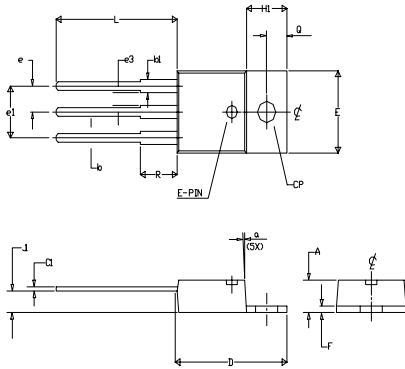

SYMBOLS	MILLIMETERS		INCHES	
	MIN	MAX	MIN	MAX
A	4.06	4.83	0.160	0.190
b	0.63	1.02	0.025	0.040
C1	0.35	0.60	0.0138	0.0236
D	14.22	14.99	0.056	0.590
E	9.66	10.54	0.385	0.415
e	-	2.79	-	0.110
e1	4.83	5.33	0.190	0.210
e3	1.14	1.40	0.045	0.055
f	1.14	1.40	0.045	0.055
H1	5.94	6.55	0.234	0.258
K	2.29	2.92	0.090	0.115
CP	3.71	3.96	0.146	0.156
Q	2.62	2.87	0.103	0.113
L	12.70	14.27	0.500	0.5618
a	3D	7D	3D	7D
b1	1.14	1.52	0.0449	0.06
R	6.17 REF.		0.243 REF.	

Notes :

1. Dimension C1 apply for tin plate finish.
2. For solder dip lead finish dimension C1 should be 0.015"-0.027" (0.38-0.69)

TO-263-3

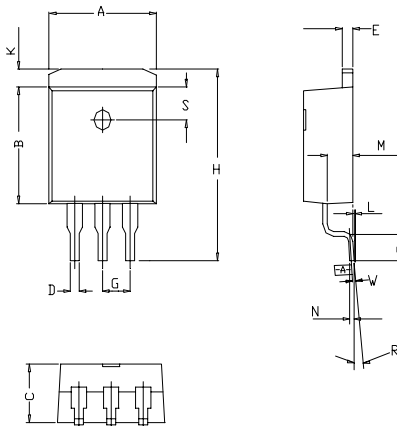

SYMBOLS	MILLIMETERS		INCHES	
	MIN	MAX	MIN	MAX
A	9.65	10.41	0.380	0.410
B	8.28	9.65	0.326	0.380
C	4.06	4.83	0.160	0.190
D	0.51	1.02	0.020	0.040
E	1.14	1.40	0.045	0.055
G	*2.54		*0.100	
H	14.61	15.88	0.575	0.625
K	1.02	1.68	0.040	0.066
L	0.00	0.97	0.000	0.038
M	2.49	2.74	0.098	0.108
N	0.43	0.58	0.017	0.023
P	2.29	2.79	0.090	0.110
R	0°	8°	0°	8°
S	2.41	2.67	0.095	0.105
W	0.254	0.508	0.010	0.020

\* : Typical value

NOTES :

1. CONTROLLING DIMENSION : MILLIMETERS.
2. MAXIMUM LEAD THICKNESS INCLUDES LEAD FINISH THICKNESS  
MINIMUM LEAD THICKNESS IS THE MINIMUM THICKNESS OF BASE MATERIA.



■ Package Dimension

TO-263-2

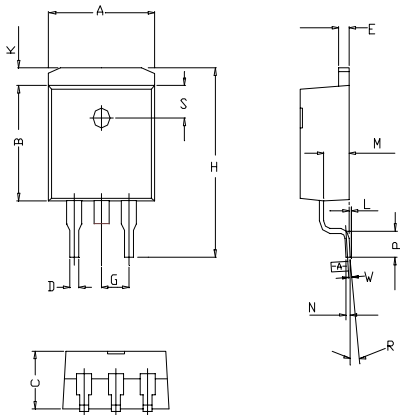

SYMBOLS	MILLIMETERS		INCHES	
	MIN	MAX	MIN	MAX
A	9.65	10.41	0.380	0.410
B	8.28	9.65	0.326	0.380
C	4.06	4.83	0.160	0.190
D	0.51	1.02	0.020	0.040
E	1.14	1.40	0.045	0.055
G	*2.54		*0.100	
H	14.61	15.88	0.575	0.625
K	1.02	1.68	0.040	0.066
L	0.00	0.97	0.000	0.038
M	2.49	2.74	0.098	0.108
N	0.43	0.58	0.017	0.023
P	2.29	2.79	0.090	0.110
R	0°	8°	0°	8°
S	2.41	2.67	0.095	0.105
W	0.254	0.508	0.010	0.020

\* : Typical value

NOTES :

- 1. CONTROLLING DIMENSION : MILLIMETERS.
- 2. MAXIMUM LEAD THICKNESS INCLUDES LEAD FINISH THICKNESS
- MINIMUM LEAD THICKNESS IS THE MINIMUM THICKNESS OF BASE MATERIA.



■ Package Dimension

TO-252 (DPAK)

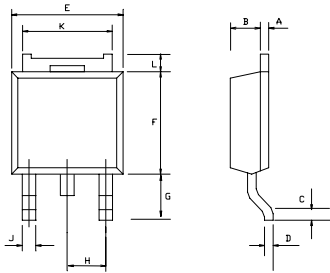

SYMBOLS	MILLIMETERS		INCHES	
	MIN	MAX	MIN	MAX
A	0.45	0.58	0.0177	0.023
B	1.60	1.95	0.06	0.0768
C	0.51	-	0.02	-
D	0.45	0.60	0.0177	0.0236
E	6.40	6.80	0.252	0.2677
F	5.40	5.80	0.2126	0.2283
G	2.20	2.85	0.0866	0.1122
H	-	* 2.30	-	* 0.0906
I	-	0.90	-	0.0354
J	-	0.97	-	0.038
K	5.20	5.50	0.20	0.22
L	0.89	2.03	0.035	0.08

\* : Typical value

NOTES :

1. CONTROLLING DIMENSION : MILLIMETERS.
2. MAXIMUM LEAD THICKNESS INCLUDES LEAD FINISH THICKNESS  
MINIMUM LEAD THICKNESS IS THE MINIMUM THICKNESS OF BASE MATERIAL.

TO-252 (DPAK)

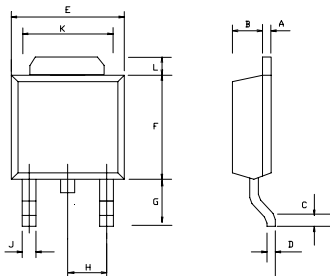

SYMBOLS	MILLIMETERS		INCHES	
	MIN	MAX	MIN	MAX
A	0.45	0.58	0.0177	0.023
B	1.60	1.95	0.06	0.0768
C	0.51	-	0.02	-
D	0.45	0.60	0.0177	0.0236
E	6.40	6.80	0.252	0.2677
F	5.40	5.80	0.2126	0.2283
G	2.20	2.85	0.0866	0.1122
H	-	* 2.30	-	* 0.0906
I	-	0.90	-	0.0354
J	-	0.97	-	0.038
K	5.20	5.50	0.20	0.22
L	0.89	2.03	0.035	0.08

\* : Typical value

NOTES :

1. CONTROLLING DIMENSION : MILLIMETERS.
2. MAXIMUM LEAD THICKNESS INCLUDES LEAD FINISH THICKNESS  
MINIMUM LEAD THICKNESS IS THE MINIMUM THICKNESS OF BASE MATERIAL.



**www.analogmicro.com**  
**E-Mail: info@analogmicro.com**

**Life Support Policy:**

These products of Analog Microelectronics, Inc. are not authorized for use as critical components in life-support devices or systems, without the express written approval of the president of Analog Microelectronics, Inc.

Analog Microelectronics, Inc. reserves the right to make changes in the circuitry and specifications of its devices and advises its customers to obtain the latest version of relevant information.

© Analog Microelectronics, Inc. , July 2001

Document: 1012-doc-B-0704

**Corporate Headquarters**  
**Analog Microelectronics, Inc.**

3100 De La Cruz Blvd. Suite 201  
Santa Clara, CA. 95054-2046  
Tel : (408) 988-2388  
Fax: (408) 988-2489

**Asia Pacific Headquarters**  
**AME, Inc.**

2F, 187 ,Kang-Chien Rd, Nei-Hu District  
Taipei 114, Taiwan, R.O.C.  
Tel : 886 2 2627-8687  
Fax: 886 2 2659-2989