



AME5130

Micropower Step-Up DC/DC Converter

General Description

The AME5130 is a fixed off-time step-up DC/DC converter in a small 5-lead SOT-25 package. The AME5130 is ideal for LCD panels requiring low current and high efficiency as well as LED applications for cellular phone back-lighting, PDAS, and other hand-held devices. The low 400ns off-time allows the use of tiny external components.

AME5130 can drive up to 8 white LEDs from a single Li-Ion battery DC 2V to 5.5V; can be turned on by putting more than 1V at pin 4 (RUN). To control LED brightness, the LED current can be pulsed by applying a PWM (pulse width modulated) signal with a frequency range of 100Hz to 50KHz to the RUN pin.

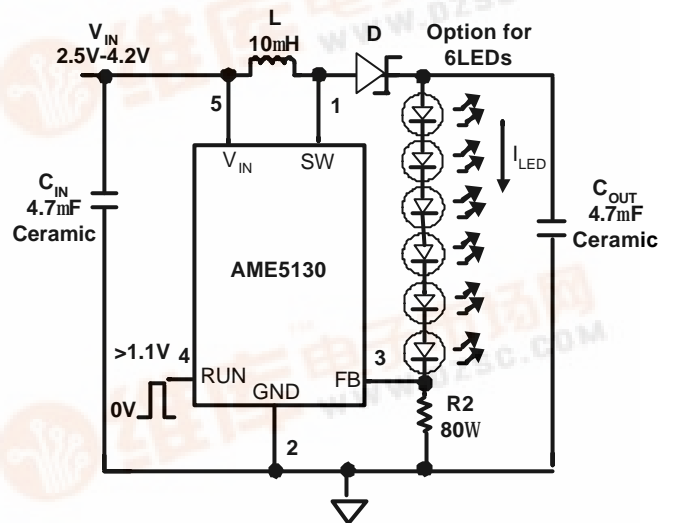
Features

- 0.7Ω internal switch
- Uses small surface mount components
- Adjustable output voltage up to 20V
- 2V to 5.5V input range
- Input undervoltage lockout
- 0.01μA shutdown current
- Small 5-Lead SOT-25 package

Applications

- White LED Back-Lighting
- Hand-held Devices
- Digital Cameras
- Portable Applications
- LCD Bias Power

Typical Application



$$* I_{LED} = V_{FB} / R2$$

Figure 1 : Six White LEDs Application in Li-Ion Battery

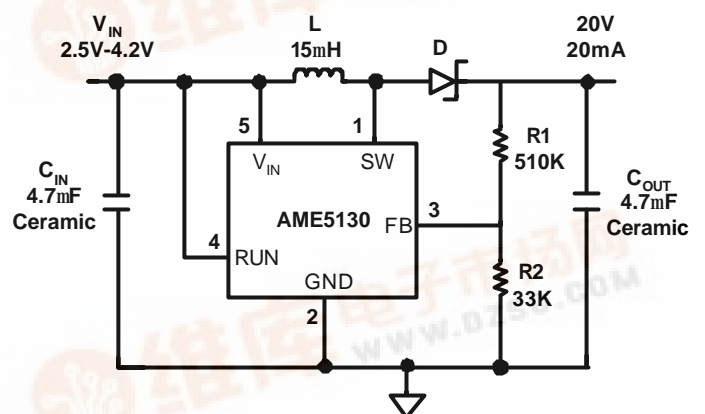


Figure 2 : Typical 20V Application

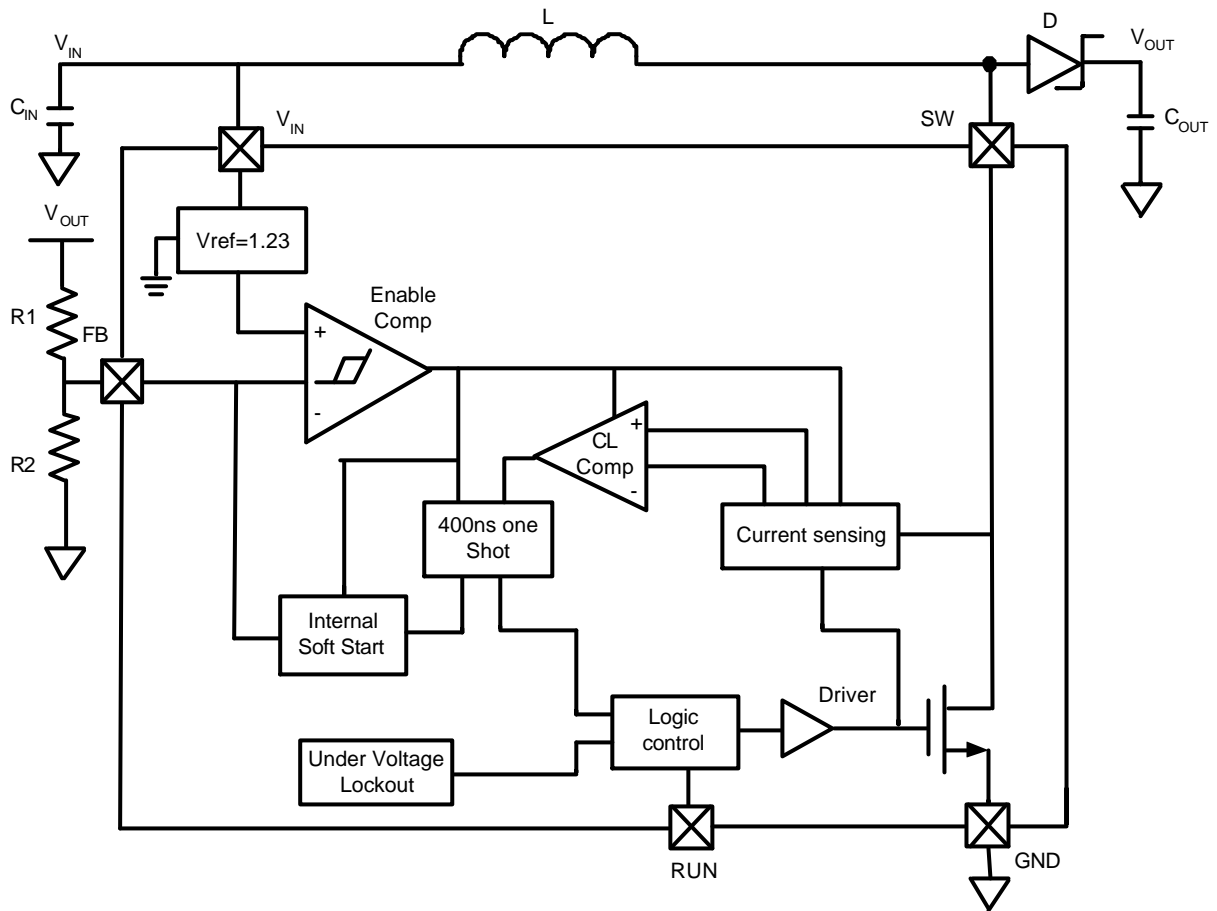
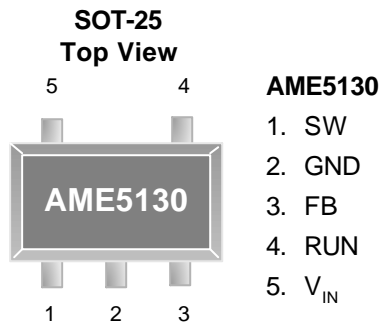
■ Function Block Diagram


Figure 3 : AME5130 Block Diagram



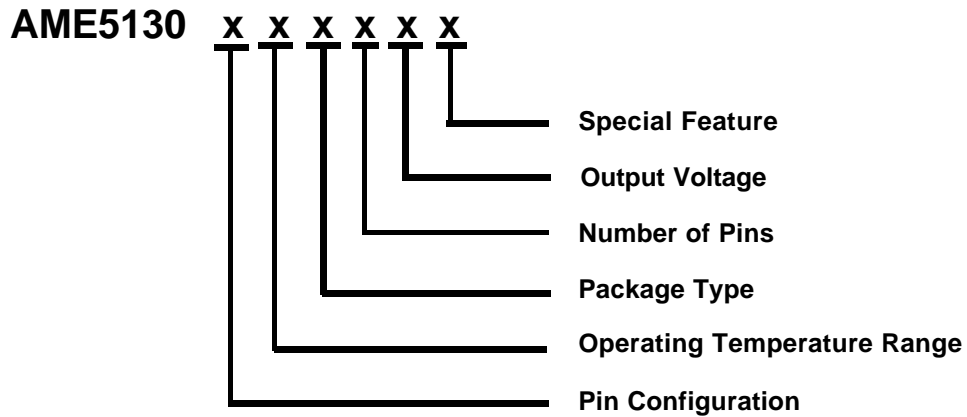
■ Pin Configuration



* Epoxy: Conductive

■ Pin Description

Pin #	Pin Name	Pin Description
1	SW	Power Switch input. This is the drain of the internal NMOS power switch. Minimize the metal trace area connected to this pin to minimize EMI.
2	GND	Ground. Tie directly to ground plane.
3	FB	Output voltage feedback input. Set the output voltage by selecting values for R1 and R2 using: $R1 = R2 \left(\frac{V_{out}}{1.23V} - 1 \right)$ Connect the ground of the feedback network to an AGND(Analog Ground) plane which should be tied directly to the GND pin.
4	RUN	Shutdown control input, active low. The shutdown pin is an active low control. Tie this pin above 1V to enable the device. Tie this pin below 0.4V to turn off the device.
5	V_{IN}	Analog and Power input. Input Supply Pin. Bypass this pin with a capacitor as close to the device as possible.

■ Ordering Information


Pin Configuration	Operating Temperature Range	Package Type	Number of Pins	Output Voltage	Special Feature
A 1. SW 2. GND 3. FB 4. RUN 5. V _{IN}	E: -40°C to 85°C	E: SOT-2X	V: 5	ADJ: Adjustable	Z: Lead free

■ Ordering Information

Part Number	Marking*	Output Voltage	Package	Operating Temp. Range
AME5130AEEVADJ	BCLww	ADJ	SOT-25	-40°C to +85°C
AME5130AEEVADJZ	BCLww	ADJ	SOT-25	-40°C to +85°C

Note: ww represents the date code and pls refer to Date Code Rule before Package Dimension.

* A line on top of the first letter represents lead free plating such as BCL.

Please consult AME sales office or authorized Rep./Distributor for the availability of package type.

■ Absolute Maximum Ratings

Parameter	Symbol	Maximum	Unit
Input Supply Voltage	V_{IN}	6	V
RUN, V_{FB} Voltages	V_{RUN}, V_{FB}	V_{IN}	V
SW Voltage	V_{SW}	$V_{OUT}+0.3$	V
N-Channel Switch Sink Current	I_{SW}	800	mA
ESD Classification		B	

Caution: Stress above the listed absolute maximum rating may cause permanent damage to the device

■ Recommended Operating Conditions

Parameter	Rating	Unit
Ambient Temperature Range	-40 to +85	°C
Junction Temperature	-40 to +125	°C

■ Thermal Information

Parameter	Package	Die Attached	Symbol	Maximum	Unit
Thermal Resistance* (Junction to Case)	SOT-25	Conductive	θ_{JC}	81	°C / W
Thermal Resistance (Junction to Ambient)			θ_{JA}	260	
Internal Power Dissipation ($\Delta T = 100^\circ\text{C}$)			P_D	400	mW
Maximum Junction Temperature				150	°C
Lead Temperature (Soldering 10sec)				300	°C

* The case point of θ_{JC} is on the center of Molding Compound.

■ Electrical Specifications
 $V_{IN}=2.2V$, RUN = V_{IN} , $T_A = 25^{\circ}C$ Unless otherwise noted.

Parameter	Symbol	Test Condition	Min	Typ	Max	Units
Device Disabled	I_Q	FB = 1.3V		64	80	μA
Device Enabled		FB = 1.15V		69	90	
Shutdown		RUN = 0V		0.01	2	
Feedback Trip Point	V_{FB}		1.199	1.23	1.261	V
Switch Current Limit	I_{CL}	$I_{OUT}=20mA$, $V_{OUT}=20V$	490	550	610	mA
FB Pin Bias Current	I_B	FB = 1.23V		0.2	0.7	μA
Input Voltage Range	V_{IN}		2		5.5	V
Switch $R_{DS(ON)}$	$R_{DS(ON)}$			0.7	1.6	Ω
Switch Off Time	T_{OFF}			400		ns
RUN Pin Current	I_{SD}	RUN = V_{IN} , $T_J = 25^{\circ}C$		0		nA
		RUN = V_{IN} , $T_J = 125^{\circ}C$		15		nA
		RUN = GND		0		nA
Switch Leakage Current	I_L	$V_{SW} = 20V$		0.05	5.0	μA
Input Undervoltage Lockout	UVP	ON/OFF Threshold		1.6		V
Feedback Hysteresis	V_{FB} Hysteresis			8		mV
RUN L_{OW} (Shutdown)	RUN Threshold				0.4	V
RUN High (Enable the device)			1			V



■ Electrical Specifications

The AME5130 features a constant off-time control scheme. Operation can be best understood by referring to Figure 3. When the voltage at the FB pin is less than 0.9V, the Enable Comp in Figure 3 enables the device and the NMOS switch is turned on pulling the SW pin to ground. When the NMOS switch is on, current is supplied by the output capacitor C_{OUT} . Once the current in the inductor reaches the peak current limit, the 400ns One Shot turns off the NMOS switch. The SW voltage will then rise to the output voltage plus a diode drop and the inductor current will begin to decrease as shown in Figure 3. During this time the energy stored in the inductor is transferred to C_{OUT} and the load. After the 400ns off-time the NMOS switch is turned on and energy is stored in the inductor again. This energy transfer from the inductor to the output causes a stepping effect in the output ripple.

This cycle is continued until the voltage at FB reaches 1.23V. When FB reaches this voltage, the enable comparator then disables the device turning off the NMOS switch and reducing the Iq of the device to 64 μ A. The load current is then supplied solely by C_{OUT} indicated by the gradually decreasing slope at the output. When the FB pin drops slightly below 1.23V, the enable comparator enables the device and begins the cycle described previously. The RUN pin can be used to turn off the AME5130 and reduce the Iq to 0.01 μ A. In shutdown mode the output voltage will be a diode drop lower than the input voltage.

■ Application Information

INDUCTOR SELECTION

The appropriate inductor for a given application is calculated using the following equation:

$$L = \left(\frac{V_{OUT} - V_{IN(min)} + V_D}{I_{CL}} \right) T_{OFF}$$

Where V_D is the schottky diode voltage, I_{CL} is the switch current limit found in the Typical Performance Characteristics section, and T_{OFF} is the switch off time. When using this equation be sure to use in minimum input voltage for the application, such as for battery powered applications.

Choosing inductors with low ESR decrease power loss and increase efficiency.

Care should be taken when choosing an inductor. For applications that require an input voltage that approaches the output voltage, such as when converting a Li-ion battery voltage to 5V, the 400ns off time may not be enough time to discharge the energy in the inductor and transfer the energy to the output capacitor and load. This can cause a ramping effect in the inductor current waveform and an increased ripple on the output voltage. Using a smaller inductor will cause the I_{PK} to increase and will increase the output voltage ripple further. This can be solved by adding a 4.7pF capacitor across the R1 feedback resistor (Figure 3) and slightly increasing the output capacitor. A smaller inductor can then be used to ensure proper discharge in the 400ns off time.

DIODE SELECTION

To maintain high efficiency, the average current rating of the schottky diode should be larger than the peak inductor current, I_{PK} . Schottky diodes with a low forward drop and fast switching speeds are ideal for increasing efficiency in portable applications. Choose a reverse breakdown of the schottky diode larger than the output voltage.

CAPACITOR SELECTION

Choose low ESR capacitors for the output to minimize output voltage ripple. Multilayer ceramic capacitors are the best choice. For most applications, a 1 μ F ceramic capacitor is sufficient. For some applications a reduction in output voltage ripple can be achieved by increasing the output capacitor. Local bypassing for the input is needed on the AME5130. Multilayer ceramic capacitors are a good choice for this as well. A 4.7 μ F capacitor is sufficient for most applications. For additional bypassing, a 100nF ceramic capacitor can be used to shunt high frequency ripple on the input.

LAYOUT CONSIDERATIONS

The input bypass capacitor C_{IN} , as shown in Figure 3, must be placed close to the IC. This will reduce copper trace resistance which effects input voltage ripple of the IC. For additional input voltage filtering, a 100nF bypass capacitor can be placed in parallel with C_{IN} to shunt any high frequency noise to ground. The output capacitor, C_{OUT} , should also be placed close to the IC. Any copper trace connections for the C_{OUT} capacitor can increase the series resistance, which directly effects output voltage ripple. The feedback network, resistors R1 and R2, should be kept close to the FB pin to minimize copper trace connections that can inject noise into the system. The ground connection for the feedback resistor network should connect directly to an analog ground plane. The analog ground plane should tie directly to the GND pin. If no analog ground plane is available, the ground connection for the feedback network should tie directly to the GND pin. Trace connections made to the inductor and schottky diode should be minimized to reduce power dissipation and increase overall efficiency.

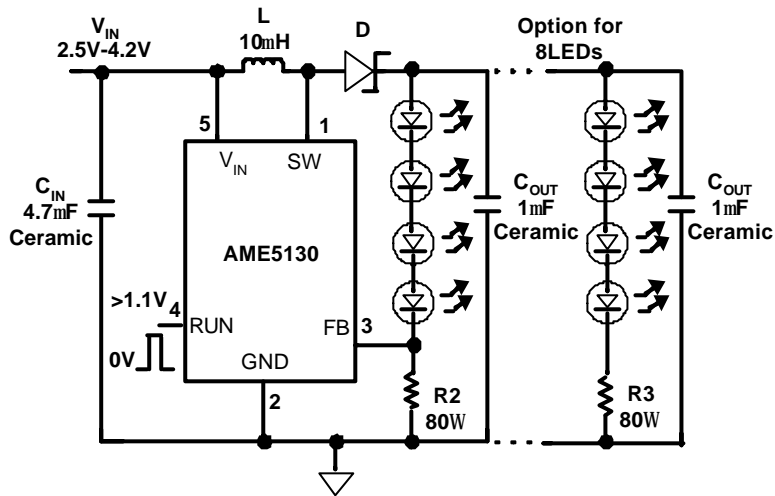
■ Application Information


Figure4: Eight White LEDs Application in Li-Ion Battery

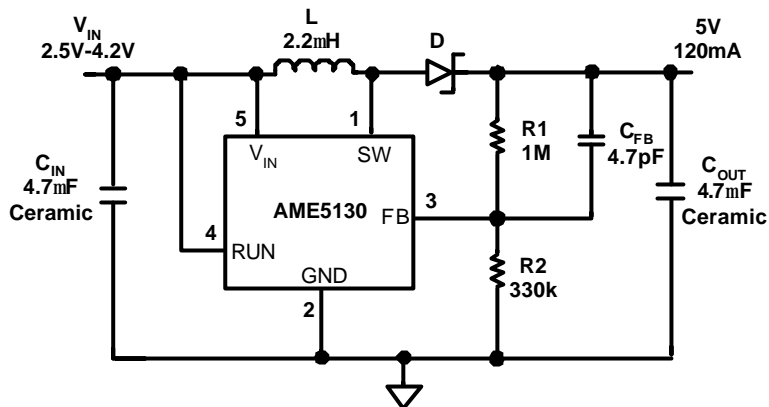


Figure5: Li-Ion 5V Application

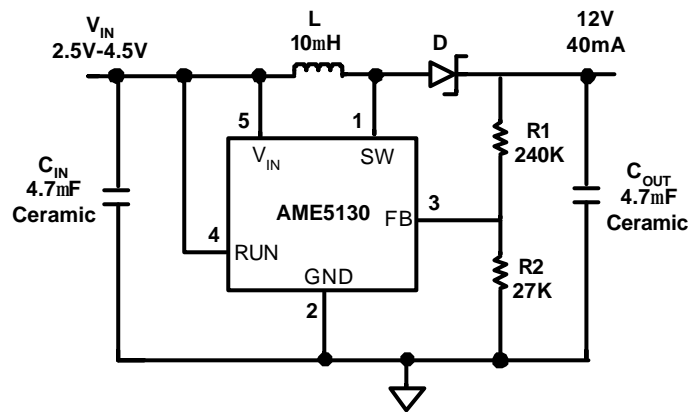
■ Application Information


Figure6: Li-Ion 12V Application

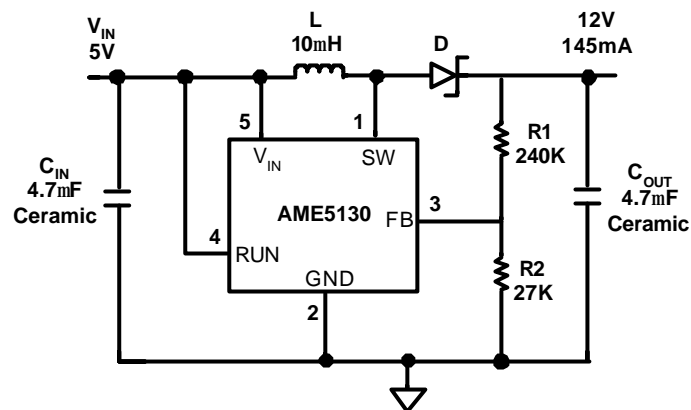
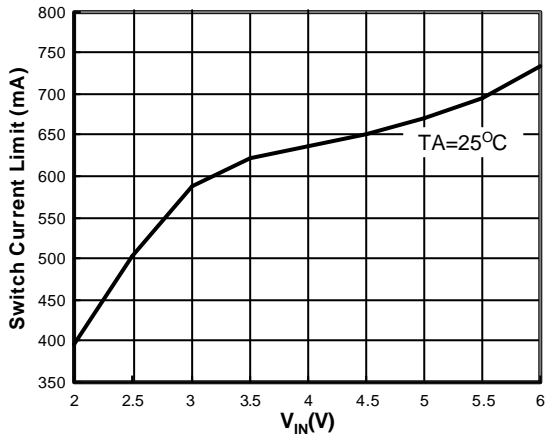


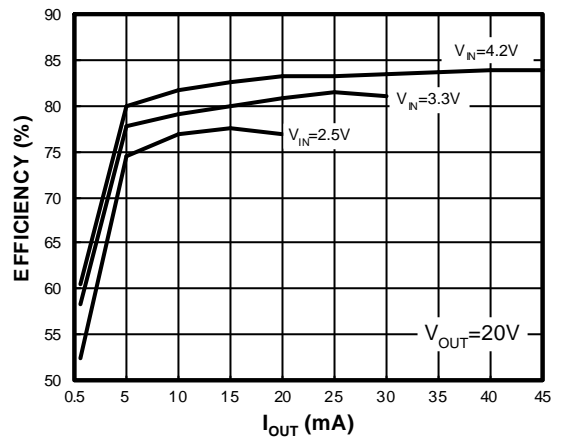
Figure7: 5V to 12V Application



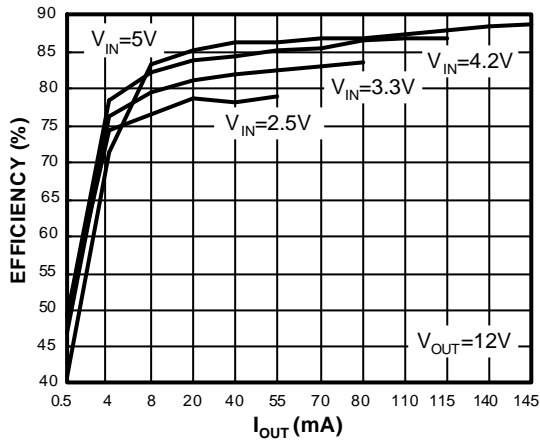
Switch Current Limit vs. V_{IN}



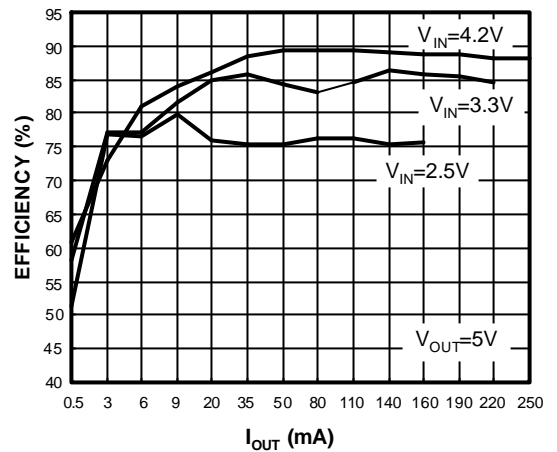
Efficiency vs. Load Current



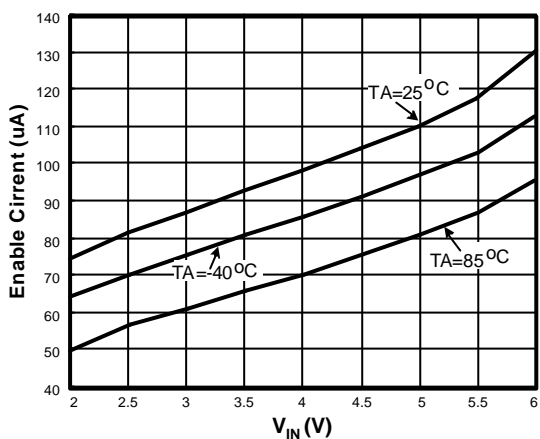
Efficiency vs. Load Current



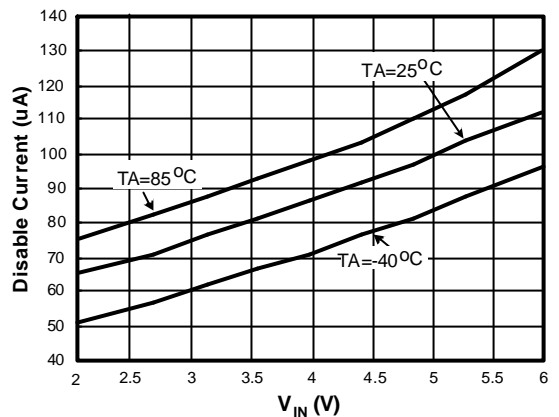
Efficiency vs. Load Current

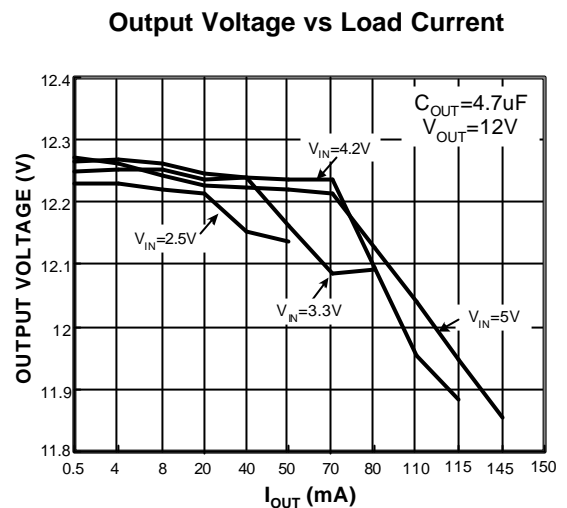
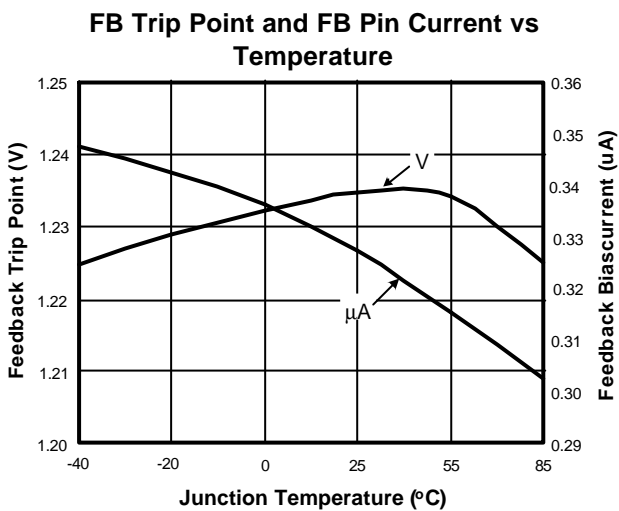
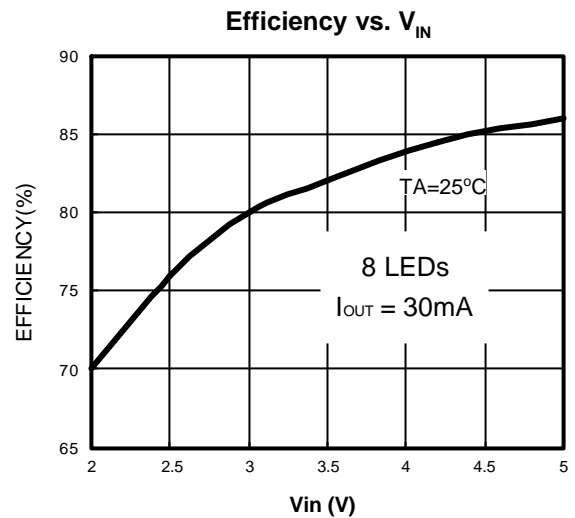
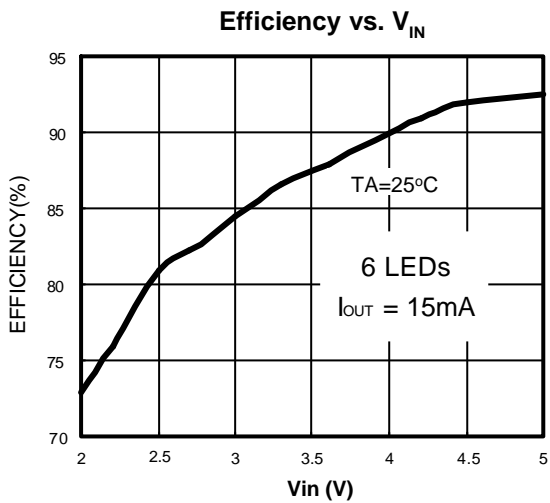
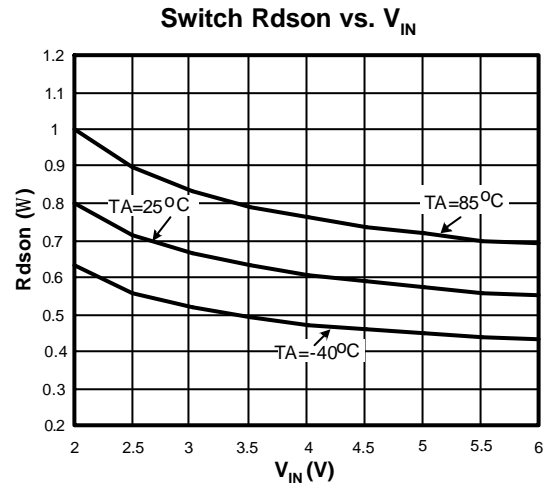
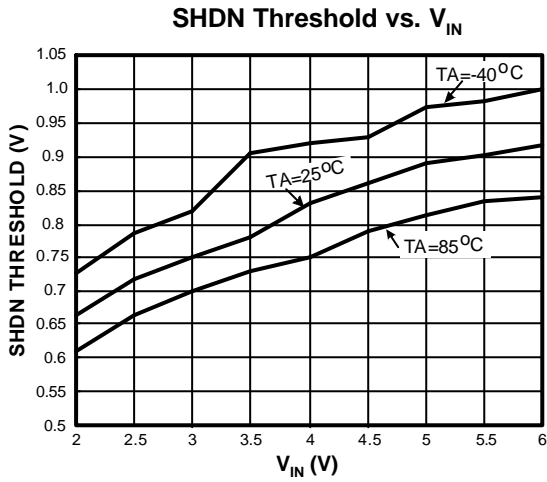


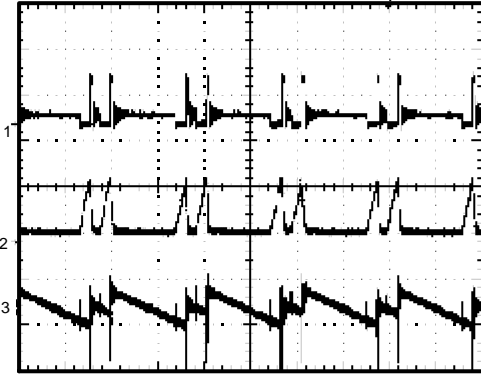
Enable Current vs. V_{IN} (Part Switching)



Disable Current vs. V_{IN} (Part Not Switching)





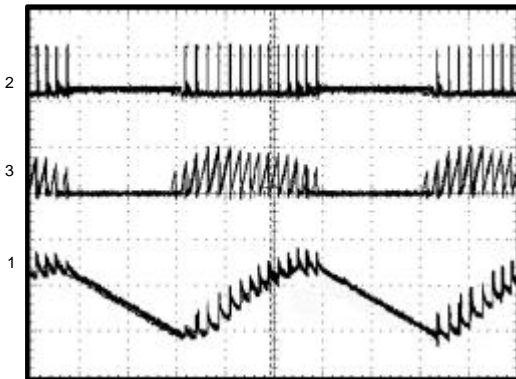
Typical Switching Waveform

 $V_{OUT} = 19.4V, V_{IN} = 4.2V ; 6 \text{ LEDs}$
 $I_{OUT} = 15mA$

- 1) V_{SW} , 20V / div, DC
- 2) Inductor current, 500mA / div, DC
- 3) V_{OUT} , 100mV / div, AC

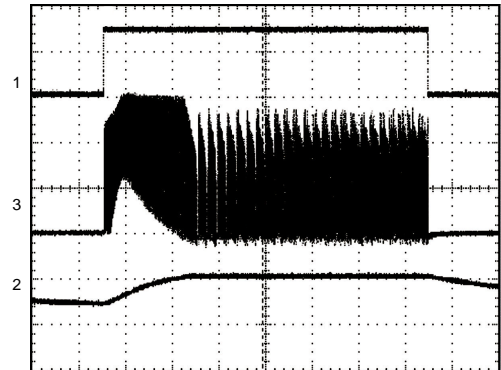
Typical Switching Waveform

 $V_{OUT} = 13.25V, V_{IN} = 4.2V ; 8 \text{ LEDs}$
 $I_{OUT} = 30mA$

- 1) V_{SW} , 20V / div, DC
- 2) Inductor current, 500mA / div, DC
- 3) V_{OUT} , 100mV / div, AC

Start-Up/Shutdown

 $V_{OUT} = 20V, V_{IN} = 2.5V$

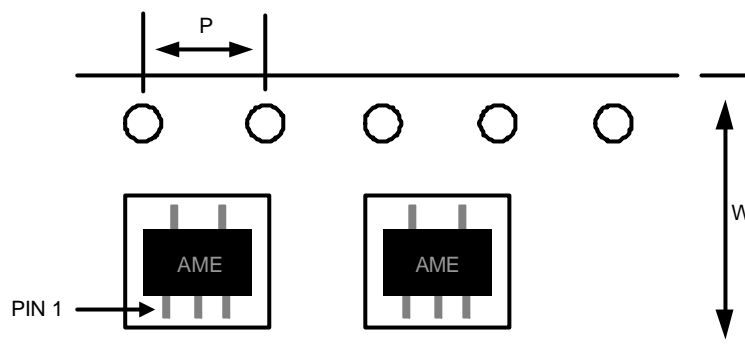
- 1) V_{out} , 100mV/div, AC
 - 2) V_{sw} , 20V/div, DC
 - 3) Inductor Current 500mA/div, DC
- $T=20\mu s/div$

Start-Up/Shutdown

 $V_{OUT} = 20V, V_{IN} = 2.5V$

- 1) RUN, 1V/div, DC
 - 2) V_{OUT} , 20V/div, DC
 - 3) I_L , 200mA/div, DC
- $T=400\mu s/div$
 $R_L=1.3k\Omega$

■ Date Code Rule

Marking			Date Code		Year
A	A	A	W	W	xxx0
A	A	A	W	<u>W</u>	xxx1
A	A	A	<u>W</u>	W	xxx2
A	A	A	<u>W</u>	<u>W</u>	xxx3
A	A	<u>A</u>	W	W	xxx4
A	A	<u>A</u>	W	<u>W</u>	xxx5
A	A	<u>A</u>	<u>W</u>	W	xxx6
A	A	<u>A</u>	<u>W</u>	<u>W</u>	xxx7
A	<u>A</u>	A	W	W	xxx8
A	<u>A</u>	A	W	<u>W</u>	xxx9

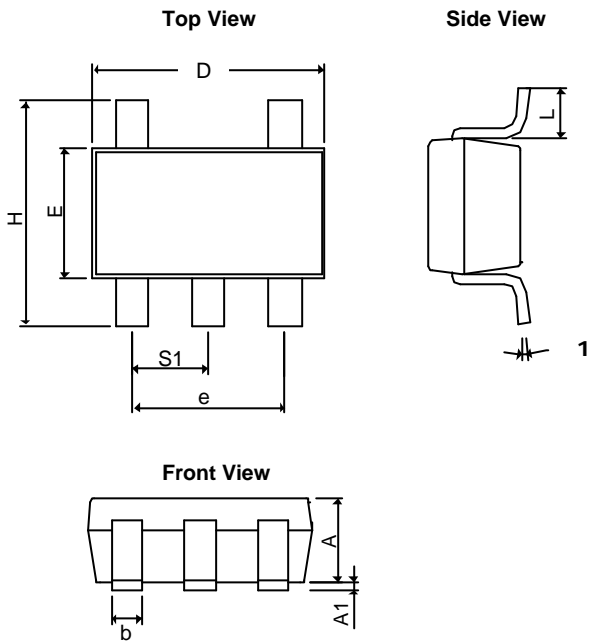
■ Tape and Reel Dimension
SOT-25

Carrier Tape, Number of Components Per Reel and Reel Size

Package	Carrier Width (W)	Pitch (P)	Part Per Full Reel	Reel Size
SOT-25	8.0±0.1 mm	4.0±0.1 mm	3000pcs	180±1 mm



■ Package Dimension

SOT-25



SYMBOLS	MILLIMETERS		INCHES	
	MIN	MAX	MIN	MAX
A	1.20REF		0.0472REF	
A ₁	0.00	0.15	0.0000	0.0059
b	0.30	0.55	0.0118	0.0217
D	2.70	3.10	0.1063	0.1220
E	1.40	1.80	0.0551	0.0709
e	1.90 BSC		0.07480 BSC	
H	2.60	3.00	0.10236	0.11811
L	0.37BSC		0.0146BSC	
q1	0°	10°	0°	10°
S ₁	0.95BSC		0.0374BSC	



www.ame.com.tw

E-Mail: sales@ame.com.tw

Life Support Policy:

These products of AME, Inc. are not authorized for use as critical components in life-support devices or systems, without the express written approval of the president of AME, Inc.

AME, Inc. reserves the right to make changes in the circuitry and specifications of its devices and advises its customers to obtain the latest version of relevant information.

© AME, Inc. , October 2005

Document: 1015-DS5130-C

**Corporate Headquarter
AME, Inc.**

2F, 302 Rui-Guang Road, Nei-Hu District
Taipei 114, Taiwan.
Tel: 886 2 2627-8687
Fax: 886 2 2659-2989

**U.S.A. (Subsidiary)
Analog Microelectronics, Inc.**

3100 De La Cruz Blvd., Suite 201
Santa Clara, CA. 95054-2046
Tel : (408) 988-2388
Fax: (408) 988-2489