

AN1358 (AN6562), AN1358S (AN6562S)

Dual Operational Amplifiers

Overview

The AN1358 (AN6562) and AN1358S (AN6562S) are dual operational amplifiers with two phase compensation circuits built-in, have a wide range of operating supply voltage, and can operate on a single power supply.

They have electrical characteristics equivalent to those of the conventional operational amplifiers, and are low-powered and suitable for application to various circuits. Note) The type numbers in () are old ones.

Features

- Built-in phase compensation circuits
- Wide range of input voltage: 0V to $V_{CC}-1.5V$
- Wide range of operating supply voltage:
Single power supply: 3 to 30V
Dual power supply: ± 1.5 to $\pm 15V$

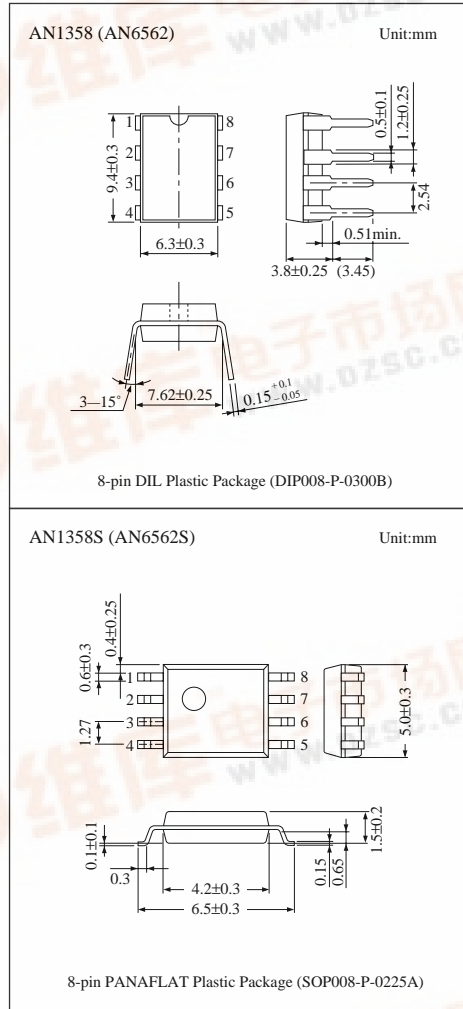

Block Diagram

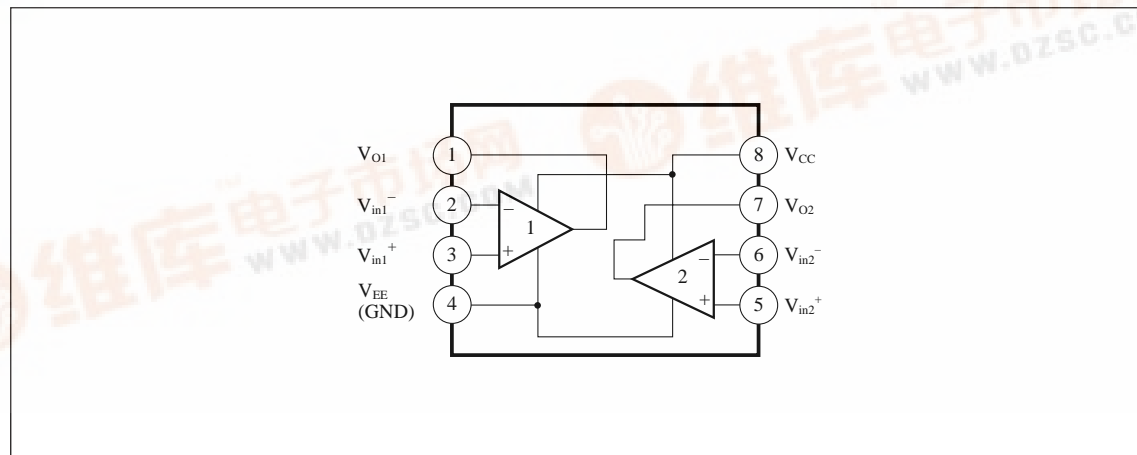

■ Absolute Maximum Ratings (Ta=25°C)

Parameter	Symbol	Rating	Unit
Supply voltage	V _{CC}	32	V
Differential input voltage	V _{ID}	32	V
Common-mode input voltage	V _{ICM}	-0.3 to +32	V
Output voltage	V _O	24	V
Power dissipation	AN1358 (AN6562)	P _D	mW
	AN1358 (AN6562S)		
			360
Operating ambient temperature	T _{opr}	-20 to +75	°C
Storage temperature	AN1358 (AN6562)	T _{stg}	°C
	AN1358S (AN6562S)		
			-55 to +125

■ Recommended Operating Range (Ta=25°C)

Parameter	Symbol	Range
Operating supply voltage range	V _{CC}	Single power supply 3V to 30V
		Dual power supply ±1.5V to ±15V

■ Electrical Characteristics (V_{CC}=5V, Ta=25°C)

Parameter	Symbol	Condition	min	typ	max	Unit
Input offset voltage	V _{I (offset)}	R _S =50Ω	—	2	7	mV
Input bias current	I _{bias}		—	—	250	nA
Input offset current	I _{IO}		—	—	50	nA
Common-mode input voltage width	V _{CM}		0	—	V _{CC} -1.5	V
Supply current	I _{CC}	R _L =∞	—	0.6	1.2	mA
Voltage gain	G _V	R _L ≥2kΩ	—	100	—	dB
Maximum output voltage	V _{O (max.)}	R _L ≥2kΩ	V _{CC} -1.5	—	—	V
Common-mode rejection ratio	CMR		65	85	—	dB
Supply voltage rejection ratio	SVR		65	100	—	dB
Channel separation	CS	f=1 to 20kHz	—	120	—	dB
Output source current	I _{O (source)}	V _{in} ⁺ =1V, V _{in} ⁻ =0V	20	40	—	mA
Output sink current	I _{SINK}	V _{in} ⁺ =0V, V _{in} ⁻ =1V	10	20	—	mA

■ Application Circuit

Non-inverting Amplifier

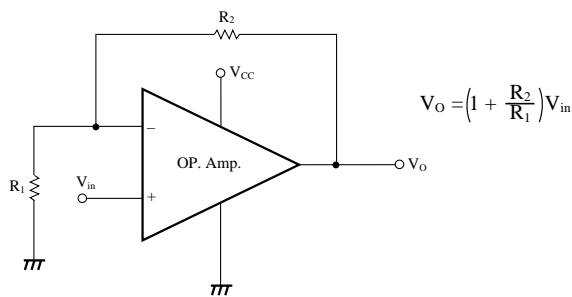

■ Pin Descriptions

Pin No.	Pin name
1	Ch.1 output pin
2	Ch.1 inverting input pin
3	Ch.1 non-inverting input pin
4	Negative supply voltage (GND)
5	Ch.2 non-inverting input pin
6	Ch.2 inverting input pin
7	Ch.2 output pin
8	Positive supply voltage

■ Characteristics Curve

