

ICs for VCR

Panasonic

AN3316K

Recording/Playback Amplifier IC for VCR Hi-Fi Audio

Overview

The AN3316K is an IC developed as a recording/playback amplifier for VCR Hi-Fi audio. In combination with the AN3970 and AN3976, it can configure the system.

Features

- Operating supply voltage : 5V(typ.).
- Adjustment-free recording current by built-in Rec AGC.
- 2-channel output through playback amplifier.

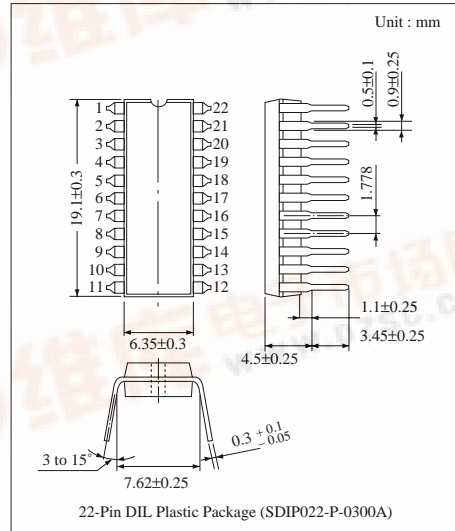

Block Diagram

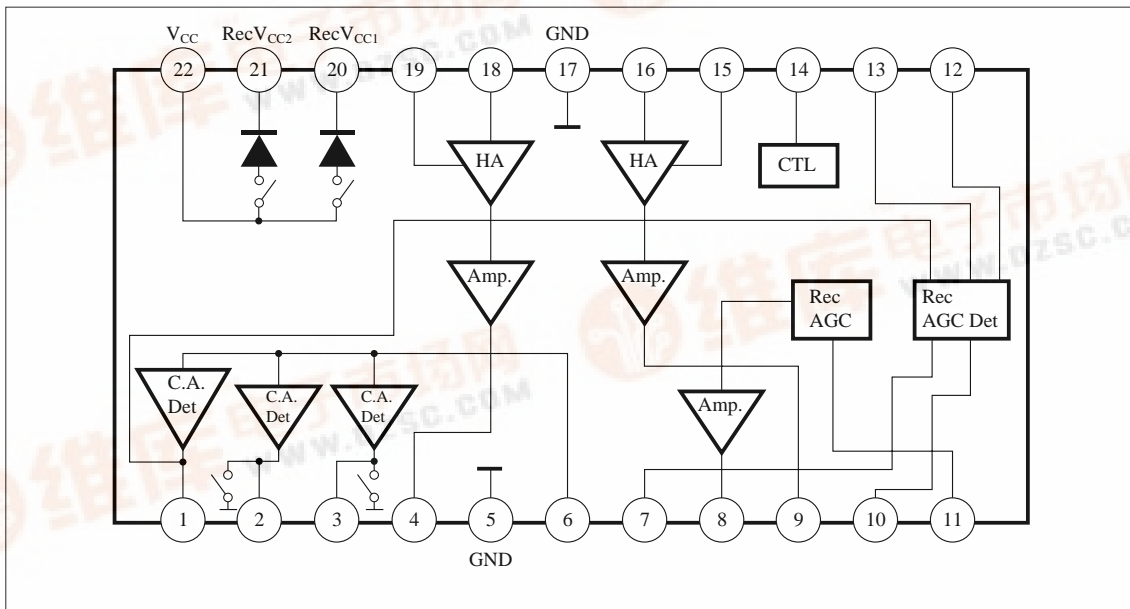

■ Absolute Maximum Ratings (Ta=25°C)

Parameter	Symbol	Rating	Unit
Supply voltage	V _{CC}	6	V
Power dissipation	P _D	600	mW
Operating ambient temperature	T _{opr}	-20 to + 70	°C
Storage temperature	T _{stg}	-55 to + 150	°C

■ Recommended Operating Range (Ta=25°C)

Parameter	Symbol	Range
Operating supply voltage range	V _{CC}	4.5V to 5.5V

■ Electrical Characteristics (Ta=25°C)

Parameter	Symbol	Condition	min	typ	max	Unit
Rec circuit current	I _{REC}	Rec Mode, V _{CC} =5V	—	—	85	mA
Rec AGC level	I _{AGC}	Rec Mode, V _{CC} =5V	22.7	—	32.1	mA _{PP}
Rec AGC control characteristic	ΔI _{AGC}	Rec Mode, V _{CC} =5V	-1	—	1	dB
Recording current 2nd harmonics distortion CH1	D _{R2f-1}	Rec Mode, V _{CC} =5V	—	—	-35	dB
Recording current 2nd harmonics distortion CH2	D _{R2f-2}	Rec Mode, V _{CC} =5V	—	—	-35	dB
Rec Mode hold voltage	V _{S REC}	V _{CC} =5V	3.6	—	5	V
Rec Mute hold voltage	V _{S Mute}	V _{CC} =5V	2	—	2.6	V
PB circuit current	I _{PB}	PB Mode, V _{CC} =5V	—	—	25	mA
PB CH1 gain	G ₉₋₁₆	PB Mode, V _{CC} =5V	53	—	63	dB
PB CH3 gain	G ₄₋₁₈	PB Mode, V _{CC} =5V	53	—	63	dB
Inter-PB CH gain ratio	G ₉₋₁₆ - G ₄₋₁₈	PB Mode, V _{CC} =5V	-1	—	1	dB
PB input-conversion noise CH1	N _{IN9-16}	PB Mode, V _{CC} =5V	—	—	1	μV _{rms}
PB input-conversion noise CH2	N _{IN4-18}	PB Mode, V _{CC} =5V	—	—	1	μV _{rms}
PB crosstalk CH1 to CH2	CT1	PB Mode, V _{CC} =5V	—	—	-30	dB
PB crosstalk CH2 to CH1	CT2	PB Mode, V _{CC} =5V	—	—	-30	dB
PB CH1 output 2nd harmonics distortion	D _{PB2f-1}	PB Mode, V _{CC} =5V	—	—	-35	dB
PB CH2 output 2nd harmonics distortion	D _{PB2f-2}	PB Mode, V _{CC} =5V	—	—	-35	dB
PB mode hold voltage	V _{SPB}	V _{CC} =5V	0	—	1	V