

AN3664NFB

Single chip audio signal processing IC for HiFi VCR

■ Overview

The AN3664FNB is a single chip IC which performs HiFi VCR stereo audio signal processing. It incorporates the PROM to maintain an adjusting value, enabling a complete adjustment-free use.

■ Features

- High precision and adjustment-free f_0 , recording/playback level and playback BPF by adoption of built-in Zener zap PROM
- Enhanced cost performance due to incorporating external parts.

■ Applications

- HiFi VCR

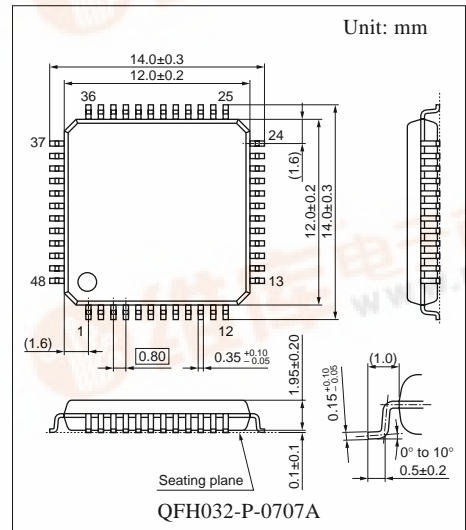

■ Block Diagram

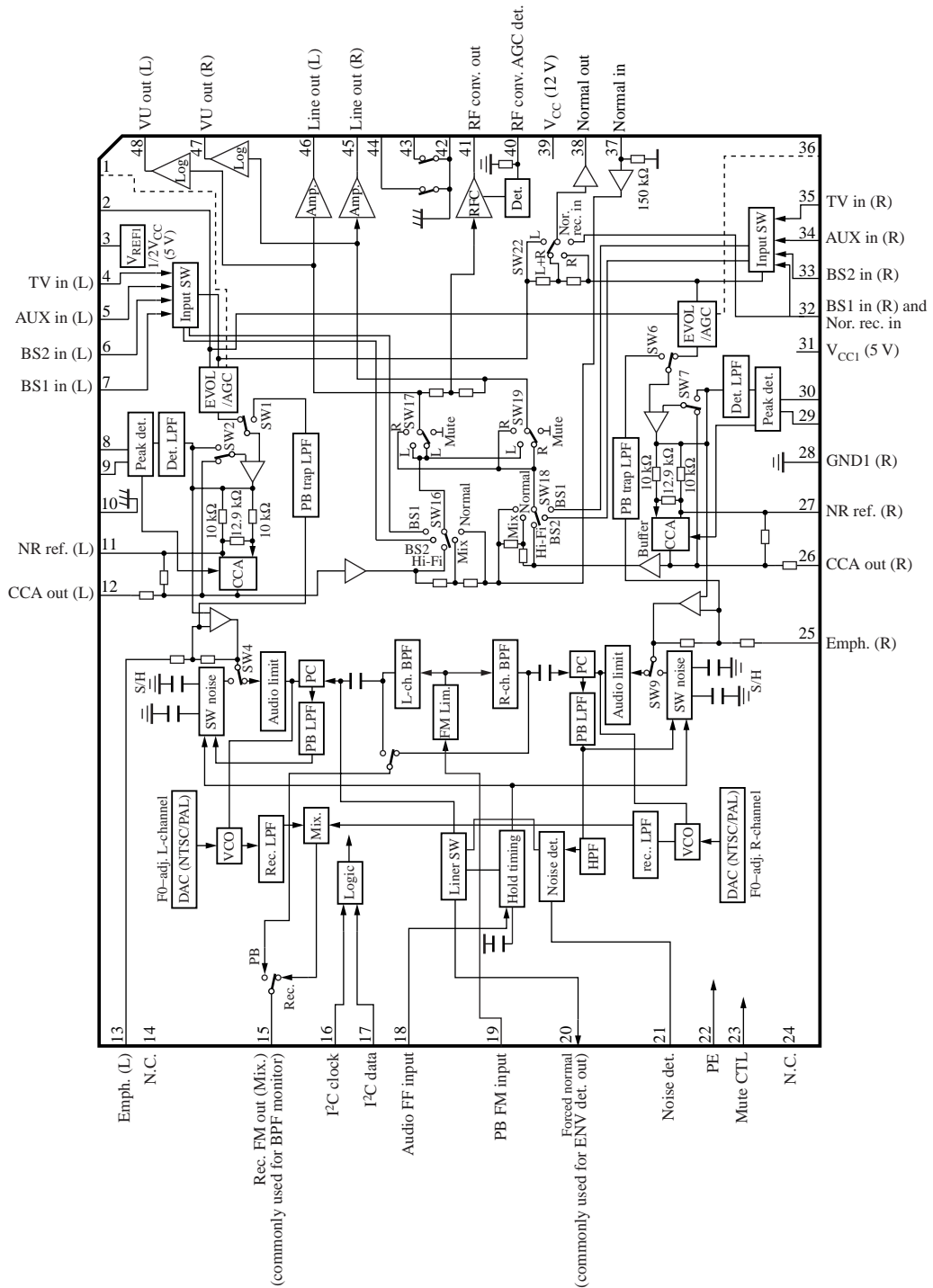

■ Pin Descriptions

Pin No.	Description	Pin No.	Description
1	Recording input volume adjusting pin	25	FM emph. / De-emph. (R-channel)
2	HiFi AGC det. pin	26	CCA output pin (R-channel: NR emph.)
3	V_{REF1} ($1/2V_{CC1}$)	27	NR ref. (R-channel)
4	TV in (L-channel)	28	GND (R-channel)
5	AUX in (L-channel)	29	NR det. 2 (R-channel)
6	BS2 in (L-channel)	30	NR det. 1 (R-channel: Weighting)
7	BS1 in (L-channel)	31	V_{CC} ($V_{CC1} = 5\text{ V}$)
8	NR det. 1 (L-channel: Weighting)	32	BS1 in (R-channel) and Normal recording in
9	NR det. 2 (L-channel)	33	BS2 in (R-channel)
10	GND (L-channel)	34	AUX in (R-channel)
11	NR ref. (L-channel)	35	TV in (R-channel)
12	CCA output pin (L-channel: NR emph.)	36	Recording input volume adjusting pin
13	FM emph. / De-emph. (L-channel)	37	Normal audio input
14	N.C.	38	Normal audio output
15	Rec. FM output / PB BPF monitor	39	V_{CC} ($V_{CC2} = 12\text{ V}$)
16	Serial clock input	40	RF conv. AGC det.
17	Serial data input	41	RF conv. amp. output
18	Head switching pulse input for FM audio	42	GND
19	Playback FM input	43	Output mute (R-channel)
20	Envelope det. and forced normal output	44	Output mute (L-channel)
21	Normal judgement noise detection	45	Line amp. output (R-channel)
22	PE	46	Line amp. output (L-channel)
23	Output mute CTL	47	LOG amp. output (R-channel)
24	Resistor selection pin (or N.C. on use)	48	LOG amp. output (L-channel)

■ Absolute Maximum Ratings

Parameter	Symbol	Rating	Unit
Supply voltage	V_{CC1}	5.5	V
	V_{CC2}	13.0	
Power dissipation ^{*1, 2}	P_D	639	mW
Operating ambient temperature ^{*1}	T_{opr}	-20 to +75	°C
Storage temperature ^{*1}	T_{stg}	-55 to +150	°C

Note) 1. The reverse insertion of this IC will cause its breakdown.

2. *1: Except for the power dissipation, operating ambient temperature and storage temperature, all ratings are for $T_a = 25^\circ\text{C}$.

*2: The power dissipation shown is the value for $T_a = 75^\circ\text{C}$.

■ Recommended Operating Range

Parameter	Symbol	Range	Unit
Supply voltage	V_{CC1}	4.5 to 5.3	V
	V_{CC2}	8.0 to 12.5	

■ Electrical Characteristics at $V_{CC1} = 5\text{ V}$, $V_{CC2} = 12\text{ V}$, $T_a = 25^\circ\text{C}$

Parameter	Symbol	Conditions	Min	Typ	Max	Unit
Circuit current (5 V) at recording	I_{CCR1}	Recording mode Measurement after adjusting f_O	80	95	110	mA
Circuit current (12 V) at recording	I_{CCR2}	Recording mode Measurement after adjusting f_O	7	9	11	mA
Circuit current (5 V) at playback	I_{CCP1}	Playback mode Measurement after adjusting f_O	80	100	120	mA
Circuit current (12 V) at playback	I_{CCP2}	Playback mode Measurement after adjusting f_O	7	9	11	mA
ENC out level 1-L	VHRO1L	$V_{IN} = -30\text{ dBFS}$, 1 kHz DIN audio, Vol. = 5 V	-12.5	-11.0	-9.5	dBFS
ENC out level 1-R	VHRO1R	$V_{IN} = -30\text{ dBFS}$, 1 kHz DIN audio, Vol. = 5 V	-12.5	-11.0	-9.5	dBFS
ENC out level 3-L	VHRO3L	$V_{IN} = -90\text{ dBFS}$, 1 kHz, DIN audio Vol. = 5 V, VHRO3L/VHRO1L	-33.0	-30.0	-27.0	dB
ENC out level 3-R	VHRO3R	$V_{IN} = -90\text{ dBFS}$, 1 kHz, DIN audio Vol. = 5 V, VHRO3R/VHRO1R	-33.0	-30.0	-27.0	dB
Normal recording out level	VNRO	$V_{IN} = -20\text{ dBFS}$, 1 kHz Normal out	-21.5	-20.0	-18.5	dBFS
Volume level L (Gain = mode 1)	VVOLL	$V_{IN} = -20\text{ dBFS}$, 1 kHz L-out, Gain = 1, Vol. = 3 V	-8.0	-6.0	-4.0	dBFS
Volume level R (Gain = mode 1)	VVOLR	$V_{IN} = -20\text{ dBFS}$, 1 kHz L-out, Gain = 1, Vol. = 3 V	-8.0	-6.0	-4.0	dBFS
Vol. level L/R balance	BVOL	VVOLL - VVOLR	-1.2	0.0	1.2	dB
Volume maximum level L	VOMAXL	$V_{IN} = -20\text{ dBFS}$, 1 kHz Gain = 1, Vol. = 5 V	2.5	4.0	5.5	dBFS
Volume maximum level R	VOMAXR	$V_{IN} = -20\text{ dBFS}$, 1 kHz Gain = 1, Vol. = 5 V	2.5	4.0	5.5	dBFS
Volume minimum level L	VOMINL	$V_{IN} = -20\text{ dBFS}$, 1 kHz Gain = 1, Vol. = 0 V VOMINL/VOMAXL	—	—	-63.0	dB
Volume minimum level R	VOMINR	$V_{IN} = -20\text{ dBFS}$, 1 kHz Gain = 1, Vol. = 0 V VOMINR/VOMAXR	—	—	-63.0	dB
HiFi AGC mode EE level L	VAGCEL	$V_{IN} = -20\text{ dBFS}$, 1 kHz Gain = 1, Vol. = 3 V	-8.0	-6.0	-4.0	dBFS
HiFi AGC mode EE level R	VAGCER	$V_{IN} = -20\text{ dBFS}$, 1 kHz Gain = 1, Vol. = 3 V	-8.0	-6.0	-4.0	dBFS

■ Electrical Characteristics at $V_{CC1} = 5\text{ V}$, $V_{CC2} = 12\text{ V}$, $T_a = 25^\circ\text{C}$ (continued)

Parameter	Symbol	Conditions	Min	Typ	Max	Unit
HiFi AGC level L	VAGCL	$V_{IN} = -2\text{ dBFS}$, 1 kHz Gain = 1, Vol. = 3 V	-2.0	0	2.0	dB
HiFi AGC level R	VAGCR	$V_{IN} = -2\text{ dBFS}$, 1 kHz Gain = 1, Vol. = 3 V	-2.0	0	2.0	dB
Line out Gain = mode 2 level L	VGHL	$V_{IN} = -20\text{ dBFS}$, 1 kHz BS1 monitor mode	-9.0	-7.5	-6.0	dB
Line out Gain = mode 2 level R	VGHL	$V_{IN} = -20\text{ dBFS}$, 1 kHz BS1 monitor mode	-9.0	-7.5	-6.0	dB
Line out THD L	THRML	$V_{IN} = -20\text{ dBFS}$, 1 kHz Gain = 1, Vol. = 3 V	—	—	0.1	%
Line out THD R	THMR	$V_{IN} = -20\text{ dBFS}$, 1 kHz Gain = 1, Vol. = 3 V	—	—	0.1	%
Line out Vo-maximum L	VMLOL	$f_{IN} = 1\text{ kHz}$, Gain = 1, Vol. = 3 V At output THD 3%	10.0	—	—	dB
Line out Vo-maximum R	VMLOR	$f_{IN} = 1\text{ kHz}$, Gain = 1, Vol. = 3 V At output THD 3%	10.0	—	—	dB
ENC out Vo-maximum L	VMFEL	$f_{IN} = 1\text{ kHz}$, Vol. = 5 V At output THD 3%	-4.0	—	—	dB
ENC out Vo-maximum R	VMFER	$f_{IN} = 1\text{ kHz}$, Vol. = 5 V At output THD 3%	-4.0	—	—	dB
RF conv. out level	VRFC	$V_{IN} = -20\text{ dBFS}$, 1 kHz BS2 monitor mode	-9.0	-6.0	-3.0	dB
Line out S/N L	NHLOL	$R_G = 2.2\text{ k}\Omega$, DIN audio Gain = 1, Vol. = 3 V	75.0	—	—	dB
Line out S/N R	NHLOR	$R_G = 2.2\text{ k}\Omega$, DIN audio Gain = 1, Vol. = 3 V	75.0	—	—	dB
Inter input crosstalk 1 ^{*1} (TV-in select)	CTIT	AUX, BS1 and BS2 in = -10 dBFS 1 kHz, DIN audio, Vol. = 3 V CTIT - VRFC - 10 dB	—	—	-70.0	dB
Inter input crosstalk 2 ^{*1} (AUX-in select)	CTIA	TV, BS1 and BS2 in = -10 dBFS 1 kHz, DIN audio, Vol. = 3 V CTIA - VRFC - 10 dB	—	—	-70.0	dB
Inter input crosstalk 3 ^{*1} (BS1-in select)	CTIB1	TV, AUX and BS2 in = -10 dBFS 1 kHz, DIN audio, Vol. = 3 V CTIB1 - VRFC - 10 dB	—	—	-70.0	dB
Inter input crosstalk 4 ^{*1} (BS2-in select)	CTIB2	TV, AUX and BS1 in = -10 dBFS 1 kHz, DIN audio, Vol. = 3 V CTIB2 - VRFC - 10 dB	—	—	-70.0	dB
Crosstalk between channels R → L ^{*1}	CTTRL	TV in R-channel = -10 dBFS, 1 kHz DIN audio, Vol. = 3 V CTTRL - VVOLL - 10 dB	—	—	-65.0	dB

Note) *1: 10 dB should be reduced from the calculation result because of +10 dB increased input.

■ Electrical Characteristics at $V_{CC1} = 5\text{ V}$, $V_{CC2} = 12\text{ V}$, $T_a = 25^\circ\text{C}$ (continued)

Parameter	Symbol	Conditions	Min	Typ	Max	Unit
Crosstalk between channels L → R *1	CTTRR	TV in L-channel = -10 dBs, 1 kHz DIN audio, Vol. = 3 V CTTLR - VVOLR - 10 dB	—	—	-65.0	dB
Output mode crosstalk 1 *1 (Normal select)	CTHN	TV, BS1 and BS2 in = -10 dBs 1 kHz, DIN audio, Vol. = 3 V CTHN - VRFC - 10 dB	—	—	-65.0	dB
Output mode crosstalk 2 *1 (HiFi select)	CTNH	Pin 37, BS1 and BS2 in = -10 dBs 1 kHz, DIN audio, Vol. = 3 V CTNH - VRFC - 10 dB	—	—	-65.0	dB
Output mode crosstalk 3 *1 (BS1 monitor mode)	CTB1	Pin 37, TV and BS2 in = -10 dBs 1 kHz, DIN audio, Vol. = 3 V CTB1 - VRFC - 10 dB	—	—	-65.0	dB
Output mode crosstalk 4 *1 (BS2 monitor mode)	CTB2	Pin 37, TV and BS1 in = -10 dBs 1 kHz, DIN audio, Vol. = 3 V CTB2 - VRFC - 10 dB	—	—	-65.0	dB
Crosstalk between ENC out channels (R → L)	CTENRL	TV in R-channel = -10 dBs, 1 kHz DIN audio, Vol. = 3 V CTENRL - VHRO1L - 5 dB	—	—	-37.0	dB
Crosstalk between ENC out channels (L → R)	CTENLR	TV in R-channel = -10 dBs, 1 kHz DIN audio, Vol. = 3 V CTENLR - VHRO1R - 5 dB	—	—	-37.0	dB
Output muting ratio L *1	MUTEL	TV in = -10 dBs, 1 kHz Gain = 1, DIN audio, Vol. = 3 V MUTEL - VVOLL - 10 dB	—	—	-65.0	dB
Output muting ratio R *1	MUTER	TV in = -10 dBs, 1 kHz Gain = 1, DIN audio, Vol. = 3 V MUTER - VVOLR - 10 dB	—	—	-65.0	dB
VCO output frequency L (NTSC)	FNL	NTSC mode, $V_{19} = 5\text{ V}$ Non-modulation After PROM adjustment	1.295	1.300	1.305	MHz
VCO output frequency R (NTSC)	FNR	NTSC mode, $V_{19} = 0\text{ V}$ Non-modulation After PROM adjustment	1.695	1.700	1.705	MHz
VCO output frequency L (PAL)	FPL	PAL mode, $V_{19} = 5\text{ V}$ Non-modulation After PROM adjustment	1.395	1.400	1.405	MHz
VCO output frequency R (PAL)	FPR	PAL mode, $V_{19} = 0\text{ V}$ Non-modulation After PROM adjustment	1.795	1.800	1.805	MHz
VCO output amplitude L	VOVCOL	NTSC mode, 1.3 MHz Non-modulation	30	53	70	mV[p-p]

Note) *1: 10 dB should be reduced from the calculation result because of +10 dB increased input.

■ Electrical Characteristics at $V_{CC1} = 5\text{ V}$, $V_{CC2} = 12\text{ V}$, $T_a = 25^\circ\text{C}$ (continued)

Parameter	Symbol	Conditions	Min	Typ	Max	Unit
VCO output amplitude R	VOVCOR	NTSC mode, 1.7 MHz Non-modulation	135	185	235	mV[p-p]
VCO output L/R mix. ratio L	FNLN	NTSC mode Serial control: D05 = 0, D04 = 0	9.5	11.0	12.5	dB
VCO output L/R mix. ratio R	FNRN	NTSC mode Serial control: D05 = 1, D04 = 1	6.5	8.0	9.5	dB
Limiter level 1-L (NTSC mode)	LIMN1L	Pin 19 = 5 V, Pin 13 = 5 V $LIMN1L - f_{OL}$	-160	-140	-120	kHz
Limiter level 1-R (NTSC mode)	LIMN1R	Pin 19 = 0 V, Pin 25 = 5 V $LIMN1R - f_{OR}$	-160	-140	-120	kHz
Limiter level 2-L (NTSC mode)	LIMN2L	Pin 19 = 5 V, Pin 13 = 0 V $LIMN2L - f_{OL}$	120	140	160	kHz
Limiter level 2-R (NTSC mode)	LIMN2R	Pin 19 = 0 V, Pin 25 = 0 V $LIMN2R - f_{OR}$	120	140	160	kHz
FM deviation L	DEVL	$V_{IN} = -30\text{ dBFS}$, 1 kHz Vol. = 5 V, Pin 19 = 5 V	44.0	50.0	56.0	kHz
FM deviation R	DEVR	$V_{IN} = -30\text{ dBFS}$, 1 kHz Vol. = 0 V, Pin 19 = 5 V	44.0	50.0	56.0	kHz
FM deviation L/R ratio	DEVLR	$DEVR - DEVL$	-6.0	0.0	6.0	kHz
FM modulation distortion L	THFEL	$V_{IN} = -20\text{ dBFS}$, 1 kHz Vol. = 3 V, FM RF out	—	—	0.8	%
FM modulation distortion R	THFER	$V_{IN} = -20\text{ dBFS}$, 1 kHz Vol. = 3 V, FM RF out	—	—	0.8	%
FM modulation S/N L	NHFEL	$R_G = 2.2\ \Omega$, DIN audio, Vol. = 3 V FM RF out, DEVL/NHFEL	35	—	—	dB
FM modulation S/N R	NHFER	$R_G = 2.2\ \Omega$, DIN audio, Vol. = 3 V FM RF out, DEVR/NHFER	35	—	—	dB
1.3 MHz BPF frequency characteristics 1 *2	BPF11	BPF monitor (L-channel) NTSC mode, $f_C = 1.3\text{ MHz}$	100	155	190	mV[p-p]
1.3 MHz BPF frequency characteristics 2 *2	BPF12	$f_C = 1.45\text{ MHz}$ BPF12/BPF11	-9.0	-3.0	1.0	dB
1.3 MHz BPF frequency characteristics 3 *2	BPF13	$f_C = 1.15\text{ MHz}$ BPF13/BPF11	-4.0	-1.0	2.0	dB
1.3 MHz BPF frequency characteristics 5 *2	BPF15	V (1.05M) / V (1.45M)	-15.0	-7.5	4.0	dB
1.7 MHz BPF frequency characteristics 1 *2	BPF21	BPF monitor (R-channel) NTSC mode, $f_C = 1.7\text{ MHz}$	90	135	170	mV[p-p]
1.7 MHz BPF frequency characteristics 2 *2	BPF22	$f_C = 1.85\text{ MHz}$ BPF22/BPF21	-6.0	0.0	3.5	dB
1.7 MHz BPF frequency characteristics 3 *2	BPF23	$f_C = 1.55\text{ MHz}$ BPF23/BPF21	-7.0	-3.0	0.5	dB

Note) *2: PB-FM input level: Single 140 mV[p-p], Mix. 280 mV[p-p]

■ Electrical Characteristics at $V_{CC1} = 5\text{ V}$, $V_{CC2} = 12\text{ V}$, $T_a = 25^\circ\text{C}$ (continued)

Parameter	Symbol	Conditions	Min	Typ	Max	Unit
1.4 MHz BPF frequency characteristics 1 * ²	BPF31	BPF monitor (L-channel) PAL mode, $f_C = 1.4\text{ MHz}$	100	155	190	mV[p-p]
1.4 MHz BPF frequency characteristics 2 * ²	BPF32	$f_C = 1.55\text{ MHz}$ BPF32/BPF31	-9.0	-3.0	1.0	dB
1.4 MHz BPF frequency characteristics 3 * ²	BPF33	$f_C = 1.25\text{ MHz}$ BPF33/BPF31	-4.0	-1.0	2.0	dB
1.4 MHz BPF frequency characteristics 5 * ²	BPF35	1.15 MHz/1.55 MHz	-15.0	-7.5	4.0	dB
1.8 MHz BPF frequency characteristics 1 * ²	BPF41	BPF monitor (R-channel) PAL mode, $f_C = 1.8\text{ MHz}$	90	135	170	mV[p-p]
1.8 MHz BPF frequency characteristics 2 * ²	BPF42	$f_C = 1.95\text{ MHz}$ BPF42/BPF41	-6.0	0.0	3.5	dB
1.8 MHz BPF frequency characteristics 3 * ²	BPF43	$f_C = 1.65\text{ MHz}$ BPF43/BPF41	-7.0	-3.0	3.0	dB
Playback out level 1-L * ²	VHPO1L	$V_{IN} = 50\text{ kHz Dev}$, 1 kHz Line out, Gain = 1	-7.5	-6.0	-4.5	dBS
Playback out level 1-R * ²	VHPO1R	$V_{IN} = 50\text{ kHz Dev}$, 1 kHz Line out, Gain = 1	-7.5	-6.0	-4.5	dBS
Playback out level L/R ratio	BHP	VHPO1L – VHPO1R	-1.5	0.0	1.5	dB
Playback out level 3-L * ²	VHPO3L	FM in = 50 kHz, -30 dB DIN audio, Gain=1, VHPO3L/VHPO1L	-70.0	-64.0	-57.0	dB
Playback out level 3-R * ²	VHPO3R	FM in = 50 kHz, -30 dB DIN audio, Gain=1, VHPO3R/VHPO1R	-70.0	-64.0	-57.0	dB
Playback out frequency characteristics L * ²	VHPFL	In: Dev = 50 kHz, $f = 70\text{ kHz}$ DIN audio, Gain=1, VHPFL/VHPO1L	—	—	-40.0	dB
Playback out frequency characteristics R * ²	VHPFR	In: Dev = 50 kHz, $f = 70\text{ kHz}$ DIN audio, Gain=1, VHPFR/VHPO1R	—	—	-40.0	dB
Playback out distortion L * ²	THPOL	In: Dev = 100 kHz, $f = 1\text{ kHz}$ Line out, Gain = 1	—	—	0.8	%
Playback out distortion R * ²	THPOR	In: Dev = 100 kHz, $f = 1\text{ kHz}$ Line out, Gain = 1	—	—	0.8	%
Playback out S/N L * ²	NHPOL	No modulation, Line out, Gain = 1 DIN audio, VHPO1L/NHPOL	75	—	—	dB
Playback out S/N R * ²	NHPOR	No modulation, Line out, Gain = 1 DIN audio, VHPO1R/NHPOR	75	—	—	dB
Crosstalk between Playback out channels (R → L) * ²	CTPRL	$V_{IN} = 50\text{ kHz Dev}$, 1 kHz DIN audio, CTPRL/VHPO1L	—	—	-65.0	dB
Crosstalk between Playback out channels (L → R) * ²	CTPLR	$V_{IN} = 50\text{ kHz Dev}$, 1 kHz DIN audio, CTPLR/VHPO1R	—	—	-65.0	dB
DOC on level	DOC1	$f_{CL} = 1.3\text{ MHz}$ $f_{CR} = 1.7\text{ MHz} \pm 50\text{ kHz Dev}$.	10	19	30	mV[p-p]

Note) *2: PB-FM input level: Single 140 mV[p-p], Mix. 280 mV[p-p]

■ Electrical Characteristics at $V_{CC1} = 5\text{ V}$, $V_{CC2} = 12\text{ V}$, $T_a = 25^\circ\text{C}$ (continued)

Parameter	Symbol	Conditions	Min	Typ	Max	Unit
DOC hysteresis	DOC2	$f_{CL} = 1.3\text{ MHz}$ $f_{CR} = 1.7\text{ MHz} \pm 50\text{ kHz Dev.}$	0.1	2.0	6.0	dB
Forced normal on level 1 *2	ND1	$f = 150\text{ kHz}$, ND mode = 0 Dev. at $V_{20} < 0.5\text{ V}$	45	90	135	kHz Dev
VU out level 2-L	VVU2L	Line out = -27 dBs, 1 kHz Gain = 1, HiFi-AGC mode	—	—	2.0	V
VU out level 2-R	VVU2R	Line out = -27 dBs, 1 kHz Gain = 1, HiFi-AGC mode	—	—	2.0	V
VU out level 3-L	VVU3L	Line out = -27 dBs, 1 kHz Gain = 1, Normal mode	—	—	2.6	V
VU out level 3-R	VVU3R	Line out = -27 dBs, 1 kHz Gain = 1, Normal mode	—	—	2.6	V

Note) *2: PB-FM input level: Single 140 mV[p-p], Mix. 280 mV[p-p]

• Design reference data

Note) The characteristics listed below are theoretical values based on the IC design and are not guaranteed.

Parameter	Symbol	Conditions	Min	Typ	Max	Unit
Data input (high-level)	V_{HDATA}	At $V_{CC} = 5\text{ V}$	3.5	—	5	V
Data input (low-level)	V_{LDATA}	At $V_{CC} = 5\text{ V}$	0	—	1.5	V
Clock input (high-level)	V_{HCLOC}	At $V_{CC} = 5\text{ V}$	3.5	—	5	V
Clock input (low-level)	V_{LCLOC}	At $V_{CC} = 5\text{ V}$	0	—	1.5	V
Mute CTL input	V_{IHMUT}	Mute on	3.5	—	5	V
Mute CTL input	V_{ILMUT}	Mute off	0	—	1.0	V
Forced normal on level 2	ND2	$f = 150\text{ kHz}$, Mode 01 Dev. at $V_{20} < 0.5\text{ V}$	—	80	—	kHz Dev
RF conv. AGC level	VRFCAG	$V_{IN} = -10\text{ dBs}$, $f = 1\text{ kHz}$	—	-4	—	dBs
Normal REC THD	TNRO	$V_{IN} = -20\text{ dBs}$, $f = 1\text{ kHz}$	—	0.02	—	%
Normal input crosstalk 1 (Nor. REC in Select)	CTNNO	TV in = -10 dBs DIN audio	—	-80	—	dB
Normal input crosstalk 2 (Line in L/R mix. select)	CTNLR	Nor. rec. in = -10 dBs DIN audio	—	-80	—	dB
Normal input crosstalk 3 (Line in R select)	CTNRR	Nor. rec. in & TV in L = -10 dBs DIN audio	—	-80	—	dB
Normal input crosstalk 4 (Line in L select)	CTNLL	Nor. rec. in & TV in R = -10 dBs DIN audio	—	-80	—	dB
Carrier 3rd harmonic L	3HDL	RF recording out	—	-50	—	dB
Carrier 3rd harmonic R	3HDR	RF recording out	—	-50	—	dB
Limiter level PAL 1-L	LIMP1L	Pin 12 = 5 V, LIMP1L - f_{OL} (PAL)	—	-140	—	kHz
Limiter level PAL 1-R	LIMP1R	Pin 25 = 5 V, LIMP1R - f_{OR} (PAL)	—	-140	—	kHz
Limiter level PAL 2-L	LIMP2L	Pin 12 = 5 V, LIMP2L - f_{OL} (PAL)	—	-140	—	kHz
Limiter level PAL 2-R	LIMP2R	Pin 25 = 5 V, LIMP2R - f_{OR} (PAL)	—	-140	—	kHz

■ Electrical Characteristics at $V_{CC1} = 5\text{ V}$, $V_{CC2} = 12\text{ V}$, $T_a = 25^\circ\text{C}$ (continued)
• Design reference data

Note) The characteristics listed below are theoretical values based on the IC design and are not guaranteed.

Parameter	Symbol	Conditions	Min	Typ	Max	Unit
1.3 MHz BPF frequency characteristics 4	BPF14	1.7 MHz/1.3 MHz	—	-32	—	dB
1.3 MHz BPF frequency characteristics 6	BPF16	1.55 MHz/1.15 MHz	—	-10	—	dB
1.7 MHz BPF frequency characteristics 4	BPF24	2.1 MHz/1.7 MHz	—	-18	—	dB
1.7 MHz BPF frequency characteristics 5	BPF25	1.3 MHz/1.7 MHz	—	-30	—	dB
1.7 MHz BPF frequency characteristics 6	BPF26	1.45 MHz/1.85 MHz	—	-18	—	dB
Envelope out 1	ENV1	$V_{IN} = 70\text{ mV[p-p]}$, Mix. Measure V_{21}	—	1.0	—	V
Envelope out 2	ENV2	$V_{IN} = 280\text{ mV[p-p]}$, Mix. Measure V_{21} , $ENV2 - ENV1$	—	1.7	—	V
REC → PB crosstalk	CTRP	$f_C = 140\text{ mV[p-p]}$, Mix. TV in = -10 dBs, PB	—	-80	—	dB
1.4 MHz BPF frequency characteristics 4	BPF34	PAL 1.8 MHz/1.4 MHz	—	-32	—	dB
1.4 MHz BPF frequency characteristics 6	BPF36	PAL 1.65 MHz/1.25 MHz	—	-10	—	dB
1.8 MHz BPF frequency characteristics 4	BPF44	PAL 2.2 MHz/1.8 MHz	—	-18	—	dB
1.8 MHz BPF frequency characteristics 5	BPF45	PAL 1.4 MHz/1.8 MHz	—	-30	—	dB
1.8 MHz BPF frequency characteristics 6	BPF46	PAL 1.55 MHz/1.95 MHz	—	-16	—	dB
VU out level L	VUOTL	$V_{IN} = -20\text{ dBs}$, 1 kHz	—	3.5	—	V
VU out level R	VUOTR	$V_{IN} = -20\text{ dBs}$, 1 kHz	—	3.5	—	V
BPF group delay difference ($f_0 \pm 100\text{ kHz}$)	GDBPF	Difference of $f_0 \pm 100\text{ kHz}$	—	500	—	ns
VCO f_0 dependence on temperature	TVCO	$f_0(T = -10^\circ\text{C}) - f_0(T = 75^\circ\text{C})$	—	5	—	kHz
Playback out level 1-L (PAL)	VPO1LP	$V_{IN} = 50\text{ kHz}$, Dev 1 kHz Line out, Gain = high	—	-6.0	—	dBs
Playback out level 1-R (PAL)	VPO1RP	$V_{IN} = 50\text{ kHz}$, Dev 1 kHz Line out, Gain = high	—	-6.0	—	dBs
Normal-off delay time	MON	Defined in FF timing	—	3	—	FF
ENC attack time	ENAT	$f = 5\text{ kHz}$, $V_{IN} = \text{Typ. } -20\text{ dB}$	—	4	—	ms
ENC recovery time	ENRT	$f = 5\text{ kHz}$, $V_{IN} = \text{Typ. } -20\text{ dB}$	—	65	—	ms
Hold pulse width	HPUL		—	10	—	μs

■ Electrical Characteristics at $V_{CC1} = 5\text{ V}$, $V_{CC2} = 12\text{ V}$, $T_a = 25^\circ\text{C}$ (continued)

• Design reference data

Note) The characteristics listed below are theoretical values based on the IC design and are not guaranteed.

Parameter	Symbol	Conditions	Min	Typ	Max	Unit
VCO output R/L mix. ratio 2	VMIX2	D05 = 0, D04 = 1	—	10	—	dB
VCO output R/L mix. ratio 3	VMIX3	D05 = 0, D04 = 1	—	9	—	dB
Envelope output DC level in forced normal mode	V_{ENVN}	DC measurement (forced normal) Pin 20 DC potential measurement	—	0.15	—	V
Envelope output impedance in forced normal mode	R_{NEFN}	DC measurement (forced normal) Pin 20 impedance	—	400	—	Ω
Output mute on impedance L	Z_{OML}	DC measurement Pin 44 impedance	—	10	—	Ω
Output mute on impedance R	Z_{OMR}	DC measurement Pin 43 impedance	—	10	—	Ω

■ Terminal Equivalent Circuits

Pin No.	Equivalent circuit	Description	Voltage
1		E-VOL CTL (L-channel)	3 V
2		HiFi-AGC det.	No fixed
3		$1/2 V_{CC1} V_{REF1}$: $1/2 V_{CC1}$ pin, but concurrently used for generation of ref. DC shift cur- rent of $1/2 V_{CC2}$.	2.5 V

■ Terminal Equivalent Circuits (continued)

Pin No.	Equivalent circuit	Description	Voltage
4		TV in (L-channel): Audio signal Typical: -20 dBS (1 kHz)	2.5 V
5		AUX in (L-channel): Audio signal Typical: -20 dBS (1 kHz)	
6		BS2 in (L-channel): Audio signal Typical: -20 dBS (1 kHz)	2.5 V
7		BS1 in (L-channel): Audio signal Typical: -20 dBS (1 kHz)	
8		NR det. 1 (L-channel): Sets the weighting time constant for a noise reduction. Shown below is the CR constant setting example in the application circuit model:	2.5 V
9		NR det. 2 (L-channel)	1.35 V at no signal
10	—	GND1 (L-channel)	0 V

■ Terminal Equivalent Circuits (continued)

Pin No.	Equivalent circuit	Description	Voltage
11		<p>NR ref. (L-channel): This pin specifies a reference voltage for HiFi signal system.</p>	2.5 V
12		<p>CCA out (L-channel): Audio signal Typical: -20 dBS (1 kHz)</p>	2.5 V
13		<p>Emph. NF (L-channel) In recording, it enables you to evaluate without an external capacitor as a monitor pin for encode output. Typical: -11 dBS (1 kHz) The time constant in FM emphasis is determined by an external capacitance and an inside resistor.</p>	2.5 V
14	—	N.C.	—

■ Terminal Equivalent Circuits (continued)

Pin No.	Equivalent circuit	Description	Voltage
15		<p>REC FM out PB BPF monitor:</p> <p>The FM output in recording is an R+L mix output. The mixing ratio can be switched to 4 stages in serial. Pin 19 can output 5 V for L-channel and 0 V for R-channel (before mixing) independently. In playback, the BPF monitor output is linked with output channel switching. The output impedance is about 80 Ω.</p>	<p>2.5 V at recording</p> <p>2.5 V at BPF monitor</p> <p>0 V at PB stereo</p>
16		<p>Clock in:</p> <p>High: 3.5 V to 5.0 V Low: 0 V to 1.5 V</p>	<p>Serial clock</p>
17		<p>Data in:</p> <p>High: 3.5 V to 5.0 V Low: 0 V to 1.5 V</p>	<p>Serial data</p>
18		<p>Audio FF: (head switching pulse input)</p> <p>High: 3.5 V to 5.0 V Low: 0 V to 1.5 V</p>	
19		<p>PB FM in:</p> <p>Input impedance: approx. 20 kΩ Typical input carrier level: 140 mV[p-p] (280 mV[p-p] at mixing)</p>	<p>2.5 V</p>

■ Terminal Equivalent Circuits (continued)

Pin No.	Equivalent circuit	Description	Voltage
20		<p>Envelope det. out Forced normal out: Terminal voltage varies according to L-channel input carrier level. At forced normal, output impedance is approx. 400 Ω.</p>	<p>1.8 V at typical carrier level input 0 V at forced normal</p>
21		<p>Noise det.: Detects the output which is the demodulated R-channel noise output through an built-in second order HPF ($f_c = 150K$), with an external capacitor.</p>	<p>1.9 V or more</p>
22		<p>PE</p>	<p>—</p>
23		<p>Mute CTL: Mute on: 3.5 V or more Mute off: 1.0 V or less</p>	<p>No fixed</p>
24		<p>Selective resistor pin: N.C. is possible at normal use.</p>	<p>0 V</p>
25	<p>Refer to pin 13</p>	<p>Emph. NF (R-channel): Refer to pin 13</p>	<p>Refer to pin 13</p>
26	<p>Refer to pin 12</p>	<p>CCA out (R-channel): Refer to pin 12</p>	<p>Refer to pin 12</p>

■ Terminal Equivalent Circuits (continued)

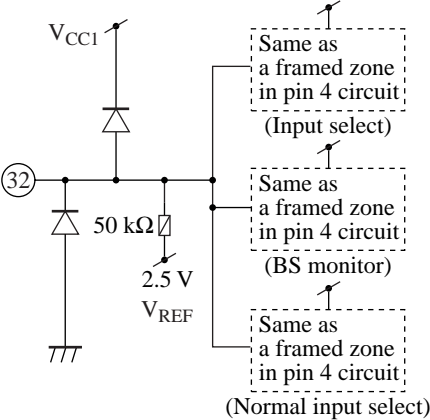
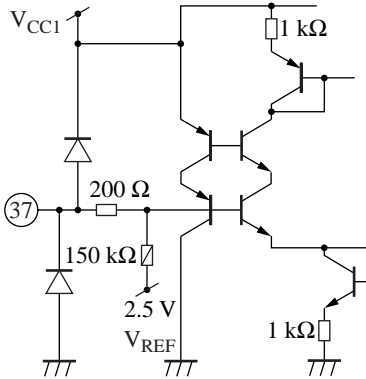
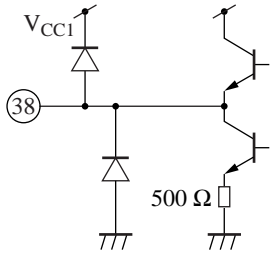
Pin No.	Equivalent circuit	Description	Voltage
27	Refer to pin 11	NR ref. (R-channel): Refer to pin 11	Refer to pin 11
28	—	GND1 (R-channel)	Refer to pin 10
29	Refer to pin 9	NR det. 2 (R-channel)	Refer to pin 9
30	Refer to pin 8	NR det. 1 (R-channel): Refer to pin 8	Refer to pin 8
31	—	V _{CC1} (R-channel)	5 V
32		<p>BS1 in (R-channel) and Nor. rec. in: Audio signal Typical: -20 dBS (1 kHz)</p> <p>Note) Because of using the same pin for both R-channel BS1 and Nor. rec. in, HiFi input is 3 input/ch. in using as normal input.</p>	
33	Refer to pin 6	BS2 in (R-channel): Refer to pin 6	Refer to pin 6
34	Refer to pin 4	AUX in (R-channel): Refer to pin 4	Refer to pin 4
35	Refer to pin 4	TV in (R-channel): Refer to pin 4	Refer to pin 4
36	Refer to pin 1	E-VOL CTL (R-channel): Refer to pin 1	Refer to pin 1
37		Normal in	2.5 V
38		Normal out	2.5 V
39	—	V _{CC2}	12 V or 9 V

■ Terminal Equivalent Circuits (continued)

Pin No.	Equivalent circuit	Description	Voltage
40		RFC AGC det.: Recovery current source built in	0 V at no signal 1 V at standard signal input (+10 dB)
41		RF conv. out: Output impedance: approx. 20 Ω	6.0 V at using $V_{CC2} = 12\text{ V}$ 4.5 V at using $V_{CC2} = 9\text{ V}$
42	—	GND2	0 V
43		Mute R: Impedance at mute: 20 Ω or less	Not fixed
44		Mute L: Impedance at mute: 20 Ω or less	
45		Line out R: Output impedance: approx. 20 Ω	6.0 V at using $V_{CC2} = 12\text{ V}$ 4.5 V at using $V_{CC2} = 9\text{ V}$
46		Line out L: Output impedance: approx. 20 Ω	

■ Terminal Equivalent Circuits (continued)

Pin No.	Equivalent circuit	Description	Voltage
47		VU out R: Half-wave rectification output	3.5 V at standard signal input (-20 dBS)
48		VU out L: Half-wave rectification output	

■ Application Notes

• Serial control timing specification

1. Start and stop conditions

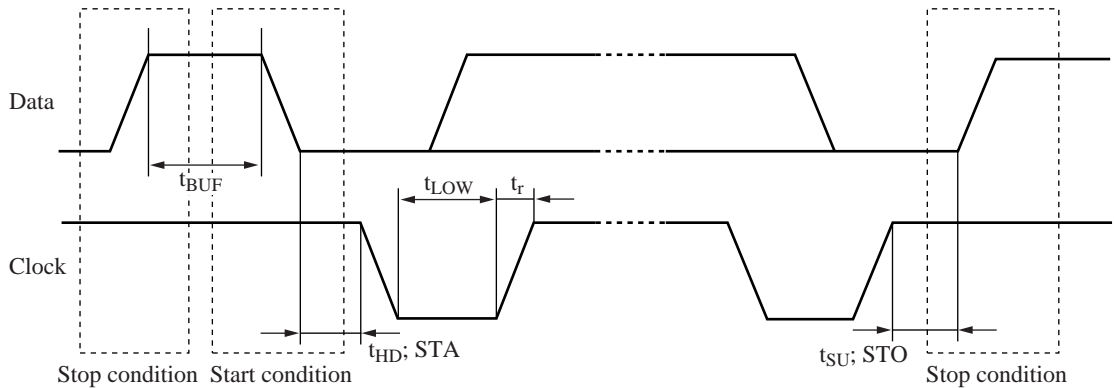

2. Data recognition condition

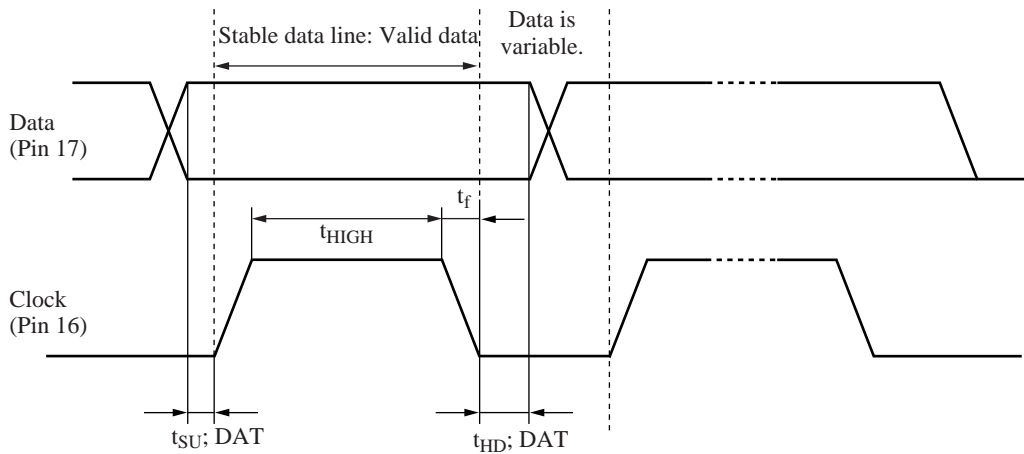

3. Recommended operation condition

Parameter	Symbol	Min	Max	Unit
Bus free time between stop and start conditions	t_{BUF}	4.7	—	μs
Hold time start condition (First clock pulse is generated after this period.)	$t_{HD; STA}$	4.0	—	μs
Clock low state hold time	t_{LOW}	4.7	—	μs
Rise time of data and clock signals	t_r	—	1 000	ns
Setup time of stop condition	$t_{SU; STO}$	4.0	—	μs
Data setup time	$t_{SU; DAT}$	250	—	ns
Clock high state hold time	t_{HIGH}	4.0	—	μs
Fall time of data and clock signals	t_r	—	300	ns
Data hold time	$t_{HD; DAT}$	5.0	—	μs
Clock frequency	f_{SCL}	0	100	kHz

■ Application Notes (continued)

• Serial control timing specification (continued)

4. Data specification

1) Slave address:

1	1	1	0	1	0	0	0
---	---	---	---	---	---	---	---

2) Slave address format

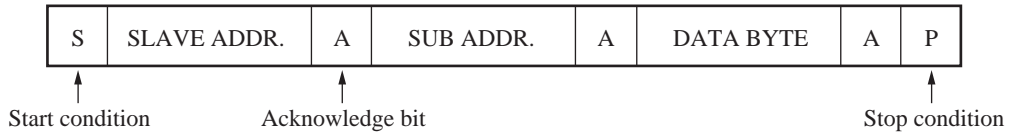

3) Function (sub-address byte and data byte format)

Note) The underlined values show an initial state at power on.

AN3664NFB serial mode

Data Sub- address	D7	D6	D5	D4	D3	D2	D1	D0
(HEX)	Recording/ Playback	BS monitor input	Recording FM mix. ratio		HiFi input select		Nor. input select	
00	0 = Playback <u>1 = Recording</u>	<u>0 = BS1</u> 1 = BS2	<u>(0, 0) = 11 dB (R/L)</u> (0, 1) = 10 dB (1, 0) = 9 dB (1, 1) = 8 dB		<u>(0, 0) = TV</u> (0, 1) = AUX (1, 0) = BS2 (1, 1) = BS1		(0, 0) = Nor. rec. in (0, 1) = R-channel (1, 0) = L-channel <u>(1, 1) = L/R mix.</u>	
01	NTSC/PAL	Line amp gain setting	DOC select	Nor. detection*1	Output mode select		Output channel select (SW 17, 19)	
01	<u>0 = NTSC</u> 1 = PAL	<u>0 = -6.0 dBs</u> 1 = -7.5 dBs	<u>0 = On</u> 1 = Off	<u>0 = 2.55 V</u> 1 = 2.35 V	<u>(0, 0) = HiFi</u> (0, 1) = Mix. (1, 0) = Normal (1, 1) = BS monitor		<u>(0, 0) = Stereo</u> (0, 1) = L-channel (1, 0) = R-channel (1, 1) = ××××	
02	BPF L-channel adj.*2		ND select forced normal on/off	HiFi AGC	Test*2	Zap mode*2	VCC2 select	Power save
02	(0, 0) = Prohibition (0, 1) = Low shift (1, 0) = High shift (1, 1) = Typical		<u>0 = On</u> 1 = Off	<u>0 = Off</u> 1 = On	<u>0 = Off</u> 1 = On	<u>0 = DAC</u> 1 = PROM	<u>0 = 9 V</u> <u>1 = 12 V</u>	<u>0 = Off</u> 1 = On
03	BPF R-channel adj.*2		D53	D43	D33	D23	D13	D03
03	(0, 0) = Prohibition (0, 1) = Low shift (1, 0) = High shift (1, 1) = Typical		DACR(5)*2 NTSC	DACR(4)*2 NTSC	DACR(3)*2 NTSC	DACR(2)*2 NTSC	DACR(1)*2 NTSC	DACR(0)*2 NTSC
04	PBOUT L-channel adj.*2		D54	D44	D34	D24	D14	D04
04	(0, 0) = Prohibition (0, 1) = High Shift (1, 0) = Low Shift (1, 1) = Typical		DACL(5)*2 NTSC	DACL(4)*2 NTSC	DACL(3)*2 NTSC	DACL(2)*2 NTSC	DACL(1)*2 NTSC	DACL(0)*2 NTSC
05	PBOUT R-channel adj.*2		D55	D45	D35	D25	D15	D05
05	(0, 0) = Prohibition (0, 1) = High shift (1, 0) = Low shift (1, 1) = Typical		DACR(2)*2 PAL	DACR(1)*2 PAL	DACR(0)*2 PAL	DACL(2)*2 PAL	DACL(1)*2 PAL	DACL(0)*2 PAL

Note) *1: Described as 21-pin DC voltage.

*2: Used for the inspection.

■ Application Notes (continued)

- Serial control timing specification (continued)

5. Usage notes

Serial data transmission

You need to send the start and stop conditions every time you send one line of data.

To change a serial mode setting, you have only to send one line of data on the part to be changed.

<Example: in case of sending all data of four lines>

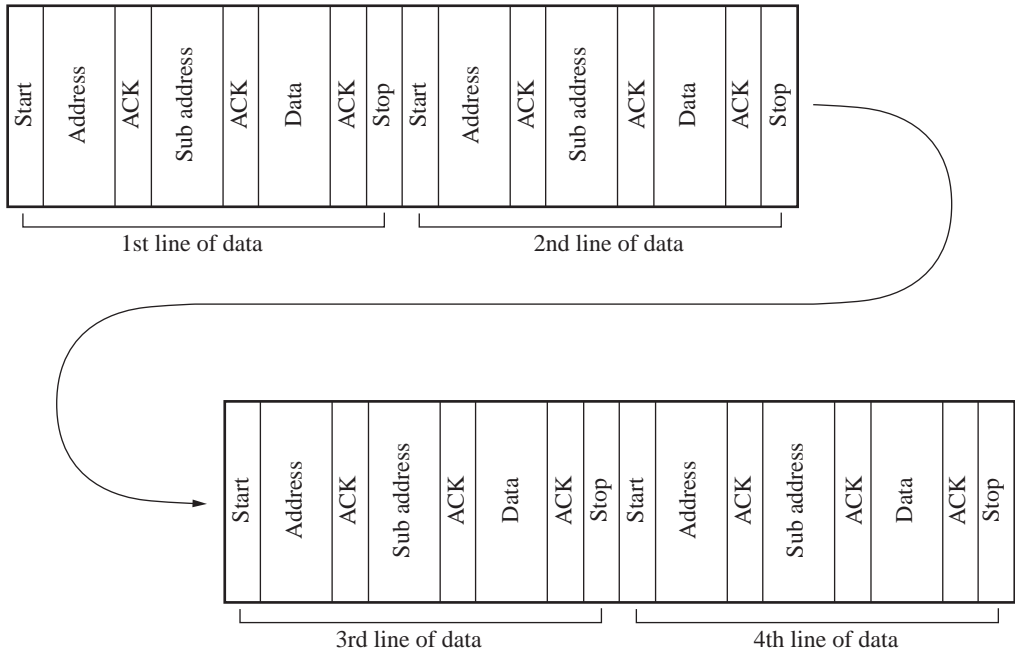

Application Circuit Example

