

# AN3672NFBP

Audio signal processor IC for HiFi VCR  
incorporating EIAJ sound multiplex system

## ■ Overview

The AN3672NFBP is a HiFi audio signal processor IC (NTSC) incorporating EIAJ sound multiplex decoder and pre/recording amplifier. An adjustment-free sound multiplex decoder is realized through both of  $f_0$  automatic adjustment of high precision VCO by a reference signal ( $f_{SC}$ ) and an SIF (4.5 MHz inter-carrier sound intermediate frequency) signal input.

## ■ Features

- Built-in EIAJ sound multiplex decoder
- Full adjustment-free by SIF signal input
- $f_0$  automatic adjustment of high precision VCO
- Built-in pre/recording amplifier

## ■ Applications

- HiFi VCR

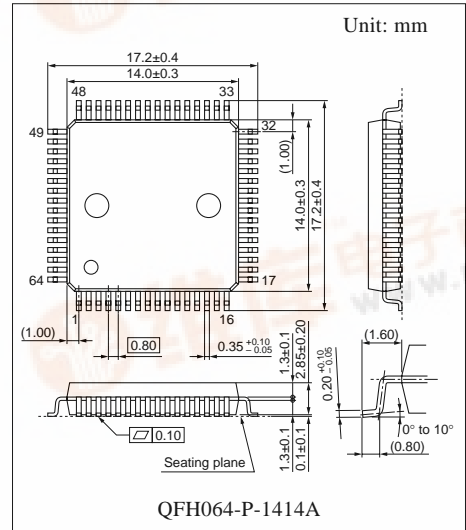

■ Block Diagram

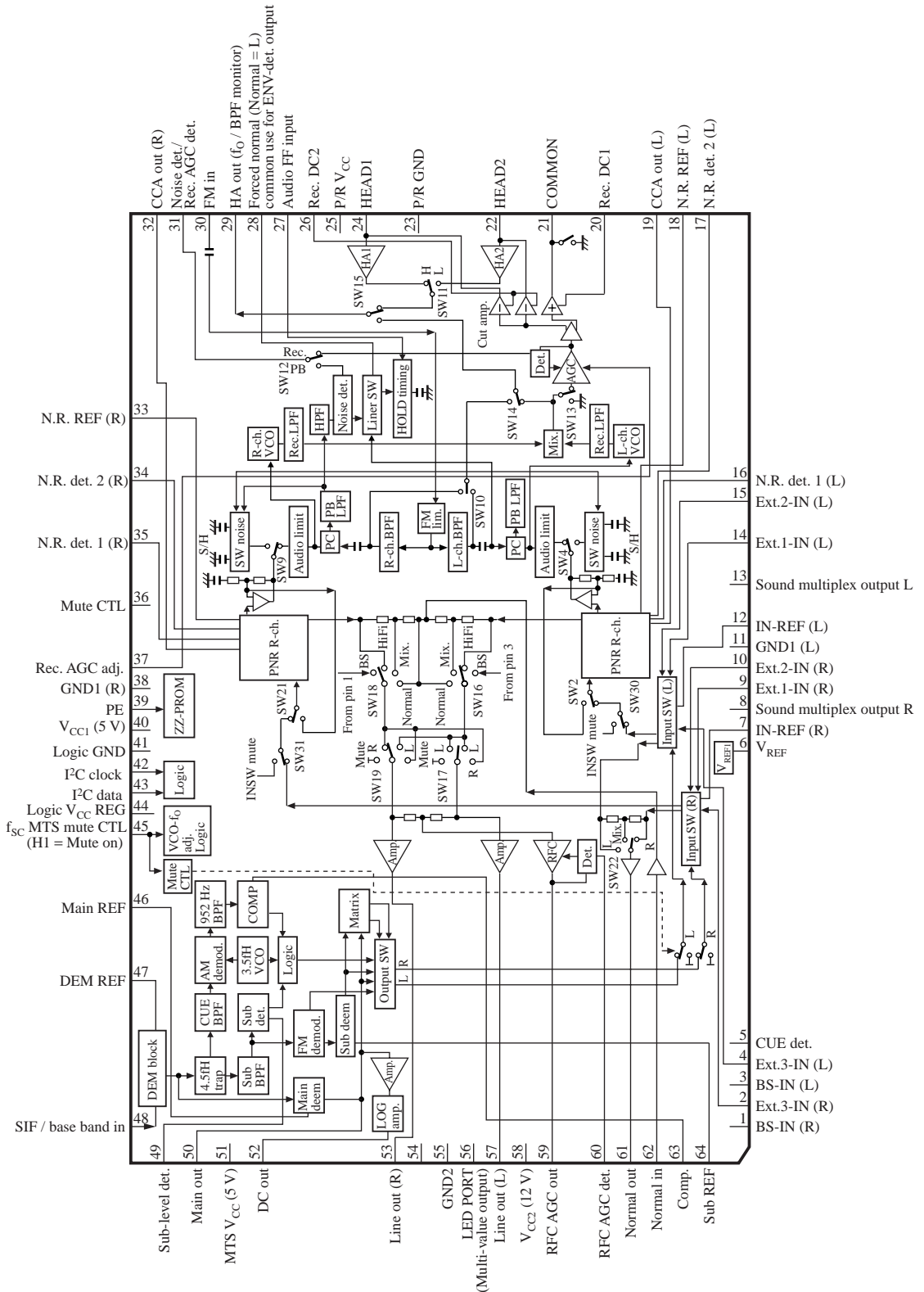

### ■ Pin Descriptions

Pin No.	Description	Pin No.	Description
1	BS-IN (R)	32	CCA out (R)
2	Ext.3-IN (R)	33	N.R. REF (R-channel)
3	BS-IN (L)	34	N.R. det. 2 (R-channel)
4	Ext.3-IN (L)	35	N.R. det. 1 (R-channel: Weighting)
5	CUE det.	36	Mute-CTL pin
6	$1/2 V_{CC1} - V_{REF}$	37	Rec.-AGC adj. pin
7	IN-REF (R)	38	GND1 (R)
8	Sound multiplex output R	39	PE pin
9	Ext.1-IN (R)	40	$V_{CC}$ ( $V_{CC1} = 5\text{ V}$ )
10	Ext.2-IN (R)	41	Logic-GND
11	GND1 (L)	42	Serial clock input
12	IN-REF (L)	43	Serial data input
13	Sound multiplex output L	44	Logic-REG pin
14	Ext.1-IN (L)	45	Reference signal input pin for $f_O$ automatic adjustment Sound multiplex mute-CTL pin
15	Ext.2-IN (L)		
16	N.R. det. 1 (L-channel: Weighting)		
17	N.R. det. 2 (L-channel)	46	Main REF
18	N.R. REF (L-channel)	47	DEM REF
19	CCA out (L)	48	SIF / base band input
20	(+) Rec. amp. DCFB pin	49	Sub level det.
21	(+) Rec. amp. output and PB common pin	50	Main out
22	(-) Rec. amp. output and PB-channel 2 input pin	51	MTS $V_{CC}$ (typ. = 5 V)
		52	DC out
23	Pre/rec.-GND	53	Line out (R-channel)
24	(-) Rec. amp. output and PB-channel 1 input pin	54	N.C.
		55	GND2
25	Pre/rec.- $V_{CC}$	56	LED PORT
26	(-) Recording amplifier DCFB pin	57	Line out (L-channel)
27	Head switching pulse input for FM audio	58	$V_{CC2}$ (typ. = 12 V)
28	Envelope detector and forced normal output	59	RFC out
29	Pre-amp. output / monitor output Rec.-mute CTL pin	60	RFC-AGC det.
		61	Normal out
30	Playback FM input	62	Normal in
31	Normal identification noise detection and rec.-AGC det. pin	63	Comp.
		64	Sub REF

### ■ Absolute Maximum Ratings

Parameter	Symbol	Rating	Unit
Supply voltage	$V_{CC1}$	5.5	V
	$V_{CC2}$	13.0	
Power dissipation <sup>*1,2</sup>	$P_D$	798	mW
Operating ambient temperature <sup>*1</sup>	$T_{opr}$	-20 to +75	°C
Storage temperature <sup>*1</sup>	$T_{stg}$	-55 to +150	°C

Note) 1. The reverse insertion of this IC will cause its breakdown.

2. Use this IC paying attention to its surge breakdown. (Refer to "■ Usage Note" in detail.)

3. \*1: Except for the power dissipation, operating ambient temperature and storage temperature, all ratings are for  $T_a = 25^\circ\text{C}$ .

\*2: The power dissipation shown is the value for  $T_a = 75^\circ\text{C}$ . (Refer to "■ Application Notes" in detail.)

### ■ Recommended Operating Range

Parameter	Symbol	Range	Unit
Supply voltage	$V_{CC1}$	4.5 to 5.3	V
	$V_{CC2}$	8.0 to 12.5	

### ■ Electrical Characteristics at $V_{CC1} = 5\text{ V}$ , $V_{CC2} = 12\text{ V}$ , $T_a = 25^\circ\text{C}$

Parameter	Symbol	Conditions	Min	Typ	Max	Unit
Circuit current (5 V) at recording	$I_{CCR1}$	Recording mode Measurement after adjusting $f_o$	104	130	156	mA
Circuit current (12 V) at recording	$I_{CCR2}$	Recording mode Measurement after adjusting $f_o$	5	9	13	mA
Circuit current (5 V) at playback	$I_{CCP1}$	Playback mode Measurement after adjusting $f_o$	70	95	120	mA
Circuit current (12 V) at playback	$I_{CCP2}$	Playback mode Measurement after adjusting $f_o$	5	9	13	mA
ENC out level 1-L	$VHRO_{1L}$	$V_{IN} = -26.8\text{ dBs}$ , 1 kHz, DIN audio	-11.5	-9.5	-7.5	dBs
ENC out level 1-R	$VHRO_{1R}$	$V_{IN} = -26.8\text{ dBs}$ , 1 kHz, DIN audio	-11.5	-9.5	-7.5	dBs
ENC out level 3-L	$VHRO_{3L}$	$V_{IN} = -86.8\text{ dBs}$ , 1 kHz DIN audio, $VHRO_{3L}/VHRO_{1L}$	-33	-30	-27	dB
ENC out level 3-R	$VHRO_{3R}$	$V_{IN} = -86.8\text{ dBs}$ , 1 kHz DIN audio, $VHRO_{3R}/VHRO_{1R}$	-33	-30	-27	dB
Normal recording out level	$VNRO$	$V_{IN} = -26.8\text{ dBs}$ , 1 kHz, Normal out	-21.5	-20.0	-18.5	dBs
Line out level L Gain = mode (0)	$VG2_L$	$V_{IN} = -26.8\text{ dBs}$ , 1 kHz Gain = High	-7.5	-6.0	-4.5	dBs
Line out level R Gain = mode (0)	$VG2_R$	$V_{IN} = -26.8\text{ dBs}$ , 1 kHz Gain = High	-7.5	-6.0	-4.5	dBs
Line out THD L	$THRM_L$	$V_{IN} = -26.8\text{ dBs}$ , 1 kHz	—	0.05	0.1	%
Line out THD R	$THRM_R$	$V_{IN} = -26.8\text{ dBs}$ , 1 kHz	—	0.05	0.1	%
Line out $V_{O-max}$ L	$VMLO_L$	$f_{IN} = 1\text{ kHz}$ , at output THD 3%	8.2	10.5	—	dBs
Line out $V_{O-max}$ R	$VMLO_R$	$f_{IN} = 1\text{ kHz}$ , at output THD 3%	8.2	10.5	—	dBs

**■ Electrical Characteristics at  $V_{CC1} = 5\text{ V}$ ,  $V_{CC2} = 12\text{ V}$ ,  $T_a = 25^\circ\text{C}$  (continued)**

Parameter	Symbol	Conditions	Min	Typ	Max	Unit
ENC out $V_{O\text{-max}}$ L	VMFE <sub>L</sub>	$f_{IN} = 1\text{ kHz}$ , at output THD 3%	-4	0.3	—	dBS
ENC out $V_{O\text{-max}}$ R	VMFE <sub>R</sub>	$f_{IN} = 1\text{ kHz}$ , at output THD 3%	-4	0.3	—	dBS
RF conv. out level	VRFC	$V_{IN} = -26.8\text{ dBBS}$ , 1 kHz BS monitor mode	-8	-5	-2	dBS
Line out S/N L	NHLO <sub>L</sub>	$R_G = 6.8\text{ k}\Omega$ , DIN audio	75	80	—	dB
Line out S/N R	NHLO <sub>R</sub>	$R_G = 6.8\text{ k}\Omega$ , DIN audio	75	80	—	dB
Crosstalk between inputs 1 *1 (Select the sound multiplex)	CT <sub>IT</sub>	Ext.1 ~ Ext.3 in = -16.8 dBBS 1 kHz, DIN audio	—	-60	-55	dB
Crosstalk between inputs 2 *1 (Ext.1-IN select)	CT <sub>IE1</sub>	Sound multiplex Ext.2 ~ Ext.3 in = -16.8 dBBS 1 kHz, DIN audio	—	-75	-65	dB
Crosstalk between inputs 3 *1 (Ext.2-IN select)	CT <sub>IE2</sub>	Sound multiplex Ext.1, Ext.3 in = -16.8 dBBS 1 kHz, DIN audio	—	-75	-65	dB
Crosstalk between inputs 4 *1 (Ext.3-IN select)	CT <sub>IE3</sub>	Sound multiplex Ext.1, Ext.2 in = -16.8 dBBS 1 kHz, DIN audio	—	-75	-65	dB
Crosstalk between channels R→L *1	CT <sub>TRL</sub>	Ext.1 in R-ch. = -16.8 dBBS, 1 kHz DIN audio	—	-80	-65	dB
Crosstalk between channels L→R *1	CT <sub>TLR</sub>	Ext.1 in L-ch. = -16.8 dBBS, 1 kHz DIN audio	—	-80	-65	dB
Crosstalk between output mode 1 *1 (Normal select)	CT <sub>HN</sub>	HiFi, BS in = -16.8 dBBS 1 kHz, DIN audio	—	-75	-60	dB
Crosstalk between output mode 2 *1 (HiFi select)	CT <sub>NH</sub>	HiFi, BS in = -16.8 dBBS 1 kHz, DIN audio	—	-75	-60	dB
Crosstalk between output mode 3 *1 (BS monitor mode)	CT <sub>NH</sub>	HiFi, NOR in = -16.8 dBBS 1 kHz, DIN audio	—	-60	-55	dB
Crosstalk between ENC out channels (R→L)	CT <sub>ENRL</sub>	Ext.1 in R-ch. = -16.8 dBBS, 1 kHz DIN audio	—	-40	-30	dB
Crosstalk between ENC out channels (L→R)	CT <sub>ENLR</sub>	Ext.1 in L-ch. = -16.8 dBBS, 1 kHz DIN audio	—	-40	-30	dB
Output muting ratio L *1	Mute <sub>L</sub>	TV in = -16.8 dBBS, 1 kHz, Gain = 1 DIN audio	—	-60	-45	dB
Output muting ratio R *1	Mute <sub>R</sub>	TV in = -16.8 dBBS, 1 kHz, Gain = 1 DIN audio	—	-60	-45	dB
VCO output frequency L (NTSC)	$f_{NL}$	NTSC mode, non-modulation, after adjustment	1 292	1 300	1 308	kHz
VCO output frequency R (NTSC)	$f_{NR}$	NTSC mode, non-modulation, after adjustment	1 692	1 700	1 708	kHz
VCO output L/R mix. ratio L	FNLN	NTSC mode, mode = (0, 1)	8.5	10	11.5	dB

Note) \*1: 10 dB should be reduced from the calculation result because of +10 dB increased input.

**■ Electrical Characteristics at  $V_{CC1} = 5\text{ V}$ ,  $V_{CC2} = 12\text{ V}$ ,  $T_a = 25^\circ\text{C}$  (continued)**

Parameter	Symbol	Conditions	Min	Typ	Max	Unit
FM deviation L	$DEV_L$	$V_{IN} = -26.8\text{ dBs}$ , 1 kHz	44	50	56	kHz
FM deviation R	$DEV_R$	$V_{IN} = -26.8\text{ dBs}$ , 1 kHz	44	50	56	kHz
FM deviation L/R ratio	$DEV_{LR}$	$DEV_R - DEV_L$	-6	0	6	kHz
FM modulation distortion L	$THFE_L$	$V_{IN} = -26.8\text{ dBs}$ , 1 kHz, FM RF out	—	0.5	1.0	%
FM modulation distortion R	$THFE_R$	$V_{IN} = -26.8\text{ dBs}$ , 1 kHz, FM RF out	—	0.5	1.0	%
FM modulation S/N L	$NHFE_L$	$R_G = 6.8\text{ k}\Omega$ , DIN audio, FM RF out	33	40	—	dB
FM modulation S/N R	$NHFE_R$	$R_G = 6.8\text{ k}\Omega$ , DIN audio, FM RF out	33	40	—	dB
1.3 MHz BPF frequency characteristics 1 *2	BPF11	BPF monitor (L-ch.), $f_C = 1.3\text{ MHz}$	70	140	210	mV[p-p]
1.3 MHz BPF frequency characteristics 2 *2	BPF12	$f_C = 1.45\text{ MHz}$	-10.0	-5.0	2.0	dB
1.3 MHz BPF frequency characteristics 3 *2	BPF13	$f_C = 1.15\text{ MHz}$	-4.0	-0.5	3.0	dB
1.3 MHz BPF frequency characteristics 5 *2	BPF15	$V_{(1.05M)} / V_{(1.45M)}$	-13	-1.5	7.0	dB
1.7 MHz BPF frequency characteristics 1 *2	BPF21	BPF monitor (R-ch.), NTSC mode $f_C = 1.7\text{ MHz}$	70	140	210	mV[p-p]
1.7 MHz BPF frequency characteristics 2 *2	BPF22	$f_C = 1.85\text{ MHz}$	-6.0	0	3.5	dB
1.7 MHz BPF frequency characteristics 3 *2	BPF23	$f_C = 1.55\text{ MHz}$	-7.0	-1.6	3.0	dB
PB out level 1-L *2	$VHPO_{1L}$	$V_{IN} = 50\text{ kHz Dev.}$ , 1 kHz, Line out	-7.5	-6.0	-4.5	dBS
PB out level 1-R *2	$VHPO_{1R}$	$V_{IN} = 50\text{ kHz Dev.}$ , 1 kHz, Line out	-7.5	-6.0	-4.5	dBS
PB out level L/R ratio	BHP		-1.5	0	1.5	dB
PB out level 3-L *2	$VHPO_{3L}$	$FM_{IN} = 50\text{ kHz}$ -30 dB, DIN audio	-66	-60	-54	dB
PB out level 3-R *2	$VHPO_{3R}$	$FM_{IN} = 50\text{ kHz}$ -30 dB, DIN audio	-66	-60	-54	dB
PB out S/N L *2	$NHPO_L$	Non-modulation, Line out, DIN audio	75	80	—	dB
PB out S/N R *2	$NHPO_R$	Non-modulation, Line out, DIN audio	75	80	—	dB
PB out distortion L *2	$THPO_L$	In: Dev = 100 kHz, $f = 1\text{ kHz}$ Line out	—	0.2	0.8	%
PB out distortion R *2	$THPO_R$	In: Dev = 100 kHz, $f = 1\text{ kHz}$ Line out	—	0.2	0.8	%
Crosstalk between PB out channels (R→L) *2	$CTP_{RL}$	$V_{IN} = 50\text{ kHz Dev.}$ , 1 kHz DIN audio	—	-80	-65	dB
Crosstalk between PB out channels (L→R) *2	$CTP_{LR}$	$V_{IN} = 50\text{ kHz Dev.}$ , 1 kHz DIN audio	—	-80	-65	dB
DOC on level	DOC1	$f_{CL} = 1.3\text{ MHz}$ $f_{CR} = 1.7\text{ MHz} \pm 50\text{ kHz Dev.}$	7	15	30	mV[p-p]
DOC hysteresis	DOC2	$f_{CL} = 1.3\text{ MHz}$ $f_{CR} = 1.7\text{ MHz} \pm 50\text{ kHz Dev.}$	0.1	1.5	6.0	dB

Note) \*2: PB-FM input level: Single 140 mV[p-p], Mix. 280 mV[p-p]

**■ Electrical Characteristics at  $V_{CC1} = 5\text{ V}$ ,  $V_{CC2} = 12\text{ V}$ ,  $T_a = 25^\circ\text{C}$  (continued)**

Parameter	Symbol	Conditions	Min	Typ	Max	Unit
Forced normal on level 1 *2	ND1	$f = 150\text{ kHz}$ , ND mode = 0, 0	30	75	120	kHz Dev
PB-ch.1 gain	$G_{2429}$	$f = 1.5\text{ MHz}$ , $0.2\text{ mV[p-p]}$ , AFF = High	70	76	82	dB
PB-ch.2 gain	$G_{2229}$	$f = 1.5\text{ MHz}$ , $0.2\text{ mV[p-p]}$ , AFF = Low	70	76	82	dB
Gain ratio between PB-channels	$G_{2422}$	Calculates the $G_{2429} - G_{2229}$	-3	0	3	dB
PB-ch.1 input referred noise	$N_{2429}$	Divide by gain after measuring noise level with 1 MHz BPF	—	0.7	1.2	$\mu\text{V[rms]}$
PB-ch.2 input referred noise	$N_{2229}$	Divide by gain after measuring noise level with 1 MHz BPF	—	0.7	1.2	$\mu\text{V[rms]}$
Rec. output level (1.3 MHz component)	$I_{24L}$	Measure the 1.3 MHz component of current output, ( $R_{adj} = 33\text{k}$ ), NOR	6	9	12	$\text{mA[p-p]}$
Rec. output level (1.7 MHz component)	$I_{24R}$	Measure the 1.7 MHz component of current output, ( $R_{adj} = 33\text{k}$ ), NOR	21	27	33	$\text{mA[p-p]}$
Rec. output 2nd harmonic distortion (2.6 MHz/1.3 MHz component ratio)	$I_{2fL}$	Measure the 2.6 MHz/1.3 MHz component of current output	—	-40	-35	dB
Rec. output 2nd harmonic distortion (3.4 MHz/1.7 MHz component ratio)	$I_{2fR}$	Measure the 3.4 MHz/1.3 MHz component of current output	—	-40	-35	dB

**Television sound multiplex demodulation block**

Note) Input level at 100% modulation Mono, L+R:  $106\text{ mV[rms]}$  (=  $0.3\text{ V[p-p]}$ )

Sub (L-R) carrier:  $63.6\text{ mV[rms]}$  (BIL),  $84.8\text{ mV[rms]}$  (Stereo)

Unless otherwise specified, pre-emphasis = off

Mono output level	$V0(\text{Mon})$	$f = 1\text{ kHz}$ , Mono, 100% modulation, 15 kHz LPF	-5.7	-3.7	-1.7	dBS
Mono frequency characteristics (10 kHz)	$V1(\text{Mon})$	$f = 1\text{ kHz}$ , Mono, 100% modulation, 15 kHz LPF	-18	-14	-10	dB
Mono distortion	THD(Mon)	$f = 1\text{ kHz}$ , Mono, 100% modulation, 15 kHz LPF	—	0.3	1	%
Mono S/N	S/N(Mon)	Non-signal, 15 kHz LPF	60	67	—	dB
Channel balance	CB(Mon)	$f = 1\text{ kHz}$ , Mono, 100% modulation, 15 kHz LPF	-1	0	1	dB
Sub output level	$V0(\text{Sub})$	$f = 1\text{ kHz}$ , BIL, 100% modulation, 15 kHz LPF	-5.7	-3.7	-1.7	dBS
Sub frequency characteristics (10 kHz)	$V1(\text{Sub})$	$f = 1\text{ kHz}$ , BIL, 100% modulation, 15 kHz LPF	-20	-16	-12	dB
Sub distortion	THD(Sub)	$f = 1\text{ kHz}$ , BIL, 100% modulation, 15 kHz LPF	—	1	2	%
Sub S/N	S/N(Sub)	Sub carrier + Cue (BIL), 15 kHz LPF	54	60	—	dB
Sub detection sensitivity	SD	Sub carrier + Cue (BIL)	-9	-4.3	-3	dB
Stereo output level	$V1(\text{st})$	$f = 1\text{ kHz}$ , Stereo, 100% modulation, 15 kHz LPF	-5.7	-3.7	-1.7	dBS

Note) \*2: PB-FM input level: Single  $140\text{ mV[p-p]}$ , Mix.  $280\text{ mV[p-p]}$  (30-pin)

**■ Electrical Characteristics at  $V_{CC1} = 5\text{ V}$ ,  $V_{CC2} = 12\text{ V}$ ,  $T_a = 25^\circ\text{C}$  (continued)**

Parameter	Symbol	Conditions	Min	Typ	Max	Unit
Television sound multiplex demodulation block (continued)						
Stereo separation 1	Sepr	$f = 1\text{ kHz}$ (L-only), 100% modulation, 15 kHz LPF	30	43	—	dB
Stereo separation 2	Sepl	$f = 1\text{ kHz}$ (R-only), 100% modulation, 15 kHz LPF	30	43	—	dB
Stereo distortion	THD(st)	$f = 1\text{ kHz}$ (Stereo), 100% modulation	—	0.3	2	%
Stereo S/N	$V_{N(st)}$	Sub carrier + Cue (Stereo) 15 kHz LPF	54	60	—	dB
CUE detection sensitivity	CD	Sub carrier + Cue (BIL)	-11	-6.6	-4	dB
Crosstalk (Main→Sub)	$CT_{MS}$	$f = 1\text{ kHz}$ (BIL main), 100% modulation, 15 kHz LPF	54	60	—	dB
Crosstalk (Sub→Main)	$CT_{SM}$	$f = 1\text{ kHz}$ (BIL sub), 100% modulation, 15 kHz LPF	54	60	—	dB
Residual carrier (Main)	$L_{CM}$	$f = 1\text{ kHz}$ (BIL), 100% modulation	—	10	20	mV[rms]
Residual carrier (Sub)	$L_{CS}$	$f = 1\text{ kHz}$ (BIL), 100% modulation	—	15	30	mV[rms]
DC offset (Monaural)	$O_{MO}$	Non-signal	—	20	100	mV
DC offset (Stereo)	$O_{ST}$	Sub carrier signal, + Cue signal (Stereo)	—	20	100	mV
DC offset (Main)	$O_{MA}$	Sub carrier signal + Cue signal (BIL) Main	—	20	100	mV
DC offset (Sub)	$O_{SB}$	Sub carrier signal + Cue signal (BIL) Sub	—	20	100	mV
Mute attenuation amount (Monaural)	$M_{MO}$	$f = 1\text{ kHz}$ (Mono), 100% modulation	65	80	—	dB
Mute attenuation amount (Stereo)	$M_{ST}$	$f = 1\text{ kHz}$ (Stereo), 100% modulation	65	80	—	dB
Mute attenuation amount (Main)	$M_{MA}$	$f = 1\text{ kHz}$ (BIL), 100% modulation	65	80	—	dB
Mute attenuation amount (Sub)	$M_{SB}$	$f = 1\text{ kHz}$ (BIL), 100% modulation	65	80	—	dB
LED-PORT voltage 1 (Mono)	$LED_1$	Non-signal	0	0.1	0.4	V
LED-PORT voltage 2 (Stereo)	$LED_2$	Sub carrier signal, + Cue signal (Stereo)	1.3	1.6	1.9	V
LED-PORT voltage 3 (BIL)	$LED_3$	Sub carrier signal, + Cue signal (BIL)	2.7	3.1	4	V
LOG amp. output 1	$V_{LOG1}$	$f = 440\text{ Hz}$ (Mono), 40% modulation	4	—	—	V
LOG amp. output 2	$V_{LOG2}$	$f = 440\text{ Hz}$ (Mono), 10% modulation	—	—	1	V
SIF detection block						
Output ratio of SIF to base band	VOSIF	$V_i$ (SIF) = 90 dB $\mu$ V, $f_m = 1\text{ kHz}$ Mono, 100% modulation, ratio to $V_O$ of base band	-0.5	0	0.5	dB
SIF total harmonic distortion	THDSIF	$V_i$ (SIF) = 90 dB $\mu$ V, $f_m = 1\text{ kHz}$ , 100% modulation	—	0.3	1.0	%



**■ Electrical Characteristics at  $V_{CC1} = 5\text{ V}$ ,  $V_{CC2} = 12\text{ V}$ ,  $T_a = 25^\circ\text{C}$  (continued)**
**• Design reference data**

Note) The characteristics listed below are theoretical values based on the IC design and are not guaranteed.

Parameter	Symbol	Conditions	Min	Typ	Max	Unit
Data input (high-level)	$V_{HDATA}$	At $V_{CC} = 5\text{ V}$	2.25	—	5	V
Data input (low-level)	$V_{LDATA}$	At $V_{CC} = 5\text{ V}$	0	—	0.75	V
Clock input (high-level)	$V_{HCLOC}$	At $V_{CC} = 5\text{ V}$	2.25	—	5	V
Clock input (low-level)	$V_{LCLOC}$	At $V_{CC} = 5\text{ V}$	0	—	0.75	V
Mute CTL input (high-level)	$V_{IHMUT}$	Mute on	3.5	—	5	V
Mute CTL input (low-level)	$V_{ILMUT}$	Mute off	0	—	1.5	V
Forced normal on level 2	ND2	$f = 150\text{ kHz}$ , Mode 01 Dev.	—	60	—	kHz Dev
RF conv. AGC level	VRFCAG	$V_{IN} = -16.8\text{ dBFS}$ , $f = 1\text{ kHz}$	—	1.0	—	dBFS
Normal rec. THD	TNRO	$V_{IN} = -26.8\text{ dBFS}$ , $f = 1\text{ kHz}$	—	0.02	—	%
Normal input crosstalk 1 (Line in R select)	$CTN_{RR}$	Ext.1 in L = $-16.8\text{ dBFS}$ DIN audio	—	-75	—	dB
Normal input crosstalk 2 (Line in L select)	$CTN_{LL}$	Ext.1 in R = $-16.8\text{ dBFS}$ DIN audio	—	-75	—	dB
Carrier 3rd harmonics L	$3HD_L$	RF recording out	—	-50	—	dB
Carrier 3rd harmonics R	$3HD_R$	RF recording out	—	-50	—	dB
1.3 MHz BPF frequency characteristics 4	BPF14	1.7 MHz / 1.3 MHz	—	-32	—	dB
1.3 MHz BPF frequency characteristics 6	BPF16	1.55 MHz / 1.15 MHz	—	-15	—	dB
1.7 MHz BPF frequency characteristics 4	BPF24	2.1 MHz / 1.7 MHz	—	-13	—	dB
1.7 MHz BPF frequency characteristics 5	BPF25	1.3 MHz / 1.7 MHz	—	-26	—	dB
1.7 MHz BPF frequency characteristics 6	BPF26	1.45 MHz / 1385 MHz	—	-8	—	dB
BPF group delay difference ( $f_0 \pm 100\text{ kHz}$ )	GDBPF	Difference of $f_0 \pm 100\text{ kHz}$	—	500	—	ns
VCO $f_0$ temperature dependency	TVCO	$f_0(T = -10^\circ\text{C}) - f_0(T = 75^\circ\text{C})$	—	5	—	kHz
Normal off delay time	MON	Define with FF timing	—	3	—	FF
ENC attack time	ENAT	$f = 5\text{ kHz}$ , $V_{IN} = \text{typ.} -20\text{ dB}$	—	4	—	ms
ENC recovery time	ENRT	$f = 5\text{ kHz}$ , $V_{IN} = \text{typ.} -20\text{ dB}$	—	65	—	ms
HOLD pulse width	HPUL	Test mode, PB	—	10	—	$\mu\text{s}$
ENV out 1	ENV1	1.3 MHz + 1.7 MHz mix. $70\text{ mV[p-p]} \times 2$	—	1.3	—	V
ENV out 2	ENV2	1.3 MHz + 1.7 MHz mix. $280\text{ mV[p-p]} \times 2$	—	2.2	—	V
HiFi rec. → PB crosstalk	CTRP	PB, $V_{IN} = -16.8\text{ dBFS}$ , 1 kHz	—	-79	—	dB

■ Terminal Equivalent Circuits (continued)

Pin No.	Equivalent circuit	Description	Voltage (typ.)
1		<p>BS-IN (R-channel): BS monitor-exclusive input pin Typical input level is 1 kHz, -26.8 dBS.</p>	2.5 V
2		<p>Ext.3-IN (R-channel): Typical input level is 1 kHz, -26.8 dBS.</p>	0 V
3	Refer to pin 1	BS-IN (L-channel)	2.5 V
4	Refer to pin 2	Ext.3-IN (L-channel)	0 V
5		Cancel of DC offset for Cue signal	2.5 V
6		$V_{REF}$	2.5 V

■ Terminal Equivalent Circuits (continued)

Pin No.	Equivalent circuit	Description	Voltage (typ.)
7		IN-REF (R-channel):	2.05 V
8		Sound multiplex output R: Tuner output pin	2.5 V
9	Refer to pin 2	Ext.1-IN (R-channel)	0 V
10	Refer to pin 2	Ext.2-IN (R-channel)	0 V
11	—	GND1 (L-channel)	0 V
12	Refer to pin 7	IN-REF (L-channel)	2.03 V
13	Refer to pin 8	Sound multiplex output L	2.5 V
14	Refer to pin 2	Ext.1-IN (L-channel)	0 V
15	Refer to pin 2	Ext.2-IN (L-channel)	0 V
16		N.R. det. 1 (L-channel): Pin for connection of weighting filter externally attached.	2.5 V
17		N.R. det. 2 (L-channel)	At non-signal: 0.4 V  At typical input: 0.7 V

■ Terminal Equivalent Circuits (continued)

Pin No.	Equivalent circuit	Description	Voltage (typ.)
18		N.R. REF (L-channel)	2.5 V
19	Refer to pin 32	CCA out (L-channel)	2.5 V
20		Rec. DC1: Pin for DC feedback of rec. (+) amp.	2.5 V (Rec.)
21		COMMON: Output pin of rec. (+) amp. at recording. Termination SW pin of COMMON at playback.	2.5 V (Rec.)  0 V (PB)

### ■ Terminal Equivalent Circuits (continued)

Pin No.	Equivalent circuit	Description	Voltage (typ.)
22	<p>Pin25 (P/R <math>V_{CC}</math>)</p>	<p>P/R term 1: Output pin of rec. (-) amp. at recording. Head amp. input pin at playback.</p>	<p>2.5 V (Rec.) 0.7 V (PB)</p>
23	—	P/R GND	0 V
24	Refer to pin 22	P/R term 2	At rec.: 2.5 V At PB: 0.7 V
25	—	P/R $V_{CC}$	5 V
26	Refer to pin 20	Rec. DC2: Pin for DC feedback of rec. (-) amp.	2.5 V
27	<p>Pin40 (<math>V_{CC1}</math>) Pin25</p>	<p>Audio FF: High: 3.5 V to 5 V Low: 0 V to 1.5 V</p>	
28	<p>Pin40 (<math>V_{CC1}</math>)</p>	<p>ENV-det.: 3.7 V or more at rec. <math>f_0</math> adj. completion</p>	—
29	<p>Pin40 (<math>V_{CC1}</math>)</p>	<p>HA out: Common use for rec.-mute control pin</p>	1.8 V
30		FM in	0 V

■ Terminal Equivalent Circuits (continued)

Pin No.	Equivalent circuit	Description	Voltage (typ.)
31		Noise det. : At playback: N-det. At recording: Rec. AGC-det.	—
32		CCA out (R-channel): Pin for connection of N.R.-emph. capacitor externally attached.	0 V
33	Refer to pin 18	N.R. REF (R-channel)	2.5 V
34	Refer to pin 17	N.R. det. 2 (R-channel)	At non-signal: 0.4 V At typical input: 0.7 V
35	Refer to pin 16	N.R. det. 1 (R-channel)	2.5 V
36		Mute CTL: Mute-on: 5 V Mute-off: 0 V or open	0 V
37		Rec. AGC adj.	1.7 V
38		GND1 (R-channel)	0 V

■ Terminal Equivalent Circuits (continued)

Pin No.	Equivalent circuit	Description	Voltage (typ.)
39		PE	—
40		V <sub>CC1</sub>	5 V
41		Logic GND	0 V
42	<p>Pin40 (V<sub>CC1</sub>)</p>	Clock: High: 2 V to 5 V Low: 0 V to 1 V	
43	<p>Pin40 (V<sub>CC1</sub>)</p>	Data: High: 2 V to 5 V Low: 0 V to 1 V	
44	<p>Pin40 (V<sub>CC1</sub>)</p>	Logic V <sub>CC</sub> REG	3.3 V
45	<p>Pin40 (V<sub>CC1</sub>)</p>	f <sub>sc</sub>	0 V
46	Refer to pin 64	Main REF	2.5 V

■ Terminal Equivalent Circuits (continued)

Pin No.	Equivalent circuit	Description	Voltage (typ.)
47		DEM REF	2.5 V
48		SIF / base band input	2.2 V
49		Sub level det.	2.5 V
50		Main out	2.5 V
51	—	MTS V <sub>CC</sub>	5 V
52		DC out	2.5 V



■ Terminal Equivalent Circuits (continued)

Pin No.	Equivalent circuit	Description	Voltage (typ.)
53		<p>Line out (R-channel): Typical output level can be changed by serial setting.</p>	6 V
54	—	N.C.	—
55	—	GND2	0 V
56		LED PORT	0 V
57	Refer to pin 53	Line out (L-channel)	6 V
58	—	$V_{CC2}$	12 V
59		<p>RFC AGC out: Typical output level can be changed by serial setting.</p>	6 V
60		RFC AGC det.	Non fixed

■ Terminal Equivalent Circuits (continued)

Pin No.	Equivalent circuit	Description	Voltage (typ.)
61	<p>Pin40 (<math>V_{CC1}</math>)</p> <p>850 <math>\Omega</math></p>	<p>Normal out:                      Typical output level                      1 kHz, -20 dBs</p>	2.5 V
62	<p>Pin40 (<math>V_{CC1}</math>)</p> <p>200 <math>\Omega</math></p> <p>300 k<math>\Omega</math></p> <p><math>V_{REF}</math></p>	<p>Normal in:                      Typical output level                      1 kHz, -20 dBs</p>	2.5 V
63	<p>Pin51 (MTS <math>V_{CC}</math>)</p> <p>600 <math>\Omega</math></p> <p>600 <math>\Omega</math></p> <p>5.1 k<math>\Omega</math></p>	Comp.	2.5 V
64	<p>600 <math>\Omega</math></p> <p>600 <math>\Omega</math></p> <p>20 k<math>\Omega</math> 20 k<math>\Omega</math></p> <p>10.2 k<math>\Omega</math></p>	Sub REF	2.5 V

■ Usage Note

When use this IC, note the following points.

- Use paying attention to surge breakdown of this IC. (C = 200 pF, R = 0 Ω)

Surge breakdown voltage	Corresponding pins
±140 V to ±200 V	1, 3, 6, 17, 18, 20, 21 22, 24, 25, 33, 36, 53, 57
±200 V or more	Except for above listed pins

■ Application Notes

1.  $P_D - T_a$  curves of QFH064-P-1414A

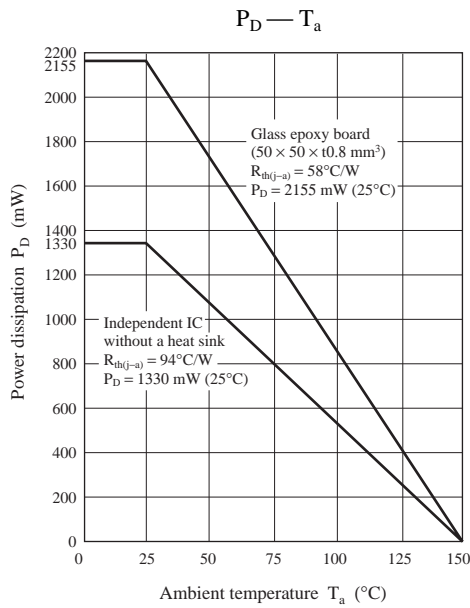

2. Rec. amp. output's dependence on resistance (Pin 37)

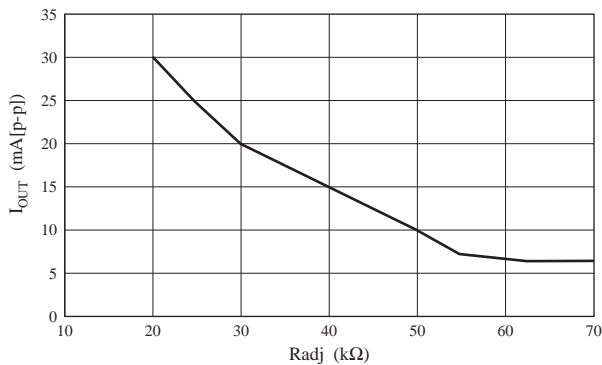

## ■ Application Notes (continued)

### 3. I<sup>2</sup>C bus of this IC

#### 1) Serial control timing specification

##### (1) Start and stop conditions

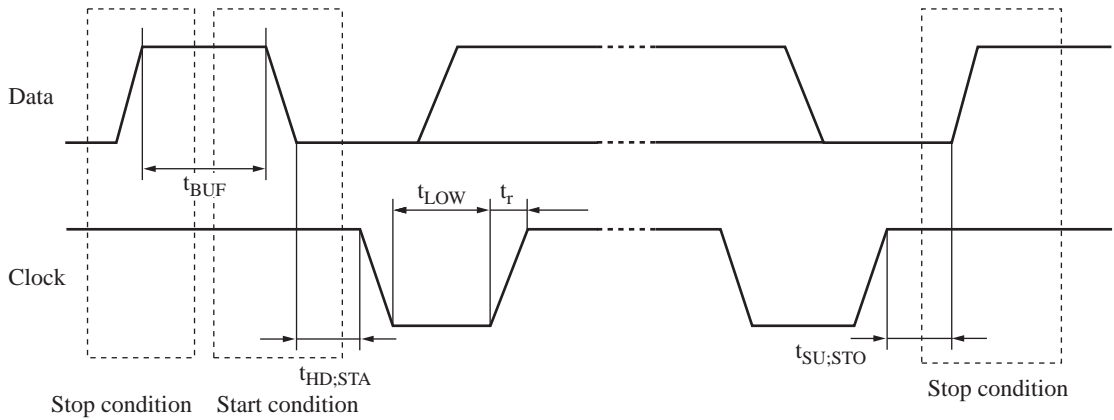

##### (2) Data recognition condition

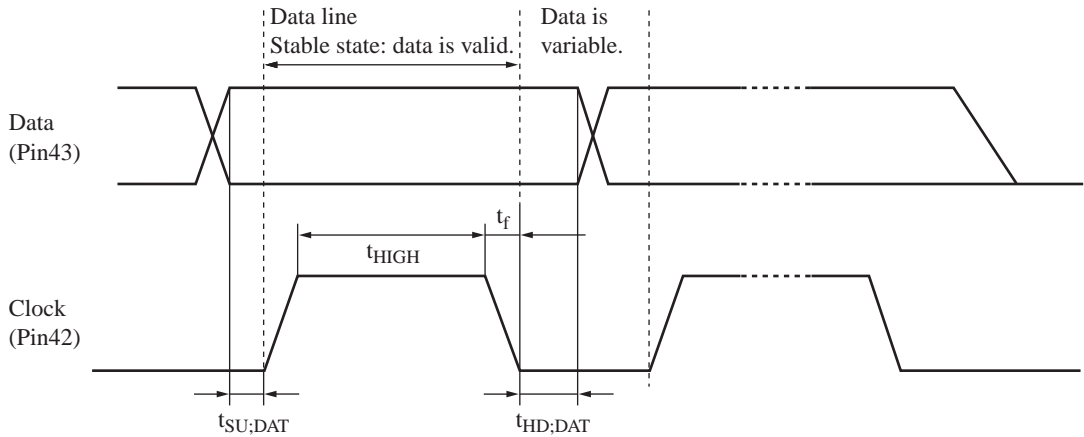

##### (3) Recommended operation condition

Parameter	Symbol	Min	Max	Unit
Bus free time between stop and start conditions	$t_{\text{BUF}}$	4.7	—	$\mu\text{s}$
Hold time start condition (The first clock pulse is generated after this period.)	$t_{\text{HD:STA}}$	4.0	—	$\mu\text{s}$
Low state hold time of clock	$t_{\text{LOW}}$	4.7	—	$\mu\text{s}$
Rise time of data and clock signal	$t_{\text{r}}$	—	1 000	ns
Setup time of stop condition	$t_{\text{SU:STO}}$	4.0	—	$\mu\text{s}$
Data setup time	$t_{\text{SU:DAT}}$	250	—	ns
High state hold time of clock	$t_{\text{HIGH}}$	4.0	—	$\mu\text{s}$
Fall time of data and clock signal	$t_{\text{f}}$	—	300	ns
Data hold time	$t_{\text{HD:DAT}}$	5.0	—	$\mu\text{s}$
Clock frequency	$f_{\text{SCL}}$	0	100	kHz

■ Application Notes (continued)

3. I<sup>2</sup>C bus of this IC (continued)

2) Data specification

(1) Slave address: 1 1 1 0 1 0 1 0

(2) Slave address format

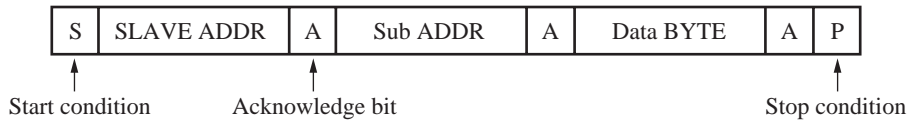

(3) Sub-address byte and data byte format: The underlined figures stand for the initial state.

AN3672FBP Serial mode								
Sub address	D7	D6	D5	D4	D3	D2	D1	D0
(HEX) 00	Rec. / PB 0 = PB 1 = Rec.	/	/	/	HiFi input select 0, 0 = Sound multiplex 0, 1 = Ext.1 1, 0 = Ext.2 1, 1 = Ext.3		NOR input select 0, 0 = xxxx 0, 1 = R-ch. 1, 0 = L-ch. 1, 1 = R/L-mix.	
01		Line out gain 0 = -6.0 dBs 1 = -7.5 dBs	Nor detection 0, 0 = High 0, 1 = MID 1, 0 = Low 1, 1 = Off		Output mode select 0, 0 = HiFi 0, 1 = Mix. 1, 0 = NOR 1, 1 = BS mon		Output channel select 0, 0 = Stereo 0, 1 = L-ch. 1, 0 = R-ch. 1, 1 = xxxx	
02	/	Rec. FM mix. ratio 0, 0 = 11 dB 0, 1 = 10 dB 1, 0 = 9 dB 1, 1 = 8 dB		/	DOC select 0 = On 1 = Off	ENV select 0 = ENV (linear) 1 = FORCE NOR (0/5 V)	V <sub>CC2</sub> select 0 = 9 V 1 = 12 V	
03	/	Power save 0 = Off 1 = On	Rec. mode 0, 0 = NOR (0 dB) 0, 1 = S-VHS (-2 dB) 1, 0 = Over rec. (2 dB) 1, 1 = xxxx		/	/	/	HSW polarity 0 = Normal 1 = Reverse
04	/							
05	/							
06	ZAP-mode 0 = DAC 1 = PROM	f <sub>O</sub> -adj. start 0 = Off 1 = On	f <sub>SC</sub> -SEL 0, 0 = 3.58 MHz 0, 1 = 4.43 MHz 1, 0 = 7.16 MHz 1, 1 = 8.86 MHz		f <sub>O</sub> -check 0 = Off 1 = On	0 fixed	INSW-mute 0 = Off 1 = On	/
07	f <sub>O</sub> monitor 0 = Off 1 = On	HOLD-TEST 0 = Off 1 = On	ENC/sound multiplex test 0, 0 = Off 0, 1 = Sound multiplex 1, 0 = ENC 1, 1 = Off		FM-test 0 = Off 1 = On	/	/	/
08	/							
09	/							
A	/							
B	TEST1 0 = Off 1 = On	/	Adj 0 = Off 1 = On	Bilingual mode CTL 0, 0 = BOTH 1, 0 = Sub 0, 1 = Main 1, 1 = xxxx		Forced MON 0 = Off 1 = On	Sound mute 0 = Off 1 = On	Input select 0 = 4.5 MHz 1 = Base band

■ Application Notes (continued)

3. I<sup>2</sup>C bus of this IC (continued)

3) Auto increment function

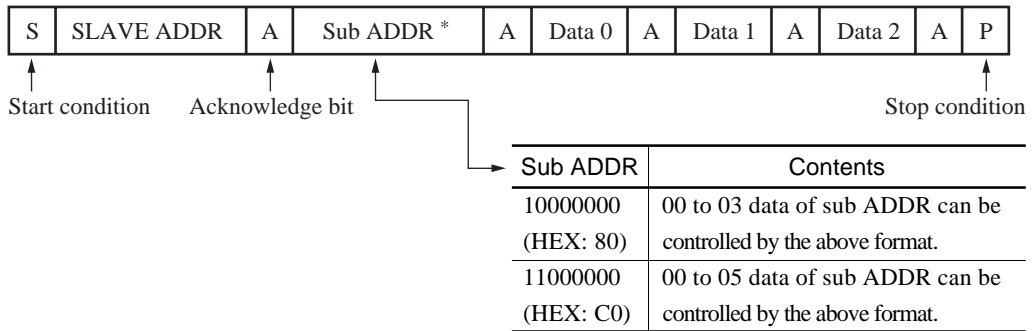

Once the data is inputted as shown above, the specified sub-address data is set to Data 0, one increment data to Data 1, further one increment data to Data 2. In this way, the plural data can be controlled at one time.

4) VCO f<sub>O</sub> auto adjusting manual

1. Power on
2. Setting 1 (IN SW mute = On)  
IC mode setting: Rec. (\*0 D7 = 1)  
Power save = Off (\*3 Except for D6 and D7 = 1)  
IN SW Mute Serial \*6 D1 0→1 Ex. \*6 0 0 0 0 0 1 0

Wait  
1.5 s or more

3. Setting 2 (Selection of f<sub>SC</sub> frequency to be used.)

Sub-address *6		f <sub>SC</sub> frequency
D5	D4	
0	0	3.58 MHz
0	1	4.43 MHz
1	0	7.16 MHz
1	1	8.86 MHz

Ex. When you use f<sub>SC</sub> = 7.16 MHz,  
\*6 0 0 1 0 0 0 1 0  
          ↑↑          ↑  
          f<sub>SC</sub> select  
                          IN SW mute continues

Wait  
0.1 s or more

4. Adjustment start (f<sub>O</sub> adj. start = On)

Serial \*6 D6 0→1

Ex. f<sub>O</sub> adj. start  
          ↓  
\*6 0 1 1 0 0 0 1 0  
          ↑↑          ↑  
          Setting hitherto continues

Max.  
within 0.5 s

5. Adjustment completion

ENV det. output (pin 28) potential  
Informs of completion with low to high

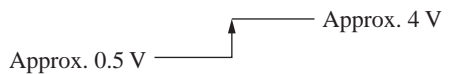

6. Setting cancellation

f<sub>O</sub> adj. start = Off Serial \*6 D6 1 → 0  
IN SW mute. = Off Serial \*6 D1 1 → 0

7. Transmission of normal data

Note) Input level of f<sub>SC</sub> is 100 mV[p-p] to 500 mV[p-p].

### ■ Application Notes (continued)

#### 3. I<sup>2</sup>C bus of this IC (continued)

##### 5) Serial mode of sound multiplex

Broadcasting signal	Serial setting Sub address (B)			Line out			LED-PORT (Pin 56)
	D4	D3	D2	L-ch.	R-ch.	Contents	
	Bilingual CTL		Forced monaural				
Bilingual	0	0	0	Main	Sub	Both	min. 2.7 V to (typ. 3.1 V)
	0	1	0	Main	Main	Main	
	1	0	0	Sub	Sub	Sub	
	*	*	1	Main	Main	Mono	
Stereo	*	*	0	L	R	Stereo	min. 1.3 V to max. 1.9 V (typ. 1.6 V)
	*	*	1	L + R	L + R	Mono	
Mono	*	*	*	L + R	L + R	Mono	max. 0.4 V (typ. 0.1 V)

##### 6) Precautions on MTS application circuit

- (1) When an external input is selected with large amplitude noise into an input pin of television sound multiplex block, an appropriate signal to noise ratio is not always guaranteed. On use of SIF input, you can counter this problem by switching the setting from SIF to base band input through a serial control when using an external input. In this time, however, a timing control is required to return it to SIF in advance so as not to cause any shock noise which is likely to come out when HiFi input selector returns to television sound multiplex side. On use of a base band input, it is recommended that you perform muting outside to prevent from noise being inputted into television sound multiplex.
- (2) On use of television sound multiplex with a base band input, if you adjust an input level for 106 mV[rms] (= 300 mV[p-p]) with mono 100% modulation pre-emphasis off, the IC is in a state of an optimum separation. When you can not obtain an appropriate separation due to deviation of input signal frequency characteristics, however, you can adjust separation by fitting a volume of 100 k $\Omega$  between pin 47 and GND. As the IC is already adjusted for an optimum separation with the above reference input, you can substitute the input level adjusting volume for a separation adjustment. In this case, do not forget to set pin 47 to open.
- (3) On use of sound multiplex with SIF input, an SIF input level from a tuner be set to 90 dB $\mu$ V  $\pm$ 10 dB $\mu$ V against a typical RF electric field input.  
To get an appropriate separation without adjustment, you are required to use the flattest possible SIF-BPF band width that does not cause any delay time difference between main and sub in the range of 4.5 MHz  $\pm$ 42 kHz. Likewise, use the gain band width which is broad enough not to attenuate cue signal carrier where a main component of 4.5 MHz  $\pm$ 55 kHz.
- (4) In the tuner characteristics, a demodulation linearity must be set to 250% or more modulation to prevent the sub-carrier signal from being damaged by over-modulation of pre-emphasis in a higher band width.
- (5) The stereo modulator must be used with good characteristics and well-calibrated equipment at measurement of separation. When using SIF input, FM modulation factor must be tuned exactly so as to be  $\pm$ 25 kHz at mono 100% modulation and pre-emphasis off. At the same time, measurement must be done by using the LPF which can attenuate 20 dB or more at 30 kHz between line-out and AC level-meter.

■ Application Notes (continued)

3. I<sup>2</sup>C bus of this IC (continued)

6) Precaution on MTS application circuit (continued)

(6) The case without adjustment (SIF mode)

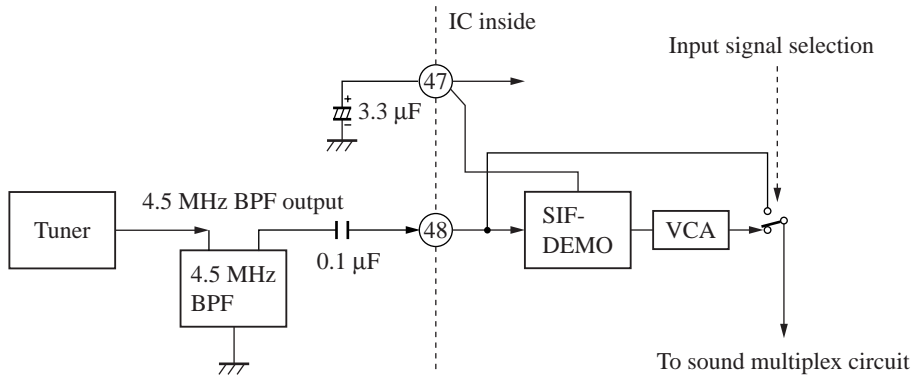

(7) The case adjustment is necessary (Base band mode)

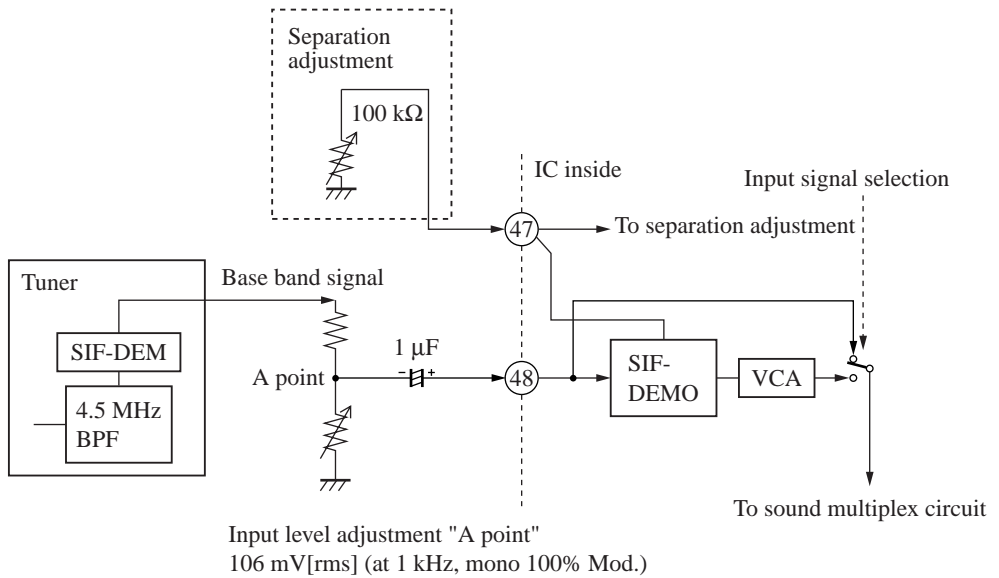

Note) Pin 47 must be open when separation is adjusted with the potentiometer of input level adjustment.



■ Application Notes (continued)

3. I<sup>2</sup>C bus of this IC (continued)

7) Descriptions on data bit function

(1) Sub address 00000000

Note) The underlined values are for the initial status at power on.

Function	Value	Conditions
Rec./PB changeover	0	HiFi-PB Mode
	<u>1</u>	HiFi-EE (Rec.) Mode
HiFi input changeover	<u>00</u>	Sound multiplex select
	01	Ext.1 select (pin 9, pin 14 input)
	10	Ext.2 select (pin 10, pin 15 input)
	11	Ext.3 select (pin 2, pin 4 input)
NOR input changeover	00	Setting is disable.
	01	R-channel selection of HiFi input signal
	10	L-channel selection of HiFi input signal
	<u>11</u>	L+R mixed selection of HiFi input signal

(2) Sub address 00000001

Note) The underlined values are for the initial status at power on.

Function	Value	Conditions
Output gain changeover	0	Line output 1 (typ. -6.0 dBS for typical input)
	<u>1</u>	Line output 2 (typ. -7.5 dBS for typical input)
Noise det. threshold value (Normal det. level)	<u>00</u>	High (Least to be NOR)
	01	MID
	10	Low
	11	Off
Output mode changeover	<u>00</u>	HiFi select
	01	HiFi + NOR mix. select
	10	NOR select
	11	BS monitor select
Output channel changeover	<u>00</u>	Stereo selection
	01	L-ch. BPF monitor selection at L-ch. selection and PB
	10	R-ch. BPF monitor selection at R-ch. selection and PB
	11	Setting is disable.

### ■ Application Notes (continued)

#### 3. I<sup>2</sup>C bus of this IC (continued)

##### 7) Descriptions on data bit function (continued)

##### (3) Sub address 00000010

Note) The underlined values are for the initial status at power on.

Function	Value	Conditions
FM mix. ratio at recording	<u>00</u>	FM carrier R/L = 11 dB
	01	FM carrier R/L = 10 dB
	10	FM carrier R/L = 9 dB
	11	FM carrier R/L = 8 dB
DOC select	<u>0</u>	DOC on
	1	DOC off
ENV select	<u>0</u>	ENV on
	1	Force NOR (0/5 V)
V <sub>CC2</sub> selection	0	Select at using V <sub>CC2</sub> = 9 V (output DC = 4.5 V)
	<u>1</u>	Select at using V <sub>CC2</sub> = 12 V (output DC = 6.0 V)

##### (4) Sub address 00000011

Note) The underlined values are for the initial status at power on.

Function	Value	Conditions
Power save	<u>0</u>	Power save off
	1	Power save on
Rec. amp. mode	<u>00</u>	Normal mode (0 dB)
	01	S-VHS mode (-2 dB)
	10	Over rec. mode (2 dB)
	11	Prohibited
HEAD SW mode	<u>0</u>	Normal mode AFF = H1, Ch.1
	1	Turn over mode AFF = H1, Ch.2

### ■ Application Notes (continued)

#### 3. I<sup>2</sup>C bus of this IC (continued)

##### 7) Descriptions on data bit function (continued)

##### (5) Sub address 00000110

Note) The underlined values are for the initial status at power on.

Function	Value	Conditions
ZAP mode (use for the inspection)	<u>0</u>	DAC mode
	1	PROM mode
VCO f <sub>O</sub> -adj.	<u>0</u>	f <sub>O</sub> -adj. off
	1	f <sub>O</sub> -adj. start on
f <sub>SC</sub> select	<u>00</u>	3.58 MHz select
	01	4.43 MHz select
	10	7.16 MHz select
	11	8.86 MHz select
VCO f <sub>O</sub> -check	<u>0</u>	Check off
	1	Check on
INSW-mute (SW30, SW31)	<u>0</u>	INSW-mute off
	1	INSW-mute on

##### (6) Sub address 00000111

Note) The underlined values are for the initial status at power on.

Function	Value	Conditions
f <sub>O</sub> monitor	<u>0</u>	Monitor off
Pin 29	1	Monitor on
Hold-test (use for the inspection)	<u>0</u>	Test mode off
	1	Test mode on
ENC/sound multiplex-test (use for the inspection)	<u>00</u>	Test mode off
	01	Sound multiplex test mode on
	10	ENC test mode on
	11	Test mode off
FM-test (use for the inspection)	<u>0</u>	Test mode off
	1	Test mode on

■ Application Notes (continued)

3. I<sup>2</sup>C bus of this IC (continued)

7) Descriptions on data bit function (continued)

(7) Sub address 00001011

Note) The underlined values are for the initial status at power on.

Function	Value	Conditions
Sound multiplex test 1 (use for the inspection)	<u>0</u>	Test mode off
	1	Test mode on (L-ch.: SIFOUT, R-ch.: 3.5f <sub>H</sub> BPF)
Sound multiplex adj. test (use for the inspection)	<u>0</u>	Test mode off
	1	Test mode on (L-ch.: 952 BPF, R-ch.: Sub De-emph.)
Bilingual mode select	<u>00</u>	Both
	01	Main
	10	Sub
	11	Setting is disable.
Forced mono	<u>0</u>	Forced mono off
	1	Forced mono on
Sound multiplex mute	<u>0</u>	Sound multiplex mute off
	1	Sound multiplex mute on
Sound multiplex input select	<u>0</u>	SIF 4.5 MHz input
	1	Base band input

8) Usage notes of I<sup>2</sup>C bus

• Serial data transmission

When transmitting one line of data, it is necessary to send the Start and Stop conditions at each transmission. To change a serial mode setting, you can change it by sending one line of the changed data.

< Example: In case of sending all data of four lines >

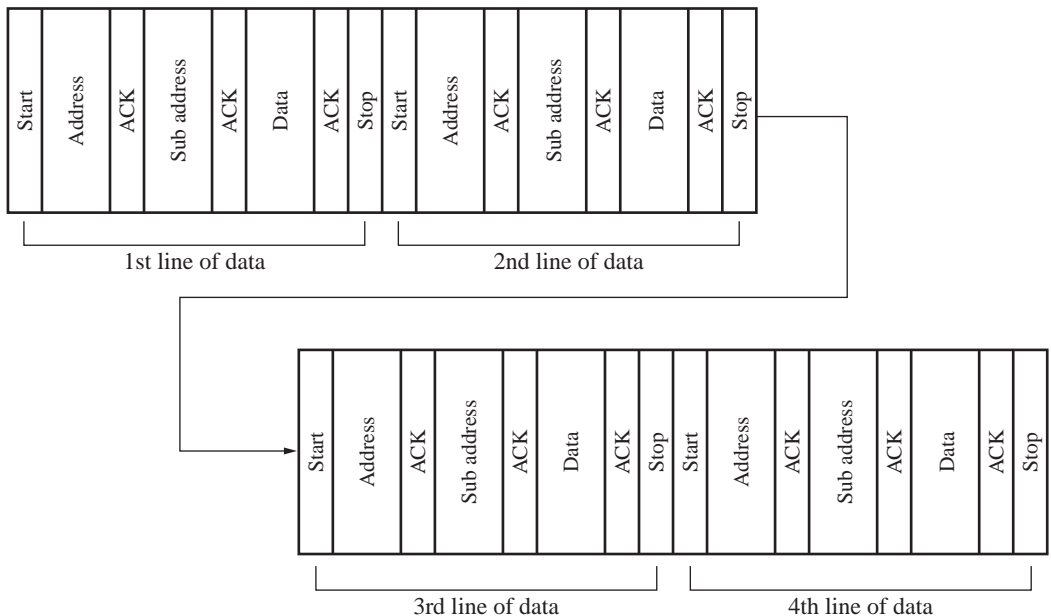

Application Circuit Example

