

AN3824K

VCR Capstan Direct Motor Drive Circuit

Outline

The AN3824K is an integrated circuit designed to drive a VCR capstan DD motor.

Features

- Three-phase full-wave operation.
- Torque ripple canceller built-in.
- Operation voltage of motor (V_M) = 24V (max.)
- Max. output current (I_o max.) = 1A
- Supply voltage : 5V

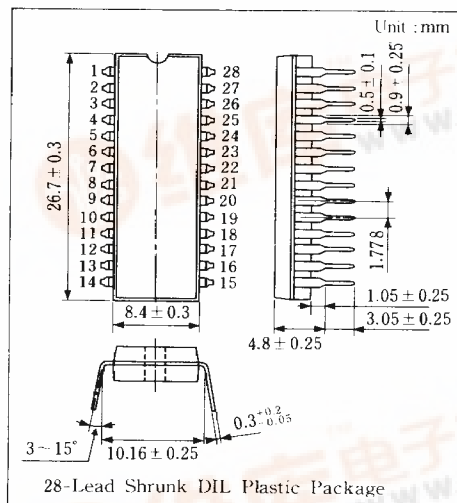

Block Diagram

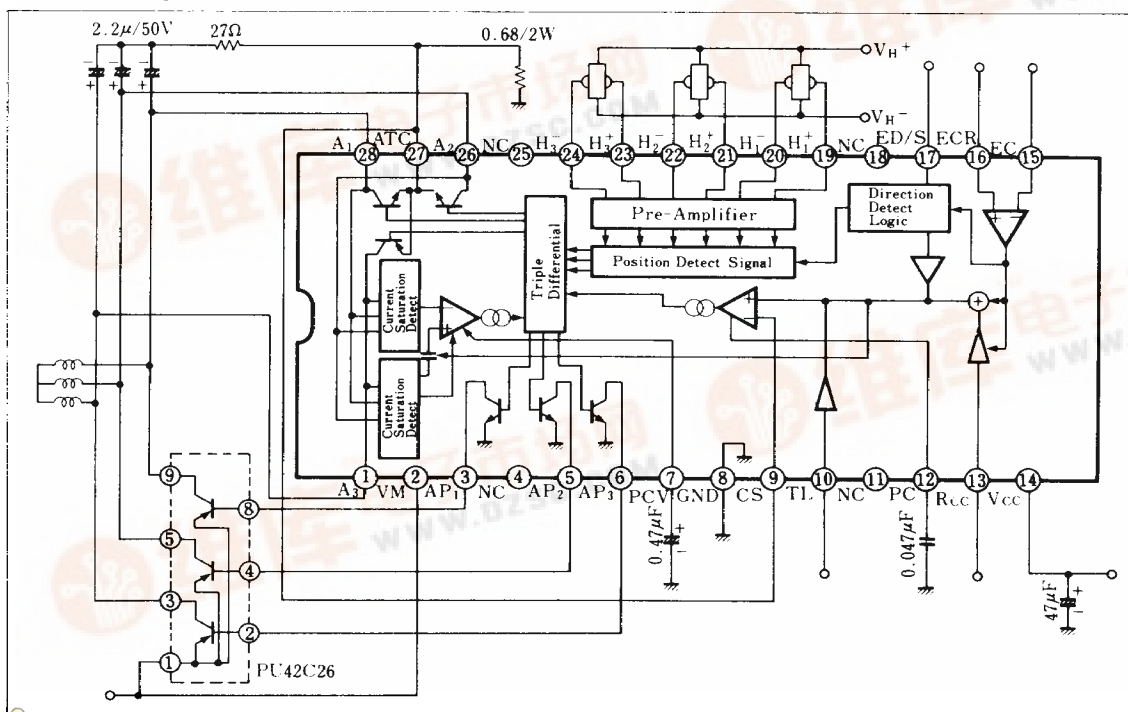

■ Pin

Pin No.	Pin Name	Pin No.	Pin Name
1	NPN Output 3 on Ground Side	15	Torque Command Input
2	Power Supply Terminal for Motor	16	Torque Command Reference Input
3	PNP Pre-drive Output 1 on V _{CC} Side	17	Command Input for Rotational Direction
4	NC	18	NC
5	PNP Pre-drive Output 2 on V _{CC} Side	19	Hall Element Input
6	PNP Pre-drive Output 3 on V _{CC} Side	20	Hall Element Input
7	Phase Compensation for Voltage Feedback Circuit	21	Hall Element Input
8	GND	22	Hall Element Input
9	Current Detect Terminal	23	Hall Element Input
10	Torque Limit	24	Hall Element Input
11	NC	25	NC
12	Phase Compensation for Current Feedback Circuit	26	NPN Output 2 on Ground Side
13	Torque Ripple Rectification	27	Total Current Output
14	Voltage Supply Terminal	28	NPN Output 1 on Ground Side

■ Absolute Maximum Ratings (Ta = 25°C)

Item	Symbol	Rating	Unit
Supply Voltage	V _{CC}	6	V
Motor Supply Voltage	V _{M(24)}	24	V
Motor Drive Current	I ₁ , I ₂₆ , I ₂₈	±1.5	A
Output Pin Voltage	V ₁ , V ₂₆ , V ₂₈	24	V
Power Dissipation	P _D	1790	mW
Operating Ambient Temperature	T _{opr}	-20 ~ +70	°C
Storage Temperature	T _{stg}	-55 ~ +150	°C

■ Electrical Characteristics (Ta = 25°C)

Item	Symbol	Test Circuit	Condition	min.	typ.	max.	Unit
Supply Voltage	I _{CC}	1	V _{CC} = 5V			1.5	mA
Torque Reference Voltage	ECR	2	V _{CC} = 5V	2.3		3	V
Torque Command Voltage	EC	2	V _{CC} = 5V, ECR = 2.5V	1		4	V
Torque Command Voltage offset	EC _{offset}	2	V _{CC} = 5V, ECR = 2.5V	-150		+150	mV
Torque Command Dead Zone	EC _{dead}	2	V _{CC} = 5V, ECR = 2.5V	60		150	mV
Output Idle Voltage	EC _{idle}	2	V _{CC} = 5V, ECR = 2.5V			4	mV
Input/Output Gain	G _{io}	2	V _{CC} = 5V, ECR = 2.5V	0.56		0.7	times
Forward Motor Drive Command Voltage	E _{D-F}	3	V _{CC} = 5V, ECR = 2.5V			0.9	V
STOP Command Voltage	E _{D-S}	3	V _{CC} = 5V, ECR = 2.5V	1.3		3	V
Reverse Motor Drive Command Voltage	E _{D-R}	3	V _{CC} = 5V, ECR = 2.5V	3.5			V
Hall Element Input Allowable Voltage	V _{H-ALLOW}	4	V _{CC} = 5V, ECR = 2.5V	1.2		2.35	V

■ Electrical Characteristics (Ta = 25°C) (Cont'd)

Item	Symbol	Test Circuit	Condition	min.	typ.	max.	Unit
Hall Element Input Conversion Offset	$V_{H-OFFSET}$	5	$V_{CC}=5V, ECR=2.5V$	-5		5	mV
Saturation Voltage On Ground Side	$V_{NS(sat)}$	6	$V_{CC}=5V, I_a=700mA$			1.8	V
Torque Limit Current Sense Offset	$T_L-C(stoffset)$	7	$V_{CC}=5V, V_{TL}=700mW$	34		70	mV
Ripple Cancel Output	V_{RCC}	8	$V_{CC}=5V, V_{TL}=700mW$	50			mV
Ripple Cancel OFF Voltage	V_{RCC-ON}	8	$V_{CC}=5V, V_{TL}=700mW$			2.3	V
Ripple Cancel ON Voltage	$V_{RCC-OFF}$	8	$V_{CC}=5V, V_{TL}=700mW$	2.7			V

Note: Operating Supply Voltage Range : $V_{CC(oper)}=4.5\sim 5.5V$

Test Circuit 1 (I_{CC})

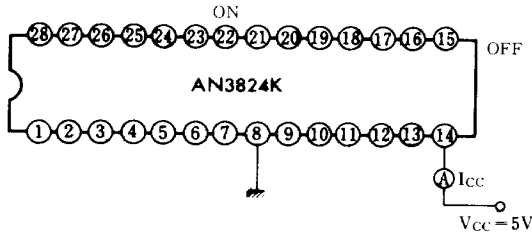

1. Measure an inflow current to V_{CC} (Pin⑭) when V_{CC} (Pin⑨) and GND (Pin⑧) is set at 5V and 0V respectively.

Test Circuit 2 (ECR, EC, EC_{offset} , EC_{dead} , EC_{idle} , G_{io})

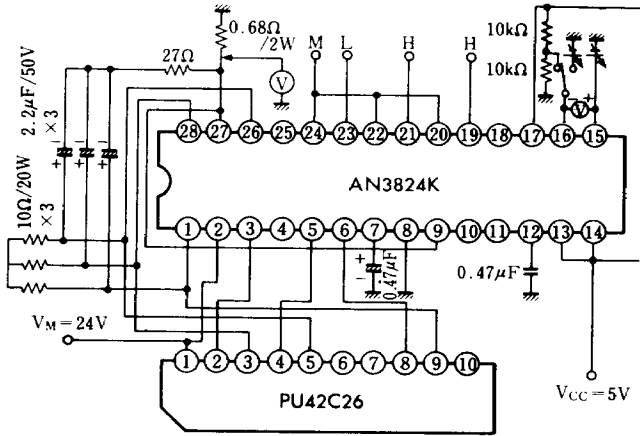

1. Input conditions are as follows
 Provided, H: 1.9V
 M: 1.7V
 L: 1.5V

H_1^+ (19)	H_2^+ (21)	H_3^+ (23)	H_c (20, 22, 24)
H	H	L	M

2. Check V characteristics when ECR is set at 2.3~3V (ECR, EC). That is, measure AC (Pin⑳) voltage after ECR (Pin⑩) is set and EC (Pin⑮) is made variable. (See Fig.-1.)
3. Make ECR=2.5V, make EC variable from 0 to V_{CC} and measure ATC (EC_{offset} , EC_{dead} , EC_{idle} , G_{io}). (See Fig.-1.)

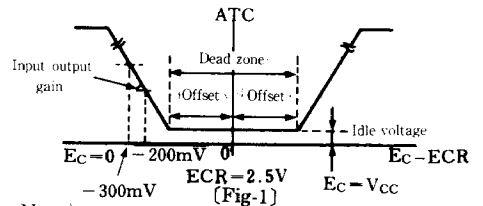

Note)

- Idle voltage denotes ATC voltage at the dead zone.
- Torque command voltage is the characteristics in Fig.-2.

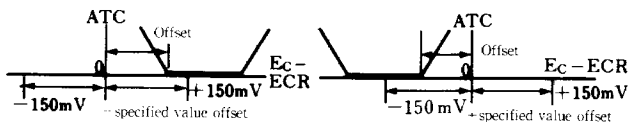

(Fig-2)

Test Circuit 3 (E_D-F, E_D-S, E_D-R)

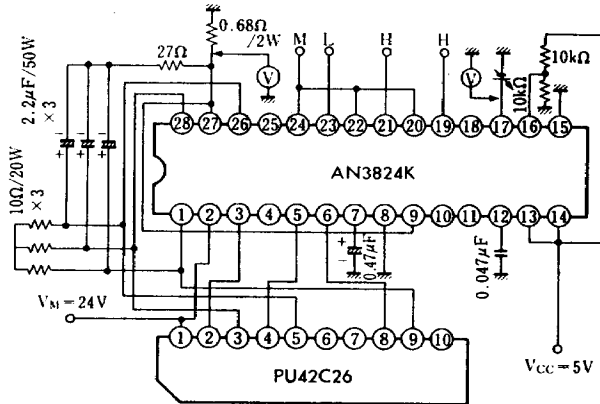

Test Circuit 4 (V_H-ALLOW)

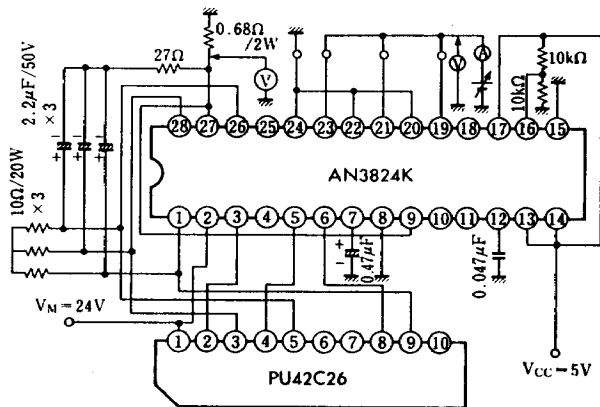

Test Circuit 5 (V_H-OFFSET)

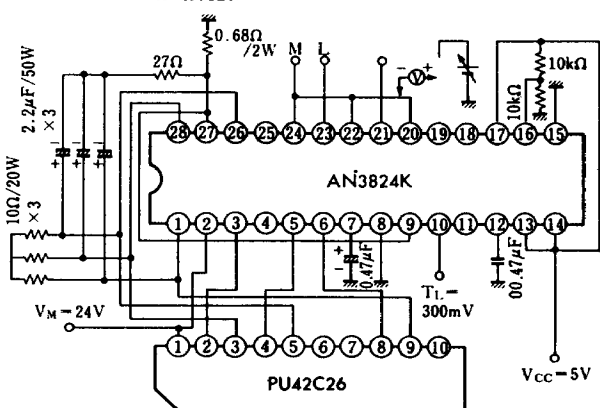

Input setting has three types as shown in Table3. Test circuit above is the case of setting1. In this case, the measuring method is as follows. The same sequence will be taken in input settings 3 and 5.

1. Set the input conditions as shown in Table 2 and ED/S (Pin⑦) at 0V.
2. Gradually increasing the voltage of ED/S, measure the threshold voltage of characteristics diagram. (See Fig-3)

Table2

EC15	H ₁ ⁺ 19	H ₂ ⁺ 21	H ₃ ⁺ 23	H _c 20②④
0V	H	H	L	M

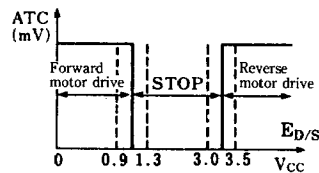

[Fig-3]

1. Connecting H₁⁺ (Pin⑩), H₂⁺ (Pin⑫) and H₃⁺ (Pin⑬), apply voltage and measure the range where flowing current does not change at 0.5~7.0μA.

Note) Change of current when the voltage is applied from 0V will be as shown in Fig-4.

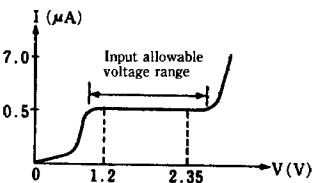

[Fig-4]

1. Select the input setting 1.
2. Observe an electric potential change of A₁ (Pin⑳) when (H₁⁺-H₁⁻) is changed at 1mV STEP. (See Fig-5.)
3. Differential voltage of input (H₁⁺-H₁⁻) when A₁ is to be changed from L to H is within ± 5mV.

Table3

Input setting	Input			Output		
	H ₁ ⁺	H ₂ ⁺	H ₃ ⁺	A ₁	A ₂	A ₃
1	Change	H	L	Change	H	L
3	L	Change	H	L	Change	H
5	H	L	Change	H	L	Change

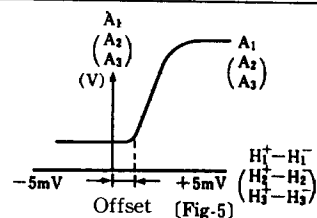

<Saturation Detect Voltage Characteristics>

To prevent the power Tr from being saturated, detect the collector voltage. When reaching a fixed level, decrease the base current to prevent the electric potential of collector and its decrease. The characteristics are shown in Fig.-9.

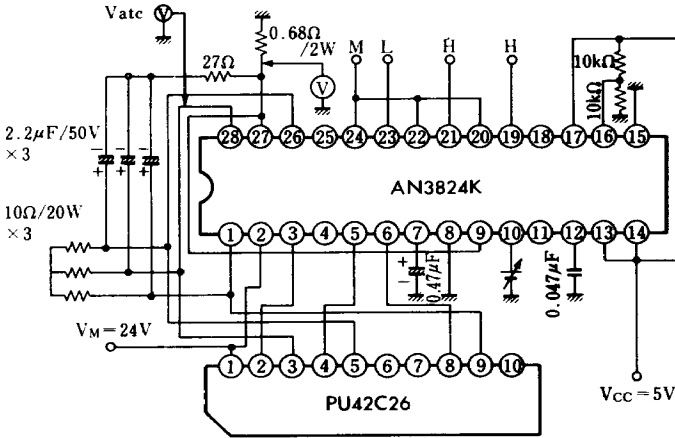

V_{CE} of Tr when a motor is actually rotated will be $V_i - V_{atc}$.

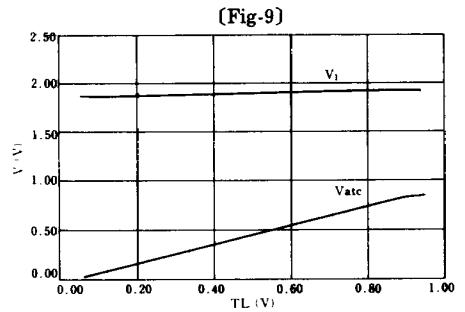

■ Application Circuit

