

AN4250, AN4250S, AN6593

Single Low Power Consumption Operational Amplifiers

Overview

The AN4250, the AN4250S, and the AN6593 are single operational amplifiers which can be operated with very low power consumption. Moreover, they have wide range ($\pm 1V$ to $\pm 18V$) of supply voltage, and electrical characteristics such as power consumption and input bias current can be programmed according to the current value set by outer resistor.

They are suitable for applications to various electronic circuits such as portable electronic equipments operated by the battery.

Features

- Wide supply voltage rang ($\pm 1V$ to $\pm 18V$)
- Electrical characteristics programmable by set current
- Phase compensation circuit built in
- Output short-circuit protection
- Offset null

Block Diagram

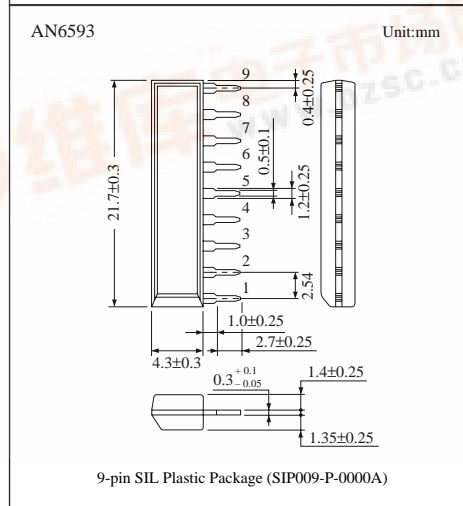
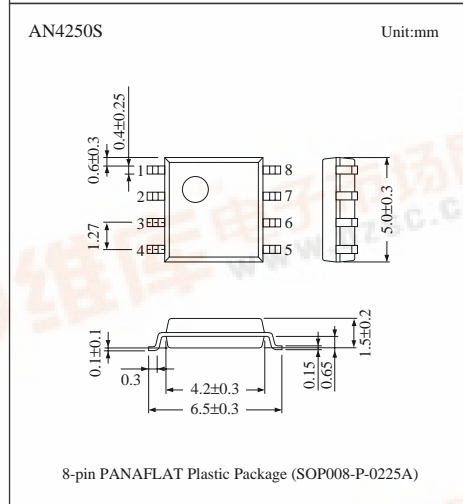
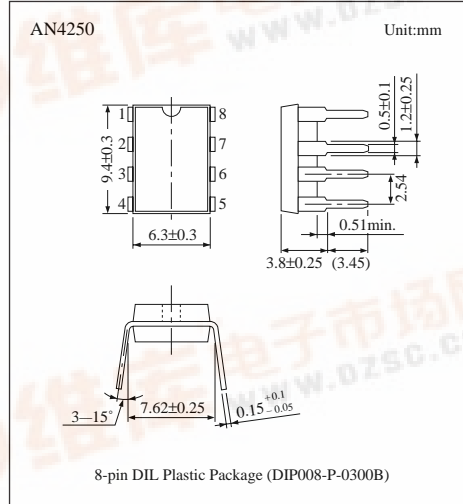
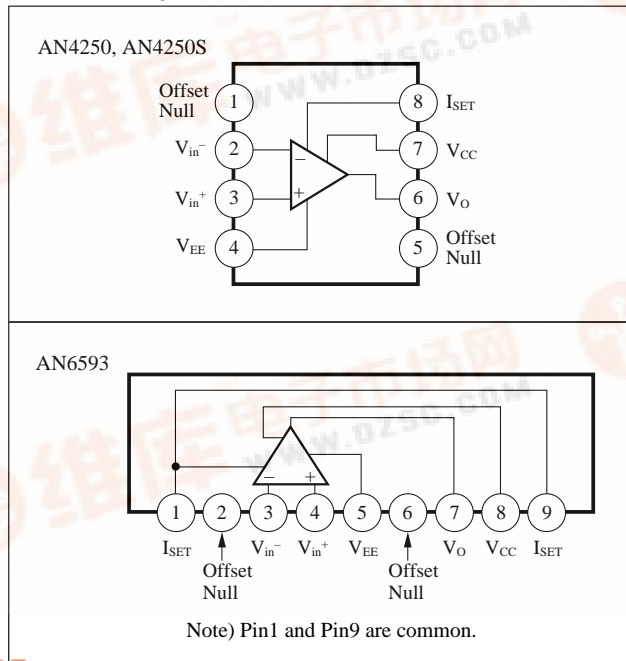

■ Pin Descriptions

〈AN4250, AN4250S〉

Pin No.	Pin name
1	Offset null
2	Inverting input
3	Non inverting input
4	V _{EE} (GND)
5	Offset null
6	Output
7	V _{CC}
8	I _{SET}

〈AN6593〉

Pin No.	Pin name
1	I _{SET}
2	Offset null
3	Inverting input
4	Non inverting input
5	V _{EE} (GND)
6	Offset null
7	Output
8	V _{CC}
9	I _{SET}

■ Absolute Maximum Ratings (Ta=25°C)

Parameter		Symbol	Rating	Unit
Voltage	Supply voltage	V _{CC}	±18	V
	Differential input voltage	V _{ID}	±30	V
	Common-mode input voltage	V _{ICM}	±15	V
Power dissipation	AN4250, AN6593	P _D	500	mW
	AN4250S		360	
Operating ambient temperature		T _{opr}	-20 to +75	°C
Storage temperature	AN4250, AN6593	T _{stg}	-50 to +150	°C
	AN4250S		-50 to +125	

■ Electrical Characteristics (V_{CC}=15V, V_{EE}=-15V, Ta=25°C)

Parameter	Symbol	Condition	I _{SET} =1μA		I _{SET} =10μA		Unit
			min	max	min	max	
Input offset voltage	V _{I(offset)}	R _S ≤ 100kΩ	—	5	—	6	mV
		V [±] = ±1.5V, R _S ≤ 100kΩ	—	5	—	6	
Input offset current	I _{IO}		—	6	—	20	nA
Input bias current	I _{Bias}		—	10	—	75	nA
		V [±] = ±1.5V	—	10	—	75	
Large signal voltage gain	G _V	V _O = ±10V, R _L = 100kΩ	96	—	—	—	dB
		V _O = ±10V, R _L = 10kΩ	—	—	96	—	
Supply current	I _{CC}		—	11	—	100	μA
		V [±] = ±1.5V	—	8	—	90	
Power consumption	P _C		—	330	—	3000	μW
		V [±] = ±1.5V	—	24	—	270	
Input voltage range	V _{CM}		±13.5	—	±13.5	—	V
		V [±] = ±1.5V	±0.6	—	±0.6	—	
Maximum output voltage	V _{O(max.)}	R _L = 100kΩ	±12	—	—	—	V
		V [±] = ±1.5V, R _L = 100kΩ	±0.6	—	—	—	
Maximum output voltage	V _{O(max.)}	R _L = 10kΩ	—	—	±12	—	V
		V [±] = ±1.5V, R _L = 10kΩ	—	—	±0.6	—	
Common-mode rejection ratio	CMR	R _S ≤ 10kΩ	70	—	70	—	dB
Supply voltage rejection ratio	SVR	R _S ≤ 10kΩ	74	—	74	—	dB

Normal Connection

(a)

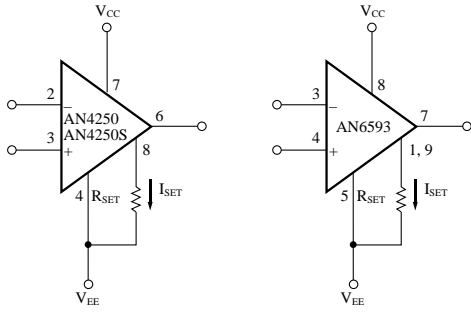

$$I_{SET} \cong \frac{V_{CC} + |V_{EE}| - 0.5}{R_{SET}}$$

(b)

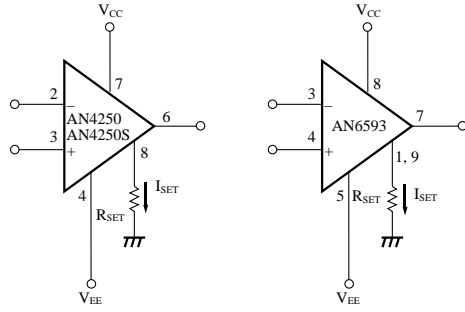

$$I_{SET} \cong \frac{V_{CC} - 0.5}{R_{SET}}$$

Offset Control

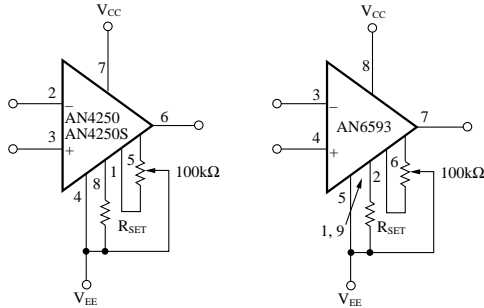

Characteristics Curve

