

AN6150

Speech Network Circuit

Overview

The AN6150 is an integrated circuit designed for telephone speech network. It has the basic function necessary to apply a sound signal onto the line and is applicable for various types of handsets.

Features

- Wide operating voltage range : 3 to 11.5V
- Built-in amplifiers for "Dial Tone" and "DTMF"
- Amplifier output switchable.
- Each amplifier gain automatically changeable depending on line current.
- Various types of microphones and receivers are available.

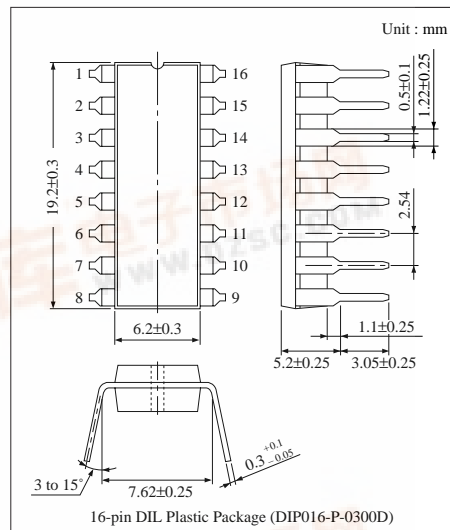

Block Diagram

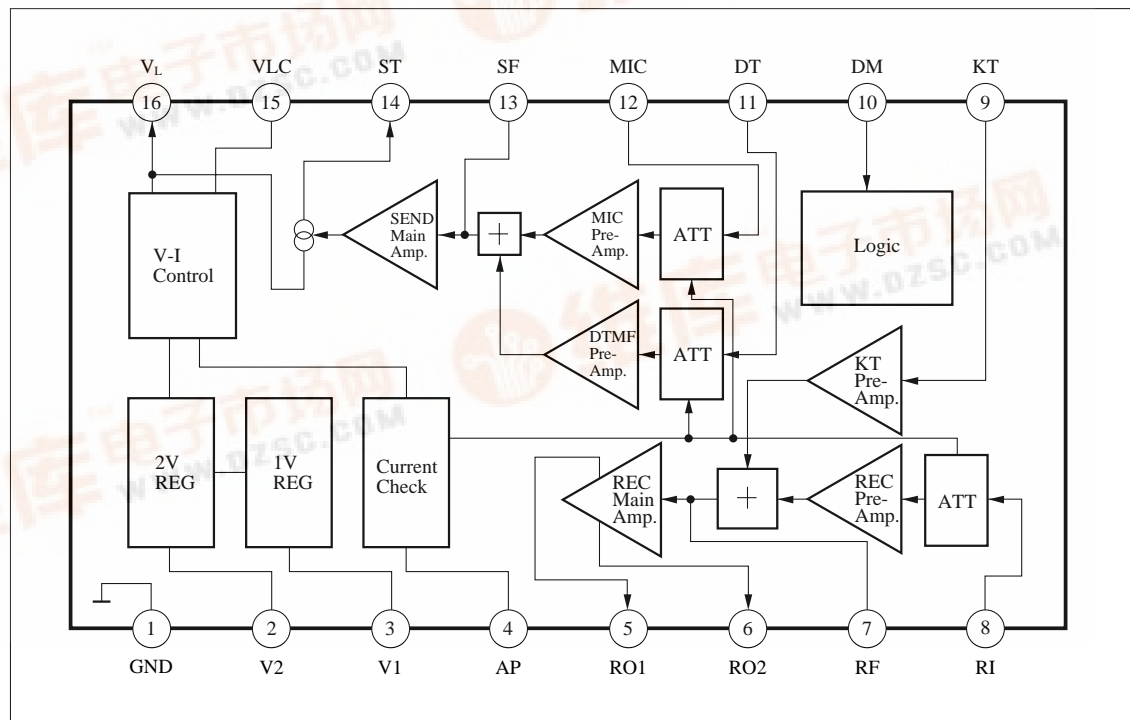

■ Pin Descriptions

Pin No.	Pin name	Pin No.	Pin name
1	GND	9	KEY In TONE input
2	2V REG.	10	Dial mute SW
3	1V REG.	11	DTMF input
4	ATT control	12	MIC input
5	REC output	13	Transmission filter
6	REC output	14	SIDE tone
7	REC filter	15	LIN filter
8	REC input	16	LIN

■ Absolute Maximum Ratings (Ta=25°C)

Parameter	Symbol	Rating	Unit
Line voltage	V _L	14.4	V
Line current	I _L	135	mA
Power dissipation (Ta=60°C)	P _D	1380	mW
Operating ambient temperature	T _{opr}	-30 to + 75	°C
Storage temperature	T _{stg}	-55 to + 150	°C

■ Electrical Characteristics (I_L=40mA, f_{in}=1kHz, Ta=25°C)

Parameter	Symbol	Condition	min	typ	max	Unit
Receive System						
Receiver gain *1	G _{V-R}	V _i =-45dBm	-7	-4.5	-2	dBm
Receiver output distortion *1	THD _{-R}	V _i =-45dBm	—	1	5	%
Max. receiver level *1	V _{O-R}	THD=5%	0	4	—	dBm
Receiver auto pad *1	ΔAP _{-R}	V _i =-45dBm, DI _L =100 to 20mA	-5.5	-3	-0.5	dB
KEY IN TONE gain *1	G _{V-KT}	V _i =-40dBm, Dial Mute SW- ON	-25	-22.5	-20	dBm
Transmission System						
Transmission gain *2	G _{V-T}	V _i =-45dBm	-6	-4	-2	dBm
Transmission output distortion *2	THD _{-T}	V _i =-45dBm	—	1	5	%
Max. transmission level *2	V _{O-T}	THD=5%	-2.2	2.8	—	dBm
Transmission auto pad *2	ΔAP _{-T}	V _i =-45dBm, DI _L =100 to 20mA	-6.5	-3.5	-1	dB
DTMF gain *2	G _{V-DT}	V _i =-35dBm, Dial Mute SW- ON	-8	-6	-4	dBm
DTMF output distortion *2	THD _{-DT}	V _i =-35dBm, Dial Mute SW- ON	—	1	5	%
DTMF auto pad *2	ΔAP _{-DT}	V _i =-35dBm, DI _L =100 to 20mA	-6	-4	-2	dB
Power Supply						
DC line voltage (1)	V _{L-1}	I _L =12mA	2.4	3	3.6	V
DC line voltage (2)	V _{L-2}	I _L =127mA	5.4	7.8	10.2	V
Internal supply voltage	V _{CC}	I _L =12mA	1.7	2.0	2.3	V

*1 Connect the 1kΩ load between Pins5 and 6 for measurement.

*2 Connect the 600Ω receiver impedance between Pins16 and 1 and measure it at the receiver side.

■ Electrical Characteristics (cont.) ($I_L=40\text{mA}$, $f_{in}=1\text{kHz}$, $T_a=25^\circ\text{C}$)

Parameter	Symbol	Condition	min	typ	max	Unit
Dial Mute input						
Dial mute OFF	V_{DM-H}		0.8	—	V_{CC}	V
Dial mute ON	V_{DM-L}		—	—	0.3	V
Input current (1)	I_{DM-H}	$V_{DM}=V_{CC}$	-2.0	0.1	2.0	μA
Input current (2)	I_{DM-L}	$V_{DM}=0\text{V}$	-2.0	-0.2	-0.02	μA
Receiver System						
K. T. output distortion *1, 4	THD_{KT}	$V_i=-42\text{dBV}$, $I_L=40\text{mA}$	—	1	—	%
Mute						
K.T. mute *1, 4	M_{KT}	$V_i=-15\text{dBV}$, Dial mute SW- OFF	40	—	—	dB
MIC mute *2, 4	M_T	$V_i=-40\text{dBV}$, Dial mute SW- ON	60	—	—	dB
DTMF mute *2, 4	M_{DT}	$V_i=-28\text{dBV}$, Dial mute SW- OFF	40	—	—	dB
Power Supply						
AC impedance (1) *3, 4	Z_{AC-1}	$I_L=30\text{mA}$, $f_{in}=1\text{kHz}$	400	670	800	Ω
AC impedance (2) *3, 4	Z_{AC-2}	$I_L=90\text{mA}$, $f_{in}=1\text{kHz}$	400	620	800	Ω

*1 Connect the $1\text{k}\Omega$ load between Pins5 and 6 for measurement

*2 Connect the 600Ω receiver impedance between Pins16 and 1 measure it at the receiver side.

*3 Connect  between Pins16 and 1 for measurement.

*4 Characteristics above are of reference value for design but not guaranteed values.

■ Characteristics Curve

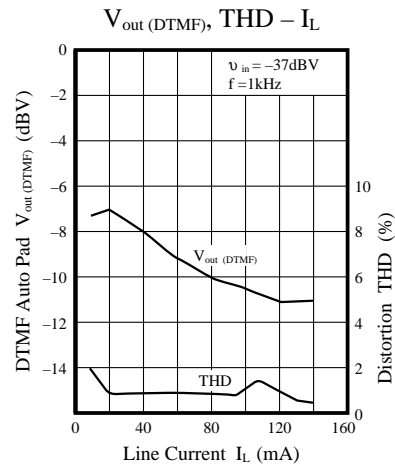
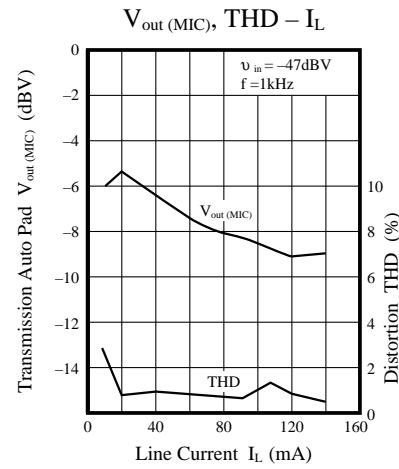
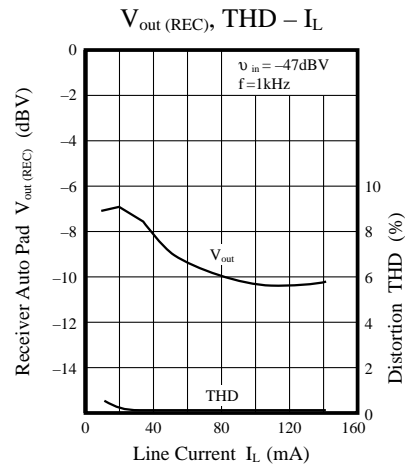
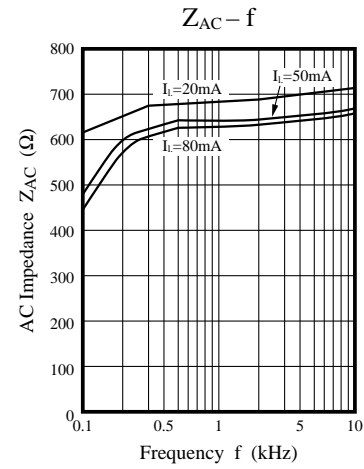
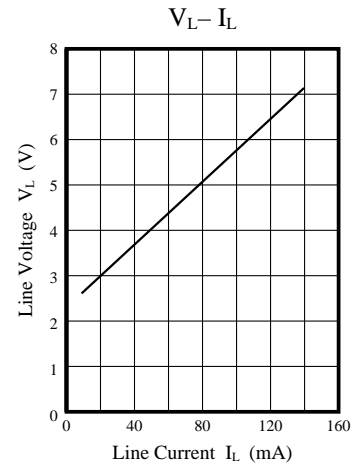

■ Application Circuits

- In case of using ceramic receiver

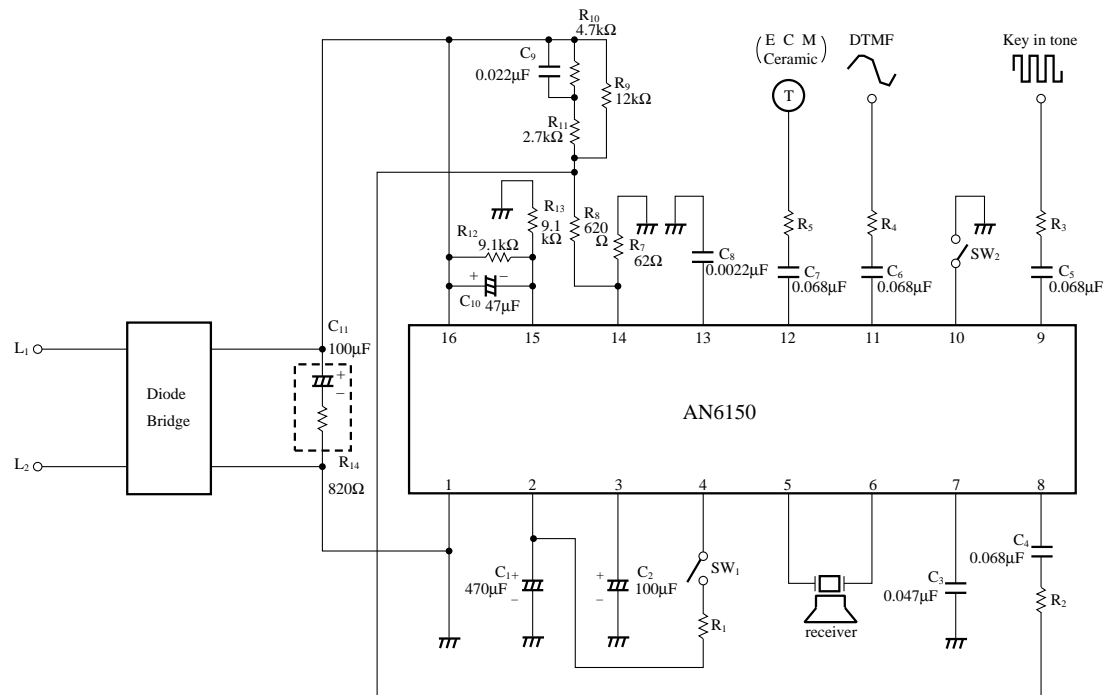

- In case of using low impedance receiver

