

AN6182K, AN6182S

Recording and playing amplifier IC for answering telephones

Overview

The AN6182K and AN6182S are recording and playing amplifier ICs for answering telephones. They incorporate an ALC circuit, recording and playing amplifiers, a loudspeaker amplifier, and a VOX circuit.

Features

- Incorporates recording and playing amplifiers.
- Incorporates a loudspeaker amplifier.
- Incorporates a VOX circuit.
- Incorporates a magnetic-head circuit to provide for one-tape cassette recording.
- Incorporates 4 control circuits.

Block Diagram

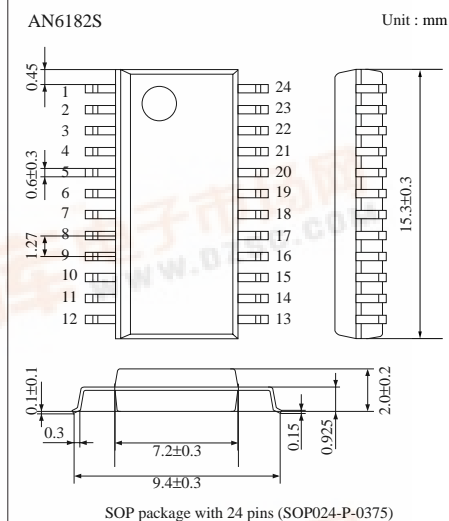
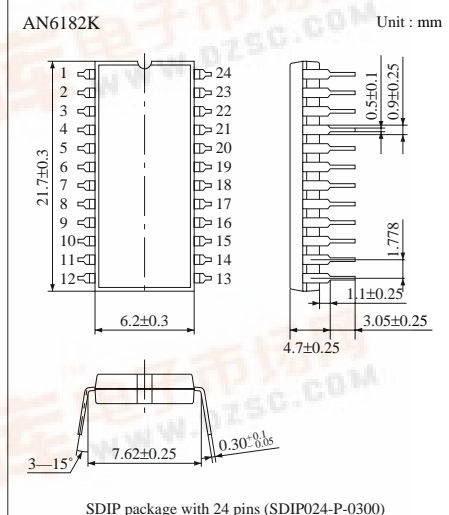
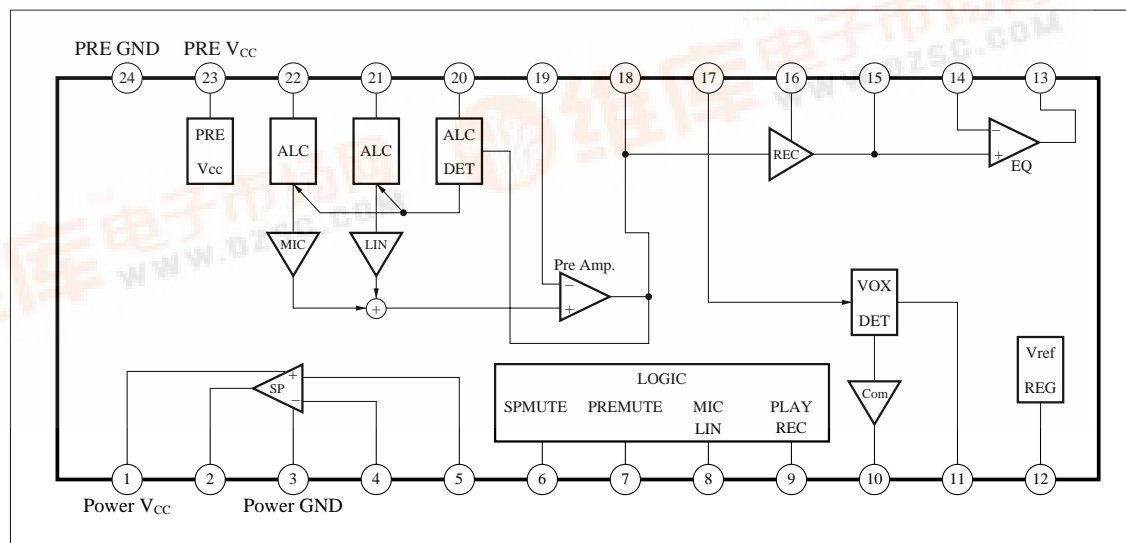

■ Absolute Maximum Ratings (Ta=25°C)

Parameter	Symbol	Rating	Unit
Supply voltage ^{Note 1)}	V _{CC}	9.0	V
Supply current ^{Note 1)}	I _{CC}	600	mA
Power dissipation ^{Note 2)}	AN6182K	700	mW
	AN6182S	338	mW
Operating ambient temperature	T _{opr}	-20 to + 75	°C
Storage temperature	AN6182K	-55 to + 150	°C
	AN6182S	-55 to + 125	°C

Note 1) The IC must be used under the condition $V_{CC} \times I_{CC} < P_D$.

Note 2) Ta=60°C

■ Operating Supply Voltage Range

Parameter	Symbol	Range
Operating supply voltage range	V _{CC}	4.5 to 9.6V

■ Electrical Characteristics

Parameter	Symbol	Condition	min	typ	max	Unit
MIC preamp. gain	G _V	Vi=-64dBm	48.5	50.5	52.5	dB
MIC preamp. ALC output	V _O	Vi=-30dBm	-11	-9	-7	dBm
MIC preamp. output noise voltage	V _{no}	DIN/AUDIO, Rg=10kΩ	—	1.2	2.5	mVrms
LIN preamp. gain	G _V	Vi=-64dBm	48.5	50.5	52.5	dB
LIN preamp. ALC output	V _O	Vi=-30dBm	-11	-9	-7	dBm
LIN preamp. output noise voltage	V _{no}	DIN/AUDIO, Rg=10kΩ	—	1.2	2.5	mVrms
VOX sensitivity (1)	V _{S1}	Vi=-35dBm	3.5	4.8	—	V
VOX sensitivity (2)	V _{S2}	Vi=-29dBm	—	0.025	0.5	V
REC head drive	G _V	Rg=1kΩ, Vi=-10dBm	-18.7	-16.2	-13.7	dBm
PRAY/EQ amp. gain	G _V	Vi=-60dBm	39.5	41.5	43.5	dB
PRAY/EQ amp. output noise voltage	V _{no}	DIN/AUDIO, Rg=10kΩ	—	0.3	1.2	mVrms
POWER amp. gain	G _V	Vi=-20dBm	14.5	17	19.5	dB
POWER amp. max output voltage	V _O	R _L =8Ω, THD=5%	100	200	—	mW
POWER amp. output noise voltage	V _{no}	DIN/AUDIO, Rg=10kΩ	—	0.2	1.0	mVrms
Pre. V _{CC} voltage	V _{CC}	No signal, V _{CC} =5V	3.6	4.0	4.4	V
ΔPRE V _{CC} voltage	V _{CC}	No signal, V _{CC} =5V I _{CC(Pre)} =0 to 6mA	-0.25	-0.07	0.1	V
Total circuit current (1)	I _{total-1}	No signal recording mode (SP ON)	12	20	30	mA
Total circuit current (2)	I _{total-2}	No signal recording mode (SP OFF)	2	3.3	5	mA

■ Pin Descriptions

Pin No.	Symbol	Description
1	Power V _{CC}	Loudspeaker amplifier power supply input An external power supply connects to this pin. The input supply voltage range is 4.5 to 9V.
2	Power out	Loudspeaker amplifier output This pin connects through an electrolytic capacitor to a loudspeaker with a load impedance of 8Ω or more. This pin is effective only when Pin6 is high.
3	Power GND	Loudspeaker amplifier ground This pin connects to an external ground. This ground should be separated from that of the preamplifier circuits.
4	Power NF	Loudspeaker amplifier inverse input A combination of resistors and a capacitor connected between this pin and Pin2 and the ground determines the gain and frequency characteristics of the loudspeaker amplifier.
5	Power in	Loudspeaker amplifier non-inverse input Signals should be input to this pin through a capacitor. The expected input impedance is typically 27kΩ.
6	SP mute control	Loudspeaker amplifier mute control If the voltage level at this pin is high, the loudspeaker amplifier turns ON, and if low, turns OFF.
7	Preamp. mute control	Preamplifier mute control If the voltage level at this pin is high, the preamplifier turns OFF, thereby blocking the MIC and line preamplifier outputs. If the voltage is low, the preamplifier turns ON. Even if the preamplifier is turned OFF (mute ON), signals input to Pin9 are output from Pin18.
8	MIC/LIN control	MIC/line preamplifier switching If the input to Pin7 is low and the input to this pin is high, then the line preamplifier turns ON and the MIC preamplifier turns OFF. If the input to Pin7 is low and the input to this pin is low, then the line preamplifier turns OFF and the MIC preamplifier turns ON.
9	REC/PLAY control	REC/PLAY switching If the input to this pin is high, the recording amplifier turns OFF, and the play equalizer amplifier turns ON. If low, the recording amplifier turns ON, and the play equalizer amplifier turns OFF.
10	VOX out	VOX output The VOX detection signal is output from this pin. This pin should be connected through a resistor (100-200kΩ) to the power supply.
11	VOX DET	VOX detection control This pin should be connected through a resistor (10 to 470kΩ) and a capacitor in parallel to the ground. The resistance determines the sensitivity of VOX detection.
12	V _{REF}	Internal reference supply voltage output This pin should be grounded through a 100μF capacitor.
13	EQ-amp. out	Equalizer amplifier output Amplified play signals from the head are output from this pin. A resistor and capacitors connected between this pin and Pin14 determine the equalizer characteristics.
14	EQ-amp. NF	Equalizer amplifier inverse input This pin connects through a resistor to Pin13 to determine the equalizer characteristics. The expected input impedance is typically 10kΩ.
15	Head in/out	To the REC/PLAY head A REC/PLAY head must be connected between this pin and the ground. Switching of REC and PLAY modes is done by Pin9. A load resistor should be connected between this pin and the ground because the input impedance becomes high (several hundred kilohms) in the PLAY mode.
16	REC ADJ	REC gain control A resistance connected between this pin and the ground determines the head bias current in the REC mode. The lower the resistance, the higher the current. A serial combination of a resistance and a capacitance, connected in parallel with the resistance, determines the REC gain.
17	VOX in	VOX amplifier input The preamplifier output at Pin18 must be connected through a resistor and a capacitor to this pin. The impedance between Pin18 and this pin determines the gain, and a resistance between Pin11 and the ground determines the frequency characteristics of the VOX amplifier.
18	Pre out	Preamplifier output Amplified MIC/line preamplifier outputs are output from this pin depending on the statuses of Pin7 (preamplifier mute) and Pin8 (MIC/line switching).
19	Pre NF	Preamplifier inverse input Resistors and a capacitor connected between this pin and Pin18 and 12 determine the preamplifier gain. The input impedance at this pin is several hundred kilohms.
20	ALC DET	ALC detection control A 240kΩ resistor and a 4.7μF capacitor connected in parallel between this pin and the ground control ALC detection sensitivity.

■ Pin Descriptions (cont.)

Pin No.	Symbol	Description
21	LIN in	Line preamplifier input Line receiver signals are input through a capacitor and a resistor to this pin, and then amplified to be output from Pin18. The statuses of Pins7 and 8 enable or disable the signals. The input impedance with ALC OFF is 10k Ω .
22	MIC in	MIC preamplifier input MIC signals are input through a capacitor and a resistor to this pin, and then amplified to be output from Pin18. The statuses of Pins7 and 8 enable or disable the signals. The input impedance with ALC OFF is 10k Ω .
23	PRE V _{CC}	Preamplifier internal regulated supply voltage output This pin should be grounded through a 220 μ F capacitor. The output voltage is typically 4.2V. The output can be used as an ECM bias current source.
24	PRE GND	Preamplifier ground This is the ground pin for the preamplifier circuits.

■ Pin Descriptions

Pin No.	Description	Pin No.	Description
1	Loudspeaker amplifier power supply input	13	Equalizer amplifier output
2	Loudspeaker amplifier output	14	Equalizer amplifier inverting input
3	Loudspeaker amplifier ground	15	To the REC/PLAY head
4	Loudspeaker amplifier inverse input	16	REC gain control
5	Loudspeaker amplifier non-inverting input	17	VOX amplifier input
6	Loudspeaker amplifier mute control	18	Preamplifier output
7	Preamplifier mute control	19	Preamplifier inverting input
8	MIC/line preamplifier switching	20	ALC detection control
9	REC/PLAY switching	21	Line preamplifier input
10	VOX output	22	MIC preamplifier input
11	VOX detection control	23	Preamplifier internal regulated supply voltage output
12	Internal reference supply voltage output	24	Preamplifier ground

■ Block Diagram Showing the Logic of Amplifiers

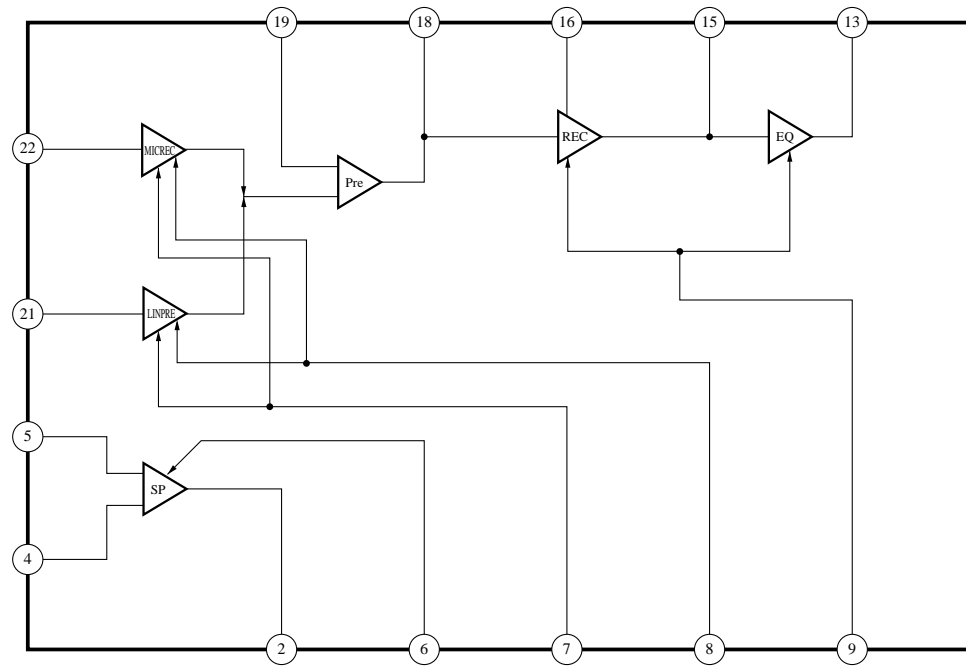

1. Loudspeaker amplifier mute

6 SP MUTE	SP POWER
H	ON
L	OFF

2. REC/PLAY switching

9 PLAY/REC	REC	EQ
H	OFF	ON
L	ON	OFF

3. Preamplifiers switching

9 PRE AMP	iMIC/LIN	MIC PRE AMP	LIN PRE AMP
H	—	OFF	OFF
L	H	OFF	ON
L	L	ON	OFF

Application Circuit

