

AN6783S

IC for long interval timer

■ Overview

The AN6783S is an IC designed for a long interval timer. It is oscillated by using the external resistor and capacitor, and the oscillation frequency divided by a 15-stage F.F. is provided as the output.

It is frequency divider type, so that a long interval timer can be constructed by using a capacitor with small capacitance.

■ Features

- Oscillation frequency dispersion of IC itself is small ($\pm 5\%$)
- Oscillation frequency can be checked by $1/2 f_{OSC}$ monitor terminal
- Wide operating supply voltage range (3.2 V to 18 V)
- Small consumption current (3 mA typ.)

■ Applications

- Timer

■ Block Diagram

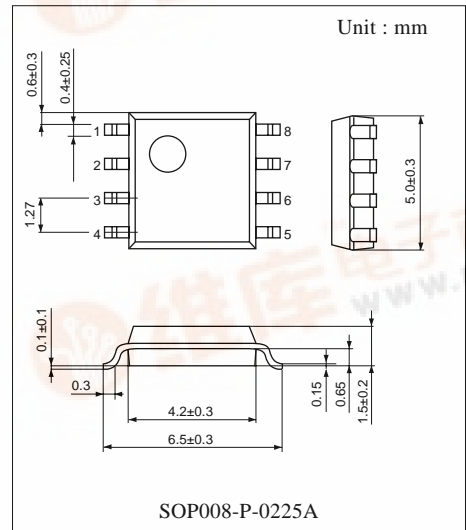
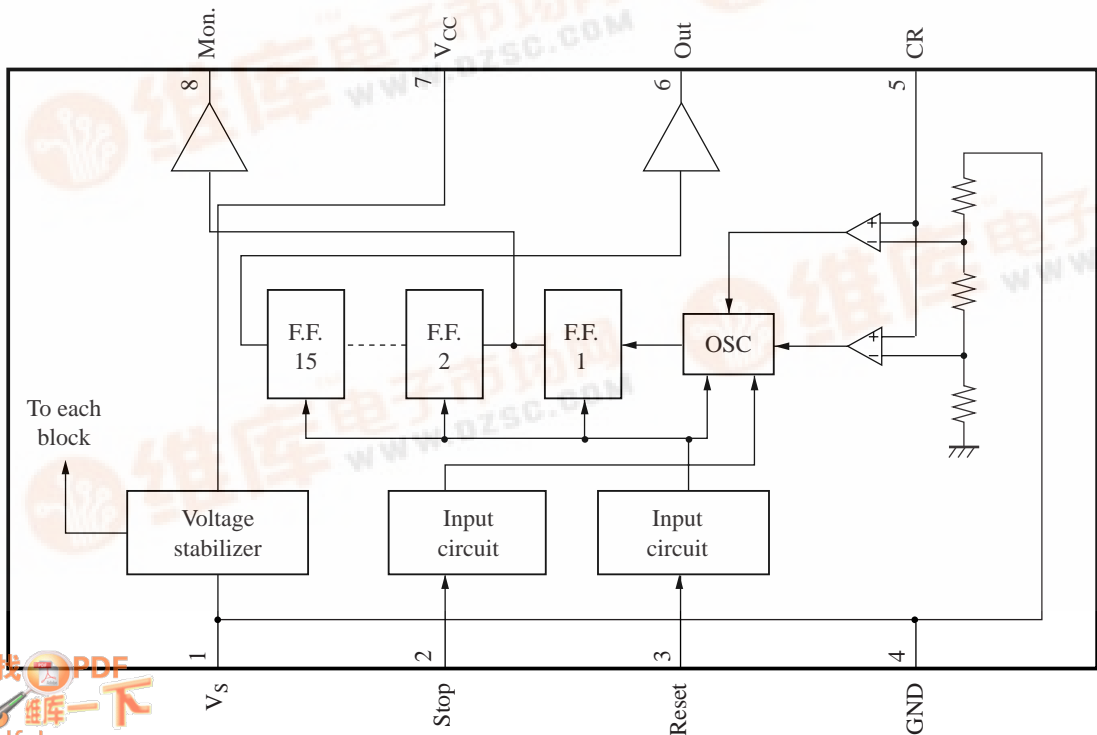

■ Pin Descriptions

Pin No.	Symbol	Description
1	V_S	Reference voltage
2	Stop	Oscillation stop input
3	Reset	Reset input
4	GND	Grounding
5	CR	C and R connection
6	Out	Output
7	V_{CC}	Supply voltage
8	Mon.	Monitor pin

■ Absolute Maximum Ratings

Parameter	Symbol	Rating	Unit
Supply voltage	V_{CC}	20	V
Supply current	I_{CC}	7	mA
Power dissipation	P_D	140	mW
Operating ambient temperature *	T_{opr}	-35 to +85	°C
Storage temperature *	T_{stg}	-55 to +125	°C
Stop terminal voltage	V_{STOP}	0 to 18	V
Reset terminal voltage	V_{RESET}	0 to 18	V
CR terminal voltage	V_{CR}	0 to 3	V
Out terminal current	I_{OUT}	-15 to +15	mA

Note) 1. Do not apply external currents or voltages to any pins not specifically mentioned.

For circuit currents, '+' denotes current flowing into the IC, and '-' denotes current flowing out of the IC.

2. *: Except for the operating ambient temperature and storage temperature, all ratings are for $T_a = 25^\circ\text{C}$.

■ Recommended Operating Range

Parameter	Symbol	Range	Unit
Supply voltage	V_{CC}	3.2 to 18.0	V

■ Electrical Characteristics at $T_a = 25^\circ\text{C}$

Parameter	Symbol	Conditions	Min	Typ	Max	Unit
Quiescent supply current	I_{CC}	$V_{CC} = 5\text{ V}$	2.0	4.0	5.0	mA
Internal reference voltage	V_S	$V_{CC} = 5\text{ V}, I_S = -3\text{ mA}$	2.40	2.55	2.70	V
High-level input current	I_{IH}	$V_{CC} = 18\text{ V}, V_{IH} = 18\text{ V}$	—	—	10	μA
Low-level input current	I_{IL}	$V_{CC} = 18\text{ V}, V_{IL} = 0\text{ V}$	-100	—	—	μA
High-level out terminal voltage	V_{OH}	$V_{CC} = 18\text{ V}, I_{OH} = -10\text{ mA}$	14.0	16.0	18.0	V
Low-level out terminal voltage	V_{OL}	$V_{CC} = 3.2\text{ V}, I_{OL} = -10\text{ mA}$	—	—	0.4	V

■ Electrical Characteristics at $T_a = 25^\circ\text{C}$ (continued)

Parameter	Symbol	Conditions	Min	Typ	Max	Unit
High-level Mon. terminal voltage	V_{MH}	$V_{CC} = 18\text{ V}$	17.8	—	18.0	V
Low-level Mon. terminal voltage	V_{ML}	$V_{CC} = 3.2\text{ V}$	—	—	0.4	V
Oscillation frequency precision	f_{OSC}	$V_{CC} = 5\text{ V}$, $R_T = 1\text{ k}\Omega$, $C_T = 0.1\text{ }\mu\text{F}$	9.0	9.5	10.0	kHz
Oscillation frequency fluctuation with supply voltage	Δf_V	$V_{CC} = 5\text{ V}$, 3.2 V to 18.0 V	-5.0	—	5.0	%
High-level input voltage	V_{IH}	$V_{CC} = 5\text{ V}$	2.0	—	—	V
Low-level input voltage	V_{IL}	$V_{CC} = 5\text{ V}$	—	—	0.8	V

• Design reference data

Note) The characteristic values below are theoretical values for designing and not guaranteed.

The data show the changing amount within $T_a = -35^\circ\text{C}$ to $+85^\circ\text{C}$ when the values at $T_a = 25^\circ\text{C}$ is taken as the reference.

Parameter	Symbol	Conditions	Min	Typ	Max	Unit
Oscillation frequency-temperature dependency	Δf_T	$V_{CC} = 5\text{ V}$, $R_T = 1\text{ k}\Omega$, $C_T = 0.1\text{ }\mu\text{F}$	-5.0	—	5.0	%

■ Terminal Equivalent Circuits

Pin No.	Equivalent circuit	Description	I/O	DC voltage
1	—	V_S : Stabilized power supply output terminal. Reference voltage source for oscillation circuit.	O	2.55 V
2		Stop : Oscillation stop input terminal. Only the oscillation circuit stops when this terminal becomes low-level. (F.F. is not cleared) When not used, the terminal should be open or connected to V_{CC} .	I	—

■ Terminal Equivalent Circuits (continued)

Pin No.	Equivalent circuit	Description	I/O	DC voltage
3		<p>Reset :</p> <p>Reset input terminal.</p> <p>F.F. is reset when the terminal becomes low-level and is set in the initial state.</p> <p>When not used, the terminal should be open or connected to V_{CC}.</p> <p>The reset is applied by rising V_{CC} from a voltage below 0.8 V (power-on reset function).</p>	I	—
4	—	<p>GND :</p> <p>Grounding terminal.</p>	—	0 V
5		<p>CR :</p> <p>C and R connection terminal.</p> <p>The oscillation period is determined by an external resistor and capacitor.</p> <p>When applying a pulse to this terminal from the outside, the voltage should be within the range of 0 V to 3 V.</p>	—	0.7 V to 1.8 V
6		<p>Out :</p> <p>Output terminal.</p> <p>A frequency which is 1/32768 of the oscillation frequency is outputted.</p> <p>Use with an output current within ± 10 mA.</p>	O	<p>High-level</p> <p>$V_{CC} - 1.4$ V</p> <p>Low-level</p> <p>< 0.4 V</p>
7	—	<p>V_{CC} :</p> <p>Supply voltage terminal.</p>	—	—
8		<p>Mon. :</p> <p>Oscillation frequency monitor terminal.</p> <p>The output is given from the first stage of F.F. and a frequency which is 1/2 of the oscillation frequency f_{OSC} is outputted. If not used, the terminal should be open. This terminal is provided for connecting probe such as oscilloscope. Use it with an output current under 100 μA.</p>	O	<p>High-level</p> <p>V_{CC}</p> <p>Low-level</p> <p>< 0.4 V</p>

■ Usage Notes

Pay attention to the following matters in order to prevent the destruction during the use and to increase the reliability ;

1. In the application circuit example, the calculated value by the theoretical equation for timer interval calculation and the characteristics curve vary depending on the precision of the time interval capacitor used in the actual set. Take such matter of the above into consideration.

Also, the proportional constant α depends on the kinds and characteristics of the time interval resistor and time interval capacitor.

Make a final confirmation with the finished products.

In the case when a high precision is required, adjust the value by using a variable resistor as the time interval resistor.

2. Use a time interval resistor in the range of 1 k Ω to 1 M Ω , and a time interval capacitor in the range of 0.1 μ F to 100 μ F which is polyester or tantalum electrolytic capacitor with a small $\tan\delta$ value.
3. Connect a capacitor (1 μ F to 10 μ F) to the V_S terminal in order to protect the IC from an external noise and stabilize its operation.
4. If turning on power again after an extremely short-time power supply off state during the normal operation, be careful that there may be a case that the automatic reset (power-on reset) fails due to a residual potential of the external capacitance.
5. Take measures against noise in order to avoid the malfunction caused by the external noise. Pay attention to the noise from an external source especially at setting a long interval time.
6. When connecting a plunger or relay to the output circuit, connect a diode to the both ends of coil in order to protect the IC from the counter-electromotive force generated after the circuit is turned off .
7. Do not short circuit the V_S terminal with V_{CC} terminal in order to avoid malfunction.

■ Main Characteristics

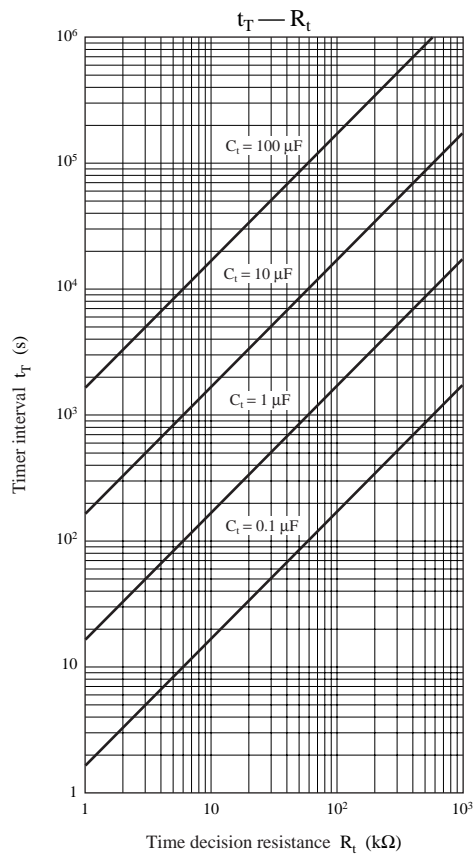
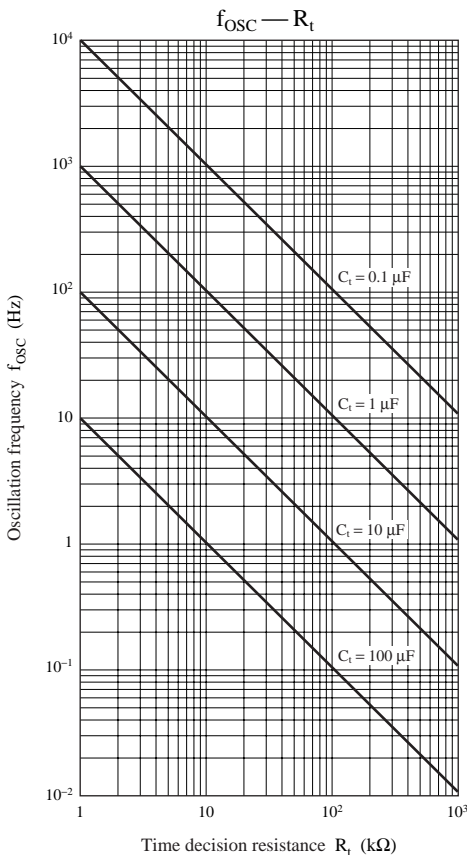

■ Main Characteristics (continued)

$V_{OH} - I_{OH}$

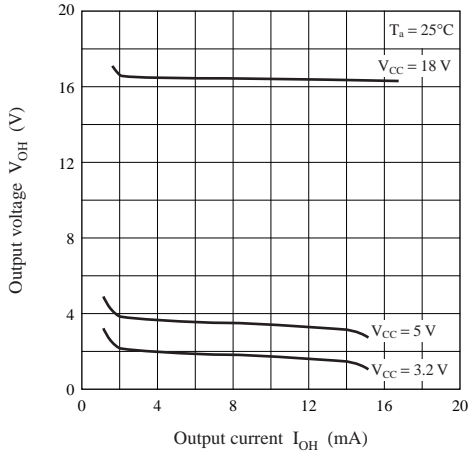

$V_{OL} - I_{OL}$

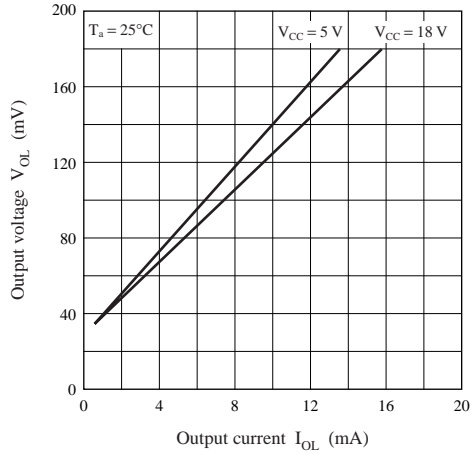

$f_{OSC} - T_a$

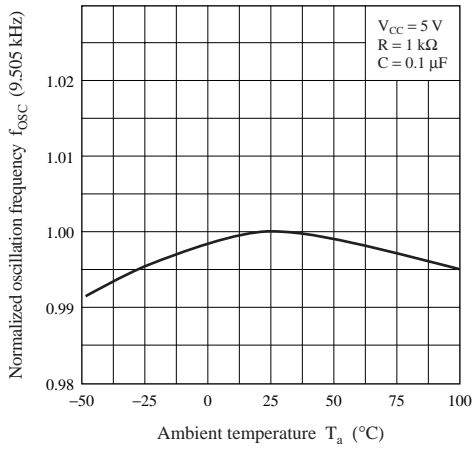

$I_{CC} - V_{CC}$

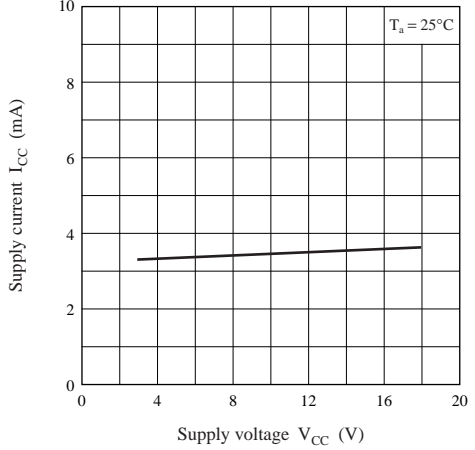

$I_{CC} - T_a$

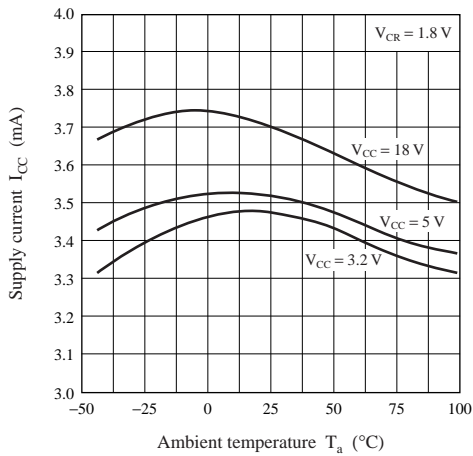

$V_S - T_a$

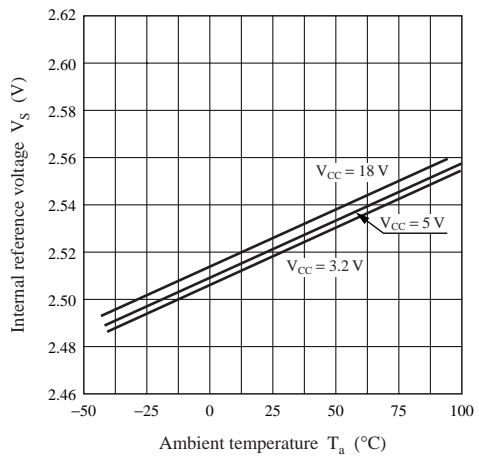

■ Application Circuit Example

The AN6783S can be used as an integrator-type timer and as a long time timer using a stop pin. It is also usable as a ultra low frequency oscillator.

1. Ultra low frequency oscillation circuit

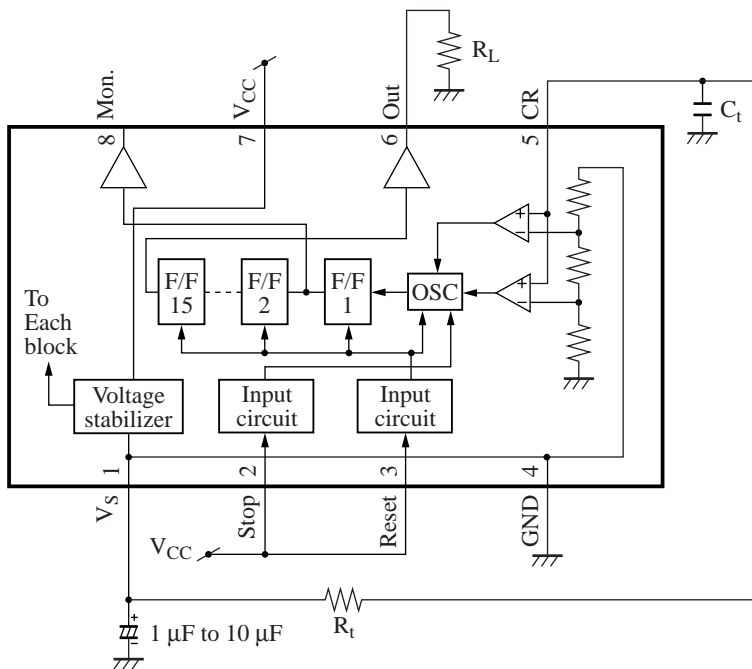

- Oscillation period
 $t_{0(S)} \approx 0.947R_t (\Omega) \cdot C_t (F)$
- Output period
 $t_{2(S)} \approx t_0 \times 32768$
 $\approx 31.03R_t (k\Omega) \cdot C_t (\mu F)$

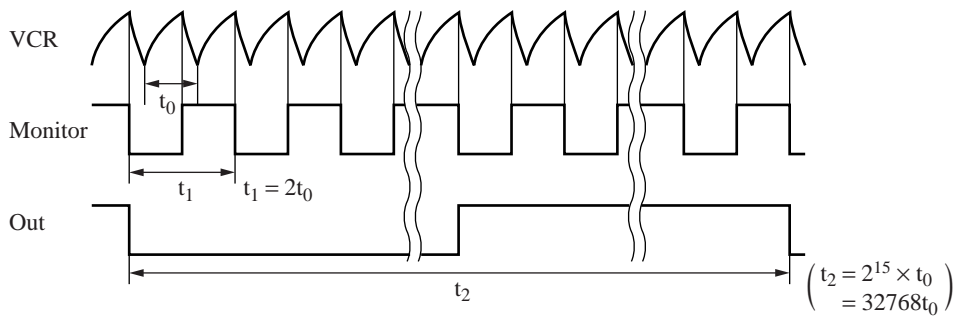

■ Application Circuit Example (continued)

2. Timer

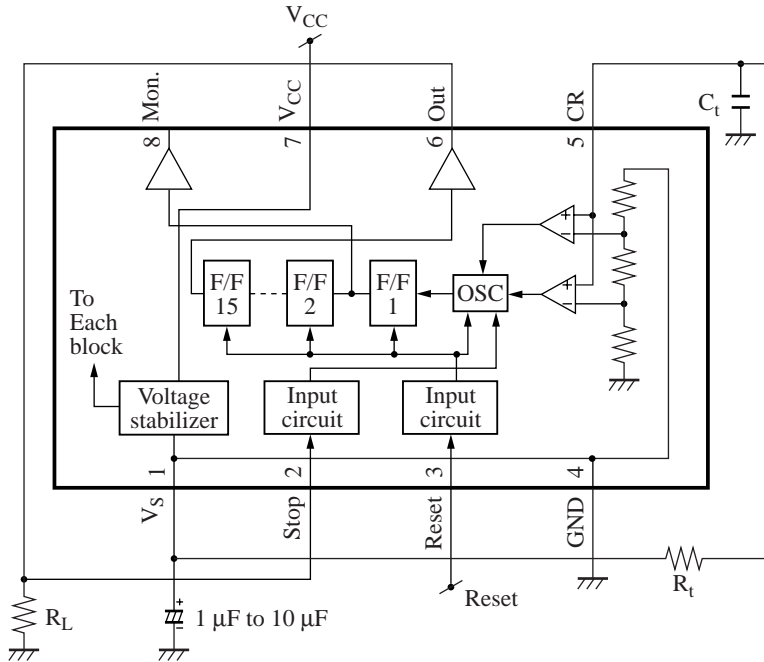

• Timer interval

$$t_T = 16384t_0$$

$$= 16384 \times 0.947R_t (\Omega) \cdot C_t (F)$$

$$\approx 15.52R_t (k\Omega) \cdot C_t (\mu F)$$

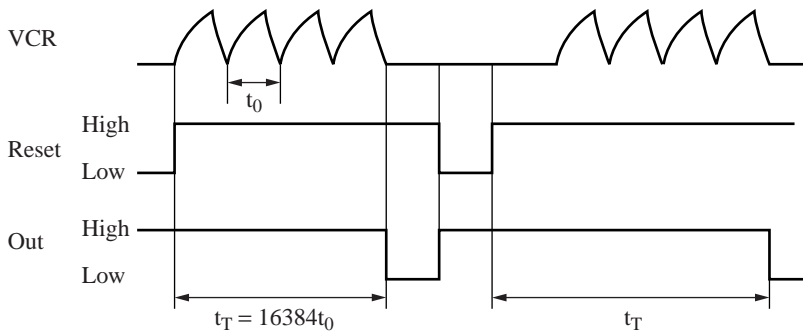

Note) For AN6784 and AN6785, above descriptions can be applied to with regard to their same pin functions.

■ Application Circuit Example (continued)

3. Quick check of the operation of the equipment which uses AN6783S

- 1) Input to pin 5 a higher frequency than the frequency with C and R, and the timer's time becomes short. Since a capacitor of big capacitance is attached at pin 5 at this moment, use a power amplifier which has an output of a totem pole type. (If the output of a pulse generator is large enough, it is not necessary.) But be careful to keep an input waveform of 1.8 V or less.
- 2) Place R_{TEST} in parallel with R_t only at the test to lower the resistance, and an oscillation frequency may be high and a timer interval can be shortened.

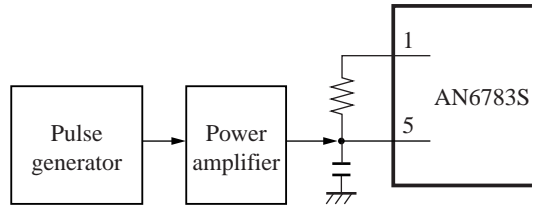

Oscillation waveform of pin 5
 1.8 V
 0.7 V

The waveform shows a pulse with a peak-to-peak voltage of 1.8 V and a minimum voltage of 0.7 V.

