

ICs for Audio Common Use

Panasonic

AN7118S

Low Voltage Dual 35mW Audio Power Amplifier Circuits (BTL 300mW)

Overview

The AN7118S is the ICs designed for power amplifier of low voltage operated compact radio and stereo tape recorder. Stereo operation is enabled due to incorporating two amplifiers on one chip. Miniaturization of cassette and high integration is realized due to SOP package.

Features

- Low voltage operation : $V_{CC} = 1.8V$ to $4.5V$
- Reduced voltage operation is available.
- Low pop noise when supply voltage is switched ON and OFF
- Stereo drive of 4Ω (speaker) to 32Ω (headphone) load is possible.

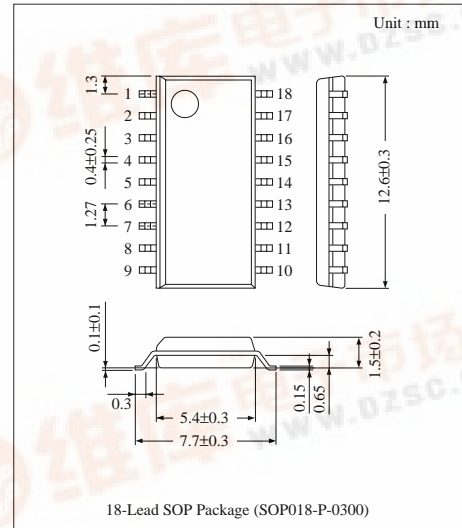

Block Diagram

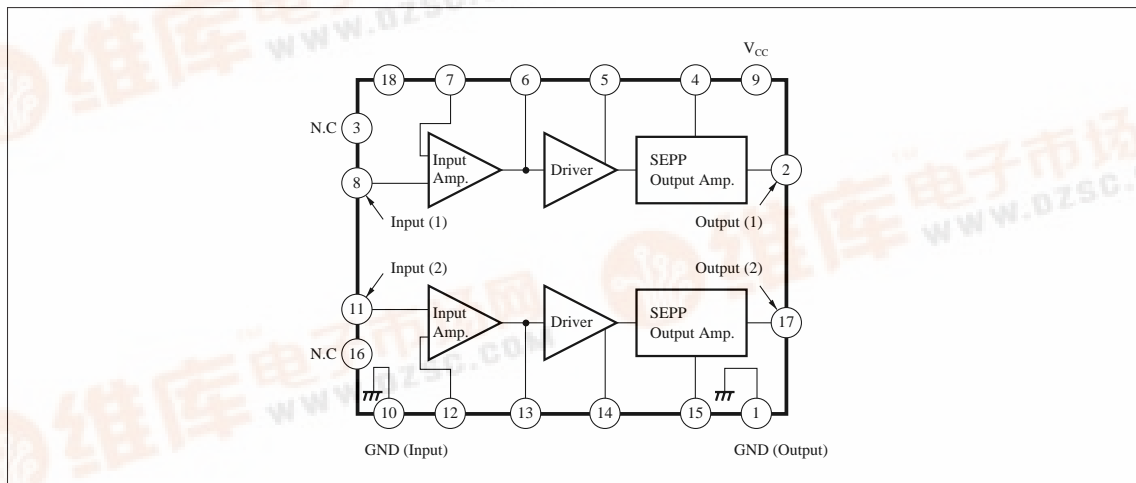

■ Pin Descriptions

| Pin No. | Pin Name | Pin No. | Pin Name |
|---------|--------------------|---------|--------------------|
| 1 | GND (Output) | 10 | GND (Input) |
| 2 | Output Ch.1 | 11 | Input Ch.2 |
| 3 | NC | 12 | N.F.B |
| 4 | Bootstrap | 13 | Phase Compensation |
| 5 | Phase Compensation | 14 | Phase Compensation |
| 6 | Phase Compensation | 15 | Bootstrap |
| 7 | N.F.B | 16 | NC |
| 8 | Input Ch.1 | 17 | Output Ch.2 |
| 9 | V _{CC} | 18 | Ripple Filter |

■ Absolute Maximum Ratings (Ta= 25°C)

| Parameter | Symbol | Rating | Unit |
|-------------------------------|------------------|--------------|------|
| Supply Voltage | V _{CC} | 4.5 | V |
| Supply Current | I _{CC} | 1 | A |
| Power Dissipation | P _D | 400 | mW |
| Operating Ambient Temperature | T _{opr} | - 20 ~ + 75 | °C |
| Storage Temperature | T _{stg} | - 50 ~ + 125 | °C |

■ Electrical Characteristics (V_{CC}= 3V, Ta= 25°C)

| Parameter | Symbol | Condition | min. | typ. | max. | Unit |
|---------------------------|-----------------|---|------|------|------|------|
| Quiescent Circuit Current | I _{CQ} | V _i = 0mV | — | 13 | 18 | mA |
| <DUAL (f=1kHz)> | | | | | | |
| Voltage Gain | G _V | V _i = 1.5mV, R _L = 32Ω | 45 | 47 | 49 | dB |
| Maximum Output | P _O | THD= 10%, R _L = 32Ω × 2ch. | — | 33 | — | mW |
| Total Harmonic Distortion | THD | V _i = 1.5mV, R _L = 32Ω × 2ch. | — | 0.3 | 1 | % |
| Output Noise Voltage | V _{no} | R _g = 10kΩ, DIN Audio Filter | — | 0.5 | 1 | mV |
| Input Resistance | R _i | | — | 20 | — | kΩ |
| Ripple Rejection Ratio | RR | V _{CC} = 3V± 200mV, f= 100Hz | — | 35 | — | dB |

■ Application Circuit

AN7118S Dual Circuit

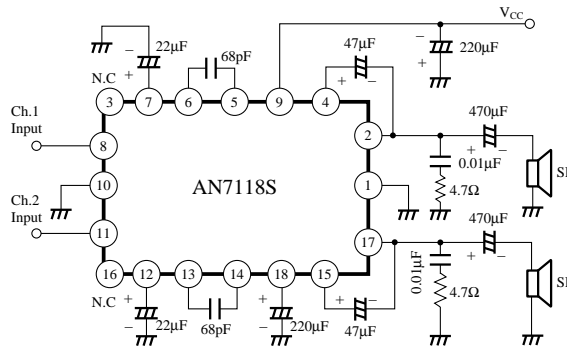

■ Characteristics Curve

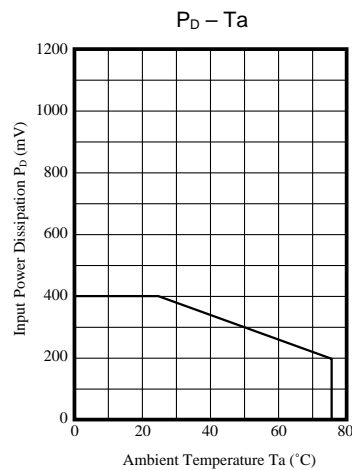

■ Supplementary Explanation of IC Characteristics

- Not necessary for input coupling capacitor. Input electric potential is about 0 bias, using PNP Tr for input stage.
- One chip dual amp. (Stereo operation)
- Battery operation is possible at 1.8V to 4.5V
- Decreased voltage operation is available, and suitable for a long battery operation.
- Load impedance can be driven from 4Ω, which makes it possible to use for both speaker and headphone.
- Small shock noise at power ON and OFF.