

AN7191NZ

Dual 20 W BTL audio power amplifier

Overview

The AN7191NZ is an audio power IC developed for the sound output of car audio (dual 20 W). It is incorporating various protective circuits to protect the IC from destruction by GND-open short circuit to GND and power supply surge which are the important subject of power IC protection, so the IC will largely contribute to a high reliability design of equipment. Also, it is incorporating a perfect muting circuit which is free from shock noise, so that a shock noise design under the set transient condition can be made easily using together with its standby function.

Features

- BTL 20 W × 2-channel (4 Ω), $G_V = 34$ dB
- Built-in various protection circuits (thermal protection, short circuit to V_{CC} and short circuit to GND, V_{CC} -open short circuit to V_{CC} , GND-open short circuit to GND, overvoltage and supply surge, and ASO, etc.)
Especially, the supply surge breakdown voltage is 100 V or more.
GND open breakdown voltage is 16 V or more.
- Built-in standby function (free from shock noise at standby on/off)
- Built-in muting function
Free from shock noise at mute-on/off.
Adapting attenuator method so that abnormal sound due to waveform deformation is not generated.
Attack time, recovery time are 50 ms or less.
- Reduction in external components
It eliminates the need for NF and BS electrolytic capacitors.
Muting function is not required, and power supply choke coil is unnecessary.
- Provided with beep sound input pin
- 2 Ω load guaranteed

Applications

- Car audio

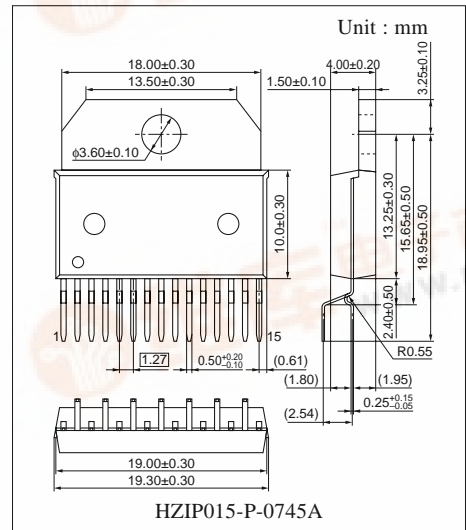

■ Block Diagram

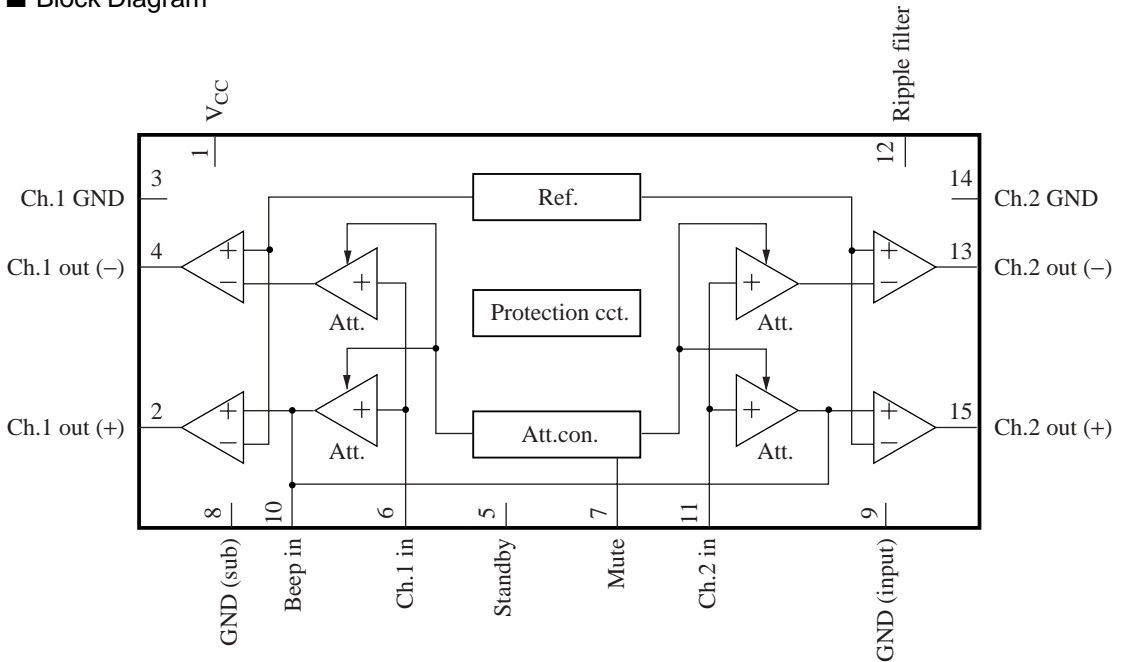

■ Pin Descriptions

Pin No.	Description	Pin No.	Description
1	Power supply	9	Grounding (input)
2	Ch.1 output (+)	10	Beep sound input
3	Grounding (output ch.1)	11	Ch.2 input
4	Ch.1 output (-)	12	Ripple filter
5	Standby	13	Ch.2 output (-)
6	Ch.1 input	14	Grounding (output ch.2)
7	Muting	15	Ch.2 output (+)
8	Grounding (sub)		

■ Absolute Maximum Ratings

Parameter	Symbol	Rating	Unit
Supply voltage ^{*2}	V _{CC}	25	V
Peak supply voltage ^{*3}	V _{surge}	80	V
Supply current	I _{CC}	9.0	A
Power dissipation ^{*4}	P _D	59	W
Operating ambient temperature ^{*1}	T _{opr}	-30 to +85	°C
Storage temperature ^{*1}	T _{stg}	-55 to +150	°C

Note) *1 : T_a = 25°C except power dissipation, operating ambient temperature and storage temperature.

*2 : Without signal

*3 : Time = 0.2 s

*4 : T_a = 85°C

■ Recommended Operating Range

Parameter	Symbol	Range	Unit
Supply voltage	V_{CC}	8.0 to 18.0	V

■ Electrical Characteristics at $V_{CC} = 13.2$ V, freq. = 1 kHz, $T_a = 25^\circ\text{C}$

Parameter	Symbol	Conditions	Min	Typ	Max	Unit
Quiescent current	I_{CQ}	$V_{IN} = 0$ mV, $R_L = 4 \Omega$	—	120	250	mA
Standby current	I_{STB}	$V_{IN} = 0$ mV, $R_L = 4 \Omega$	—	1	10	μA
Output noise voltage *1	V_{NO}	$R_g = 4.7$ k Ω , $R_L = 4 \Omega$	—	0.22	0.5	mV[rms]
Voltage gain 1	G_{V1}	$V_{IN} = 40$ mV, $R_L = 4 \Omega$	32	34	36	dB
Total harmonic distortion 1	THD_1	$P_o = 0.5$ W, $R_L = 4 \Omega$	—	0.07	0.4	%
Maximum output power 1	P_{O1}	$THD = 10\%$, $R_L = 4 \Omega$	16	18	—	W
Ripple rejection ratio *1	RR	$R_L = 4 \Omega$, $R_g = 4.7$ k Ω , $V_r = 1$ V[rms], $f_r = 1$ kHz	60	72	—	dB
Channel balance	CB	$V_{IN} = 40$ mV, $R_L = 4 \Omega$	—	0	1	dB
Cross-talk *1	CT	$V_{IN} = 40$ mV, $R_L = 4 \Omega$, $R_g = 4.7$ k Ω	55	65	—	dB
Output offset voltage	V_{OFF}	$R_g = 4.7$ k Ω , $R_L = 4 \Omega$	-250	0	250	mV
Muting effect *1	MT	$V_{IN} = 40$ mV, $R_L = 4 \Omega$	70	82	—	dB
Input impedance	Z_i	$V_{IN} = \pm 0.3$ V _{DC}	22	28	35	k Ω
Voltage gain 2	G_{V2}	$V_{IN} = 40$ mV, $R_L = 2 \Omega$	32	34	36	dB
Total harmonic distortion 2	THD_2	$P_o = 0.5$ W, $R_L = 2 \Omega$	—	0.1	0.5	%
Maximum output power 2	P_{O2}	$THD = 10\%$, $R_L = 2 \Omega$	16	24	—	W
Shock noise *2	V_S	$R_L = 4 \Omega$, $R_g = 4.7$ k Ω , $V_{MUTE} = 5$ V, $V_{STB} = \text{on/off}$, 50Hz HPF-on	-100	0	100	mV ^[p-0]
Total harmonics distortion 3	THD_3	$V_{IN} = 10$ mV, $f_{IN} = 20$ kHz, $R_g = 4.7$ k Ω , $R_L = \infty$	—	0.10	0.5	%

Note) *1 : Measurement using a bandwidth 15 Hz to 30 kHz (12 dB/OCT) filter.

*2 : For $V_{STB} = \text{on/off}$, change over the standby terminal by the voltages of 0 V and 5 V at the time shown in the right.

Standby terminal voltage

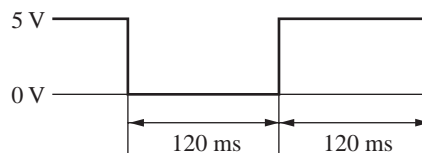

■ Terminal Equivalent Circuits

Pin No.	Equivalent circuit	Description	DC voltage
1	—	Power supply connection pin	13.2 V
2		Ch.1 output pin (+) : Ch.1 positive-phase output pin.	6.6 V
3	—	GND (Output) : Grounding pin for ch.1 output.	0 V
4		Ch.1 output pin (-) : Ch.1 reverse-phase output pin.	6.6 V
5		Standby control pin : Standby changeover pin threshold voltage approx. 2.1 V.	—
6		Ch.1 input pin : Ch.1 input signal applied pin input impedance 30 kΩ.	0 mV to 10 mV
7		Mute control pin : Mute changeover pin threshold voltage approx. 2.0 V.	—

■ Terminal Equivalent Circuits (continued)

Pin No.	Equivalent circuit	Description	DC voltage
8	—	GND (sub) : Being connected to substrate only.	0 V
9	—	GND (input) : Ground pin for input.	0 V
10		Beep sound input pin : Beep sound signal input pin. Input impedance 10 kΩ.	2.1 V
11		Ch.2 input pin : Ch.2 input signal applied pin. Input impedance 30 kΩ.	1 mV to 10 mV
12		Ripple filter pin : Output current 3 mA to 10 mA.	13.0 V
13		Ch.2 output pin (-) : Ch.2 reverse-phase output pin.	6.6 V
14	—	GND (output) : Ground pin for ch.2 output.	0 V

■ Terminal Equivalent Circuits (continued)

Pin No.	Equivalent circuit	Description	DC voltage
15		Ch.2 output pin (+) : Ch.2 positive-phase output pin.	6.6 V

■ Usage Notes

1. Always attach an outside heat sink when using the chip. Note that, the outside heat sink must be fastened onto a chassis for use.
2. Connect the cooling fin to GND potential.
3. Avoid short circuit to V_{CC} and short circuit to GND, and load short-circuit.
4. The temperature protection circuit will be actuated at $T_j =$ approx. 150°C , but it is automatically reset when the chip temperature drops below the above set level.
5. The overvoltage protection circuit starts its operation at $V_{CC} =$ approx. 20 V .
6. Take into consideration the heat radiation design particularly when V_{CC} is set high or when the load is $2\ \Omega$.
7. When the beep sound function is not used, open the beep sound input pin (pin 10) or connect it to pin 9 with around $0.01\ \mu\text{F}$ capacitor.
8. Connect only pin 9 (ground, signal source) to the signal GND of the amplifier in the previous stage. The characteristics such as distortion, etc. will improve.

■ Technical Information

- $P_D - T_a$ curves of HZIP015-P-0745A

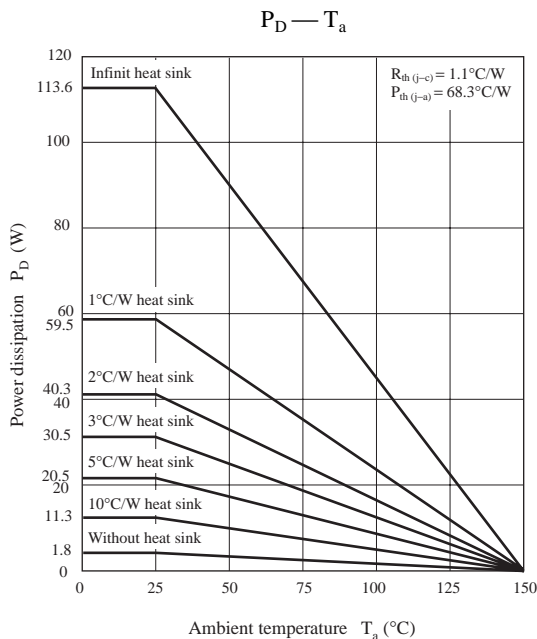

■ Technical Information (continued)

[1] Main characteristics

$P_O - V_{CC}$

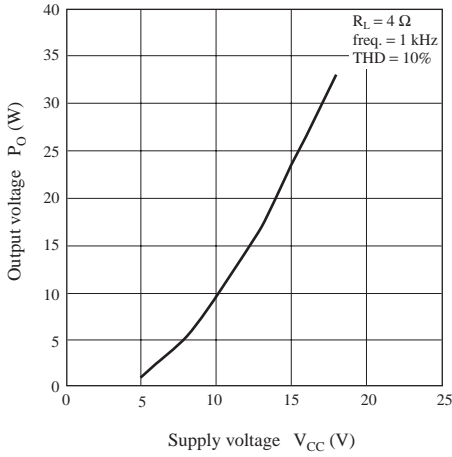

$P_C, I_{CC} - P_O$

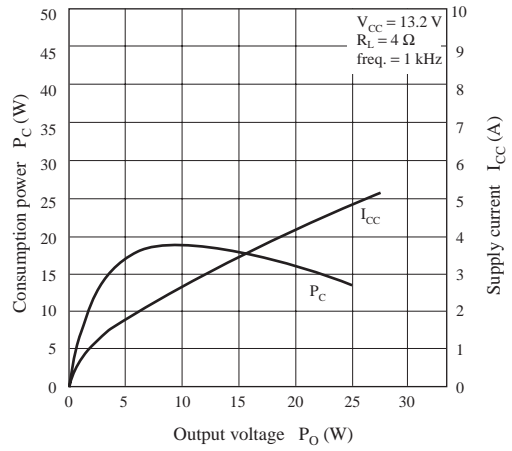

$P_O, THD - V_{IN} (R_L = 4 \Omega)$

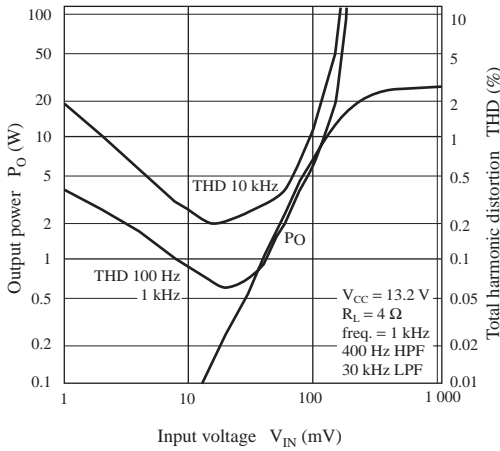

$P_O, THD - V_{IN} (R_L = 2 \Omega)$

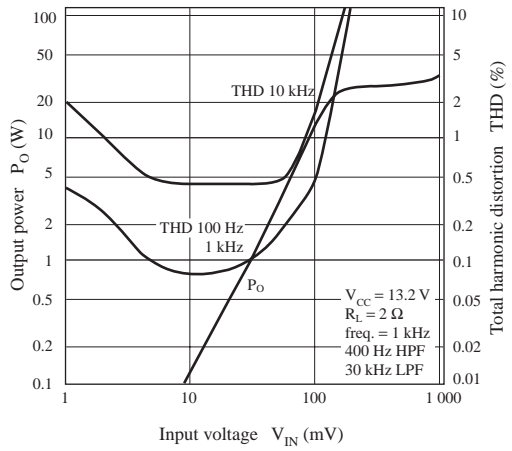

$G_V, P_O - \text{freq.}$

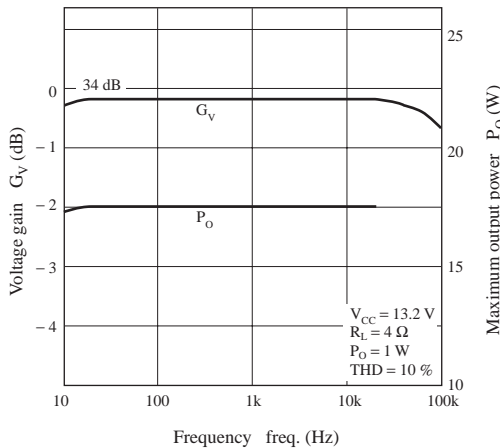

THD — freq.

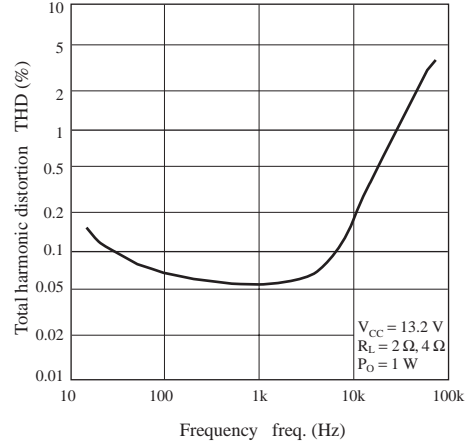

■ Technical Information (continued)

[1] Main characteristics (continued)

$G_V - V_{CC}$

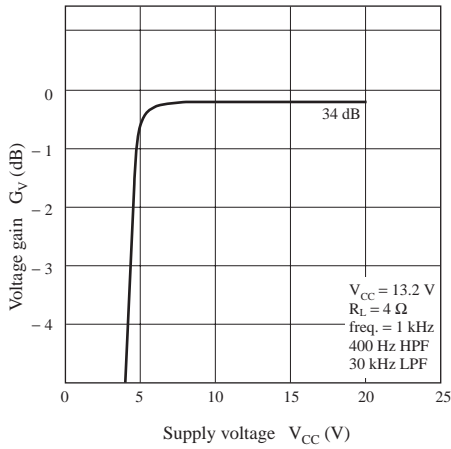

THD — V_{CC}

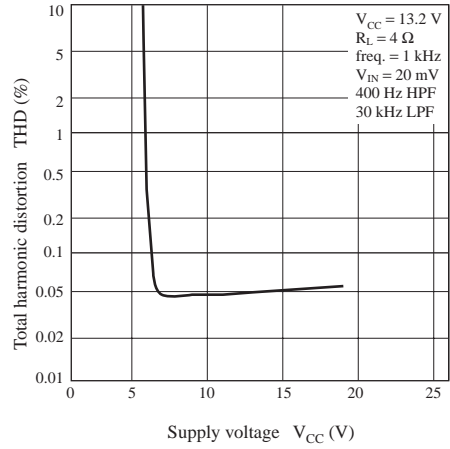

$V_{NO} - R_g$

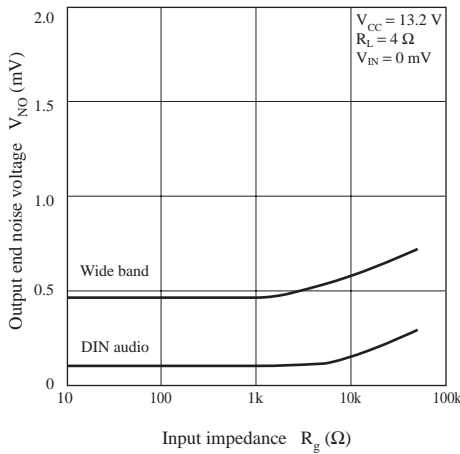

$V_{NO} - V_{CC}$

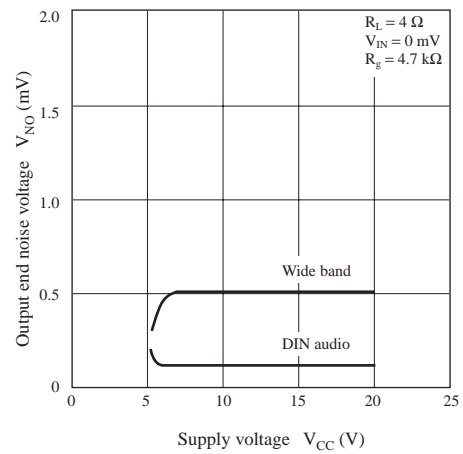

RR — V_r

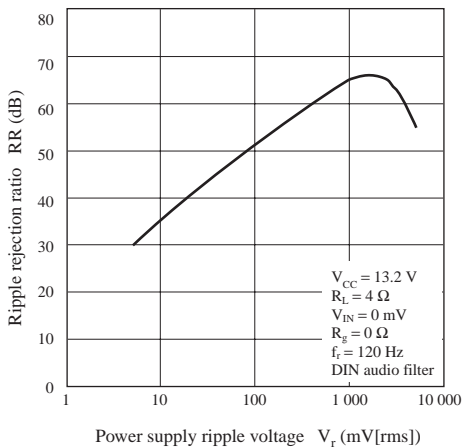

RR — f_r

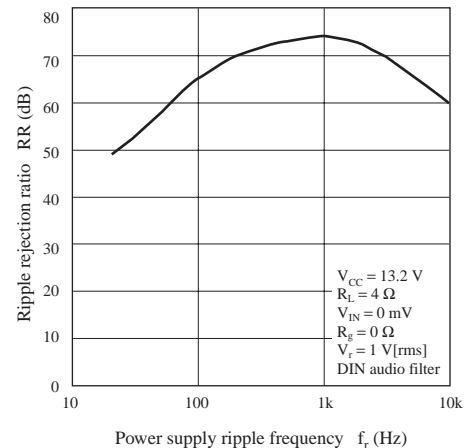

■ Technical Information (continued)

[1] Main characteristics (continued)

RR — V_{CC}

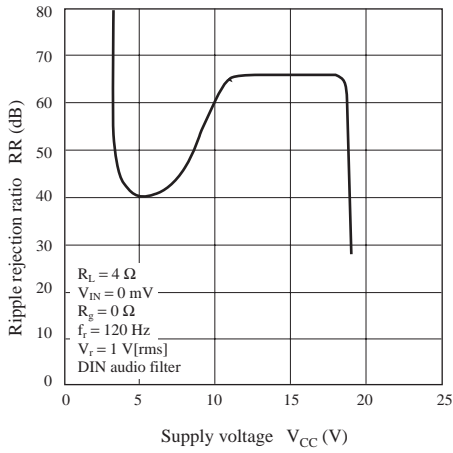

CT — V_{IN}

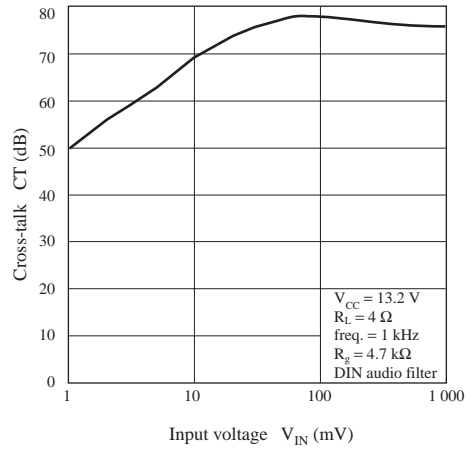

CT — freq.

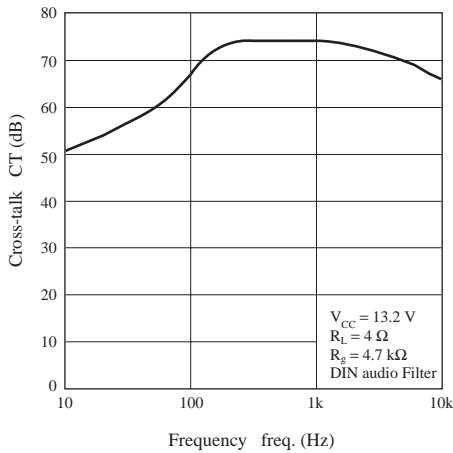

CT — V_{CC}

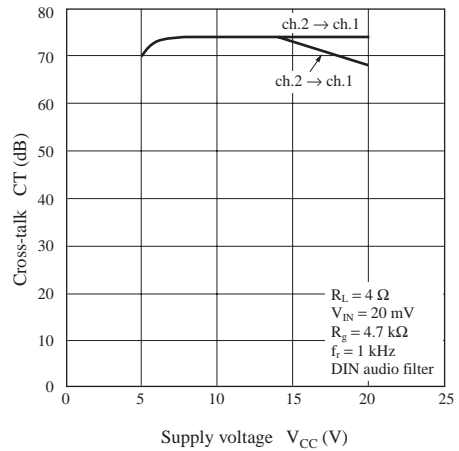

I_{CQ} — V_{CC}

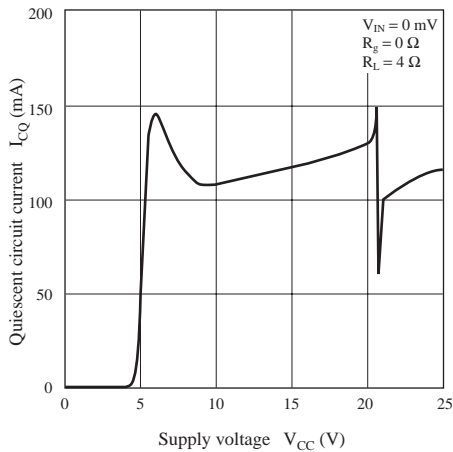

I_{STB} — V_{CC}

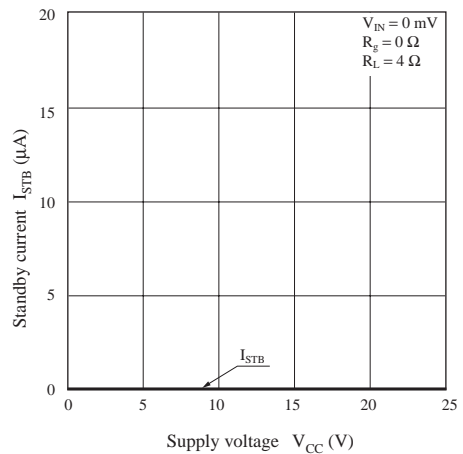

■ Technical Information (continued)

[1] Main characteristics (continued)

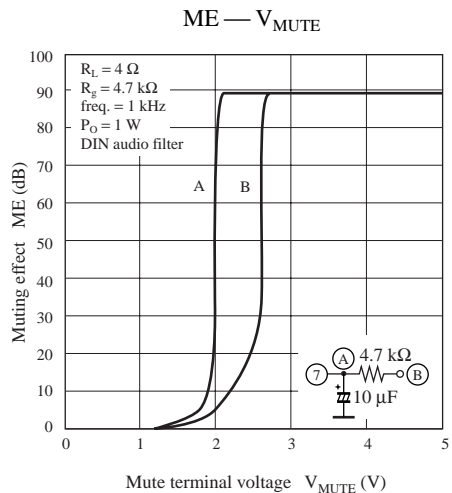
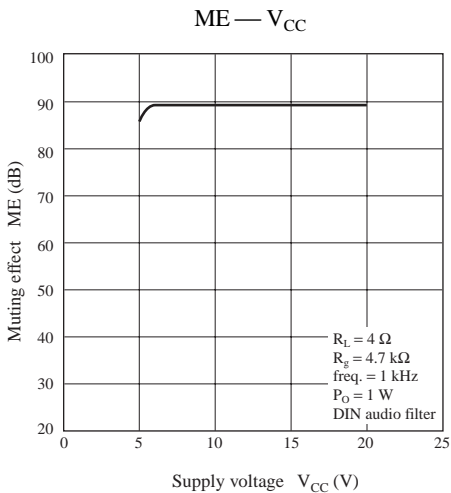
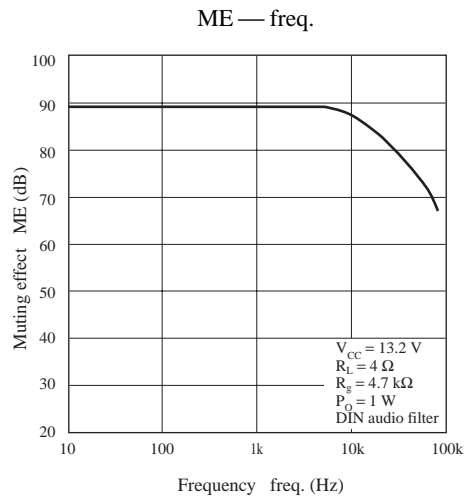
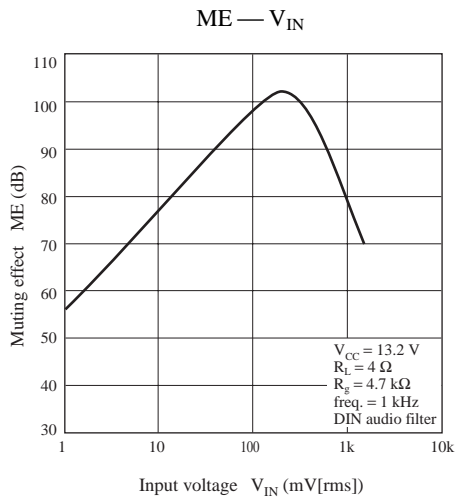
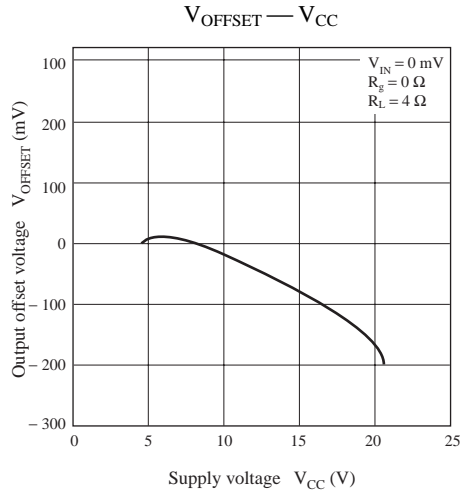
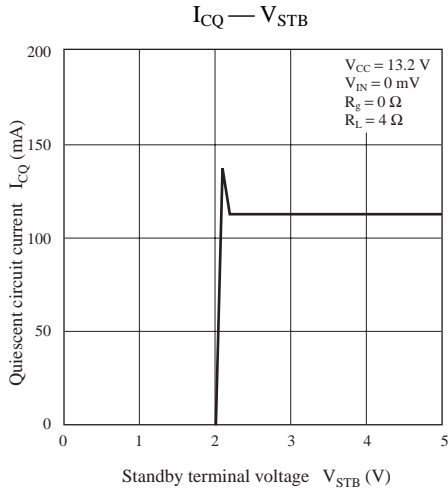

■ Technical Information (continued)

[2] Application note

1. Standby function

- 1) The power can be turned on or off by making pin 5 (standby terminal) high or low.
- 2) The standby terminal has threshold voltage of approx. 2.1 V, however, it has temperature dependency of approx. - 6 mV/°C. The recommended range of use is shown in table 1.

Terminal state	Terminal voltage	Power
Open	0 V	Standby state
Low	0 V to 1.0 V	Standby state
High	Higher than 3 V	Operating state

Table 1

- 3) The internal circuit of standby terminal is as shown in figure 1. When the standby terminal is high, the current approximately expressed by the following equation will flow into the circuit.

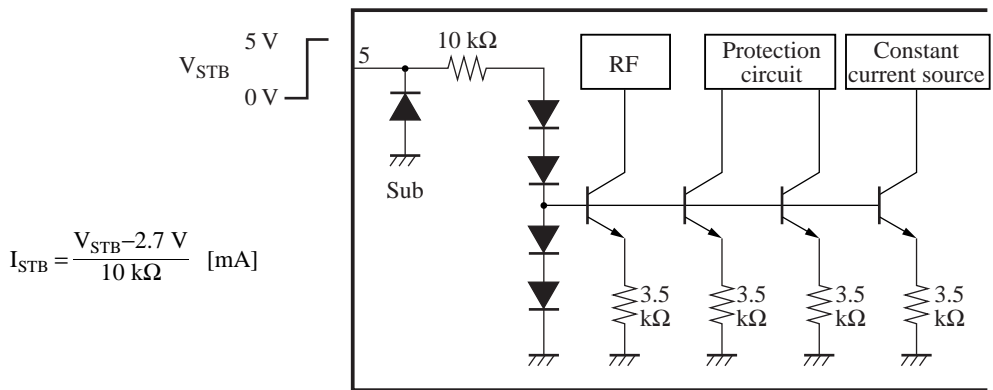

$$I_{STB} = \frac{V_{STB} - 2.7 \text{ V}}{10 \text{ k}\Omega} \text{ [mA]}$$

Figure 1

- 4) A power supply with no ripple component should be used for the control voltage of standby terminal.

2. Oscillation countermeasures

- 1) In order to increase the oscillation allowance, connect a capacitor and a resistor in series between each output terminal and GND as shown in figure 2.
- 2) The use of polyester film capacitor having a little fluctuation with temperature and frequency is recommended as the 0.22 μF capacitor for oscillation prevention.

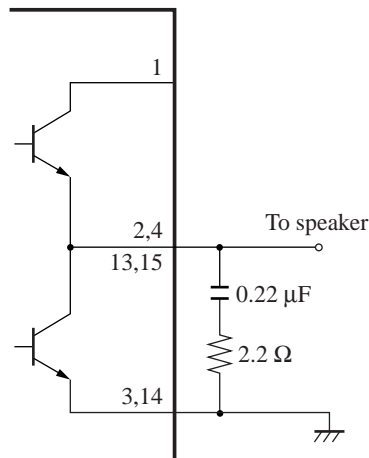

Figure 2

■ Technical Information (continued)

[2] Application note (continued)

3. Input terminal

- 1) The reference voltage of input terminal is 0 V. When the input signal has a reference voltage other than 0 V potential, connect a coupling capacitor (of about several μF) for DC component cut in series with the input terminal. Check the low-pass frequency characteristics to determine the capacitance value.
- 2) 10 k Ω or less of signal source impedance R_g can reduce the output noise voltage.
- 3) The output offset voltage fluctuates when the signal source impedance R_g is changed. A care must be taken when using the circuit by directly connecting the volume to the input terminal. In such a case, the use of coupling capacitor is recommended.
- 4) If a high frequency signal from tuners enters the input terminal as noise, insert a capacitor of approx. 0.01 μF between the input terminal and input GND.

When a high frequency signal is inputted, malfunction of protective circuits may occur.

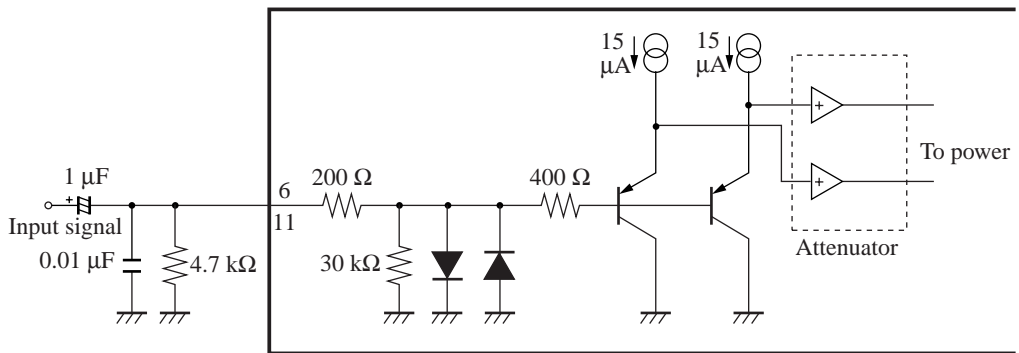

Figure 3

4. Ripple filter

- 1) In order to suppress the fluctuation of supply voltage, connect a capacitor of approx. 33 μF between RF terminal (pin 12) and GND.
- 2) Relation between RR (ripple rejection ratio) and a capacitor
The larger the capacitance of a ripple filter is, the better the ripple rejection becomes.
- 3) Relation between the rise time of circuit and a capacitor
The larger the capacitance of a ripple filter is, the longer the time from the power-on (standby : high) to the sound release becomes.
- 4) The DC voltage of output terminal is approximately the middle point of the ripple filter terminal voltage.
- 5) The internal circuit of ripple filter terminal is as shown in figure 4 and the charge current is approx. 3 mA to 10 mA.

■ Technical Information (continued)

[2] Application note (continued)

4. Ripple filter (continued)

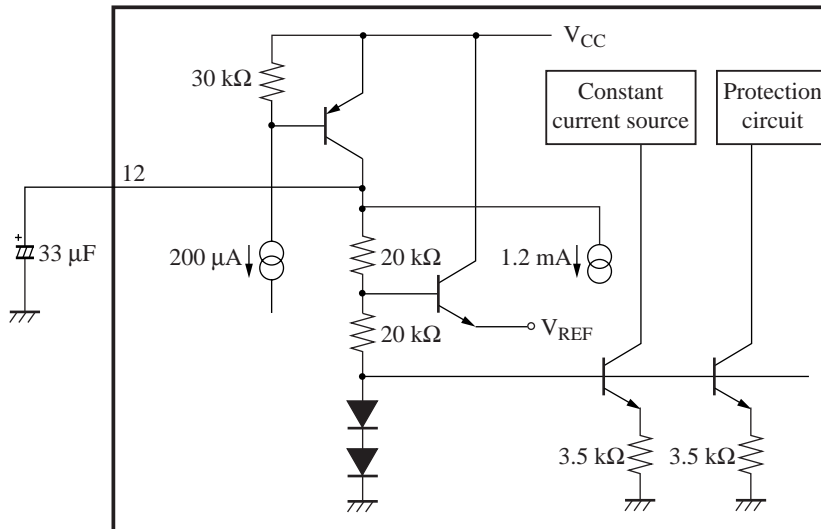

Figure 4

- 6) After power off (STB-low), it takes about 10 seconds or less for the total circuit current to become the standby current (10 μ A or less). In order to reduce the inspection time at the set, insert the resistor of approx. 47 k Ω between the ripple filter terminal and GND. This can shorten the time to reach the standby current.

5. GND terminal

- 1) Be sure to short-circuit each GND terminal of pin 3, pin 8, pin 9 and pin 14 at the outside of the IC when use.
- 2) For each GND terminal, the one-point earth, referenced to the GND connection point of electrolytic capacitor between the supply terminal and GND, is most effective for reducing the distortion. Even in the worst case, ground pin 8, pin 9 of input GND separately from all the other GND terminals.

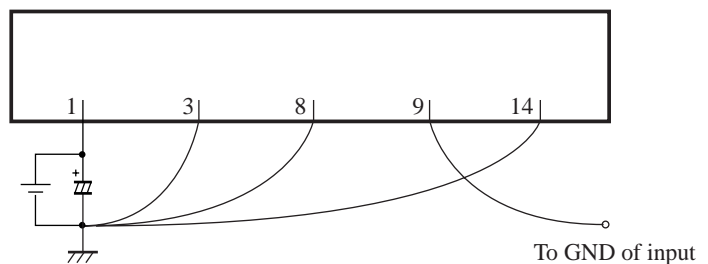

Figure 5

- 3) Each GND terminal is not electrically short-circuited inside. Only pin 8 is connected with the substrate.
 - 4) Pin 9 is input signal GND. Connect only pin 9 with Pre-GND.
- #### 6. Cooling fin
- 1) The radiation fin is not connected with GND terminal by using Au wire. Only pin 8 is electrically connected through the substrate.
 - 2) Always attach an outside heat sink to the cooling fin. The cooling fin must be fastened onto a chassis for use. Otherwise, IC lead failure may occur.
 - 3) Do not give the cooling fin any potential other than the GND potential. Otherwise, it may cause breakdown.
 - 4) Connection of the cooling fin with GND can reduce the incoming noise hum. (It is not necessary to connect with GND in use, but connect with the power GND when connect with GND.)

■ Technical Information (continued)

[2] Application note (continued)

7. Shock noise

1) STB on/off

No shock noise is released. However, the changeover switch of the standby terminal may make a slight shock noise. In such a case, insert a capacitor of approx. 0.01 μF between the standby terminal and GND.

2) Mute on/off

No shock noise is released. Refer to the section on the mute function.

8. Mute function

1) The mute-on/off is possible by making pin 7 (the muting terminal) high or low.

2) The muting circuit is as shown in figure 6. The amplifier gain including attenuator block is given in the following equation :

$$G_V = \frac{I_1}{I_2} \times 50$$

Original gain

From the above equation, the amplifier gain can be made as 0 time by setting I_1 at 0 mA in muting.

3) The threshold voltage of V_{MUTE} is as follows :

Mute-off : Approx. 1 V or less

Mute-on : Approx. 3 V or less

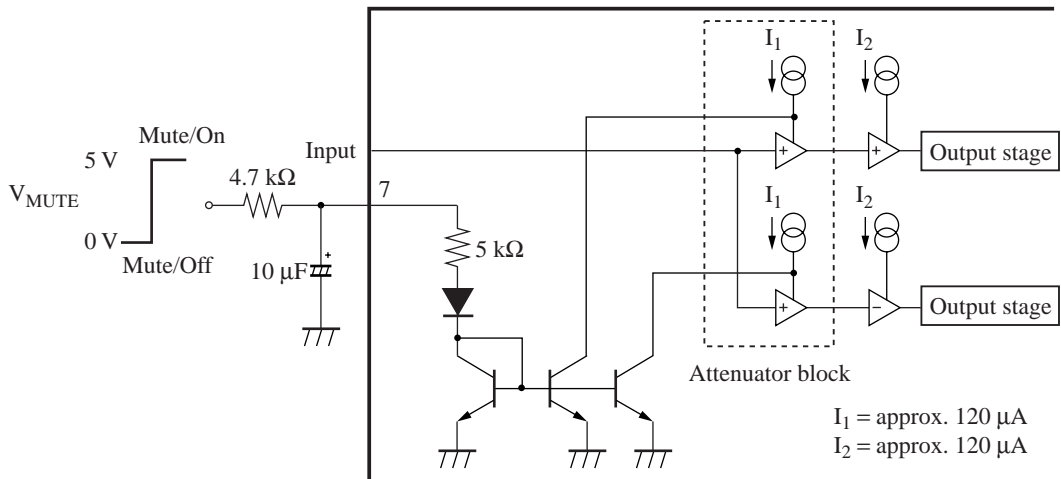

Figure 6

4) Attack time and recovery time can be changed by the external CR of pin 7. For recommended circuits (figure 7. 4.7k Ω , 10 μF), the above mentioned times are as follows :

Attack time : Approx. 30 ms

Recovery time : Approx. 40 ms

However, the control voltage of V_{MUTE} is assumed to be 5 V. When it is not directly controlled by microcomputer (5 V), (13.2 V separate power supply), it is necessary to change CR values because the above times change.

5) When the attack time and recovery time are set at 20 ms or less, pay attention to the IC with larger output offset because it may release the shock noise.

9. Voltage gain

The voltage gain is fixed at 34 dB and can not be changed by the addition of an external resistor.

■ Technical Information (continued)

[2] Application note (continued)

10. Beep sound input function

- 1) The application circuit using the beep sound input is shown in figure 7. Connect the beep signals from the microcomputer to pin 10 via the capacitor C1 for DC cut and the resistor R1 for voltage gain adjustment.
- 2) The voltage gain of beep sound terminal is approx. 3.4 dB. With settings shown in the following drawing, it is approx. -12.7 dB (f = 1 kHz).
- 3) The beep sound is outputted to output terminals pin 2 and pin 15 only.

$$G_v = \frac{600}{1/j\omega C1 + R1 + \frac{20\text{ k} + 1\ 200}{2}} \times 25$$

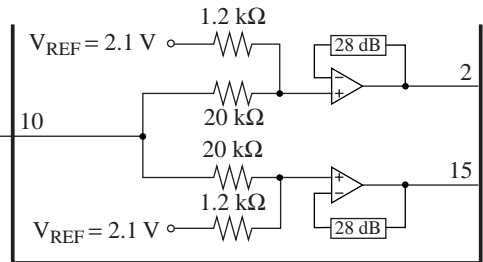

Figure 7

11. Two IC use

Figure 8 shows the application circuit example when two ICs are used :

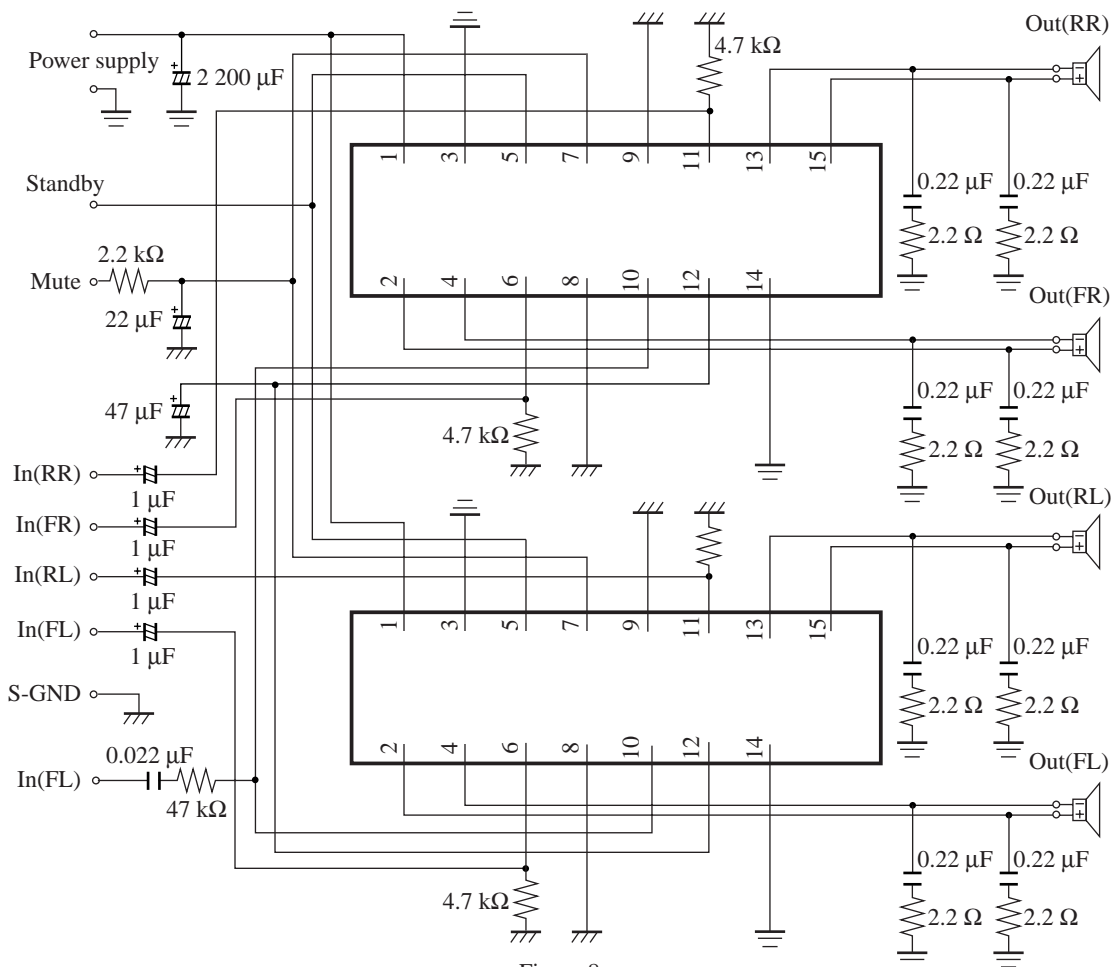

Figure 8

■ Technical Information (continued)

[2] Application note (continued)

11. Two IC use (continued)

1) Supply terminal

Short-circuiting each other, insert an electrolytic capacitor of approx. 2 200 μF into the supply terminals. However, if sufficient characteristics of the ripple rejection can not be obtained, use an even larger capacitor or insert a 2 200 μF capacitor into each IC.

The best sound quality can be obtained by inserting a 2 200 μF capacitor near the terminal of each IC.

2) Standby terminal (pin 5)

The connection of standby terminals with each other does not result in an abnormal operation. Connect with the microcomputer after connecting the standby pins with each other. At that time, the current flowing into the standby terminal is twice larger the current which is described in 1. Standby function.

3) Muting terminal (pin 7)

It does not result in the abnormal operation even if the muting terminals are short-circuited with each other.

The muting time constant changes when two ICs connection is made. If the CR constants are set at twice and 1/2 time respectively, the time constant value becomes as same as the value when 1 IC is used.

4) Beep sound input terminal (pin 10)

Short-circuit between the beep sound input terminals does not result in an abnormal operation.

However, if there is a temperature difference between ICs, there may be a fluctuation of the output offset. In order to avoid such a phenomenon, connect the ICs with each other through a resistor (47 k Ω).

5) Ripple filter terminal (pin 12)

Short-circuit between ripple filter terminals does not result in an abnormal operation.

However, if the standby of each IC is individually controlled, the short-circuiting is not allowed. Use the circuit after connecting a capacitor (33 μF) to each IC.

■ Application Circuit Example

