

ICs for FM/AM Tuner

Panasonic

AN7273, AN7273S

AM Tuner, FM/AM IF Amplifier Circuit

Overview

The AN7273 and the AN7273S are the ICs designed for Hi-Fi stereo tuner. They are functioned with stop signal pin besides the AN7223S function.

Features

- Level meter output (FM-AM common use)
- Stop signal output (for synthesizer tuner)
- AM : including RF amplifier and high sensitivity
- Low power consumption
- Low shock noise level from function switch operation
- Fewer external parts

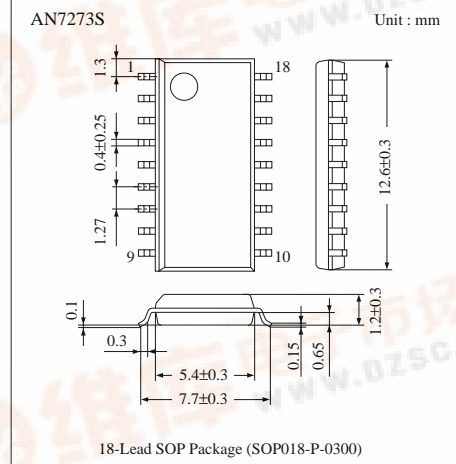
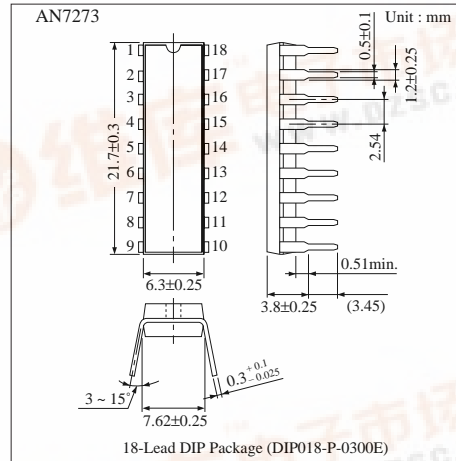

Block Diagram

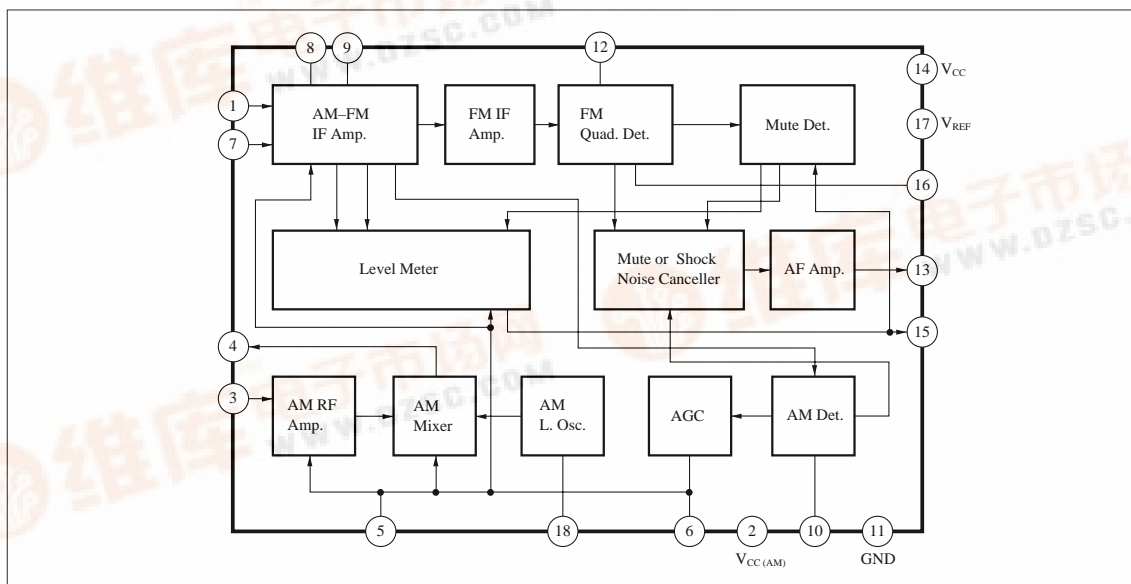

Panasonic



■ Pin Descriptions

Pin No.	Pin Name	Pin No.	Pin Name
1	FM IF Input	10	AM Detection Output
2	AM Supply/Mute Adjustment	11	GND
3	AM RF Input	12	FM Detection Coil
4	AM Mixer Output	13	AF Output
5	AGC Output (2)	14	V _{CC}
6	AGC Output (1)	15	Level Meter Output
7	AM IF Input	16	AFC Output
8	IF By-pass	17	Reference Voltage
9	IF By-pass	18	Local Oscillation Coil

■ Absolute Maximum Ratings (Ta=25°C)

Parameter		Symbol	Rating	Unit
Supply Voltage		V _{CC}	14.4	V
Supply Current		I _{CC}	30	mA
Power Dissipation	AN7273	P _D	317 *1	mW
	AN7273S		210 *2	
Operating Ambient Temperature	AN7273	T _{opr}	-20 ~ + 75	°C
	AN7273S		-20 ~ + 75	
Storage Temperature	AN7273	T _{csg}	-55 ~ + 150	°C
	AN7273S		-55 ~ + 125	

*1 Ta = 25°C, *2 Ta = 75°C

■ Recommended Operating Range (Ta = 25°C)

Parameter	Symbol	Range
Operating Supply Voltage Range	V _{CC (opr)}	3 ~ 12V

■ Electrical Characteristics (V_{CC}= 5V, Ta= 25°C)

Parameter		Symbol	Condition	min.	typ.	max.	Unit
FM	Total Circuit Current	I _{tot}	DC measurement	9	14	20	mA
	Demodulation Output Level	V _O	V _i =80dBμ	75	100	125	mV
	Limiting Sensitivity	V _{i (lim)}	Input at V _O =-3dB	43.5	46	49.5	dBμ
	Muting Sensitivity	V _{i (Mute)}	Input at V _O =more than -20dB	55	64	73	dBμ
	Level Meter Driving Output (1)	V ₁₅₋₁₁	V _i =70dBμ	0.61	0.8	1.1	V
	Level Meter Driving Output (2)	V ₁₅₋₁₁	V _i =100dBμ	1.14	1.26	1.42	V
AM	Total Circuit Current	I _{tot}	DC measurement	8	13	19	mA
	Detection Output Level	V _O	V _i =80dBμ	60	80	100	mV
	Max. Sensitivity	S _{max.}	Input at V _O =10mV	4	9.5	15	dBμ
	Level Meter Driving Output (1)	V ₁₅₋₁₁	V _i =-10dBμ	0	—	130	mV
	Level Meter Driving Output (2)	V ₁₅₋₁₁	V _i =80dBμ	1.12	1.25	1.38	V

Note) Unless otherwise specified, f_i=10.7MHz, Mod.= 22.5kHz, f_m= 400Hz (FM)
f_i=1MHz, Mod.= 30%, f_m= 400Hz (AM)

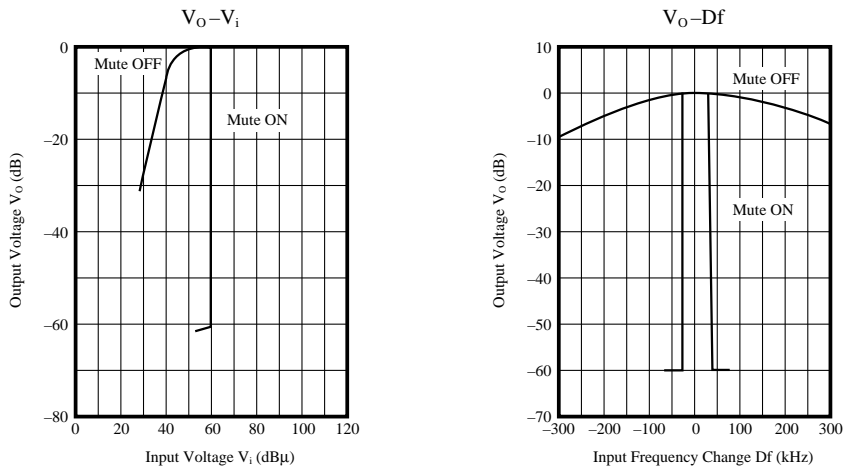
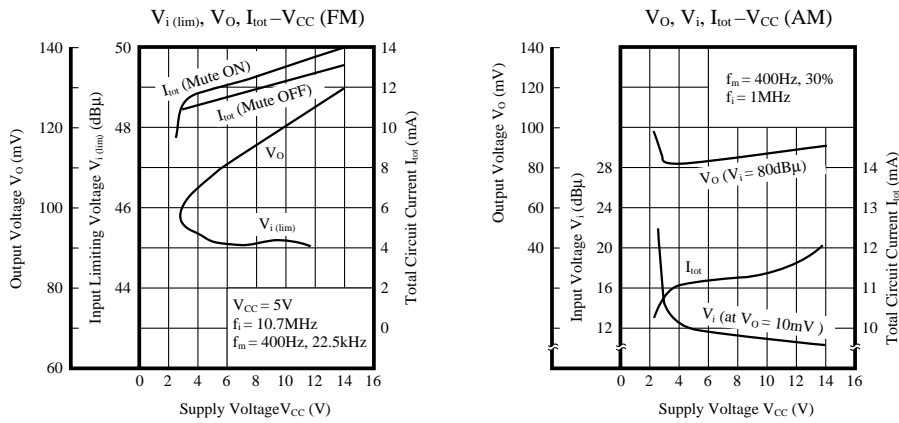
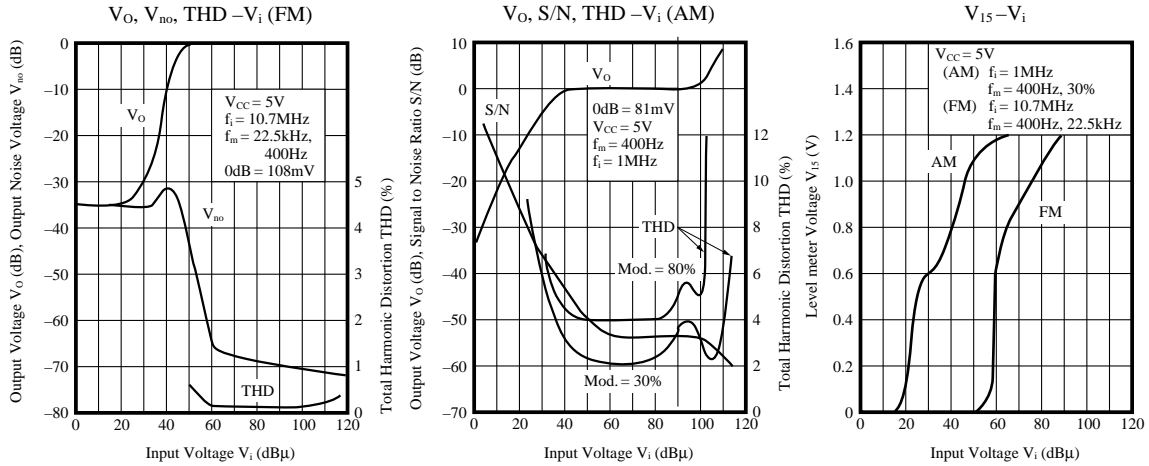

■ Coil Specifications

Symbol	Use, Freq.	Type No.	Maker	Connection Diagram	Number of Turns	Tuning Cap.	Unloaded Q
T ₁	FM Quad. Coil 10.7MHz	ELF-7S752A	Matsushita		1 - 2 8T 2 - 3 5T 4 - 6 3T	100pF	90±20%
T ₂	AM MW Osc. Coil	ELL-7S754	Matsushita		1 - 2 4T 2 - 3 125T 4 - 6 7T	—	95±20%
T ₃	AM Mix. Output 455kHz	EIA-7S802A	Matsushita		3 - 2 35T 6 - 4 10T 2 - 1 19T	1500pF	60±30%

■ Ceramic Filter Specification

Symbol	Use	Type No.	Maker	Center Freq.	Band Width	Loss
CF ₁	AM IF	CFM2-455B	Toko	455kHz	7kHz (-6dB)	2.6dB