

AN7293NFBQ

FM-IF, NC, MPX IC for Car Radio

Overview

The AN7293NFBQ is an IC having FM-IF, NC and MPX function for car radio. A tuner block of car radio can be constructed by this IC and the AN7289NFBQ/NSC.

Features

- A less number of external components is required (8 components reduction compared with our conventional IC)
- Neighboring-station interference characteristics improvement by band-ATC function
- Band-mute on/off function
- DIL package product (the AN7293NSC) is also available

Applications

- Car radios

Block Diagram

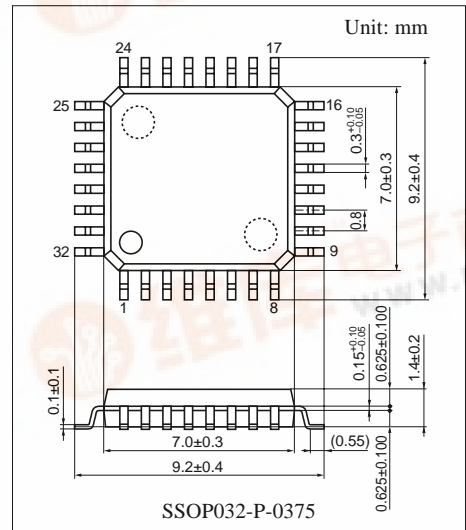
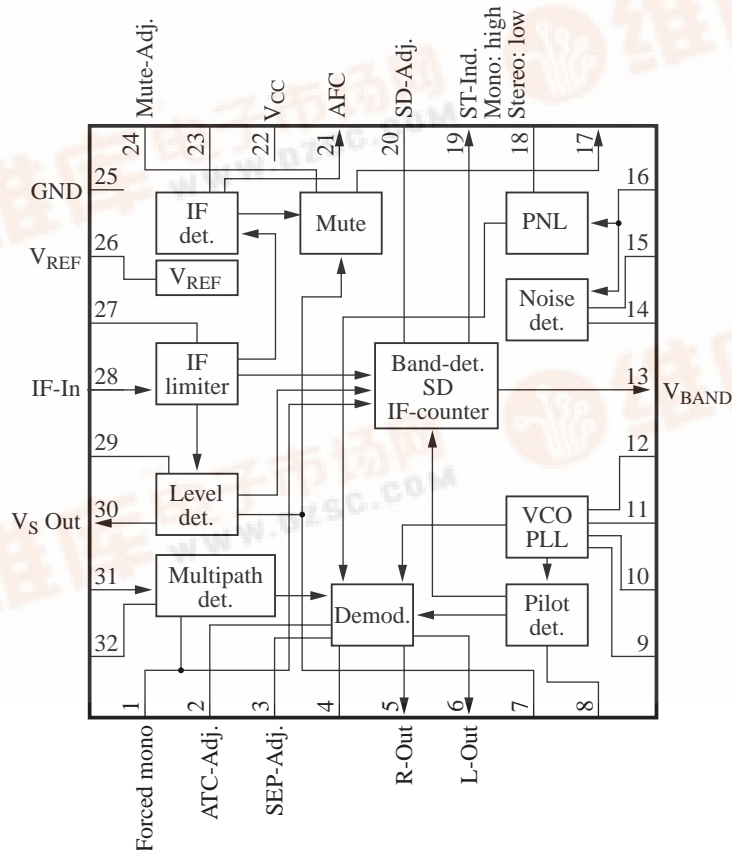

■ Pin Description

Pin No.	Description	Pin No.	Description
1	ASC adjustment/forced monaural	17	Detection output
2	ATC adjustment	18	PNL output hold
3	Separation adjustment	19	SD/FM-IF counter output/stereo indicator
4	ATC low-pass filter	20	SD sensitivity adjustment
5	R-ch. output	21	AFC voltage
6	L-ch. output	22	V _{CC}
7	Mute voltage	23	FM detection
8	Pilot detection low-pass filter	24	Soft mute adjustment
9	PLL low-pass filter	25	GND
10	PLL low-pass filter	26	V _{REF}
11	VCO	27	IF bypass
12	Pilot cancel control low-pass filter	28	IF input
13	Band signal output/band mute SW	29	Control voltage adjustment
14	PNL low-pass filter	30	Control voltage
15	PNL AGC	31	Multi-path noise input
16	PNL input	32	Multi-path detection

■ Absolute Maximum Ratings

Parameter	Symbol	Rating	Unit
Supply voltage	V _{CC}	9.1	V
Supply current	I _{CC}	45	mA
Power dissipation *2	P _D	343.3	mW
Operating ambient temperature *1	T _{opr}	-30 to +80	°C
Storage temperature *1	T _{stg}	-55 to +125	°C

Note) *1: Except for the power dissipation, operating ambient temperature, and storage temperature, all ratings are for T_a = 25°C.

*2: T_a = 80°C

■ Recommended Operating Range

Parameter	Symbol	Range	Unit
Supply voltage	V _{CC}	7.2 to 9.0	V

■ Electrical Characteristics at $T_a = 25^\circ\text{C}$

Unless otherwise specified, $V_{CC} = 8\text{V}$, V_{IN1} is $f = 10.70\text{ MHz}$, Mod. = 1 kHz , 30%

FM modulation stereo input is $L + R = 90\%$ $V_P = 10\%$

Parameter	Symbol	Conditions	Min	Typ	Max	Unit
Control voltage (1)	V_{C1}	Without signal input, pin 30 DC voltage	0.0	0.3	0.9	V
Control voltage (2)	V_{C2}	$V_{IN1} = 40\text{ dB}\mu$, pin 30 DC voltage	0.6	1.3	1.6	V
Control voltage (3)	V_{C3}	$V_{IN1} = 70\text{ dB}\mu$, pin 30 DC voltage	2.4	3.1	3.8	V
Control voltage (4)	V_{C4}	$V_{IN1} = 100\text{ dB}\mu$, pin 30 DC voltage	4.5	5.3	5.8	V
Control voltage (5)	V_{C5}	$V_{C5} = V_{C3} - V_{C2}$	1.8	2.0	2.2	V
Control voltage (6)	V_{C6}	$V_{C6} = V_{C4} - V_{C3}$	1.85	2.05	2.25	V
Output level L-channel	V_{OL}	$V_{IN1} = 70\text{ dB}\mu$, pin 6 AC voltage	85	105	125	mV[rms]
Output level R-channel	V_{OR}	$V_{IN1} = 70\text{ dB}\mu$, pin 5 AC voltage	85	105	125	mV[rms]
Channel balance	CB	$CB = 20 \cdot \log(V_{OL}/V_{OR})$	-1.0	0	1.0	dB
Residual pilot voltage	V_{PC}	$V_P = 10\%$ modulation, $V_{IN1} = 70\text{ dB}\mu$, pin 18 output voltage	—	4	14	mV[rms]
Stereo lamp light up level	LAMP _{ON}	19 kHz modulation, Modulation factor at which pin 19 becomes under 1 V	1.3	4.0	6.3	%
Separation L-channel	Sep _L	$L+R = 90\%$, $V_P = 10\%$ Larger separation value after changing over pin 3 external resistor	25	33	—	dB
Separation R-channel	Sep _R		25	33	—	dB
Capture range	CR	Modulation at $V_P = 6.5\%$ Referred to 19 kHz	± 0.4	± 0.7	—	%
Counter output level (1)	VIF ₁	$V_{IN1} = 100\text{ dB}\mu$, $V_{20} = 2\text{ V}$ pin 19 output voltage	135	155	175	mV[rms]
Counter output level (2)	VIF ₂	$V_{IN1} = 100\text{ dB}\mu$, $V_{20} = 5\text{ V}$ pin 19 output voltage	0	2	5	mV[rms]
Monaural THD (L)	THD _L	V_{IN2} monaural input, 500 mV[0-p] 1 kHz, L-ch. output distortion factor	—	0.1	0.3	%
Monaural THD (R)	THD _R	V_{IN2} monaural input, 500 mV[0-p] 1 kHz, R-ch. output distortion factor	—	0.1	0.3	%
Stereo THD (L)	THD _{STL}	V_{IN2} stereo input, 500 mV[0-p] 1 kHz, L-ch. output distortion factor	—	0.1	0.3	%
Stereo THD (R)	THD _{STR}	V_{IN2} stereo input, 500 mV[0-p] 1 kHz, R-ch. output distortion factor	—	0.1	0.3	%
PNL-AGC voltage (1)	V_{AGC1}	$V_{IN2} =$ Without input pin 15 DC voltage	1.2	1.4	1.7	V
PNL-AGC voltage (2)	V_{AGC2}	$V_{IN2} = 100\text{ mV}$, $f = 100\text{ kHz}$ input Difference from V_{AGC1}	0.1	0.35	0.60	V
Residual noise voltage	V_{NR}	$V_{IN2} =$ (pulse width 10 μs , 1 V[p-p] 1 kHz) L-ch. output	0.0	0.2	0.7	mV[rms]

■ Electrical Characteristics at $T_a = 25^\circ\text{C}$ (continued)

Unless otherwise specified, $V_{CC} = 8\text{V}$, V_{IN1} is $f = 10.70\text{ MHz}$, $\text{Mod.} = 1\text{ kHz}$, 30%

FM modulation stereo input is $L + R = 90\%$ $V_p = 10\%$

Parameter	Symbol	Conditions	Min	Typ	Max	Unit
SD sensitivity	SD_S	V_{IN1} when $V_{20} = 2\text{ V}$, $V_{19} > 2\text{ V}$	70	80	90	$\text{dB}\mu$
SD bandwidth	SD_W	V_{IN} bandwidth when $V_{24} = 2\text{ V}$, and $V_{19} > 2\text{ V}$, $V_{IN1} = 100\text{ dB}\mu$	100	130	160	kHz
Supply current	I_{TOT}	Without input	30	37	44	mA
Limiting sensitivity	V_{LIM}	V_{IN1} input level when pin 5 AC voltage drops by 3 dB	24	32	38	$\text{dB}\mu$
ATC	V_{ATC}	L-ch. output ratio when $V_2 = 2\text{ V}$ and 0 V	7	11	15	dB
Gate pulse width	PW	$V_{IN2} = (\text{pulse width } 1\text{ }\mu\text{s}, 0.3\text{ V}[\text{p-p}]$ 1 kHz) pin 18 output pulse width	16	23	30	μs

• Design reference data

Note) The following characteristics are the reference values for design and not guaranteed values.

Parameter	Symbol	Conditions	Min	Typ	Max	Unit
Stereo lamp turn off level	$LAMP_{OFF}$	Ratio between the modulation factor when pin 19 becomes 2 V or more and $LAMP_{ON}$	2.0	6.0	10.0	dB
AFC offset voltage	V_{AFC}	Without signal input, DC potential difference between pin 21 and pin 26.	-0.1	0.0	0.1	V

Application circuit Example

