

ICs for Cassette, Cassette Deck

**Panasonic**

# AN7353S

## Record Equalizer Amp. for Stereo Cassette Deck

### Overview

The AN7353S is a bipolar IC developed as a record equalizer amp. of analogue cassette deck. Particularly in order to support the automatic adjustment, it incorporates various volume filter circuits and control functions. Also, it has realized great reduction of external parts required.

### Features

- Fine adjustment of equalizer characteristics (frequency characteristics and gain) in medium and high frequency band by DC control
- Volume for total gain adjustment built-in ( $\pm 11\text{dB}$ )
- With pin for low frequency band boost
- Drive circuit for current output built-in

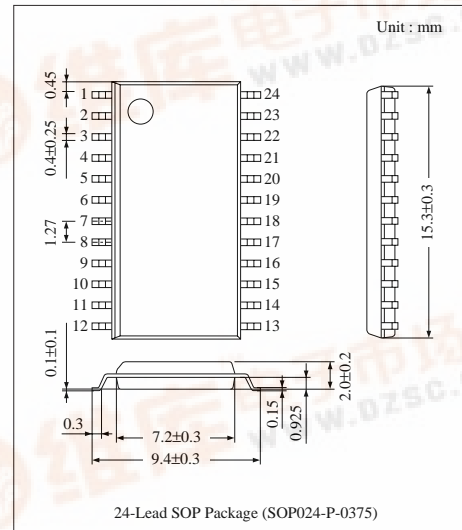

### Block Diagram

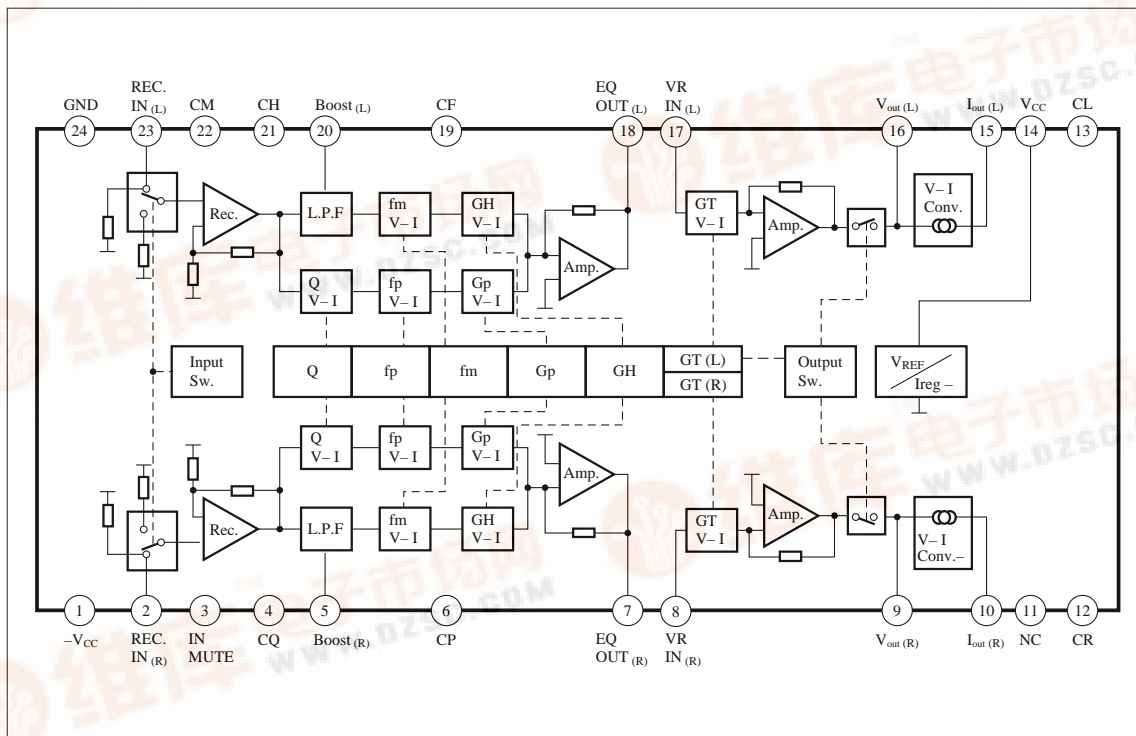

### ■ Absolute Maximum Ratings (Ta=25°C)

Parameter	Symbol	Rating	Unit
Supply Voltage	V <sub>CC</sub>	±6.7	V
Supply Current	I <sub>CC</sub> (+)	26	mA
	I <sub>CC</sub> (-)	23	mA
Power Dissipation	P <sub>D</sub>	521	mW
Operating Ambient Temperature	T <sub>opr</sub>	-25 ~ + 75	°C
Storage Temperature	T <sub>stg</sub>	-55 ~ + 125	°C

### ■ Recommended Operating Range (Ta= 25°C)

Parameter	Symbol	Range
Operating Supply Voltage Range	V <sub>CC</sub>	± 4.5V ~ ± 6.5V

### ■ Electrical Characteristics (V<sub>CC</sub>= ±6V, Ta=25±2°C)

Parameter	Symbol	Condition	min.	typ.	max.	Unit	
Reference Output (EQ Output)	VEQ	f <sub>in</sub> = 400Hz, V <sub>in</sub> = -6dBv	-4	-1.5	+1	dBv	
Medium/High Frequency Band Gain	HIGH	f <sub>in</sub> = 10kHz, V <sub>in</sub> = -12dBv, V <sub>EQ</sub> = 0dB	3.5	5.5	7.5	dB	
	LOW		-8.5	-6.5	-4.5		
High Frequency Band Peak Gain	HIGH	V <sub>in</sub> = -30dBv	16	18	20	dB	
	LOW	V <sub>in</sub> = -18dBv	7	9	11		
High Frequency Band Peak Band Width (10kHz Output)	WIDE	f <sub>in</sub> = 10kHz, V <sub>in</sub> = -18dBv, V <sub>EQ</sub> = 0dB	2	4.5	7	dB	
	NALLOW		-2.5	0	+2.5		
High Frequency Band Peak Frequency Control Voltage	HIGH	f <sub>in</sub> = 35kHz	3.85	4.25	4.65	V	
	LOW	f <sub>in</sub> = 10kHz	1	1.2	1.4		
Volume Amp. Gain (VOL Output)	HIGH	V <sub>in</sub> = -18dBv	16.5	18.5	20.5	dB	
	LOW	V <sub>in</sub> = 0dBv	-5.5	-3.5	-1.5		
Total Harmonics Distortion	VOL	V <sub>in</sub> = -14dBv RL <sub>V</sub> = 10kΩ	—	0.3	0.8	%	
	CULL	V <sub>in</sub> = -14dBv RL <sub>V</sub> = 1kΩ	—	0.3	0.8		
Maximum Output Voltage	VOL	RL <sub>V</sub> = 10kΩ	2.2	3.2	—	V <sub>rms</sub>	
	CULL	RL <sub>V</sub> = 1kΩ	1	1.5	—		
Output Noise Voltage (CURR Output)	VN <sub>(RC)</sub>	R <sub>g</sub> = 0Ω RL <sub>V</sub> = 1kΩ, DIN/AUDIO	—	0.6	2	mV · rms	
Input Muting Attenuation (EQ Output)	IM <sub>(EQ)</sub>	f <sub>in</sub> = 1kHz, 3p : OPEN V <sub>in</sub> = -6dBv	40	—	—	dB	
Output Muting Attenuation (VOL Output)	OM <sub>(RU)</sub>	f <sub>in</sub> = 1kHz, V <sub>CL</sub> = 0.3V V <sub>in</sub> (VR) = 0dBv	60	—	—	dB	
Output Offset Voltage (EQ Output)	V <sub>off</sub> (EQ)	R <sub>g</sub> = 0Ω	-900	—	+500	mV	
Output Offset Current (CURR Output)	V <sub>off</sub> (RC)	RL <sub>V</sub> = 1kΩ RL <sub>V</sub> = 100kΩ	-25	—	+25	μA	
Pulse Noise Current (CURR Output)	VPN <sub>(RC)</sub>	R <sub>g</sub> = 0Ω	-9	—	+9	mV <sub>P-O</sub>	
Muting Control Voltage	Input Side	VIM	Pin3 threshold value voltage (Mute ON voltage)	3.9	—	V <sub>CC</sub>	V
	Output Side	VOM	Pin13 threshold value voltage (Mute ON voltage)	GND	—	0.3	
Consumption Current	I <sub>tot</sub>	No signal	20	23	26	mA	

■ Pin Description

Pin No.	Pin Name	Pin No.	Pin Name
1	Main Circuit -V <sub>CC</sub>	13	Volume Amp. Gain (L ch.)/Output Mute Control
2	Record Amp. Input (R ch.)	14	Main Circuit +V <sub>CC</sub>
3	Record Amp. Input Mute Control	15	Record Amp. Current Output (L ch.)
4	High Frequency Band Peak Band Width Control	16	Record Amp. Voltage Output (L ch.)
5	Low Frequency Band Boost (R ch.)	17	Volume Amp. Input (L ch.)
6	High Frequency Band Peak Gain Control	18	Equalizer Amp. Output (L ch.)
7	Equalizer Amp. Output (R ch.)	19	High Frequency Band Peak Frequency Control
8	Volume Amp. Input (R ch.)	20	Low Frequency Band Boost (L ch.)
9	Record Amp. Voltage Output (R ch.)	21	Medium/High Frequency Band Gain Control
10	Record Amp. Current Output (R ch.)	22	Medium Frequency Band Cutoff Frequency Control
11	NC	23	Record Amp. Input (L ch.)
12	Volume Amp. Gain Control (R ch.)	24	GND

■ Application Circuit

