

AN7500FHQ

Audio signal processing IC for 1.5 V headphone stereo

■ Overview

The AN7500FHQ is a single chip IC optimum for a 1.5 V headphone stereo system including pre-amp., power amp. and Dolby B type noise reduction circuit. Current consumption in a Dolby circuit off mode has been drastically reduced and an operating supply voltage has also been lowered to 0.98 V. Much fewer external components have been realized due to an integration of audio signal processing system into a single chip circuitry in a small outline package and space saving mounting of a set.

■ Features

- Reduction by power consumption of approximately 35% as compared with conventional products, contributing to low power consumption of a set.
- Eliminating the DC/DC converter so far needed for conventional system due to 1.5 V single power supply, and reducing approx. 40% of external components. This contributes to space saving in a set.
- Built-in standby switch to reduce consumption current considerably.

■ Applications

- Headphone stereo

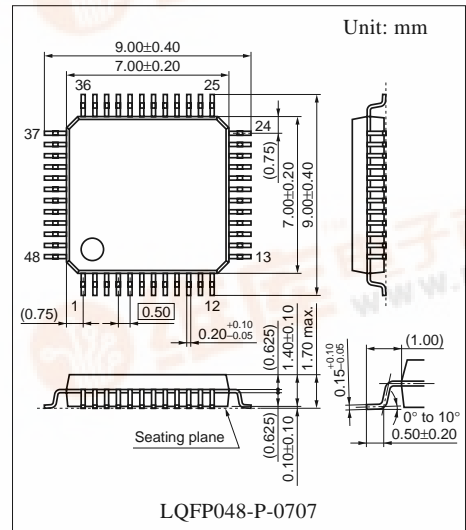

■ Block Diagram

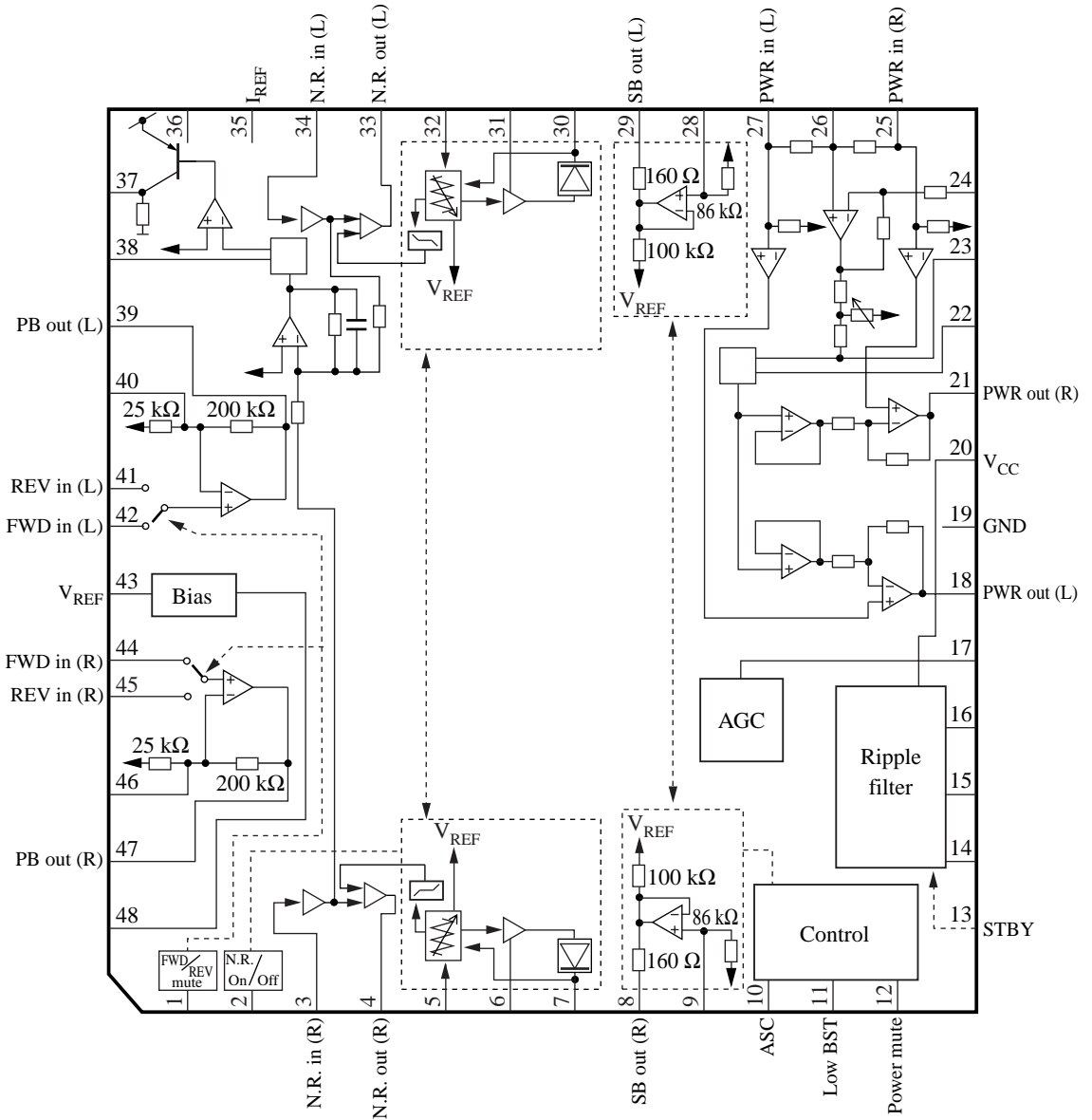

■ Pin Descriptions

Pin No.	Description	Pin No.	Description
1	FWD/REV/pre-mute control	25	Power input (R)
2	Noise reduction on/off control	26	LPF1 capacitor pin
3	N.R. decoder input (R)	27	Power input (L)
4	N.R. decoder output (R)	28	Sub-buffer amp. input (L)
5	Side-chain filter (R)	29	Sub-buffer amp. output (L)
6	Weighting amp. filter (R)	30	Control voltage ripple filter (L)
7	Control voltage ripple filter (R)	31	Weighting amp. filter (L)
8	Sub-buffer amp. output (R)	32	Side-chain filter (L)
9	Sub-buffer amp. input (R)	33	N.R. decoder output (L)
10	Sub-buffer amp. on/off control	34	N.R. decoder input (L)
11	Low boost on/off control	35	Reference current resistance pin
12	Power mute on/off control	36	MS LPF C pin
13	Standby on/off control	37	MS output
14	Ripple filter input	38	MS filter pin
15	Ripple filter base pin	39	Playback amp. output (L)
16	Ripple filter output	40	Playback amp. negative feedback input (L)
17	AGC time constant	41	Playback amp. REV input (L)
18	Power output (L)	42	Playback amp. FWD input (L)
19	GND pin	43	Reference voltage output
20	Positive power supply	44	Playback amp. FWD input (R)
21	Power output (R)	45	Playback amp. REV input (R)
22	Low boost capacitor pin 2	46	Playback amp. negative feedback input (R)
23	LPF2 capacitor pin	47	Playback amp. output (R)
24	Low boost capacitor pin 1	48	Reference voltage input

■ Absolute Maximum Ratings

Parameter	Symbol	Rating	Unit
Supply voltage	V_{CC}	2.1	V
Supply current	I_{CC}	20	mA
Power dissipation *2	P_D	249	mW
Operating ambient temperature *1	T_{opr}	-20 to +70	°C
Storage temperature *1	T_{stg}	-55 to +125	°C

Note) *1: Except for the operating ambient temperature and storage temperature, all ratings are for $T_a = 25^\circ\text{C}$.

*2: $T_a = 75^\circ\text{C}$

■ Recommended Operating Range

Parameter	Symbol	Range	Unit
Supply voltage	V_{CC}	0.98 * to typ. 1.2 to 2.0	V

Note) *: Supply voltage of V_{CC} of 0.95 V to 0.98 V is permissible as long as it does not cause any abnormal operation such as oscillation.

■ Electrical Characteristics at $V_{CC} = 1.2$ V, $f = 1$ kHz, $R_L = 32$, $T_a = 25^\circ\text{C}$

Parameter	Symbol	Conditions	Min	Typ	Max	Unit
Voltage gain	G_V	$V_O = -22.2$ dBV	54	57	60	dB
Circuit current 1	I_{CC1}	$V_{IN} = 0$, $R_g = 2.2$ k Ω , L. BST off, N.R. off	—	3.2	5.9	mA
Circuit current 2	I_{CC2}	$V_{IN} = 0$, $R_g = 2.2$ k Ω , L. BST off, N.R. on	—	4.4	7.1	mA
Circuit current 3	I_{CC3}	$P_{out} = 0.5$ mW \times 2-ch., $R_L = 32$ Ω	—	7.0	11.2	mA
Circuit current 4	I_{CC4}	$P_{out} = 0.5$ mW \times 2-ch., $R_L = 32$ Ω , N.R. on	—	8.4	12.8	mA
Circuit current 5	I_{CC5}	STBY on	—	15	30	μ A

Pre-amp. block

Open-loop voltage gain	$G_{VO(PB)}$	$V_O = -22.2$ dBV	61	73	—	dB
Close-loop voltage gain	$G_{VC(PB)}$	$V_O = -22.2$ dBV	32.5	34	35.5	dB
Max. output voltage	$V_{omax(PB)}$	THD = 1%, 30 kHz, LPF on	120	210	—	mV
Total harmonic distortion	$THD_{(PB)}$	$V_O = -22.2$ dBV, 30 kHz, LPF on, $G_{VC} = 35$ dB (NAB)	—	0.2	0.6	%
Output noise voltage	$V_{NO(PB)}$	$R_g = 2.2$ k Ω , IHF-A	—	-90	-76	dBV
Channel separation	$CS_{(PB)}$	Single ch. input, 1 kHz, BPF on, $R_g = 2.2$ k Ω , $V_O = -22.2$ dBV	37	46	—	dB
FWD/REV crosstalk	$CT_{(PB)}$	Single ch. input, 1 kHz, BPF on, $R_g = 2.2$ k Ω , $V_O = -22.2$ dBV	51	59	—	dB
Ripple rejection factor	$RR_{(PB)}$	$R_g = 2.2$ k Ω , $V_{RR} = -32.2$ dBV, $f_{RR} = 100$ Hz, $I_{RFO} = 15$ mA, BPF: 100 Hz, 1/4 OCT	43	53	—	dB
Mute attenuation amount	$G_{MUTE(PB)}$	Ratio to $V_O = -22.2$ dBV, pre-mute on	—	-85	-70	dB

Heavy low sound + power amp. block

Gain voltage 1	$G_{V1(PW)}$	$V_O = -22.2$ dBV	21	23	25	dB
Gain voltage 2	$G_{V2(PW)}$	L. boost on, $V_O = -22.2$ dBV	21.4	23.4	25.4	dB
Low frequency boost amount	$G_{V3(PW)}$	L. boost on/off, $f = 50$ Hz, $V_{IN} = 65.2$ dBV	15	19	23	dB
Rated output power	P_{out}	THD = 10%, 30 kHz, LPF on	2.5	4.5	—	mW
Total harmonic distortion	$THD_{(PW)}$	$P_{out} = 1$ mW, 30 kHz, LPF on	—	0.35	1.3	%
Channel separation 1	$CS1_{(PW)}$	Single ch. input, 1 kHz, BPF, $R_g = 0$, $V_O = -22.2$ dBV	33	40	—	dB

■ Electrical Characteristics at $V_{CC} = 1.2\text{ V}$, $f = 1\text{ kHz}$, $R_L = 32\ \Omega$, $T_a = 25^\circ\text{C}$ (continued)

Parameter	Symbol	Conditions	Min	Typ	Max	Unit
Heavy low sound + power amp. block (continued)						
Channel separation 2	$CS2_{(PW)}$	Single ch. input, Low boost on, $R_g = 0$, $V_O = -22.2\text{ dBV}$, 1 kHz, BPF	25	31	—	dB
Output noise voltage 1	$V_{NO1(PW)}$	$R_g = 0$, IHF-A	—	-91	-86	dBV
Output noise voltage 2	$V_{NO2(PW)}$	Low boost on, $R_g = 0$, IHF-A	—	-86	-82	dBV
Ripple rejection factor 1	$RR1_{(PW)}$	$R_g = 0$, $V_{RR} = -32.2\text{ dBV}$, $f_{RR} = 100\text{ Hz}$, $I_{RFO} = 15\text{ mA}$, BPF: 100 Hz, 1/4 OCT	60	72	—	dB
Ripple rejection factor 2	$RR2_{(PW)}$	Low boost on, $R_g = 0$, $V_{RR} = -32.2\text{ dBV}$, $f_{RR} = 100\text{ Hz}$, $I_{RFO} = 15\text{ mA}$, BPF: 100 Hz, 1/4 OCT	40	61	—	dB
Input resistance	$R_{IN(PW)}$		7.2	9.5	12	k Ω
Channel balance	$CB_{(PW)}$	$V_O = -22.2\text{ dBV}$	-1.5	0	1.5	dB
Mute output voltage	$V_{MUTE(PW)}$	$V_{IN} = -32.2\text{ dBV}$	—	-96	-90	dBV
AGC level	V_{AGC}	$V_{IN} = -45.2\text{ dBV}$, $f = 100\text{ Hz}$, $R_L = 32\ \Omega$, AGC level to be measured at 32 Ω end.	-17.3	-14.7	-13.1	dBV
Output DC step	$DV_{(PW)}$	PWR mute (pin 12) on/off	-30	0	30	mV
Dolby block						
Reference input level *1	$V_{IN(NR)}$	N.R.: Off, BEF: Off, $f = 1\text{ kHz}$, $V_O = -32.2\text{ dBV}$	-33.9	-32.8	-31.7	dBV
Channel balance	$CB_{(NR)}$	(Calculation) channel ratio of the above V_{IN}	-1	0	1	dB
N.R. decode characteristics 1 *2	$G_{(NRD1)}$	N.R.: On, BEF: Off, $f = 10\text{ kHz}$, $V_{IN} = -29.6\text{ dB}$, Calculation $NRD = V_O + 40\text{ (dB)}$	-2	0	2	dB
N.R. decode characteristics 2 *2	$G_{(NRD2)}$	N.R.: On, BEF: Off, $f = 1\text{ kHz}$, $V_{IN} = -23.9\text{ dB}$, Calculation $NRD = V_O + 30\text{ (dB)}$	-2	0	2	dB
N.R. decode characteristics 3 *2	$G_{(NRD3)}$	N.R.: On, BEF: Off, $f = 1\text{ kHz}$, $V_{IN} = -15.8\text{ dB}$ Calculation $NRD = V_O + 20\text{ (dB)}$	-3.0	0	3.0	dB
N.R. decode characteristics 4 *2	$G_{(NRD4)}$	N.R.: On, BEF: Off, $f = 10\text{ kHz}$, $V_{IN} = -17.4\text{ dB}$ Calculation $NRD = V_O + 20\text{ (dB)}$	-2.5	0	2.5	dB
N.R. decode characteristics 5 *2	$G_{(NRD5)}$	N.R.: On, BEF: Off, $f = 10\text{ kHz}$, $V_{IN} = 0.4\text{ dB}$, Calculation $NRD = V_O\text{ (dB)}$	-2	0	2	dB

Note) *1: Adjust an input level to get an output level of -3.2 dBV at a measuring point (N.R. out) so that you can get 0 dB of reference input level.

*2: V_O in the calculating equation is the output level based on reference of 0 dB = -32.2 dBV (measuring point: N.R. out).

■ Electrical Characteristics at $V_{CC} = 1.2\text{ V}$, $f = 1\text{ kHz}$, $R_L = 32$, $T_a = 25^\circ\text{C}$ (continued)

Parameter	Symbol	Conditions	Min	Typ	Max	Unit
Dolby block (continued)						
Total harmonic distortion 1 *3	THD1 _(NR)	N.R.: Off, BEF: On, $f = 1\text{ kHz}$, $V_{IN} = +10\text{ dB}$, 30 kHz, LPF on	—	0.2	0.5	%
Total harmonic distortion 2 *3	THD2 _(NR)	N.R.: On, BEF: Off, $f = 1\text{ kHz}$, $V_{IN} = +10\text{ dB}$, 30 kHz, LPF on	—	0.3	0.8	%
Total harmonic distortion 3 *3 (Signal handling)	THD3 _(NR)	N.R.: On, BEF: Off, $f = 1\text{ kHz}$, $V_{IN} = +12\text{ dB}$ $V_{CC} = 1.1\text{ V}$, 30 kHz, LPF on	—	0.3	1	%
Signal to noise ratio, N.R. on *4	$V_{NO(NR)}$	N.R.: On, BEF: Off, Input pin $R_g = 15\text{ k}\Omega$, CCIR/ARM filter	70	72	—	dB
Sub-buffer filter characteristic *5	G_{VOP2}	N.R.: Off, BEF: On/off, $f = 6.3\text{ kHz}$, $V_{IN} = 0\text{ dB}$	—	-12	-8	dB
Ripple filter block						
Ripple rejection factor	RR	$V_{CC} = 1.1\text{ V}$, $V_{RR} = -32.2\text{ dBV}$ $f_{RR} = 100\text{ Hz}$, $I_{RFO} = 15\text{ mA}$ BPF: 100 Hz, 1/4 OCT	24	30	—	dB
DC output voltage	V_{RPF}	$V_{CC} = 1.0\text{ V}$, $I_{RFO} = 15\text{ mA}$	0.89	0.94	—	V
Bias block						
DC output voltage	V_{REF}	$V_{CC} = 1.0\text{ V}$	0.68	0.76	0.83	V
AMS block						
Music detection level 1	V_{BS}	Power mute on, at $V_{37} = 0.6\text{ V}[p-0]$	-50.6	-49	-47.4	dBV
Music detection level 2	V_{MS}	Power mute off, at $V_{37} = 0.6\text{ V}[p-0]$	-66.6	-65	-63.4	dBV
Control block						
Standby-off voltage	V_{STOFF}	Low: Power on	—	—	0.4	V
Standby-on voltage	V_{STON}	High/open: Power off	0.75	—	—	V
Standby pin current	I_{STBY}	$V_{13} = 0\text{ V}$	—	16	45	μA
Power mute-on threshold	V_{MTON}	Low: Power mute on	—	—	0.3	V
Power mute-off threshold	V_{MTOFF}	High/open: Power mute off	1.05	—	—	V
Power mute pin current	I_{SW12}	$V_{12} = 0.1\text{ V}$	—	20	40	μA
FWD/REV/pre-mute low threshold	V_{THIL}	Low: REV	—	—	0.1	V
FWD/REV/pre-mute high threshold	V_{THIH}	High: Pre-mute on	1.1	—	—	V
FWD/REV/pre-mute pin current	I_{SW1}	$V_1 = 0.1\text{ V}$	—	9	18	μA
Low-boost on threshold	V_{LBON}	Low: Low boost on	—	—	0.3	V
Low-boost pin current	I_{SW11}	$V_{11} = 0.1\text{ V}$	—	20	40	μA
N.R. on threshold	V_{NROn}	Low: N.R. on	—	—	0.4	V
N.R. off threshold	V_{NROff}	High/open : N.R. off	0.8	—	—	V

Note) *3: Measuring point: SB out

*4: Measuring point: N.R. out

*5: Attenuation amount referred to sub-buffer off (measuring point: SB out).

■ Electrical Characteristics at $V_{CC} = 1.2\text{ V}$, $f = 1\text{ kHz}$, $R_L = 32$, $T_a = 25^\circ\text{C}$ (continued)

Parameter	Symbol	Conditions	Min	Typ	Max	Unit
Control block (continued)						
N.R. pin current	I_{SW2}	$V_2 = 0.1\text{ V}$	—	8	16	μA
Sub-buffer on threshold	V_{SBON}	Low: SB on	—	—	0.4	V
Sub-buffer off threshold	V_{SBOFF}	High/open: SB off	0.8	—	—	V
Sub-buffer pin current	I_{SW10}	$V_{10} = 0.1\text{ V}$	—	20	40	μA

■ Terminal Equivalent Circuits

Pin No.	Equivalent circuit	Description	Waveform/voltage (at $V_{CC} = 1.2\text{ V}$)
1		FWD/REV/pre-mute: FWD/REV/pre-mute control Pre-mute High voltage: $V_{CC-0.1} < V_{1-19}$ FWD Pin open REV Low voltage: $V_{1-19} < 0.1$	—
2		N.R. cont.: N.R. on/off control N.R. off Pin open or high voltage: $0.8\text{ V} < V_{2-19} < V_{CC} + 0.3\text{ V}$ N.R. on Low voltage: $-0.3\text{ V} < V_{2-19} < 0.4\text{ V}$	$R_{IN} = 33\text{ k}\Omega$ 0.8 V
3 34		Pin 3: N.R. in (R) Pin 34: N.R. in (L): N.R. decoder input	 $R_{IN} = 30\text{ k}\Omega$ (typ.) DC 0.78 V

■ Terminal Equivalent Circuits (continued)

Pin No.	Equivalent circuit	Description	Waveform/voltage (at $V_{CC} = 1.2\text{ V}$)
4 33		<p>Pin 4: N.R. out (R) Pin 33: N.R. out (L): N.R. decoder output</p>	<p>$R_O = 300\ \Omega$ (typ.) DC 0.78 V</p>
5 32		<p>Pin 5: SC in (R) Pin 32: SC in (L): Side chain input</p>	<p>R_{IN}: Variable according to input signal DC 0.78 V</p>
6 31		<p>Pin 6: WAMP (R) Pin 31: WAMP (L): Weighting amp. filter pin</p>	<p>DC 0.78 V</p>
7 30		<p>Pin 7: VC LPF (R) Pin 30: VC LPF (L): Control voltage ripple filter pin</p>	<p>0 V (Add external resistor without signal)</p>

■ Terminal Equivalent Circuits (continued)

Pin No.	Equivalent circuit	Description	Waveform/voltage (at $V_{CC} = 1.2\text{ V}$)
8 29		<p>Pin 8: SB out (R) Pin 29: SB out (L): Sub-buffer amp. output When pin 10 is open or of high voltage and output is connected to V_{REF} with $100\text{ k}\Omega$, the buffer amp. does not operate.</p>	<p>At SB on $R_O = 160\ \Omega$ (typ.) At SB off $R_{IN} = 100\text{ k}\Omega$ (typ.) DC 0.78 V</p>
9 28		<p>Pin 9: SB in (R) Pin 28: SB in (L): Sub-buffer amp. input</p>	<p>$R_{IN} = 86\text{ k}\Omega$ (typ.) DC 0.78 V</p>
10		<p>SB CNT: Sub-buffer amp. on/off control SB off Pin open or high voltage: $0.8\text{ V} < V_{10-19} < V_{CC} + 0.3\text{ V}$ SB on Low voltage: $-0.3\text{ V} < V_{10-19} < 0.4\text{ V}$</p>	<p>$R_{IN} = 6\text{ k}\Omega$ DC 0.78 V</p>
11		<p>L-BST CNT: Low boost on/off control L-BST on Pin open L-BST off Low voltage: $-0.3\text{ V} < V_{10-19} < 0.3\text{ V}$</p>	<p>DC 0 V</p>

■ Terminal Equivalent Circuits (continued)

Pin No.	Equivalent circuit	Description	Waveform/voltage (at $V_{CC} = 1.2\text{ V}$)
12		<p>PWR mute CNT: Power mute on/off control PWR-mute off Pin open or high voltage: $V_{CC} - 0.15\text{ V} < V_{12-19} < V_{CC} + 0.3\text{ V}$ PWR-mute on Low voltage: $- 0.3\text{ V} < V_{12-19} < 0.3\text{ V}$</p>	DC 0 V
13		<p>STBY CNT: Standby on/off control STBY off Pin open or high voltage: $0.75\text{ V} < V_{13-19} < V_{CC} + 0.3\text{ V}$ STBY (on state) on Low voltage: $- 0.3\text{ V} < V_{13-19} < 0.4\text{ V}$</p>	DC 0 V
14		<p>RF in: Ripple filter reference voltage input</p>	DC 1.0 V
15		<p>RF base: Ripple filter</p>	DC 0.47 V
16		<p>V_{RPF} : Ripple filter reference voltage output</p>	DC 1.13 V

■ Terminal Equivalent Circuits (continued)

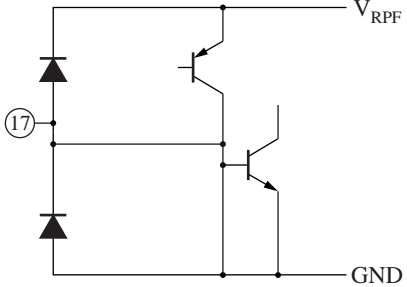
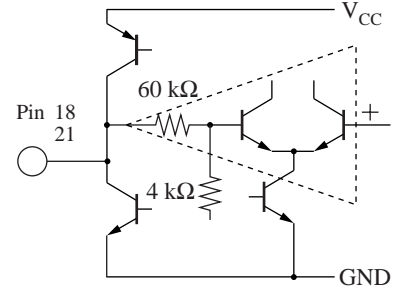
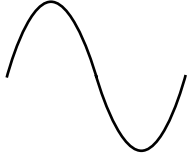
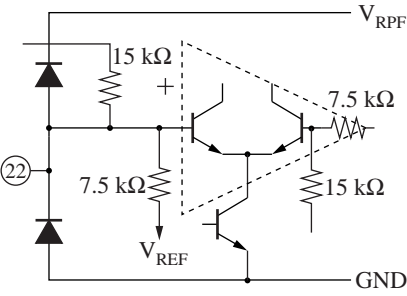
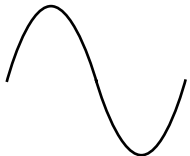
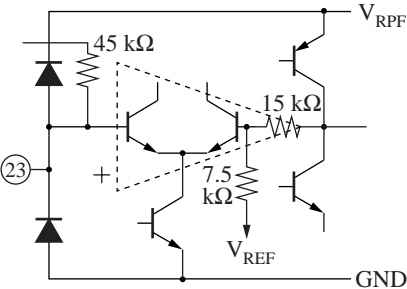
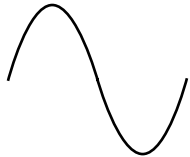
Pin No.	Equivalent circuit	Description	Waveform/voltage (at $V_{CC} = 1.2\text{ V}$)
17		AGCTAU: AGC time constant	—
18 21		Pin 18: PWR out (L) Pin 21: PWR out (R): Power amp. voltage output	 DC 0.6 V
19	—	GND pin	0 V
20	—	V_{CC} power supply pin	1.2 V
22		L-BST C: Low boost capacitor pin	 DC 0.78 V
23		LPF2-C: LPF2 capacitor pin	 DC 0.78 V

■ Terminal Equivalent Circuits (continued)

Pin No.	Equivalent circuit	Description	Waveform/voltage (at $V_{CC} = 1.2\text{ V}$)
24		<p>L-BST C1: Low boost capacitor pin</p>	<p>DC 0.78 V</p>
25 27		<p>Pin 25: PWR in (R) Pin 27: PWR in (L): Power amp. input</p>	<p>DC 0.78 V AC -30 dBm</p>
26		<p>LPF1-C: LPF capacitor pin</p>	<p>DC 0.78 V</p>
35		<p>I_{REF} : Reference current resistor pin</p>	<p>DC 0.1 V</p>

■ Terminal Equivalent Circuits (continued)

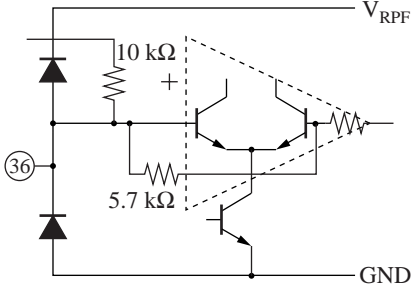
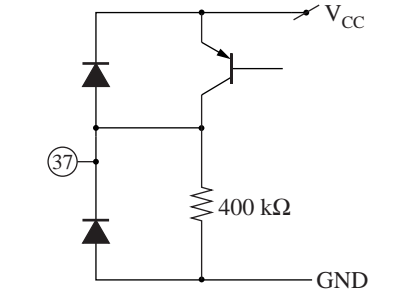
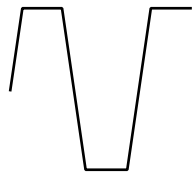
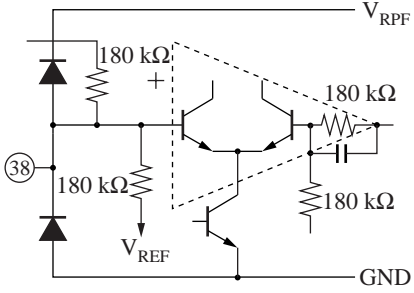
Pin No.	Equivalent circuit	Description	Waveform/voltage (at $V_{CC} = 1.2\text{ V}$)
36		<p>MS LPF-C: Music interval detection LPF capacitor pin</p>	<p>—</p>
37		<p>MS out: Music interval detection output</p>	
38		<p>MS-C: Music interval detection filter capacitor pin</p>	<p>DC 0.78 V</p>

■ Terminal Equivalent Circuits (continued)

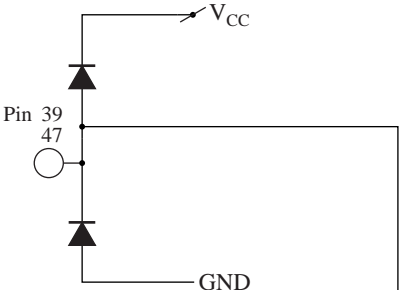
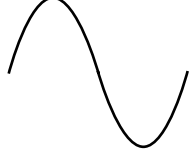
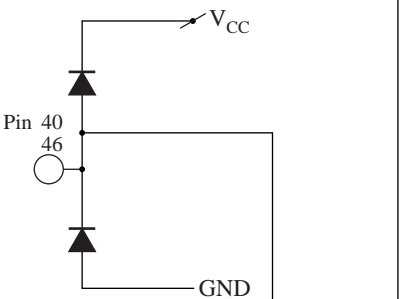
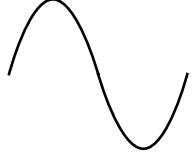
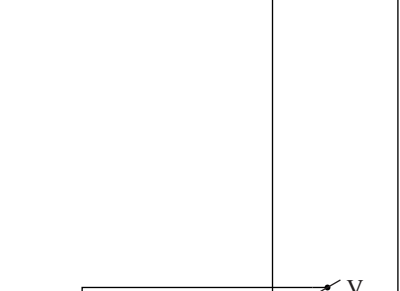
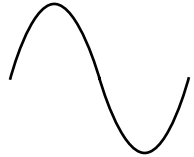
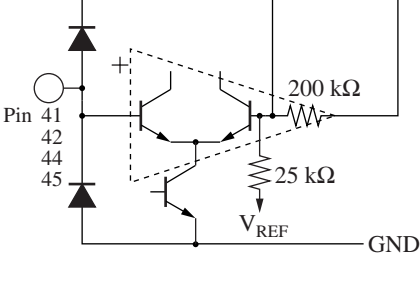
Pin No.	Equivalent circuit	Description	Waveform/voltage (at $V_{CC} = 1.2\text{ V}$)
39 47		<p>Pin 39: PB out (L) Pin 47: PB out (R): Playback amp. output</p>	 <p>DC 0.6 V AC -30 dBm</p>
40 46		<p>Pin 40: PB NF (L) Pin 46: PB NF (R): Playback amp. negative feedback input</p>	 <p>DC 0.78 V 1 kHz -65 dBm</p>
41 45		<p>Pin 41: REV in (L) Pin 45: REV in (R): Playback amp. REV input</p>	 <p>DC 0.78 V AC -65 dBm</p>
42 44		<p>Pin 42: FWD in (L) Pin 44: FWD in (R): Playback amp. FWD input</p>	

■ Terminal Equivalent Circuits (continued)

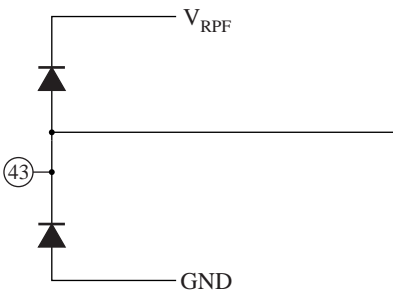
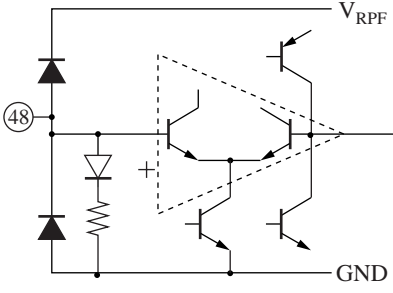
Pin No.	Equivalent circuit	Description	Waveform/voltage (at $V_{CC} = 1.2\text{ V}$)
43		V_{REF} : Reference voltage output	DC 0.78 V
48		V_{REF} in: Reference voltage input	DC 0.78 V

■ Application Circuit Example

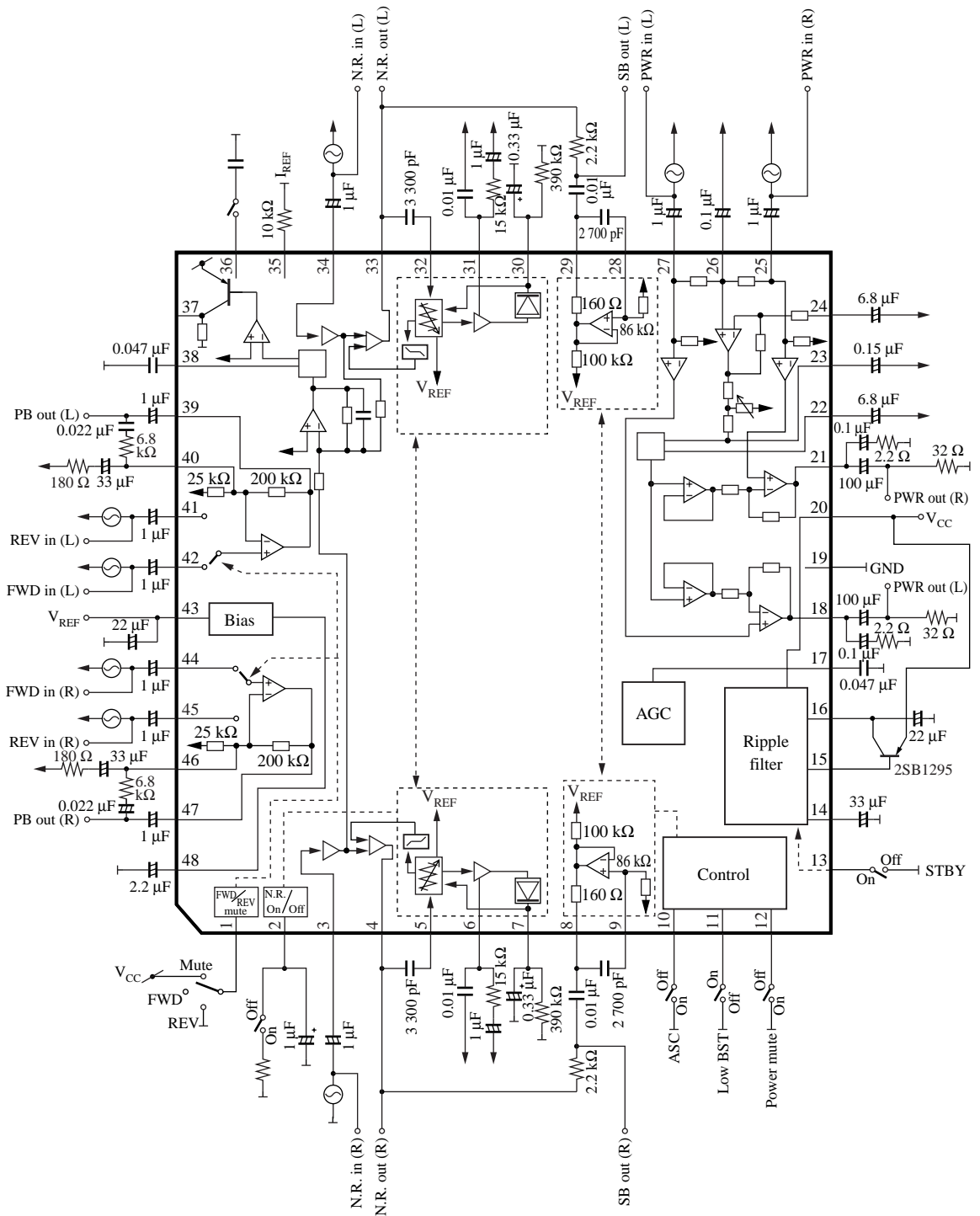

Note) Dolby and double D logos are the trademarks of Dolby Laboratories Licensing Corporation.
 The use of this product requires the prior approval of Dolby Laboratories Licensing Corporation.