

AN8021NS

External excitation flyback AC-DC switching power supply control IC

Overview

The AN8021S is a switching power supply control IC that controls the power supply from the primary side. It is optimal for relatively small switching power supplies. All rarely used functions have been removed from the AN8021S and as a result it is an extremely easy-to-use compact device. Furthermore, internal settings are implemented as many as we can, cost cut is possible with reduced external parts.

Features

- Supports operation at switching frequencies up to 700 kHz and achieves a 35 ns output rise time and a 25 ns output fall time.
- Extremely low pre-startup current consumption of 70 μ A (typical) allows a significantly smaller startup resistor to be used.
- Totem pole circuit structure adopted in the output block.
- Output current absolute maximum rating of ± 1.0 A (peak) for direct driving of power MOSFET.
- Pulse-by-pulse overcurrent protection circuit
- Low voltage malfunction prevention circuit
On/off: 14.2 V/9.2 V
- Timer latch and overvoltage protection functions
- Package: SONF-8D

Applications

- Switching power supplies

Block Diagram

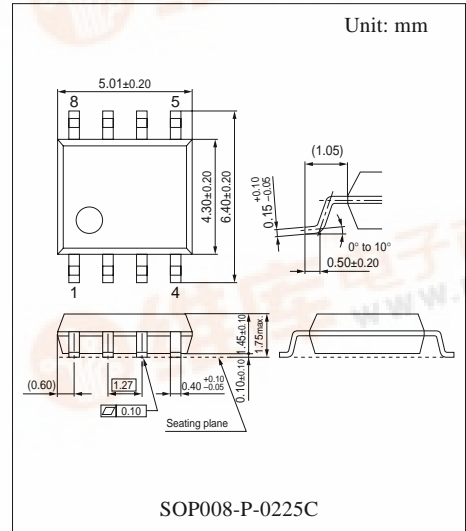
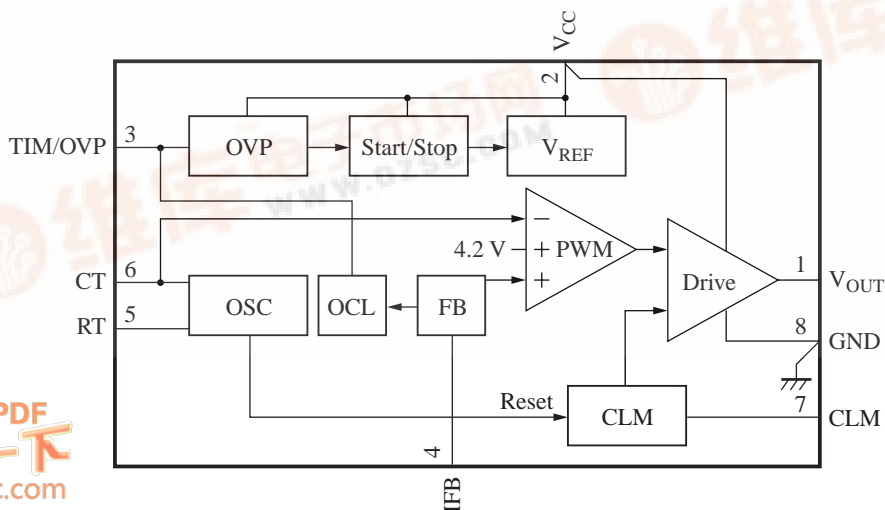

■ Pin Descriptions

Pin No.	Symbol	Description
1	V_{OUT}	Direct power MOSFET drive output
2	V_{CC}	Power supply. This pin monitored, and has threshold voltages for startup, stop, OVP reset, and other functions.
3	TIM/OVP	OVP (overvoltage protection) and timer latch functions. OVP: Accepts a power supply overvoltage detection signal. When a high-level signal is input, internal circuits are turned off and this state is latched. To reset this OVP latched state, the V_{CC} voltage should be lowered to below the release voltage. Timer latch: The IC detects output voltage drops due to overcurrent states in the power supply output by monitoring the magnitude of the current input to the IFB pin. In particular, when the current I_{IFB} has fallen below a certain level, a charge current flows into the capacitor connected to this pin externally. When that capacitor is charged to the OVP threshold voltage, OVP operates and the IC keeps a stopped state.
4	IFB	Input for the current feedback signal provided from a photocoupler of the power supply output.
5	RT	Connection for the resistor that determines the charge and discharge currents of the triangular wave. In this device, the charge and discharge currents are the same.
6	CT	Connection for the capacitor used to generate the triangular wave.
7	CLM	Pulse-by-pulse overcurrent protection input. Normally, an external filter is required.
8	GND	Ground

■ Absolute Maximum Ratings

Parameter	Symbol	Rating	Unit
Supply voltage	V_{CC}	35	V
OVP pin allowable application voltage	V_{OVP}	V_{CC}	V
CLM pin allowable application voltage	V_{CLM}	-0.3 to +7.0	V
Supply current	I_{CC}	—	mA
Steady-state output current	I_O	+150	mA
Peak output current	I_{OP}	±1 000	mA
IFB pin allowable application current	IFB	-5	mA
Power dissipation ^{*2}	P_D	122	mW
Operating temperature ^{*1}	T_{opr}	-30 to +85	°C
Storage temperature ^{*1}	T_{stg}	-55 to +150	°C

Notes) 1. ^{*1}: Items other than the storage temperature and operating temperature are all stipulated for an ambient temperature $T_a = 25^\circ\text{C}$.

^{*2}: Applies when $T_a = 85^\circ\text{C}$ for the independent IC without a heat sink.

2. Currents or voltages may not be applied to any pins not stipulated above. For circuit currents, a positive (+) value indicates current flowing into the IC, and a negative (-) value indicates current flowing out of the IC.

■ Recommended Operating Range

Parameter	Symbol	Range	Unit
Supply voltage	V_{CC}	The stop voltage to 34	V

■ Electrical Characteristics at $T_a = 25^\circ\text{C}$

Parameter	Symbol	Conditions	Min	Typ	Max	Unit
Start voltage	STRT V_{CC}		13.0	14.2	15.4	V
Stop voltage	STOP V_{CC}		8.5	9.2	9.9	V
Standby mode bias current	STB I_{CC}	$V_{CC} = 12\text{ V}$	50	70	105	μA
Operating bias current	OPR I_{CC}	$V_{CC} = 34\text{ V}$	5.9	7.8	9.6	mA
OVP operating bias current 1	OVP1 I_{CC}	$V_{CC} = 20\text{ V}$	2.4	3.0	3.6	mA
OVP operating bias current 2	OVP2 I_{CC}	$V_{CC} = 10\text{ V}$	0.44	0.55	0.66	mA
OVP operating threshold voltage	CVP V_{TH}	$V_{CC} = 18\text{ V}$	5.4	6.0	6.6	V
OVP release supply voltage	OVPC V_{CC}		7.6	8.4	9.2	V
Timer latch charge current	TIM I_{CH}	$V_{CC} = 18\text{ V}$, $R_T = 19\text{ k}\Omega$	-15	-25	-35	μA
Timer latch start feedback current	TIM I_{FB}	$V_{CC} = 18\text{ V}$	-0.37	-0.5	-0.63	mA
Overcurrent protection threshold voltage	CLM V_{TH}	$V_{CC} = 18\text{ V}$	-180	-200	-220	mV
Pre-startup low-level output voltage	STB V_{OL}	$V_{CC} = 12\text{ V}$, $I_O = 10\text{ mA}$	—	0.8	1.8	V
Low-level output voltage	V_{OL}	$V_{CC} = 18\text{ V}$, $I_O = 100\text{ mA}$	—	1.3	1.8	V
High-level output voltage	V_{OH}	$V_{CC} = 18\text{ V}$, $I_O = -100\text{ mA}$	15.0	16.5	—	V
Oscillator frequency *	f_{OSC1}	$V_{CC} = 18\text{ V}$	170	180	190	kHz
Maximum duty factor	D_{max}	$V_{CC} = 18\text{ V}$	62	66	70	%
Feedback current at 0% duty	D_{min} , I_{FB}	$V_{CC} = 18\text{ V}$	-1.1	-1.5	-1.9	mA
Feedback current at maximum duty	D_{max} , I_{FB}	$V_{CC} = 18\text{ V}$	-0.37	-0.5	-0.63	mA

Note) *: Provisional rating

• Design reference data

Note) The characteristics listed below are theoretical values based on the IC design and are not guaranteed.

Parameter	Symbol	Conditions	Min	Typ	Max	Unit
Oscillator frequency 2	f_{OSC2}	$T_a = -30^\circ\text{C}$ to $+85^\circ\text{C}$, $V_{CC} = 18\text{ V}$	160	—	240	kHz
Overcurrent protection delay time	CLM t_{DLY}	$V_{CC} = 18\text{ V}$, no load.	—	200	—	ns
Output voltage rise time	t_r	$V_{CC} = 18\text{ V}$, no load.	—	50	—	ns
Output voltage fall time	t_f	$V_{CC} = 18\text{ V}$, no load.	—	25	—	ns

■ Application Circuit Example

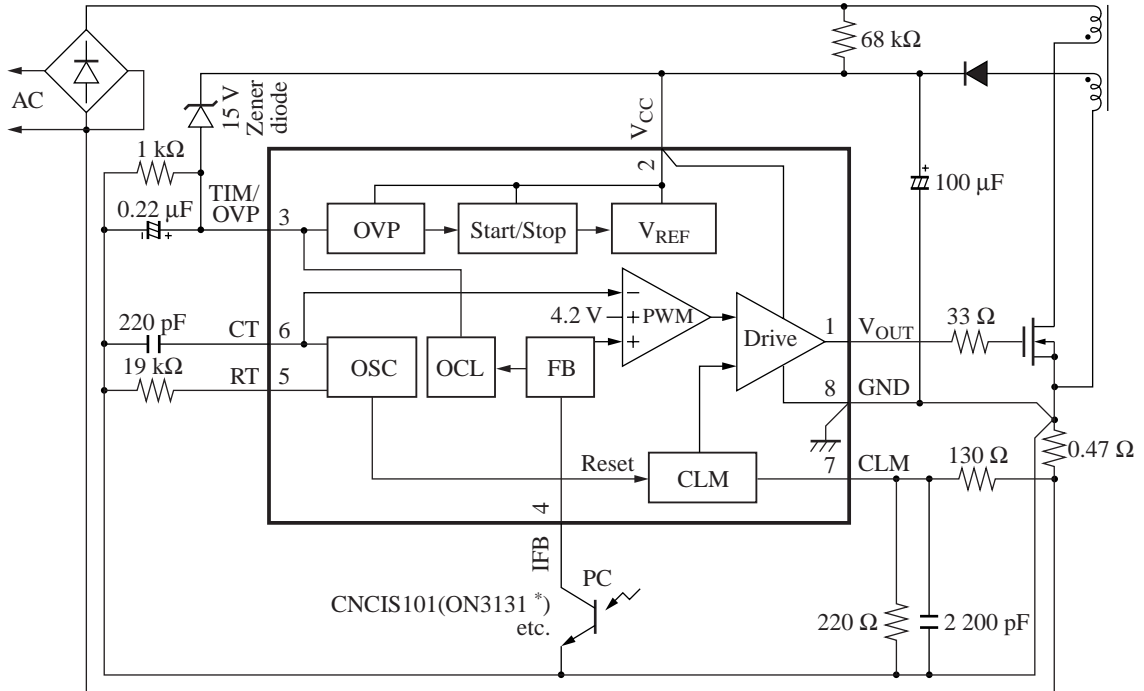

Note) 1. The external circuits and circuit constants are provided as an example of a possible design. No guarantees are made with respect to these items for use in mass produced end products.

2. *: Former part number

■ Usage Notes

1. Direct connection with the power supply pin (shorting to V_{CC})
In this device, pins other than pin 3 cannot be connected directly to the power supply pin (pin 2).
Connection of any other pins to V_{CC} will result in permanent damage to the device.
2. Direct connection with the ground pin (shorting to ground)
In this device, pin 1 cannot be connected directly to the ground pin (pin 8).
Connection of this pin to ground will result in permanent damage to the device.