

Others

**Panasonic**

# AN8072N

## Multi Output Power Supply Regulator

### Overview

The AN8072N is a multi-output IC designed for power supply regulator incorporating 5-ch positive output power supply which is 2-ch 8V output, 2-ch 10V output and 1-ch 10V output. It is most suitable for equipments which need multi supply voltage supply.

### Features

- Operating supply voltage range :  $V_{CC(opr.)} = 10.5V \sim 16V$  (Battery Voltage)
- Low power consumption :  $I_{CC} = 1.6mA$  typ.
- Overvoltage, output short protection built-in
- 5-ch constant voltage output ON/OFF by battery input, ACC input and control input

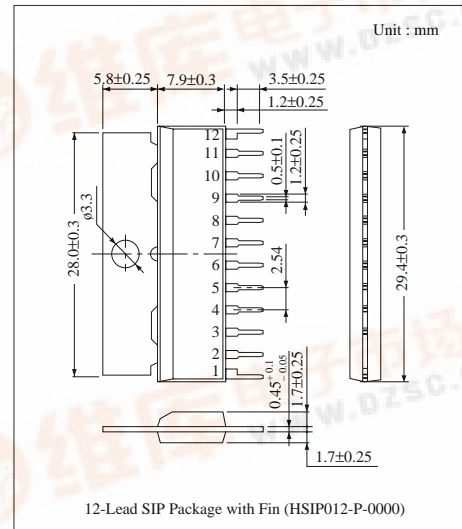

### Main Characteristics

	Output Voltage	Max. Load Current	Input Stability (max.)	Load Stability (max.)	Protection Circuit		Output ON/OFF Function
					Output Short	Overvoltage	
Output 1	8V	200mA	200mV	200mV	Built-in	Built-in	Built-in
Output 2	8V	100mA	150mV	150mV	Built-in	Built-in	Built-in
Output 3	10V	12mA	200mV	200mV	—	—	—
Output 4	5V	60mA	100mV	100mV	Built-in	Built-in	—
Output 5	5V	60mA	100mV	50mV	Built-in	Built-in	—

### Block Diagram

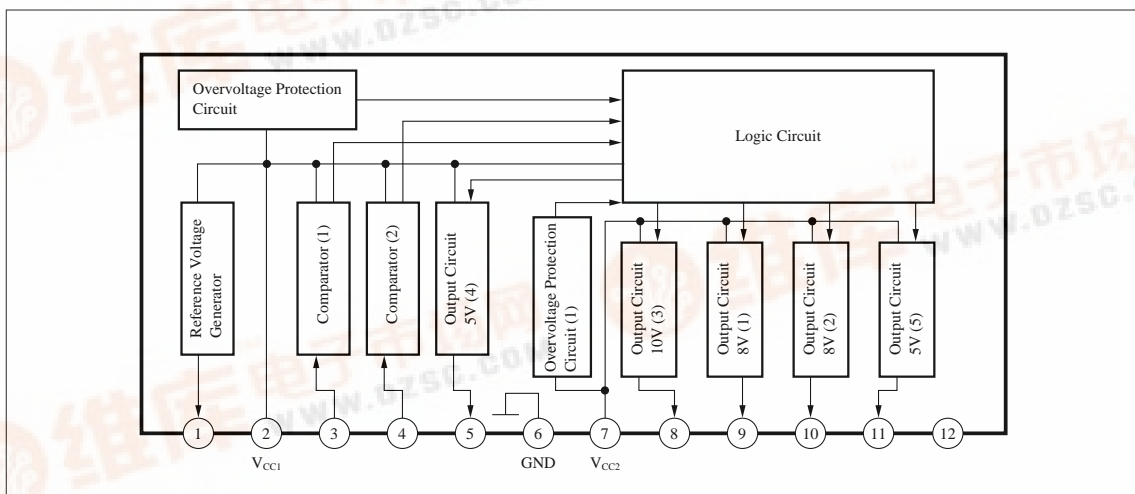

**Panasonic**



### ■ Absolute Maximum Ratings (Ta = 25°C)

Parameter	Symbol	Rating	Unit
Supply Voltage	V <sub>CC</sub>	20	V
Supply Current	I <sub>CC</sub>	340 *	mA
Power Dissipation (Ta = 75°C)	P <sub>D</sub>	1200	mW
Operating Ambient Temperature	T <sub>opr</sub>	- 30 ~ + 75	°C
Storage Temperature	T <sub>stg</sub>	- 55 ~ +150	°C

\* Incorporates a load current 330mA.

### ■ Recommended Operating Range (Ta = 25°C)

Parameter	Symbol	Range
Operating Supply Voltage Range	V <sub>CC1</sub>	10.5V ~ 16V

### ■ Electrical Characteristics (Ta = 25°C) ( Each output is obtained by setting control pin for H/L according to timing chart in P.701. )

Parameter	Symbol	Condition	min.	typ.	max.	Unit
<b>Output 1</b>						
Output Voltage (FM)	V <sub>9-6</sub>	V <sub>2</sub> = 13.2V, I <sub>9</sub> = 120mA	7.6	8	8.32	V
Input Stability	ΔV <sub>9-6</sub>	V <sub>2</sub> = 10.5V~16V, I <sub>9</sub> = 120mA	—	100	200	mV
Load Stability	ΔV <sub>9-6</sub>	V <sub>2</sub> = 13.2V, I <sub>9</sub> = 10mA ~ 200mA	—	80	200	mV
Min. I/O Voltage Difference	V <sub>2-9</sub>	I <sub>9</sub> = 200mA	—	2.1	—	V
<b>Output 2</b>						
Output Voltage (AM)	V <sub>10-6</sub>	V <sub>2</sub> = 13.2V, I <sub>10</sub> = 50mA	7.6	8	8.32	V
Input Stability	ΔV <sub>10-6</sub>	V <sub>2</sub> = 10.5V~16V, I <sub>10</sub> = 50mA	—	60	150	mV
Load Stability	ΔV <sub>10-6</sub>	V <sub>2</sub> = 13.2V, I <sub>10</sub> = 5mA~100mA	—	65	150	mV
Min. I/O Voltage Difference	V <sub>2-10</sub>	I <sub>10</sub> = 100mA	—	1.9	—	V
<b>Output 3</b>						
Output Voltage (V <sub>VAR</sub> )	V <sub>8-6</sub>	V <sub>2</sub> = 13.2V, I <sub>8</sub> = 10mA	9.5	9.9	10.3	V
Input Stability	ΔV <sub>8-6</sub>	V <sub>2</sub> = 10.5V~16V, I <sub>8</sub> = 10mA	—	60	200	mV
Load Stability	ΔV <sub>8-6</sub>	V <sub>2</sub> = 13.2V, I <sub>8</sub> = 1mA~12mA	—	75	200	mV
Min. I/O Voltage Difference	V <sub>7-8</sub>	I <sub>8</sub> = 10mA	—	0.1	—	V
<b>Output 4</b>						
Output Voltage (V <sub>DD</sub> )	V <sub>5-6</sub>	V <sub>2</sub> = 13.2V, I <sub>5</sub> = 30mA	4.7	5	5.2	V
Input Stability	ΔV <sub>5-6</sub>	V <sub>2</sub> = 10.5V~16V, I <sub>5</sub> = 30mA	—	25	100	mV
Load Stability	ΔV <sub>5-6</sub>	V <sub>2</sub> = 13.2V, I <sub>5</sub> = 1mA ~ 60mA	—	40	100	mV
Min. I/O Voltage Difference	V <sub>2-5</sub>	I <sub>5</sub> = 60mA	—	1.8	—	V
<b>Output 5</b>						
Output Voltage (CE)	V <sub>11-6</sub>	V <sub>2</sub> = 13.2V, I <sub>11</sub> = 30mA	4.7	5	5.2	V
Input Stability	ΔV <sub>11-6</sub>	V <sub>2</sub> = 10.5V~16V, I <sub>11</sub> = 30mA	—	40	100	mV
Load Stability	ΔV <sub>11-6</sub>	V <sub>2</sub> = 13.2V, I <sub>11</sub> = 1mA ~ 60mA	—	5	50	mV

■ Application Circuit

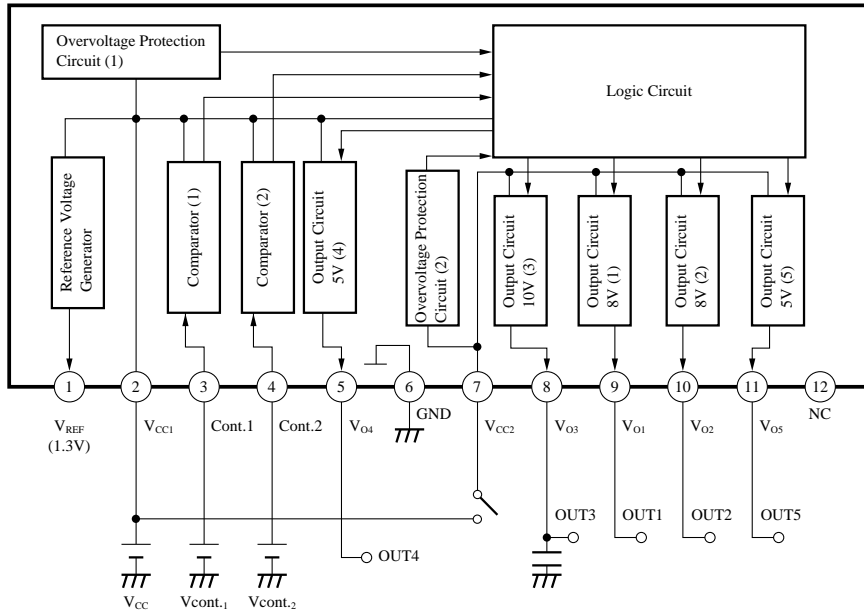

■ Pin Descriptions

Pin No.	Pin Name	Typ. Waveform	Pin Description	Equivalent Circuit
1	Reference Voltage Output Pin	DC 1.3V	IC internal reference voltage for making 5 output. For monitor	—————
2	Supply Pin (1)	DC 13.2V	V <sub>CC</sub> (1)	—————
3	Control Input Pin		For FM AM output switching	
4	Control Input Pin		For FM AM output switching	
5	V <sub>DD</sub> Output Pin	DC 5V	5V output	
6	GND	DC 0V	GND	—————
7	Supply Pin (2)	DC 13.2V	V <sub>CC</sub> (2)	—————
8	V <sub>VAR</sub> Output Pin	DC 10V	10V output	
9	FM Output Pin	DC 8V	8V output	
10	AM Output Pin	DC 8V	8V output	
11	CE Output Pin	DC 5V	5V output	
12	NC	—	NC	—————

■ Supplementary Explanation  
• I/O Timing Chart

