

# AN8261

## Brushless Motor Driver

### Overview

The AN8261 is a 3-phase full-wave brushless motor drive IC and optimum for driving the air conditioner fan motors, etc.

### Features

- Operating supply voltage range :  $V_{CC}=4.5$  to  $7V$
- 3-phase full-wave drive, external power transistor
- Built-in low-voltage protective circuit
- Built-in thermal protective comparator circuit
- Built-in Hall amplifiers with hysteresis

### Applications

Driving the brushless motors such as air conditioner fan motors, etc.

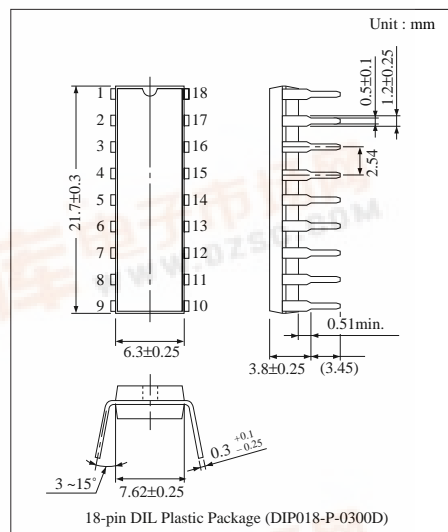

### Block Diagram

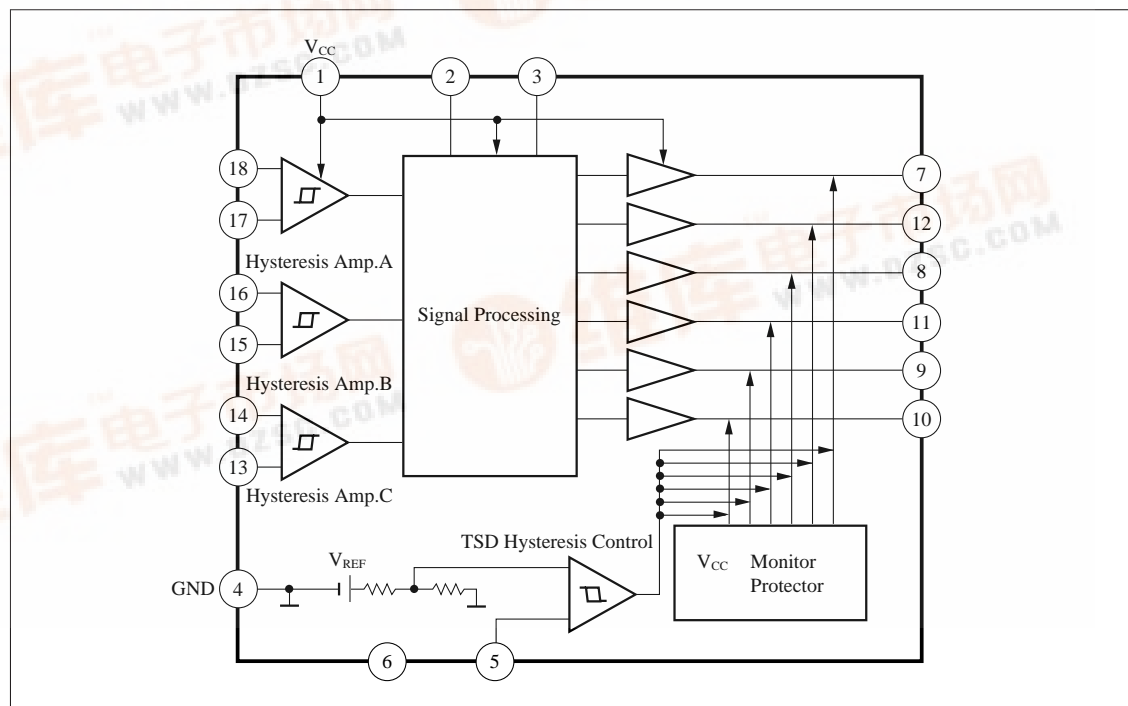

## ■ Absolute Maximum Ratings (Ta=25°C)

Parameter	Symbol	Rating	Unit
Supply voltage	V <sub>CC</sub>	7.5	V
Supply current	I <sub>CC</sub>	80	mA
Output drive current	I <sub>7</sub> , I <sub>8</sub> , I <sub>9</sub> I <sub>10</sub> , I <sub>11</sub> , I <sub>12</sub>	-7 to +25	mA
Power dissipation	P <sub>D</sub>	800	mW
Operating ambient temperature	T <sub>opr</sub>	-20 to +80	°C
Storage temperature	T <sub>stg</sub>	-55 to +150	°C

## ■ Recommended Operating Range (Ta=25°C)

Parameter	Symbol	Range
Operating supply voltage range	V <sub>CC</sub>	4.5V to 7V

## ■ Electrical Characteristics (Ta=25°C)

Parameter	Symbol	Condition	min	typ	max	Unit
Supply current 1	I <sub>CC1</sub>	V <sub>CC</sub> =5V	—	40	56	mA
Supply current 2	I <sub>CC2</sub>	V <sub>CC</sub> =3.5V	—	47	62	mA
Sensor amp. input voltage L to H	V <sub>SLH</sub>	V <sub>CC</sub> =5V	1	10	20	mV
Sensor amp. input voltage H to L	V <sub>SHL</sub>	V <sub>CC</sub> =5V	-20	-10	-1	mV
FG output voltage low level	V <sub>OL</sub>	V <sub>CC</sub> =5V, I <sub>PO</sub> =5mA	—	—	0.4	V
Power drive output voltage high level	V <sub>POH</sub>	V <sub>CC</sub> =5V, I <sub>PO</sub> =-3mA	3.6	—	—	V
Power drive output current high level	I <sub>POH</sub>	V <sub>CC</sub> =5V, V <sub>PO</sub> =2V	-8	-6	-4	mA
Power drive output voltage low level 1	V <sub>POL1</sub>	V <sub>CC</sub> =5V, I <sub>PO</sub> =10mA	—	—	0.4	V
Power drive output voltage low level 2	V <sub>POL2</sub>	V <sub>CC</sub> =5V, I <sub>PO</sub> =20mA	—	—	0.6	V
Power drive output voltage low level 3	V <sub>POL3</sub>	V <sub>CC</sub> =5V, I <sub>PO</sub> =15mA	—	—	0.6	V
Sensor amp. input voltage hysteresis width	V <sub>SW</sub>	V <sub>CC</sub> =5V	12	20	28	mV
FG output pull-up resistance value	R <sub>O</sub>	I <sub>W</sub> =30μA	8	10	12	kΩ
Protect reset voltage	V <sub>R</sub>		3.5	4	4.5	V
Temperature protect operating voltage	V <sub>T</sub>	V <sub>CC</sub> =5V	1	1.15	1.3	V
Temperature protect resetting voltage	V <sub>TR</sub>	V <sub>CC</sub> =5V	0.5	0.63	0.8	V
TSD bias current	I <sub>TSD</sub>	V <sub>CC</sub> =5V, V <sub>TSD</sub> =0.5V	—	—	10	μA
Reference voltage	V <sub>ref</sub>	V <sub>CC</sub> =5V	2	2.3	2.6	V
Reference voltage regulation	V <sub>refREGV</sub>	V <sub>CC</sub> =4V→7V	—	—	0.15	V
Reference voltage load regulation	V <sub>refREGV</sub>	V <sub>CC</sub> =5V, I <sub>O</sub> =0mA→10mA	—	—	0.1	V
V <sub>CC</sub> protect hysteresis width	V <sub>CCW</sub>		100	210	450	mV
Temperature protect operating voltage V <sub>ref</sub> ratio	V <sub>T</sub> /V <sub>ref</sub>	V <sub>CC</sub> =5V	48.5	50	51.5	%
Temperature protect operating voltage V <sub>R</sub> ratio	V <sub>R</sub> /V <sub>ref</sub>	V <sub>CC</sub> =5V	25.3	27.4	29.5	%

## ■ Application Circuit

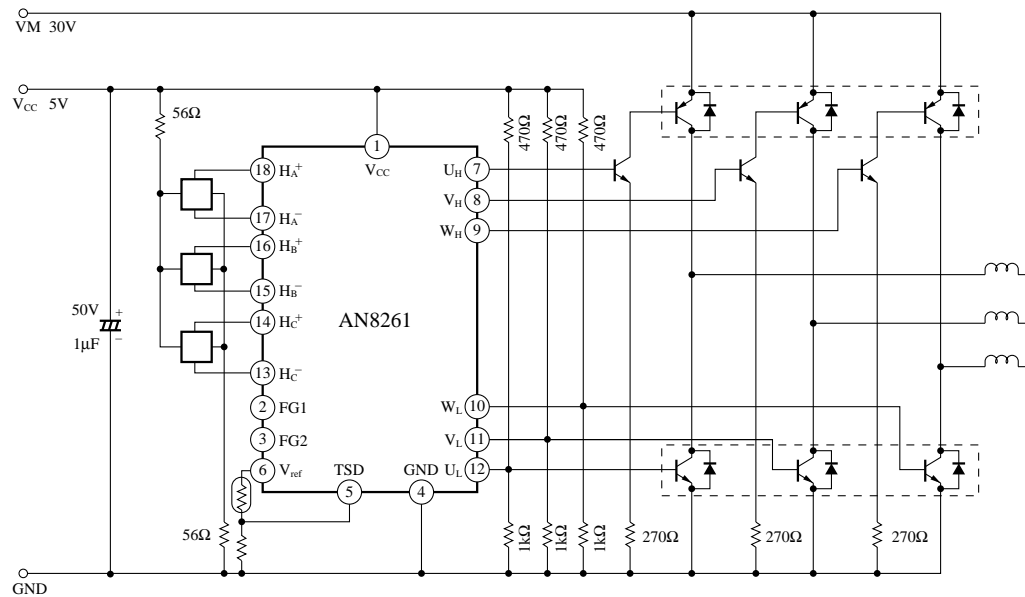

## ■ Pin Descriptions

Pin No.	Pin name	Description	I/O	DC/waveform	Equivalent circuit
1	V <sub>CC</sub>	Supply voltage input pin	I	5V	—
2	FG1	FG signal output pin	O		
3	FG2	FG signal output pin	O		
4	GND	GND pin	I	0V	—
5	TSD	Temperature protect input signal pin	I	—	
6	V <sub>REF</sub>	Reference voltage output pin (TSD reference voltage)	O	2.3V	

## ■ Pin Descriptions (cont.)

Pin No.	Pin name	Description	I/O	DC/waveform	Equivalent circuit
7	UH	Power driver output pin	O	—	
8	VH				
9	WH				
10	WL				
11	VL				
12	UL				
13	HC <sup>-</sup>	Hall element input pin	I	—	
14	HC <sup>+</sup>				
15	HB <sup>-</sup>				
16	HB <sup>+</sup>				
17	HA <sup>-</sup>				
18	HA <sup>+</sup>				

## ■ Logic Diagram

Symbol		No.	1	2	3	4	5	6
Input	HA <sup>+</sup>	18	H	H	L	L	L	H
	HA <sup>-</sup>	17	L	L	H	H	H	L
	HB <sup>+</sup>	16	L	H	H	H	L	L
	HB <sup>-</sup>	15	H	L	L	L	H	H
	HC <sup>+</sup>	14	L	L	L	H	H	H
	HC <sup>-</sup>	13	H	H	H	L	L	L
Output	FG <sub>1</sub>	2	L	L	H	H	H	L
	FG <sub>2</sub>	3	L	H	L	H	L	H
	UH	7	L	L	H	H	L	L
	VH	8	L	L	L	L	H	H
	WH	9	H	H	L	L	L	L
	UL	12	H	L	L	L	L	H
	VL	11	L	H	H	L	L	L
	WL	10	L	L	L	H	H	L