

# AN8488SB

## 3-phase full-wave motor driver and DC motor BTL driver IC

### Overview

The AN8488SB is a motor driver IC incorporating a 3-phase full-wave motor driver and DC motor BTL driver IC with a reverse rotation brake/short brake changeover function. It is encapsulated into a high allowable power dissipation package (with copper block).

### Features

- 3-phase full-wave and snubberless
- FG output
- Current limit
- Reverse rotation prevention
- Thermal protection circuit built-in

### Applications

- Various types of optical disk drive

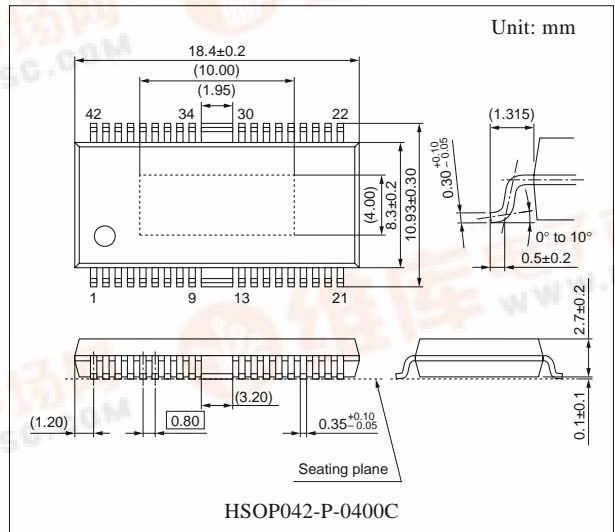

### Block Diagram

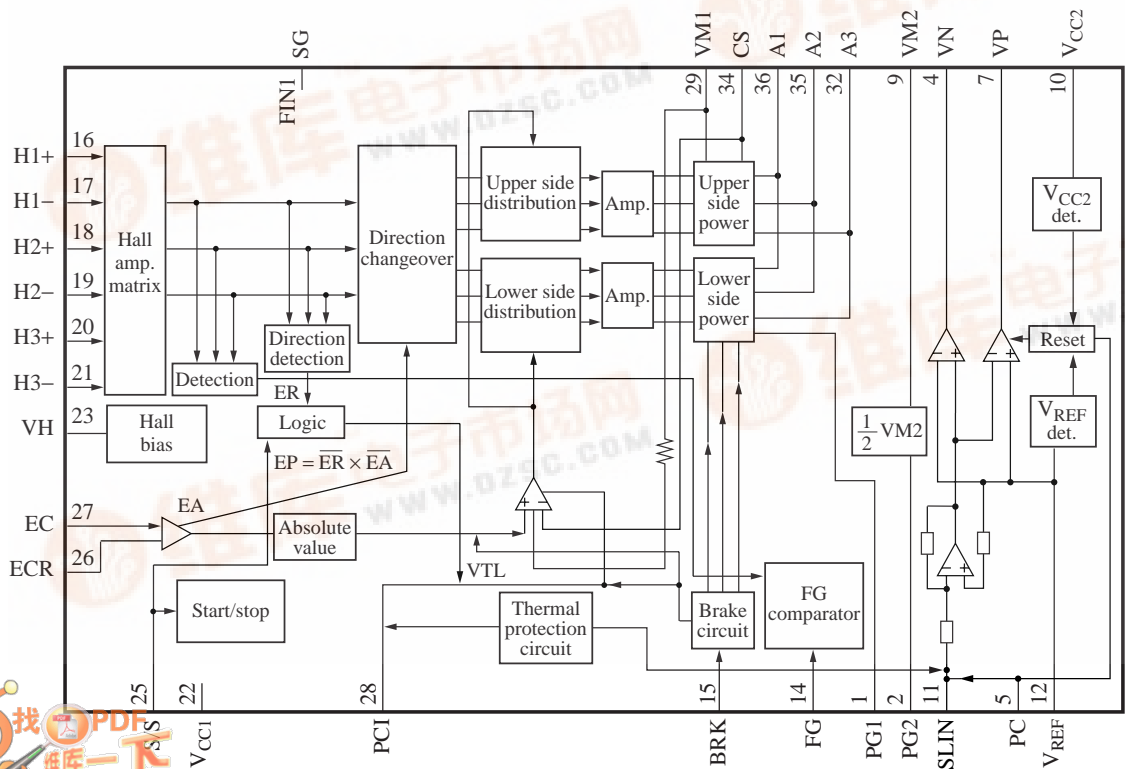

### ■ Pin Descriptions

Pin No.	Symbol	Description	Pin No.	Symbol	Description
1	PG1	SPD block power GND pin	19	H2–	Hall element-2 negative input pin
2	PG2	Driver block power GND pin	20	H3+	Hall element-3 positive input pin
3	N.C.	N.C.	21	H3–	Hall element-3 negative input pin
4	VN	Driver block inverted output pin	22	V <sub>CC1</sub>	SPD block supply voltage pin
5	PC	Driver block power cut pin	23	VH	Hall bias pin
6	N.C.	N.C.	24	N.C.	N.C.
7	VP	Driver block forward output pin	25	SS	Start/stop changeover pin
8	N.C.	N.C.	26	ECR	Torque command reference input pin
9	VM2	Driver block motor power supply pin	27	EC	Torque command input pin
10	V <sub>CC2</sub>	Driver block supply voltage pin	28	PCI	Current feedback phase compensation pin
11	SLIN	Driver block input pin	29	VM1	SPD block motor supply voltage pin
12	V <sub>REF</sub>	Driver block reference input pin	30	N.C.	N.C.
13	N.C.	N.C.	31	N.C.	N.C.
14	FG	FG signal output pin	32	A3	A3 phase output pin
15	BRK	Brake mode setting pin	33	N.C.	N.C.
16	H1+	Hall element-1 positive input pin	34	CS	Current det. pin
17	H1–	Hall element-1 negative input pin	35	A2	A2 phase output pin
18	H2+	Hall element-2 positive input pin	36	A1	A1 phase output pin
FIN1	SG	Signal GND pin	FIN2		

### ■ Absolute Maximum Ratings

Parameter	Symbol	Rating	Unit
Supply voltage	V <sub>CC1</sub>	7.0	V
	V <sub>CC2</sub>	14.0	
	V <sub>M1</sub> , V <sub>M2</sub>		
Output voltage 1 *4	V <sub>O1(n)</sub>	– 0.3 to V <sub>M1</sub> + 0.4	V
Output voltage 2 *5	V <sub>O2(n)</sub>	– 0.3 to V <sub>M2</sub> + 0.4	V
Control signal input voltage *4	V <sub>(n)</sub>	0 to V <sub>CC1</sub>	V
Supply current	I <sub>CC1</sub>	30	mA
Output current *3	I <sub>O(n)</sub>	±1 200	mA
Hall bias current	I <sub>HB</sub>	50	mA
Power dissipation *2	P <sub>D</sub>	786	mW
Operating ambient temperature *1	T <sub>opr</sub>	–20 to +75	°C
Storage temperature *1	T <sub>stg</sub>	–55 to +150	°C

Note) Do not apply external currents or voltages to any pins not specifically mentioned.

For circuit currents, '+' denotes current flowing into the IC, and '-' denotes current flowing out of the IC.

\*1: Except for the operating ambient temperature and storage temperature, all ratings are for T<sub>a</sub> = 25°C.

\*2: The power dissipation shown is the value of independent IC without a heat sink at T<sub>a</sub> = 75°C. Refer to the P<sub>D</sub> — T<sub>a</sub> curves of the "■ Application Notes" for details.

### ■ Absolute Maximum Ratings (continued)

Note) \*3: n = 4, 7, 32, 35, 36

\*4: n = 32, 35, 36

\*5: n = 4, 7

\*6: n = 5, 11, 12, 15, 25, 26, 27

### ■ Recommended Operating Range

Parameter	Symbol	Range	Unit
Supply voltage	$V_{CC1}$	4.25 to 5.5	V
	$V_{CC2}$	4.5 to 13.5	
	$V_{M1}, V_{M2}$		

### ■ Electrical Characteristics at $T_a = 25^\circ\text{C}$

Parameter	Symbol	Conditions	Min	Typ	Max	Unit
<b>Overall</b>						
Circuit current 1	$I_{CC1}$	$V_{CC1} = 5\text{ V}$ , SS: at low	—	0	0.1	mA
Circuit current 2	$I_{CC2}$	$V_{CC2} = 12\text{ V}$ , SS: at low	—	60	200	$\mu\text{A}$
<b>Start/stop</b>						
Start voltage	$V_{START}$	Voltage with which a circuit operates at $V_{CC1} = 5\text{ V}$ and $L \rightarrow H$	2.7	—	—	V
Stop voltage	$V_{STOP}$	Voltage with which a circuit becomes off at $V_{CC1} = 5\text{ V}$ and $H \rightarrow L$	—	—	0.7	V
Medium voltage	$V_{MED}$	Voltage with which $V_{PC1}$ becomes low at $V_{CC1} = 5\text{ V}$ and $EC = 0\text{ V}$	1.425	1.65	1.89	V
<b>&lt;Spindle block&gt;</b>						
<b>Hall bias</b>						
Hall bias voltage	$V_{HB}$	$V_{CC1} = 5\text{ V}$ , $I_{HB} = 20\text{ mA}$	0.7	1.2	1.6	V
<b>Hall amplifier</b>						
Input bias current	$I_{BH}$	$V_{CC1} = 5\text{ V}$	—	1	5	$\mu\text{A}$
In-phase input voltage range	$V_{HBR}$	$V_{CC1} = 5\text{ V}$	1.5	—	4.0	V
Minimum input level	$V_{INH}$	$V_{CC1} = 5\text{ V}$	60	—	—	mV[p-p]
<b>Torque command</b>						
In-phase input voltage range	EC	$V_{CC1} = 5\text{ V}$	0.5	—	3.9	V
Offset voltage	$EC_{OF}$	$V_{CC1} = 5\text{ V}$	-100	0	100	mV
Dead zone	$EC_{DZ}$	$V_{CC1} = 5\text{ V}$	25	75	125	mV
Input current	$EC_{IN}$	$V_{CC1} = 5\text{ V}$ , $EC = ECR = 1.65\text{ V}$	-5	-0.25	—	$\mu\text{A}$
Input/output gain	$A_{CS}$	$V_{CC1} = 5\text{ V}$ , $R_{CS} = 0.6\ \Omega$	0.75	1.0	1.25	A/V
<b>Output</b>						
High-level output saturation voltage	$V_{OH}$	$V_{CC1} = 5\text{ V}$ , $I_O = -300\text{ mA}$	—	0.9	1.6	V
Low-level output saturation voltage	$V_{OL}$	$V_{CC1} = 5\text{ V}$ , $I_O = 300\text{ mA}$	—	0.2	0.6	V
Torque limit current	$I_{TL}$	$V_{CC} = 5\text{ V}$ , $R_{CS} = 0.6\ \Omega$	400	500	600	mA

**■ Electrical Characteristics at  $T_a = 25^\circ\text{C}$  (continued)**

Parameter	Symbol	Conditions	Min	Typ	Max	Unit
<Spindle block> (continued)						
FG						
FG output high-level	$V_{GH}$	$V_{CC1} = 5\text{ V}$ , $I_{FG} = -0.01\text{ mA}$	3.0	—	$V_{CC1}$	V
FG output low-level	$V_{GL}$	$V_{CC1} = 5\text{ V}$ , $I_{FG} = 0.01\text{ mA}$	—	—	0.5	V
In-phase input voltage range	$V_{FGR}$	$V_{CC1} = 5\text{ V}$ , Input D-range at H2+, H2-	1.5	—	3.0	V
FG hysteresis width	$H_{FG}$	$V_{CC1} = 5\text{ V}$	1	10	20	mV
Brake circuit						
Short brake model level	$V_{SBR}$	$V_{CC1} = 5\text{ V}$	—	—	1.0	V
Reverse rotation brake mode level	$V_{RBR}$	$V_{CC1} = 5\text{ V}$	3.5	—	—	V
Short brake start level	$V_{SBRL}$	$V_{CC1} = 5\text{ V}$ , $ECR = 1.65\text{ V}$	1.65	1.74	—	V
Short brake current	$I_{SBR}$	$V_{CC1} = 5\text{ V}$	60	90	—	mA
<Driver block>						
Driver $R_L = 16\ \Omega$						
Output offset voltage	$V_{DROF}$	SL IN = 1.65 V	-150	0	+150	mV
+ gain	$G_{SL+}$	R IN = 10 k $\Omega$	21	23	25	dB
+/- relative gain	$G_{SL}$		-0.7	0	+0.7	dB
Output D range '+'	$V_{O+}$	SL IN = 3.3 V	9.3	10.0	—	V
Output D range '-'	$V_{O-}$	SL IN = 0 V	—	-10.0	-9.3	V
Power cut operation						
High-level PC threshold voltage	$V_{PCH}$	$V_{CC2} = 12\text{ V}$	2.9	—	—	V
Low-level PC threshold voltage	$V_{PCL}$	$V_{CC2} = 12\text{ V}$	—	—	1.0	V
PC input current	$I_{PC}$	$V_{CC2} = 12\text{ V}$ , PC = 5 V	—	100	200	$\mu\text{A}$
Reset circuit						
Reset operation release supply voltage	$V_{RST}$		—	—	4.5	V
$V_{REF}$ detection voltage	$V_R$		1.35	—	—	

**• Design reference data**

Note) The characteristics listed below are theoretical values based on the IC design and are not guaranteed.

Parameter	Symbol	Conditions	Min	Typ	Max	Unit
Thermal protection						
Thermal protection operating temperature	$T_{SDON}$	$V_{CC1} = 5\text{ V}$	—	160	—	$^\circ\text{C}$
Thermal protection hysteresis width	$\Delta T_{SD}$	$V_{CC1} = 5\text{ V}$	—	45	—	$^\circ\text{C}$
Sled block supply voltage						
Sled block supply voltage detection hysteresis width	$\Delta V_{HD}$		—	0.2	—	V

■ Usage Notes

1. Use the  $V_{CC2}$  at  $V_{CC2} \geq V_{M2}$ . And use power supply always at on state. Otherwise it will cause malfunction.
2. On driver gain setting of driver block.

Voltage gain of power amplifier: 23 dB

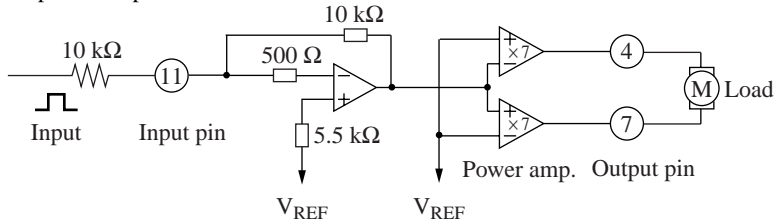

3. On operation mode of mute:

	PC	
	H	L (Open)
Driver output	Active	Mute

4. On SS pin mode:

	SS		
	H	M	L (Open)
Spindle block	On	Off	Off
Driver block	On	On	Off

5. On brake mode of spindle block:

	BRK	
	H	L (Open)
EC < ECR	Acceleration	Acceleration
EC > ECR	Reverse rotation brake	Short brake

6. Take time to check the characteristics on use.

When changing an external circuit constant for use, consider not only static characteristics, but also transient characteristics and external parts with respect to the characteristics difference among ICs so that you can get enough margin.

7. Avoid short-circuit between output pin and power supply, output pin and GND (line-to-supply and line-to-ground fault) and output pins (load short-circuit). Otherwise the IC will be damaged and is likely to get fired.
8. Be cautious on a dip soldering. Prior study is required.

■ Application Notes

- $P_D - T_a$  curves of HSOP042-P-0400

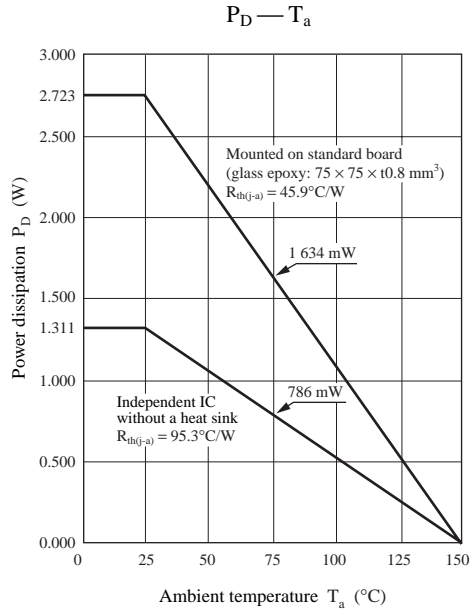

- Phase conditions between Hall input and output current

	Phase of Hall pin		
	H1+	H2+	H3+
A	H	M	L
B	H	L	M
C	M	L	H
D	L	M	H
E	L	H	M
F	M	H	L

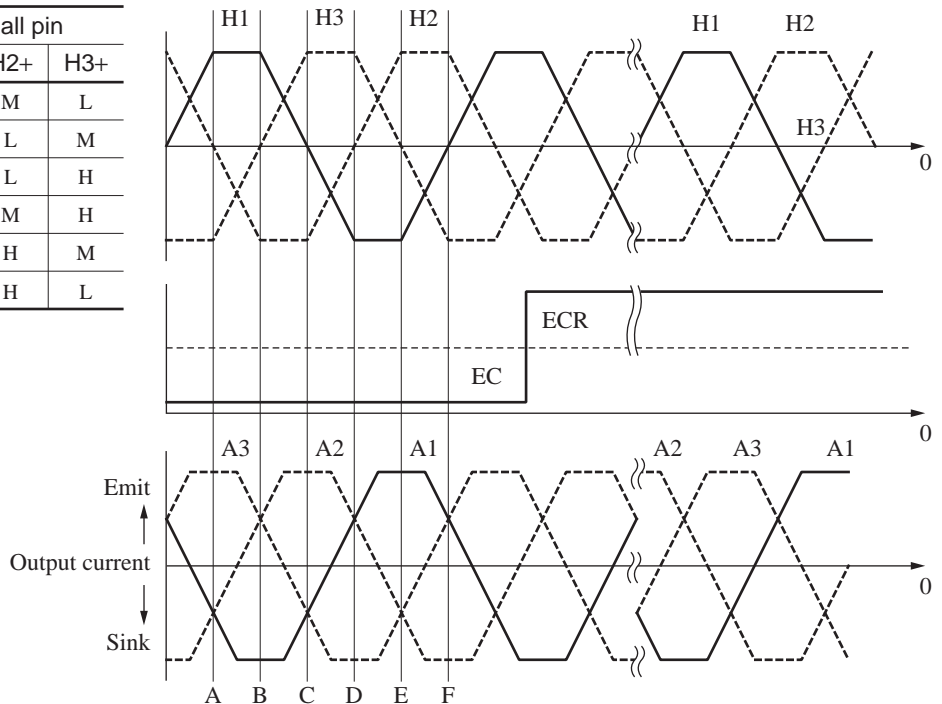

■ Application Notes (continued)

• Power consumption calculation method

You can find a rough value of electric power to be consumed in the IC in the following method and the use of EXCEL (computer soft ware) will enable you to put it on a graph.

Calculating formula:

(Spindle block)

1. Let an induced voltage generated in each phase as below:

(Reference to a motor center point)

$$E_{A1} = E_O \times \sin(X) \cdots (1) \quad E_{A2} = E_O \times \sin(X+120) \cdots (2)$$

$$E_{A3} = E_O \times \sin(X+240) \cdots (3) \quad X: \text{Phase angle}$$

2. Let a current flowing in each phase as below:

$$I_{A1} = I_O \times \sin(X) \cdots (4) \quad I_{A2} = I_O \times \sin(X+120) \cdots (5)$$

$$I_{A3} = I_O \times \sin(X+240) \cdots (6)$$

3. The voltages generated by a wire-wound resistance of a motor are:

$$V_{R1} = I_{A1} \times R \cdots (7) \quad V_{R2} = I_{A2} \times R \cdots (8) \quad V_{R3} = I_{A3} \times R \cdots (9)$$

4. In each phase, add the voltage generated by an induced voltage and that by a wire-wound resistance.

$$V_{A1}' = (1) + (4) \quad V_{A2}' = (2) + (5) \quad V_{A3}' = (3) + (6)$$

5. As the lowest voltage in each phase angle must be 0 V, you can get the voltage to be generated in each phase by means of subtracting the lowest voltage from the voltage of the remaining two phases.

$$V_{A1} = V_{A1}' - \text{MIN}(V_{A1}', V_{A2}', V_{A3}') \cdots (10)$$

$$V_{A2} = V_{A2}' - \text{MIN}(V_{A1}', V_{A2}', V_{A3}') \cdots (11)$$

$$V_{A3} = V_{A3}' - \text{MIN}(V_{A1}', V_{A2}', V_{A3}') \cdots (12)$$

6. Subtract the supply voltage from each phase's voltage found in item 5 and then multiply it by each phase's current, so that you can get the power consumption of the spindle block.

$$P_{SPD} = \sum_{n=1}^3 (12 - V_{An}) \times I_{An}$$

(Driver block)

$$P_{SL} = (V_{M2} - I_O \cdot R) \times I_O$$

$V_{M2}$ : Motor power supply voltage       $I_O$ : Output current      R: Wire wound resistor

• Theory of thermal resistance

A chip temperature or the fin temperature can be understood in the same way as Ohm's Law.

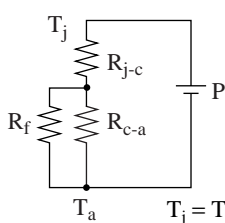

$T_j$  : Chip temperature

$T_a$  : Ambient temperature

P : Electric power generated by IC

$R_{j-c}$  : Thermal resistance between a chip and a package

$R_{c-a}$  : Thermal resistance between a package and a surface of a heat sink or free air

Make sure that  $T_j$  does not exceed 150°C.

If it exceeds 150°C, you can suppress the rise of a chip temperature by adding a heat sink which is equivalent to  $R_f$  in the above figure.

$$T_j = T_a + P \times (R_{j-c} + R_{c-a})$$

A package surface and the fin are available for a temperature measurement. But the fin part is recommendable for measurement because a package surface measurement does not always promise you a consistent measuring result.

Note) What has been mentioned above is true to a stationary state, not to a transient state.

■ Application Circuit Example

