

AN8612NSB

SCSI active terminator IC

Overview

The AN8612NSB is a terminator IC conformed to standard interface specification (SCSI-I/II) for personal computers, workstations and various types of information equipment. So far configured with a fixed resistor and a regulator, it has recently been integrated onto a single chip with built-in standby function.

It is easy to satisfy 25 pF of the maximum pin capacitance in SCSI-II specification due to its small output pin capacitance. It can support 10 Mbyte/s of SCSI-II and 20 Mbyte/s of FAST-20.

Features

- Active termination for 18-signal line
- Low power consumption due to its standby function (100 μ A at standby).
- Small output pin capacitance: 3.8 pF (typ.)
- High precision regulator: 2.85 V \pm 60 mV

Applications

- SCSI interface board of PC
- SCSI-compatible equipment such as CD-ROM, MO, PD, MD drive and printer

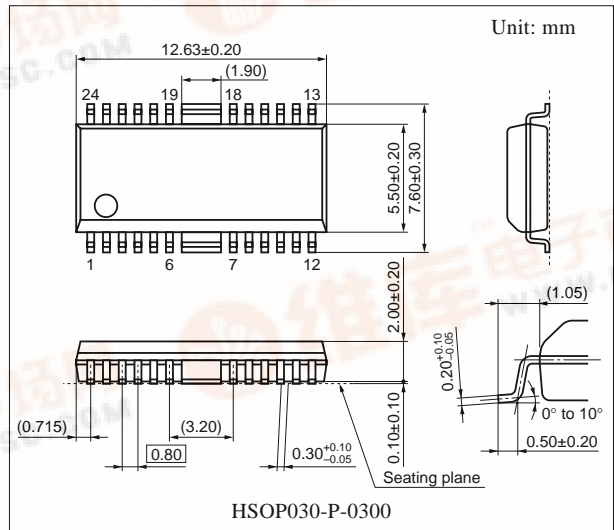

■ Block Diagram

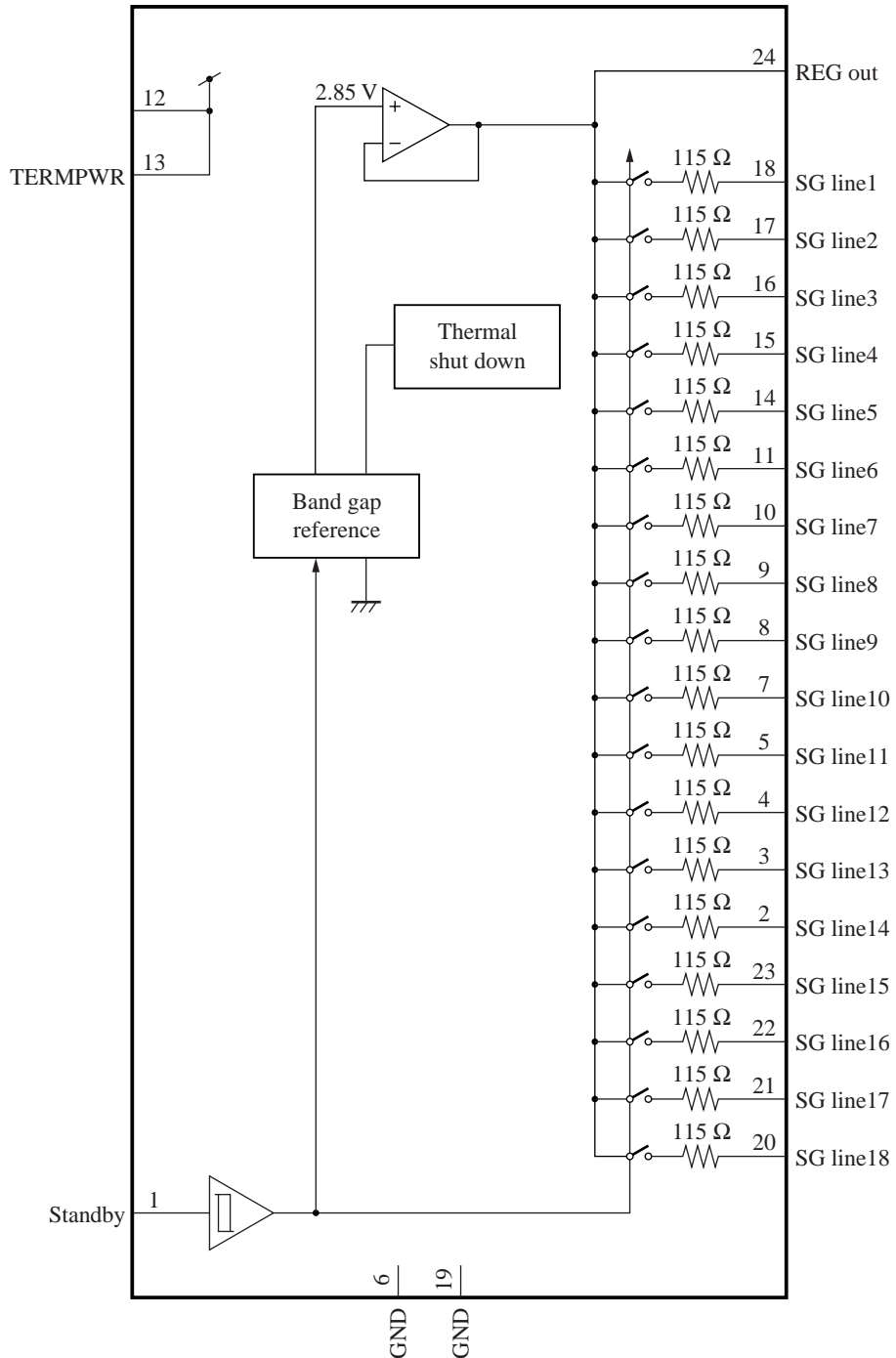

■ Pin Descriptions

Pin No.	Description	Pin No.	Description
1	Standby *1	13	V _{CC} (TERMPWR) *3
2	SG line14	14	SG line5
3	SG line13	15	SG line4
4	SG line12	16	SG line3
5	SG line11	17	SG line2
6	GND *2	18	SG line1
Fin	GND *2	Fin	GND *2
7	SG line10	19	GND *2
8	SG line9	20	SG line18
9	SG line8	21	SG line17
10	SG line7	22	SG line16
11	SG line6	23	SG line15
12	V _{CC} (TERMPWR) *3	24	REG out

Note) *1: A standby pin input voltage becomes an active mode at $V_I < V_{TH}$ and a standby mode at $V_I > V_{TH+}$.

Likewise, a standby mode when standby pin is open.

*2: Both ground pins of the pin 6 and pin 19 should be placed on the same pattern, and the pattern should be wide on the PCB.
(We recommend that whole surface of one layer of a multi-layer PCB be GND.)

*3: Connect the V_{CC} to SCSI termination resistor power supply (TERMPWR).

■ Absolute Maximum Ratings

Parameter	Symbol	Rating	Unit
Supply voltage	V _{CC}	6.0	V
Supply current	I _{CC}	550	mA
Power dissipation *2	P _D	412	mW
Operating ambient temperature *1	T _{opr}	-20 to +75	°C
Storage temperature *1	T _{stg}	-55 to +150	°C

Note) *1: Except for the power dissipation, operating ambient temperature and storage temperature, all ratings are for T_a = 25°C.

*2: T_a = 75°C. For the independent IC without a heat sink.

Refer to "■ Application Notes".

■ Recommended Operating Range

Parameter	Symbol	Range	Unit
Supply voltage	V _{CC}	4.0 to 5.5	V

■ Electrical Characteristics at $V_{CC} = 5.0\text{ V}$, $T_a = 25^\circ\text{C}$

Parameter	Symbol	Conditions	Min	Typ	Max	Unit
Supply current 1	I_{CC1}	Standby = low, all SG line = open	—	44	54	mA
Supply current 2	I_{CC2}	Standby = low, All SG line = 0.2 V	—	458	530	mA
Supply current 3	I_{CC3}	Standby = open	—	100	200	μA
Standby pin low-level input current	I_{STBYL}	$V_{CC} = 5.5\text{ V}$, $V_I = 0\text{ V}$	-150	-50	—	μA
Standby pin high-level input current	I_{STBYH}	$V_{CC} = 5.5\text{ V}$, $V_I = 5.5\text{ V}$	—	—	1	μA
Standby pin positive direction threshold voltage	V_{TH+}		1.3	1.5	1.7	V
Standby pin negative direction threshold voltage	V_{TH-}		1.1	1.3	1.5	V
Maximum output current SG line1 to SG line18	I_{SG}	$V_{SG} = 0.2\text{ V}$	19.8	23.0	26.2	mA
Output leak current 1 SG line1 to SG line18	I_{LK1}	$V_{CC} = 5.5\text{ V}$ Standby = open, $V_{SG} = 0\text{ V}$	-1	—	—	μA
Output leak current 2 SG line1 to SG line18	I_{LK2}	$V_{CC} = 5.5\text{ V}$, $V_{SG} = 2.85\text{ V}$ Standby = open	-1	—	1	μA
REG output voltage 1	V_{REG1}	$V_{CC} = 4.0\text{ V}$ to 5.5 V , all SG line = open	2.79	2.85	2.91	V
REG output voltage 2	V_{REG2}	$V_{CC} = 3.2\text{ V}$, all SG line = open	2.00	—	—	V
Termination resistance value SG line1 to SG line18	R_{SG}	$I_{SG} = 5\text{ mA}$ to 15 mA	107	115	123	Ω
High-level output voltage SG line1 to SG line18	V_{SGH}	$V_{CC} = 4.0\text{ V}$ to 5.5 V , all SG line = open	2.78	2.85	2.92	V

• Design reference data

Note) The characteristics listed below are theoretical values based on the IC design and are not guaranteed.

Parameter	Symbol	Conditions	Min	Typ	Max	Unit
Standby pin hysteresis width	V_{HYS}		—	200	—	mV
Output pin capacitance	C_{SG}		—	3.8	4.5	pF
Thermal shutdown temperature	T_{TSD}		—	170	—	$^\circ\text{C}$

■ Terminal Equivalent Circuits

Pin No.	Symbol	Equivalent circuit
1	Standby	

■ Terminal Equivalent Circuits (continued)

Pin No.	Symbol	Equivalent circuit
2 3 4 5	Pin 2: SG line14 Pin 3: SG line13 Pin 4: SG line12 Pin 5: SG line11	
6	GND	—
Fin	GND	—
7 8 9 10 11	Pin 7: SG line10 Pin 8: SG line9 Pin 9: SG line8 Pin 10: SG line7 Pin 11: SG line6	
12 13	Pin 12: V _{CC} (TERMPWR) Pin 13: V _{CC} (TERMPWR)	
14 15 16 17 18	Pin 14: SG line5 Pin 15: SG line4 Pin 16: SG line3 Pin 17: SG line2 Pin 18: SG line1	

■ Terminal Equivalent Circuits (continued)

Pin No.	Symbol	Equivalent circuit
Fin	GND	—
19	GND	—
20 21 22 23	Pin 20: SG line18 Pin 21: SG line17 Pin 22: SG line16 Pin 23: SG line15	
24	REG out	

■ Application Notes

- $P_D - T_a$ curves of HSOP030-P-0300

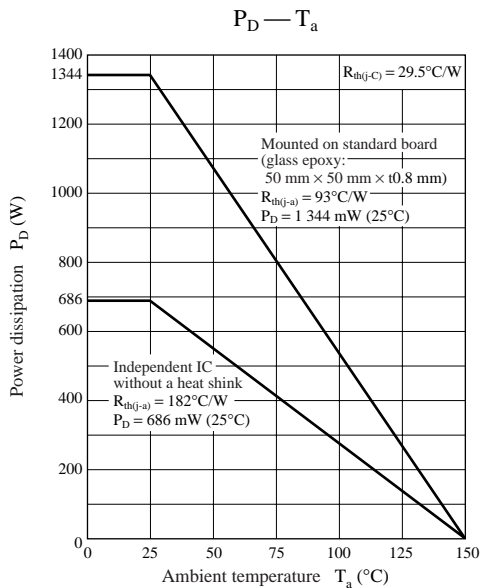

■ Application Circuit Example

