

AN8746SA

PWM driver IC for portable CD player

Overview

The AN8746SA is a 4-channel actuator/motor drive IC by DMOS direct PWM method for a portable CD player.

Features

- $R_{ON} = 1.8 \Omega$ (typ.)
- Supply voltage range
(Control block: 2.0 V to 3.6 V, power block: 1.2 V to 3.6 V)
- Current at standby
(Control block: 1 μ A or less, power block: 1 μ A or less)
- With an output pin of monitoring 1/2 of the power supply voltage

Applications

- Portable CD player

Block Diagram

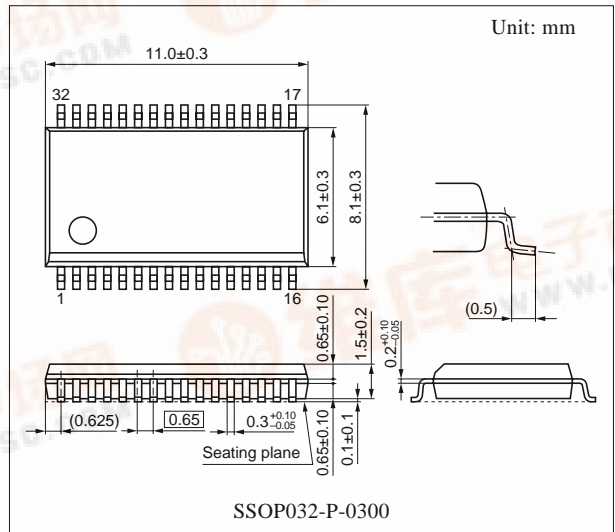
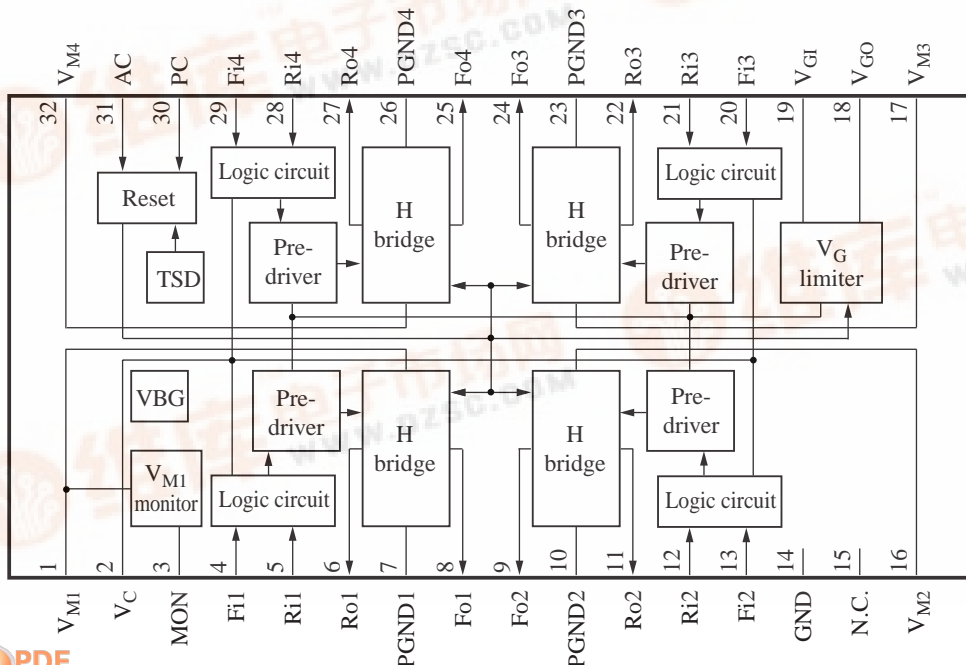

■ Pin Descriptions

Pin No.	Symbol	Description	Pin No.	Symbol	Description
1	V _{M1}	Ch. 1 power supply	17	V _{M3}	Ch.3 power supply
2	V _C	Control circuit power supply	18	V _{GO}	Gate voltage clamp output
3	MON	VM1 monitor	19	V _{GI}	Gate voltage input pin
4	Fil	Ch. 1 forward direction input pin	20	Fi3	Ch. 3 forward direction input pin
5	Ril	Ch. 1 reverse direction input pin	21	Ri3	Ch. 3 reverse direction input pin
6	Ro1	Ch. 1 reverse direction output pin	22	Ro3	Ch. 3 reverse direction output pin
7	PGND1	Ch. 1 power ground	23	PGND3	Ch. 3 power ground
8	Fo1	Ch. 1 forward direction output pin	24	Fo3	Ch. 3 forward direction output pin
9	Fo2	Ch. 2 forward direction output pin	25	Fo4	Ch. 4 forward direction output pin
10	PGND2	Ch. 2 power ground	26	PGND4	Ch. 4 power ground
11	Ro2	Ch. 2 reverse direction output pin	27	Ro4	Ch. 4 reverse direction output pin
12	Ri2	Ch. 2 reverse direction input pin	28	Ri4	Ch. 4 reverse direction input pin
13	Fi2	Ch. 2 forward direction input pin	29	Fi4	Ch. 4 forward direction input pin
14	GND	Control circuit ground	30	PC	Power cut pin
15	N.C.	—	31	AC	All cut-off pin
16	V _{M2}	Ch. 2 power supply	32	V _{M4}	Ch. 4 power supply

■ Absolute Maximum Ratings

Parameter	Symbol	Rating	Unit
Supply voltage	V _C	5	V
	V _M	7	
	V _{GI}	8.2	
Supply current	I _{DD}	500	mA
Power dissipation *2	P _D	400	mW
Operating ambient temperature *1	T _{opr}	-30 to +75	°C
Storage temperature *1	T _{stg}	-55 to +150	°C

Note) *1: Except for the operating ambient temperature and storage temperature, all ratings are for T_a = 25°C.

*2: Use within the range of P_D = 390 mW or less at T_a = 75°C, following the allowable power dissipation characteristic curve of "■ Application Notes".

■ Recommended Operating Range

Parameter	Symbol	Range	Unit
Supply voltage	V _C	2.0 to 2.4 to 3.6	V
	V _M	1.2 to 2.4 to 3.6	
	V _{GI}	V _M +3.5 to 7.0 to 8.0	
Signal input voltage	V _{IN}	0 to V _C	V

■ Electrical Characteristics at $V_C = 2.4\text{ V}$, $V_{M12} = V_{M34} = 2.4\text{ V}$, $V_{GI} = 7.0\text{ V}$, $AC = PC = 2.4\text{ V}$, $R_L = 8\ \Omega$, $T_a = 25^\circ\text{C}$

Parameter	Symbol	Conditions	Min	Typ	Max	Unit
Power supply current at mute (at $PC = L$ or $V_C = L$) *1	I_{MO}	$PC = 0\text{ V}$, $AC = V_C = 2.4\text{ V}$ or $V_C = PC = AC = 0\text{ V}$	—	—	1	μA
Control supply current at all cut (at $AC = L$ or $PC = L$)	I_{CO}	$AC = L$, $PC = L$	—	—	1	μA
Control supply current at operating *2	I_C	$AC = PC = V_C = 2.4\text{ V}$	—	0.5	1	mA
Pre-driver supply current at all cut (at $AC = L$) *2	I_{GO}	$AC = 0\text{ V}$	—	—	1	μA
Pre-driver supply current at operation (at $V_{GI} = 7\text{ V}$) *2	I_G	$AC = PC = V_C = 2.4\text{ V}$	—	0.5	1	mA
PWM input voltage high-level	V_{INH}	$AC = PC = V_C = 2.4\text{ V}$ Fil to Fi4 = Ril to Ri4 = H	$V_C - 0.6$	—	—	V
PWM input voltage low-level	V_{INL}	$AC = PC = V_C = 2.4\text{ V}$ Fil to Fi4 = Ril to Ri4 = L	—	—	0.6	V
PWM input current high-level	I_{INH}	$AC = PC = V_C = 2.4\text{ V}$ Fil to Fi4 = Ril to Ri4 = H	—	—	1	μA
PWM input current low-level	I_{INL}	$AC = PC = V_C = 2.4\text{ V}$ Fil to Fi4 = Ril to Ri4 = L	-1	—	—	μA
Driver on resistance (upper and lower)	R_{ON}	$AC = PC = V_C = 2.4\text{ V}$	—	1.8	2.5	Ω
Output propagation delay time at rising *2	t_{Dr}	$AC = PC = V_C = 2.4\text{ V}$	—	0.2	1	μs
Output propagation delay time at falling *2	t_{Df}	$AC = PC = V_C = 2.4\text{ V}$	—	0.2	1	μs
Output propagation delay time difference $t_{Dr} - t_{Df}$	Δt_D	$AC = PC = V_C = 2.4\text{ V}$	-0.3	—	0.3	μs
Minimum input pulse width *3	t_{min}	$AC = PC = V_C = 2.4\text{ V}$	0.3	—	—	μs
V_M monitor output voltage width	V_{MON}	$AC = PC = V_C = 2.4\text{ V}$	1.1	1.2	1.3	V
V_M monitor output gain	G_{MON}	$AC = PC = V_C = 2.4\text{ V}$	0.45	0.5	0.55	—
Power output pin flow-out/in current at low V_C *1	I_{HZ}	$AC = PC = V_C = 0\text{ V}$	-50	—	50	μA
V_M monitor output voltage at V_C limit	$LMON$	$V_{M12} = V_{M34} = 5.0\text{ V}$ $AC = PC = V_C = 1.9\text{ V}$	1.7	1.9	2.1	V

Note) *1: AC pin and PC pin are connected to V_C pin via a protective diode.

AC pin and PC pin must be set to 0 V at $V_C = 0\text{ V}$ to avoid excessive flow-in current.

*2: Measure at $f = 44.1\text{ kHz}$ and in duty ratio = 50%.

*3: Measure at $f = 44.1\text{ kHz}$. Output pulse width must be $\geq t_{min} / 2$.

■ Electrical Characteristics at $V_C = 2.4\text{ V}$, $V_{M12} = V_{M34} = 2.4\text{ V}$, $V_{GI} = 7.0\text{ V}$, $AC = PC = 2.4\text{ V}$, $R_L = 8\ \Omega$, $T_a = 25^\circ\text{C}$ (continued)

• Design reference data

Note) The characteristics listed below are theoretical values based on the IC design and are not guaranteed.

Parameter	Symbol	Conditions	Min	Typ	Max	Unit
Thermal protection						
Thermal protection operating temperature	T_{THD}		—	145	—	$^\circ\text{C}$
Thermal protection hysteresis width	ΔT_{THD}		—	20	—	$^\circ\text{C}$

■ Usage Notes

1. Care should be taken so as not to cause any of the following conditions on use of this IC. If the following conditions come up, the IC is likely to break down or to be smoking.

Short-circuit between output pins

Short-circuit between output pin and GND

Short-circuit between output pin and power supply

(Output pin refers to any of those Fo1 (pin 8), Ro1 (pin 6), Fo2 (pin 9), Ro2 (pin 11), Fo3 (pin 24), Ro3 (pin 22), Fo4 (pin 25), Ro4 (pin 27). GND refers to any of those GND (pin 14), PGND1 (pin 7), PGND2 (pin 10), PGND3 (pin 23), PGND4 (pin 26). Power supply refers to any of those V_C (pin 2), V_{GI} (pin 19), V_{M1} (pin 1), V_{M2} (pin 16), V_{M3} (pin 17), V_{M4} (pin 32).

2. V_{M1} monitor pin (pin 3) outputs approximately one half of V_{M1} voltage and its upper limit is V_C supply voltage. This is meant to prevent the DSP connected to this Pin from damage when the voltage exceeding an operating supply voltage range is inputted to the V_{M1} pin. On use of this pin, therefore, note that no value exceeding V_C is outputted.

■ Application Notes

1. $P_D - T_a$ curves of SSOP032-P-0300

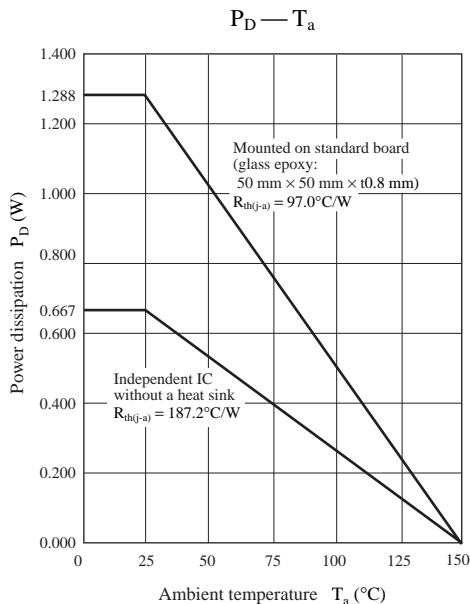

■ Application Notes

2. Logic table of driver

V _C	PC	Fil to Fi4	Ril to Ri4	Fol to Fo3	Rol to Ro3	Fo4	Ro4
H	H	L	L	L	L	L	L
H	H	L	H	L	H	L	H
H	H	H	L	H	L	L	L
H	H	H	H	L	L	H	L
H	L	X	X	L	L	L	L
L	X	X	X	Hi-Z	Hi-Z	Hi-Z	Hi-Z

Note) AC = H on the above logic table. H stands for V_C power supply potential, L for GND potential (0 V) and X for H or L.

Hi-Z indicates that the driver output pin becomes a high impedance state.

Logic input pin must not be left open. And do not apply any other voltages than H or L.

■ Application Circuit Example

